

81142

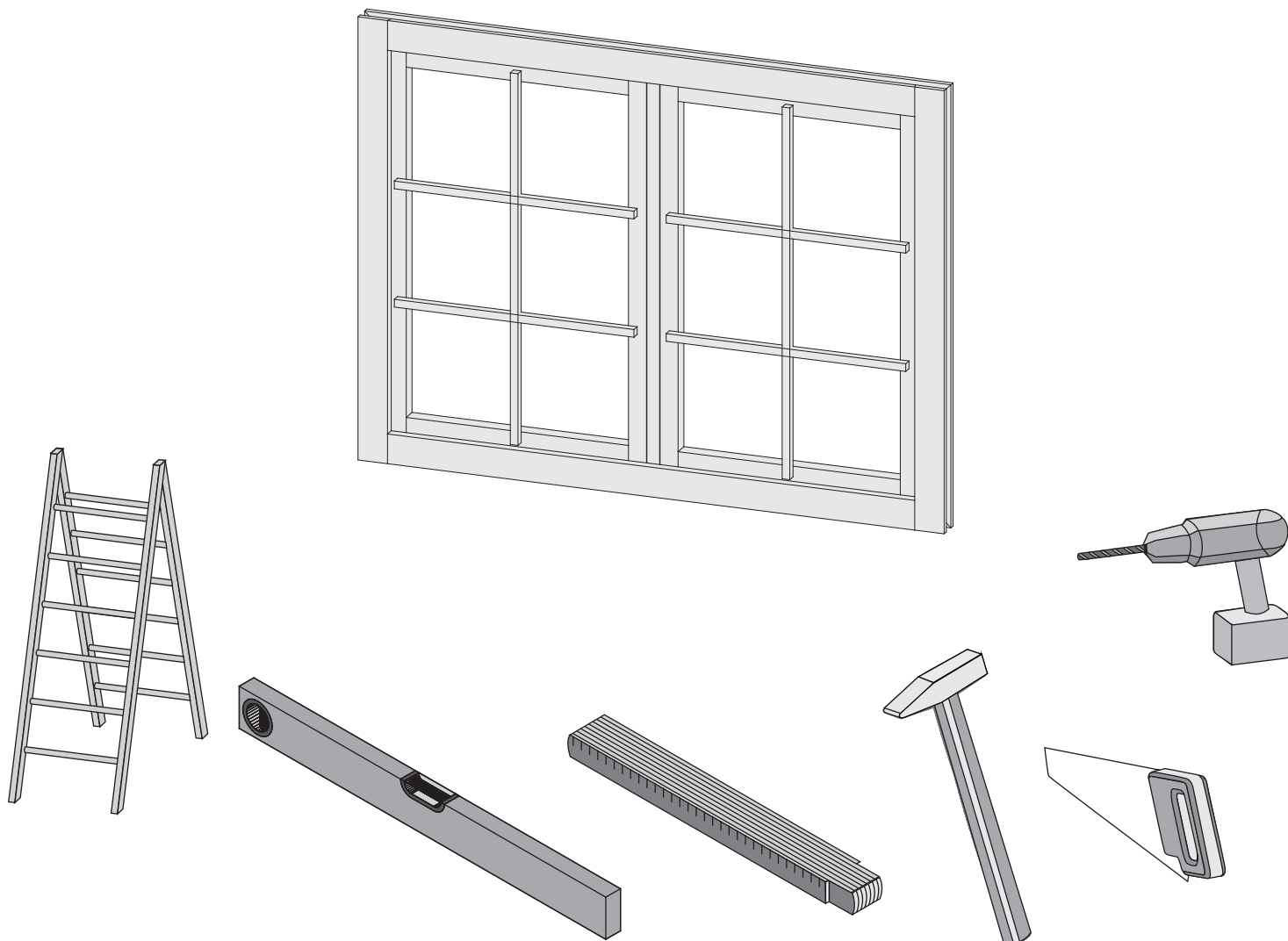

Aufbauanleitung



notice de montage



Building Instructions



montagehandleiding



Instrucciones de construcción



Istruzioni per il montaggio



Montážní návod



Service-Hotline: +49 421 38693 33



Vergleichen Sie zuerst die Materialliste mit Ihrem Paketinhalt! Bitte haben Sie Verständnis, dass Beanstandungen nur im nicht aufgebauten Zustand bearbeitet werden können!



En primer lugar, compare la lista de material con el contenido del paquete. Rogamos entienda que las reclamaciones sólo pueden ser tramitadas antes de montar el objeto!



Nejprve přkontrolujte obsah balení podle materiálového listu! Mějte pochopení pro to, že případnou reklamaci se můžeme zabývat pouze tehdy, když díly nebudou smontované! Za pomoci tohoto seznamu můžete jednotlivé díly přiřadit k montážnímu návodu.



Vergelijk eerst de lijst van materialen met de inhoud van uw pakket! Reclamaties kunnen alleen in behandeling worden genomen zolang de onderdelen nog niet zijn gemonteerd!



First compare the list of materials with your package contents! Please understand that complaints can be processed in the non-built status only!



Commencez par comparer la liste du matériel avec le contenu de votre paquet! Sachez que nous traitons uniquement les réclamations concernant le matériel à l'état non monté!



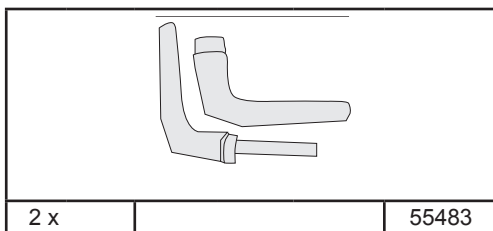
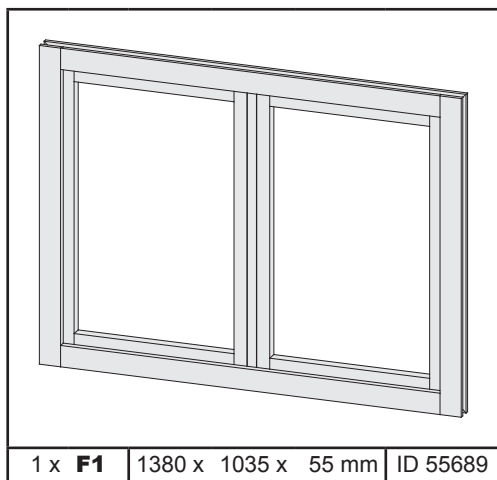
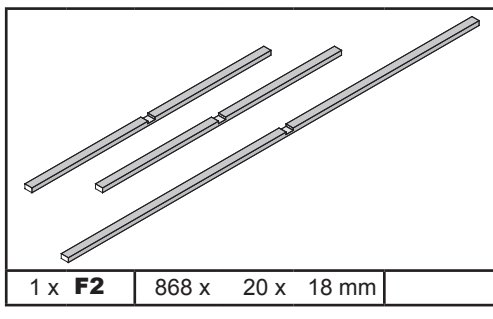
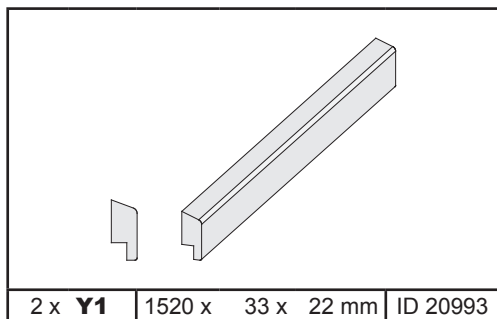
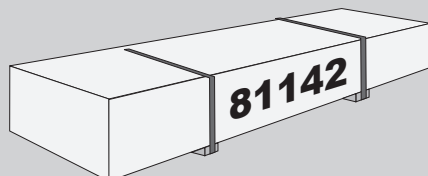

Confrontate questa distinta materiali prima con il contenuto del pacchetto! Vi preghiamo di comprendere che eventuali reclami possono essere accolti solo prima del montaggio!



*

 Nicht im Lieferumfang enthalten

 Niet bijgeleverd



 Not included



 Non comprises dans la livraison

 No forman parte del suministro

 Non incluso

 V ceně není zahrnuto

 Einbau Fenster
 Montage fenêtre
 Installation of window

 Montage van de raam
 Montaje de la ventana
 Installazione finestra

 instalační okno



01

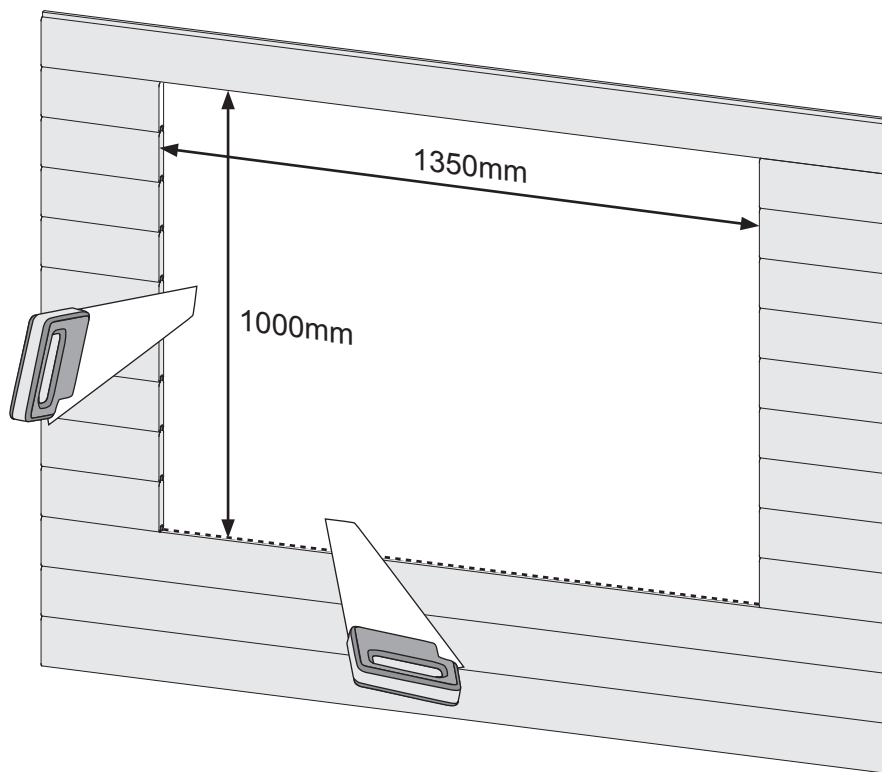

 Position frei wählbar
 Position librement sélectionnable
 Position freely selectable
 Positie vrij te kiezen
 Posición libremente seleccionable
 Posizione liberamente selezionabile
 Pozice volně volitelné

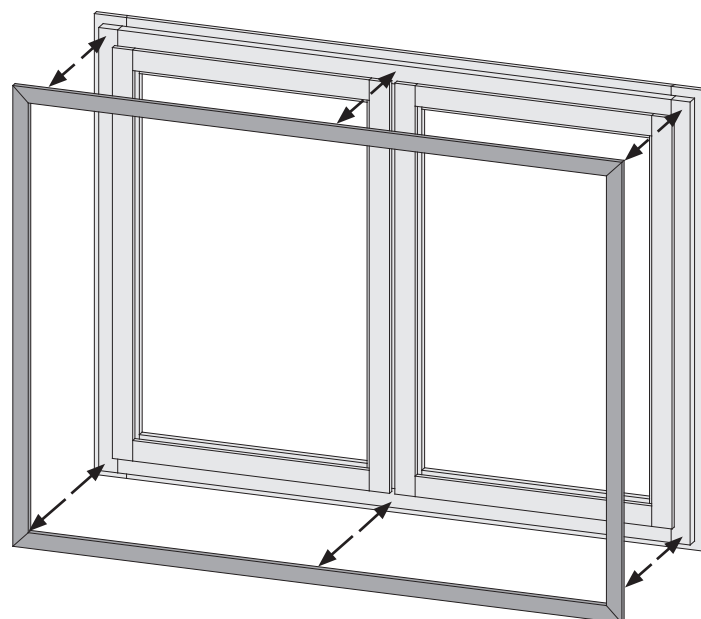
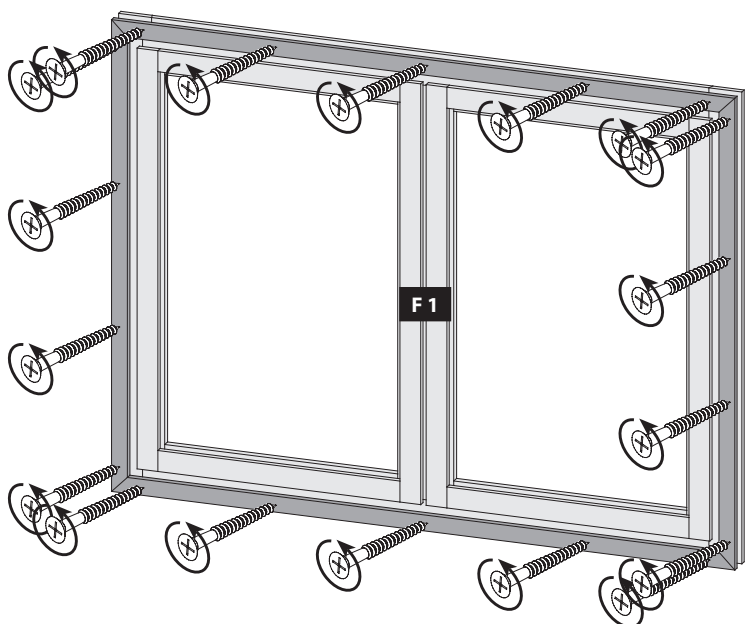

02



 Einbau Fenster
 Montage fenêtre
 Installation of window

 Montage van de raam
 Montaje de la ventana
 Installazione finestra

 instalační okno

03

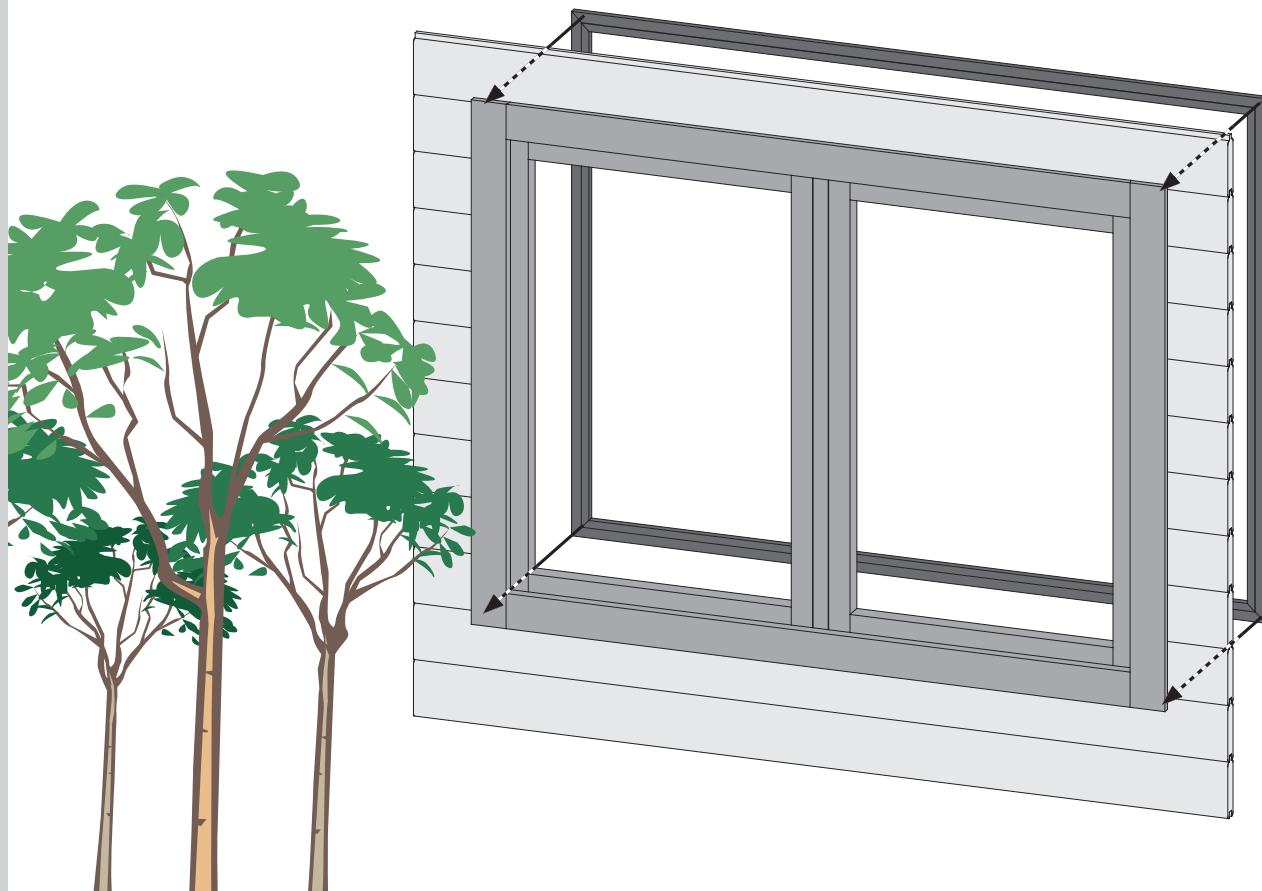

04

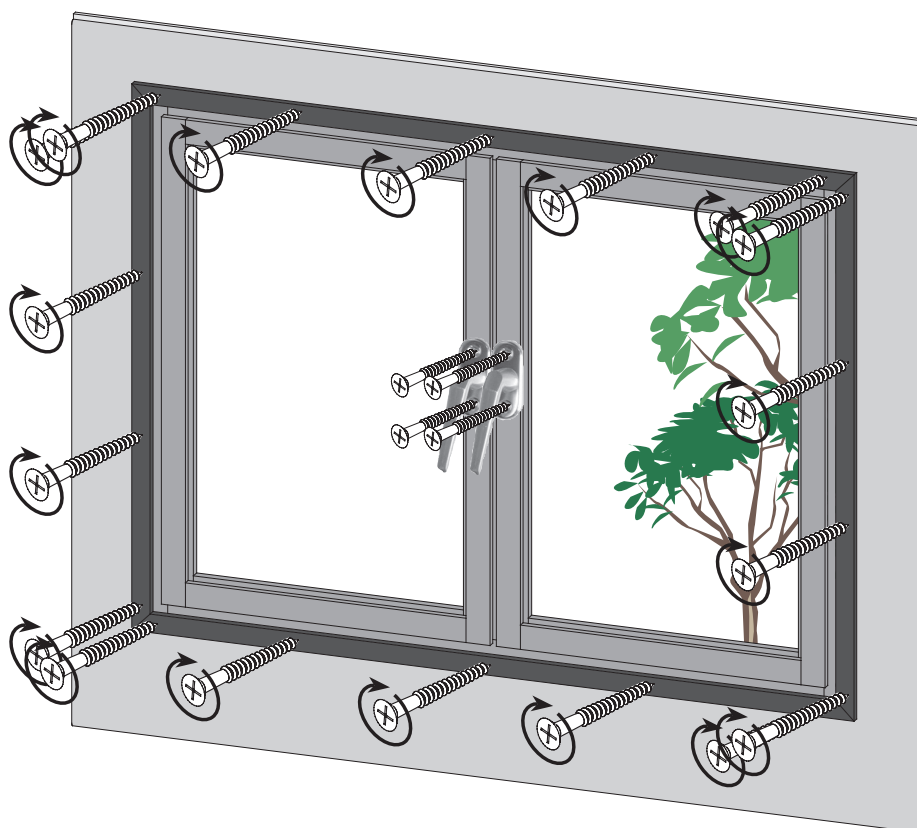



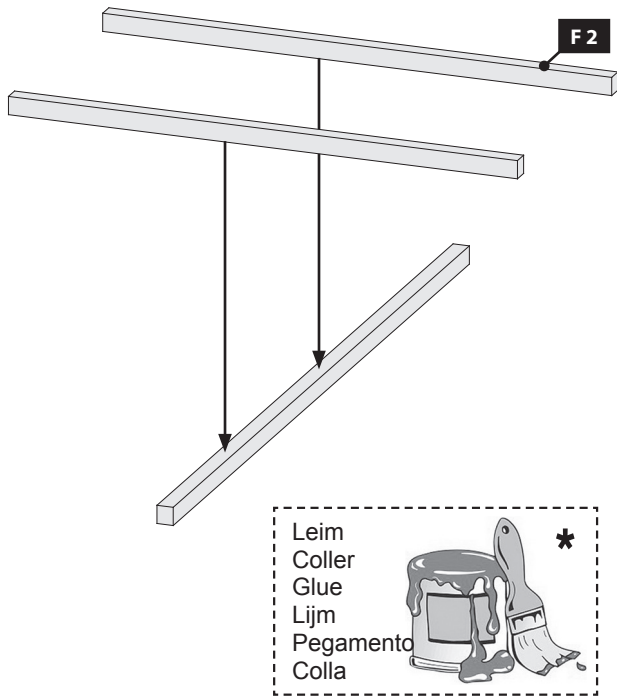

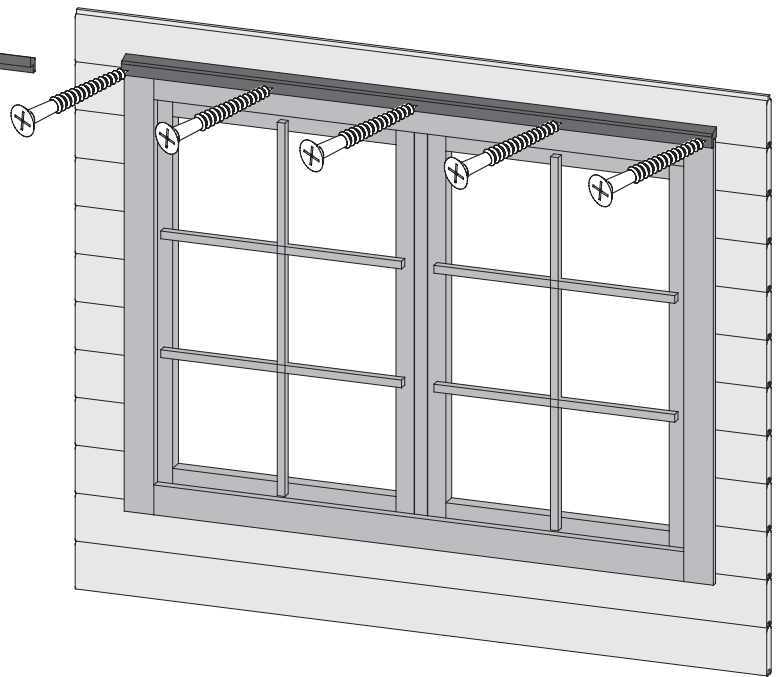
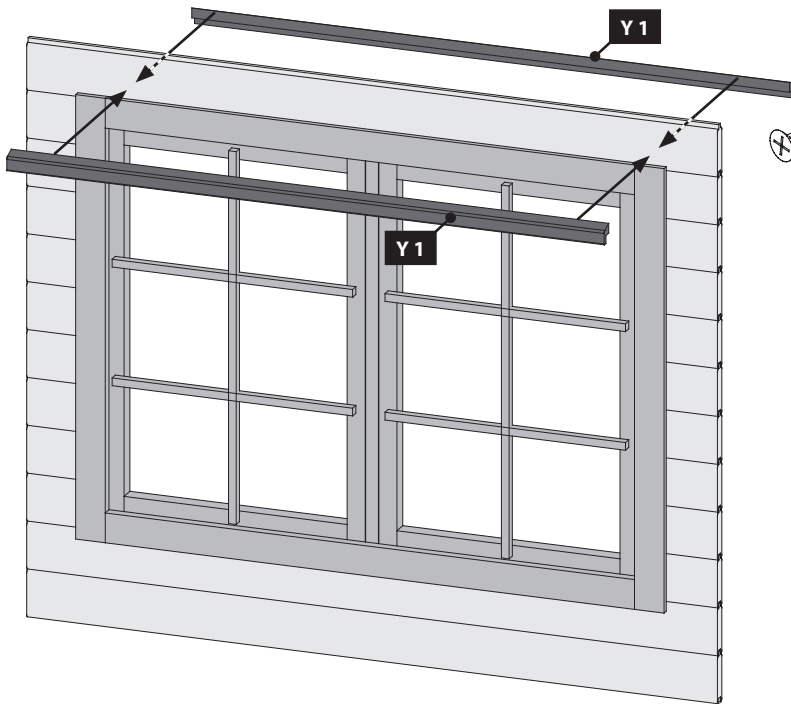
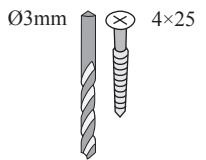

05 2x



06



-  Die Abdeckprofile dürfen nur mit dem Fenster und nicht mit dem Haus verschraubt werden!
-  De afdekprofielen mogen uitsluitend op het raam, niet op het huisje worden vastgeschroefd!
-  Les profils de panne sont à visser à la fenêtre, non à la maison!
-  Screw the capping profiles onto the window only, not onto the cabin!
-  Los perfiles de sombrerete sólo se pueden atornillar a la ventana, no a la caseta!
-  I cappellotti possono essere avvitati solo alla finestra, non alla casa!
-  Klobouk profily pouze s oknem a nebudou přišroubován k domu!

Y 1