

# 85031

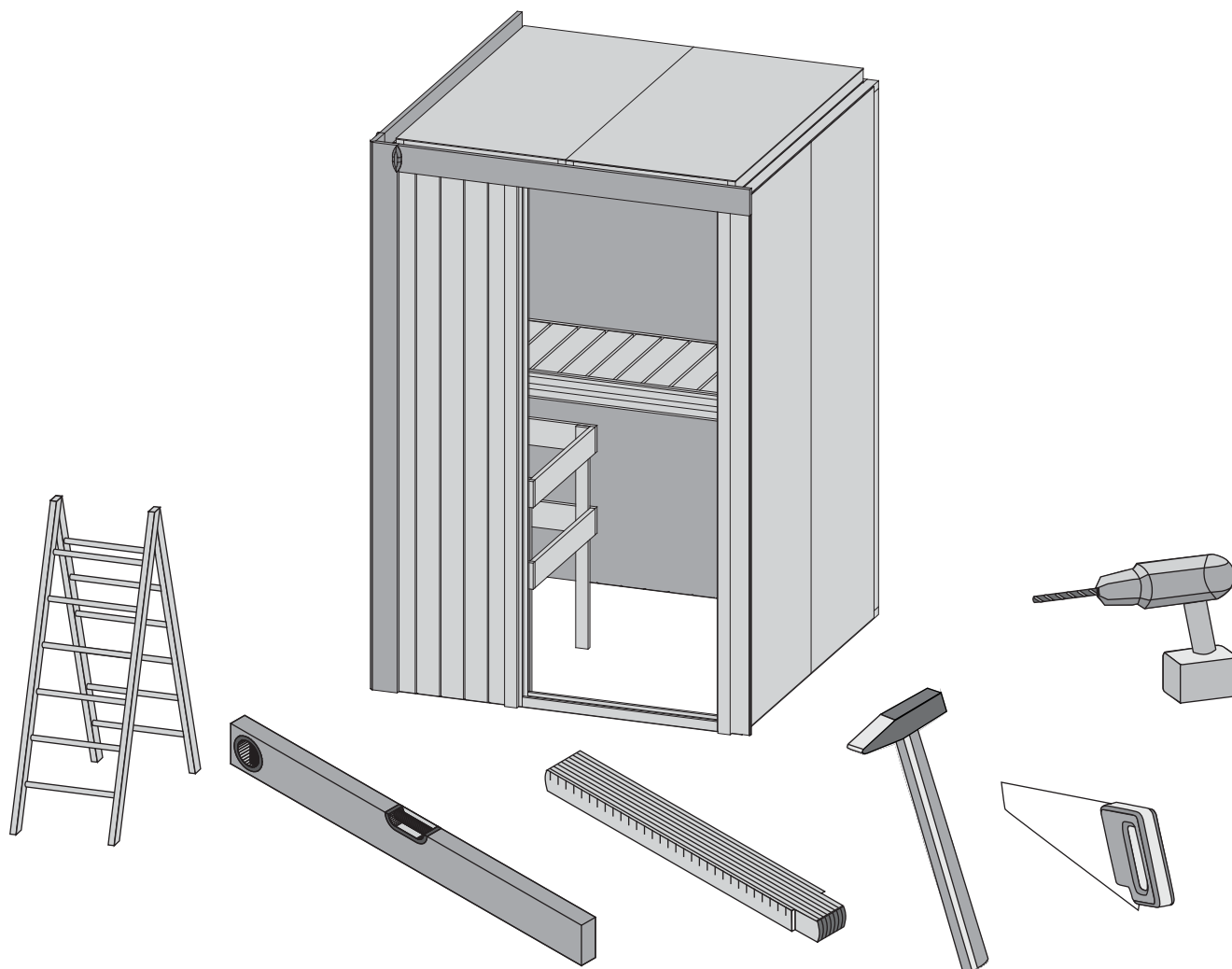

 **Aufbauanleitung**

 **Building Instructions**

 **notice de montage**

 **montagehandleiding**

 **Montagevejledning**

 **Instrucciones de construcción**

 **Istruzioni per il montaggio**

 **Montážní návod**



**+49 421 38693 33**



Vergleichen Sie zuerst die Material-liste mit Ihrem Paketinhalt! Bitte haben Sie Verständnis, dass Beanstandungen nur im nicht aufgebauten Zustand bearbeitet werden können!



Vergelijk eerst de lijst van materialen met de inhoud van uw pakket! Reclamaties kunnen alleen in behandeling worden genomen zolang de onderdelen nog niet zijn gemonteerd!



Confrontate questa distinta materiali prima con il contenuto del pacchetto! Vi preghiamo di comprendere che eventuali reclami possono essere accolti solo prima del montaggio!



First compare the list of materials with your package contents! Please understand that complaints can be processed in the non-built status only!



Start med at kontrollere materialelisten med indholdet af den leverede pakke! Vi gør venligst opmærksom på at reklamationer kun kan behandles for materialer som ikke er blevet bearbejdet!



Nejprve přezkontrolujte obsah balení podle materiálového listu! Mějte pochopení pro to, že případnou reklamaci se můžeme zabývat pouze tehdy, když díly nebudou smontované! Za pomoci tohoto seznamu můžete jednotlivé díly přiřadit k montážnímu návodu.



Commencez par comparer la liste du matériel avec le contenu de votre paquet! Sachez que nous traitons uniquement les réclamations concernant le matériel à l'état non monté!



En primer lugar, compare la lista de material con el contenido del paquete. Rogamos entienda que las reclamaciones sólo pueden ser tramitadas antes de montar el objeto!

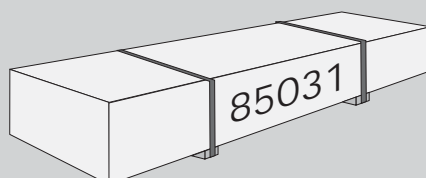

1 x W1	1920 x	433 x	68 mm	ID 25547
1 x W2	1920 x	606 x	68 mm	ID 25548

1 x W3	1920 x	606 x	68 mm	ID 25550

3 x W4	1920 x	606 x	57 mm	ID 23624

1 x W5	1920 x	606 x	57 mm	ID 23629

<div style="display: flex; align-items: center; gap: 10px;"> <div style="display: flex; flex-direction: column; gap: 5px;"> <div> Siehe Türpaket</div> <div> Opmerking Door Package</div> <div> Note Door Package</div> <div> Remarque Package porte</div> <div> Nota Paquete Puerta</div> <div> Nota Door Package</div> <div> Poznámka Door balíček</div> </div> </div>				
1 x W6				

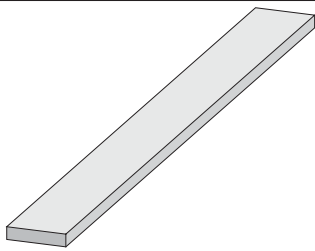

4 x B1	1920 x	19 x	3 mm	ID 20799
4 x B2	750 x	35 x	12 mm	ID 24239
4 x B3	1920 x	35 x	12 mm	ID 24846
4 x B4	1884 x	45 x	17 mm	ID 48037
2 x B5	70 x	45 x	18 mm	ID 26366
4 x B6	800 x	45 x	18 mm	ID 24796
4 x B7	480 x	95 x	18 mm	ID 20930
4 x B8	580 x	95 x	18 mm	ID 16708
1 x B9	1284 x	95 x	18 mm	ID 20613
1 x B10	1325 x	95 x	18 mm	ID 34176
1 x B11	300 x	120 x	18 mm	ID 22467
2 x B12	530 x	42 x	28 mm	ID 43954
2 x B13	1154 x	42 x	28 mm	ID 49446
2 x B14	1209 x	42 x	28 mm	ID 24124
4 x B15	1235 x	42 x	28 mm	ID 49464
4 x B16	1318 x	42 x	28 mm	ID 26353
3 x B17	1874 x	52 x	52 mm	ID 26165

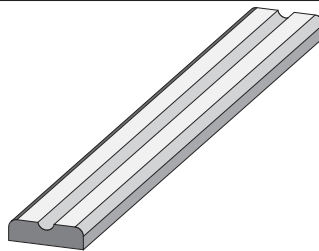

1 x L2	1204 x	90 x	22 mm	ID 49448
--------	--------	------	-------	----------

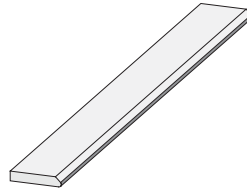

2 x G1	1980 x	95 x	17 mm	ID 48540
--------	--------	------	-------	----------

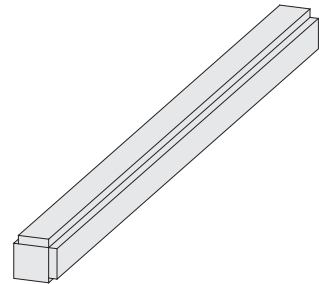

1 x K1	1874 x	64 x	64 mm	ID 24725
--------	--------	------	-------	----------

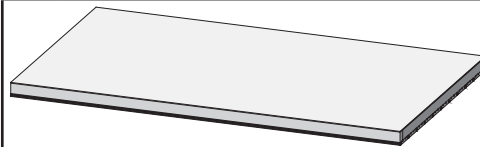

2 x M1	1232 x	618 x	57 mm	ID 49467
--------	--------	-------	-------	----------

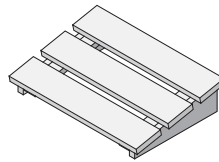

1 x				ID 20708
-----	--	--	--	----------

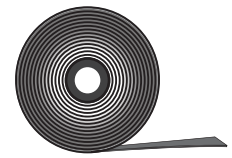

10m				ID 14025
-----	--	--	--	----------

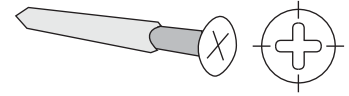

190 x	4 x	30 mm		ID 3686
80 x	4 x	50 mm		ID 3688
50 x	4 x	70 mm		ID 3689
80 x	4,5 x	80 mm		ID 9204
40 x	6 x	60 mm		ID 14014

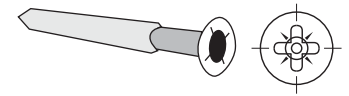

120 x	4,5 x	40 mm		ID 26285
-------	-------	-------	--	----------



6 x S1				ID 14266
--------	--	--	--	----------



150 x S2	4,5 x	30 mm		ID 26116
16 x S3	12 x	18 mm		ID 46403

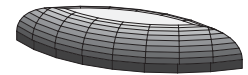

4 x T1				ID 26272
--------	--	--	--	----------

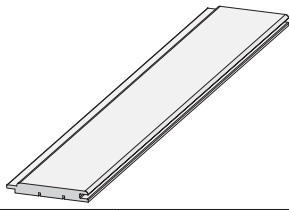

2 x E1	1920 x	97 x	12 mm	ID 22863
--------	--------	------	-------	----------

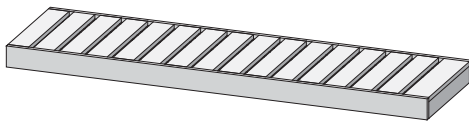

1 x L1	1204 x	500 x	90 mm	ID 49469
--------	--------	-------	-------	----------

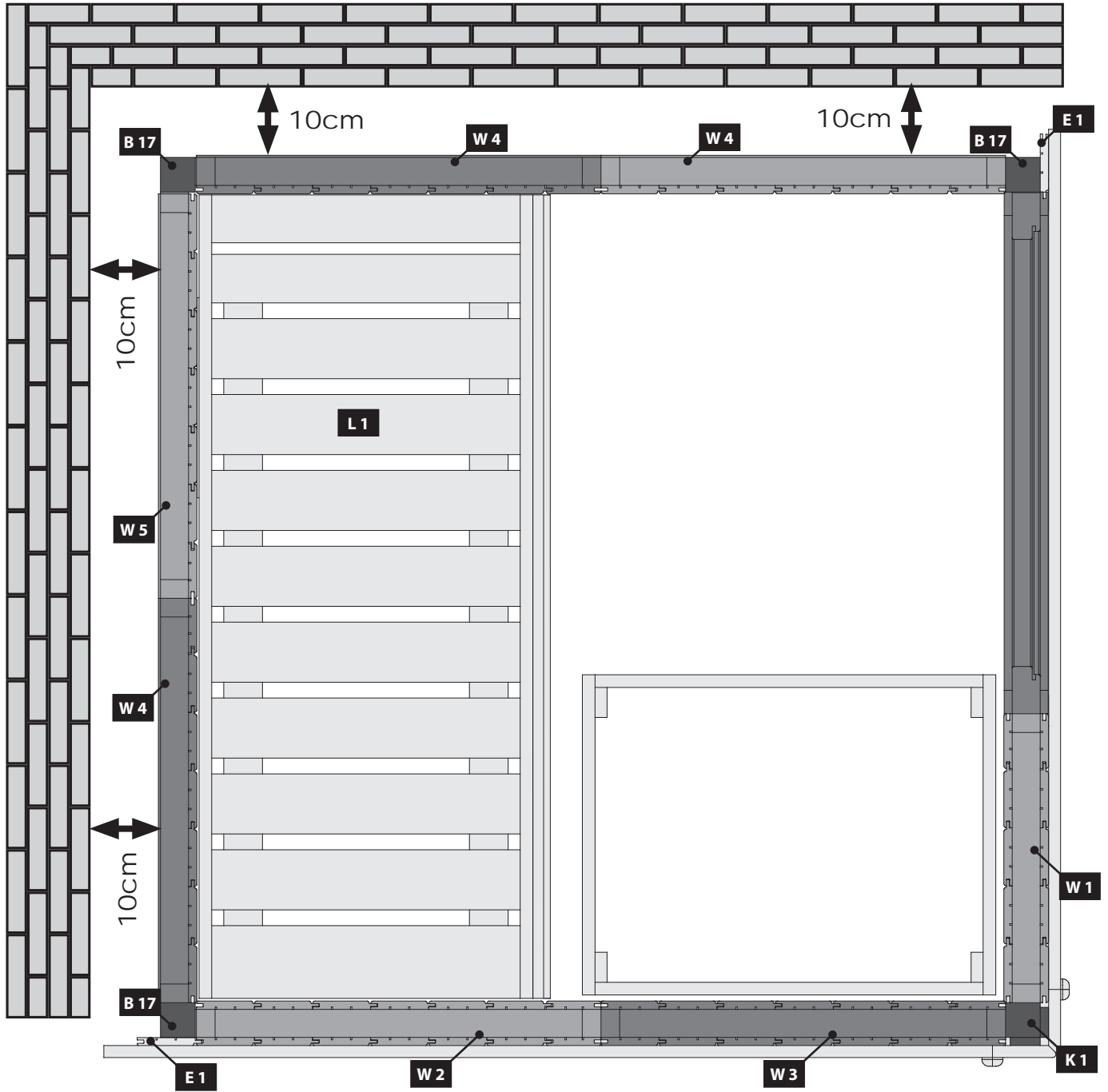

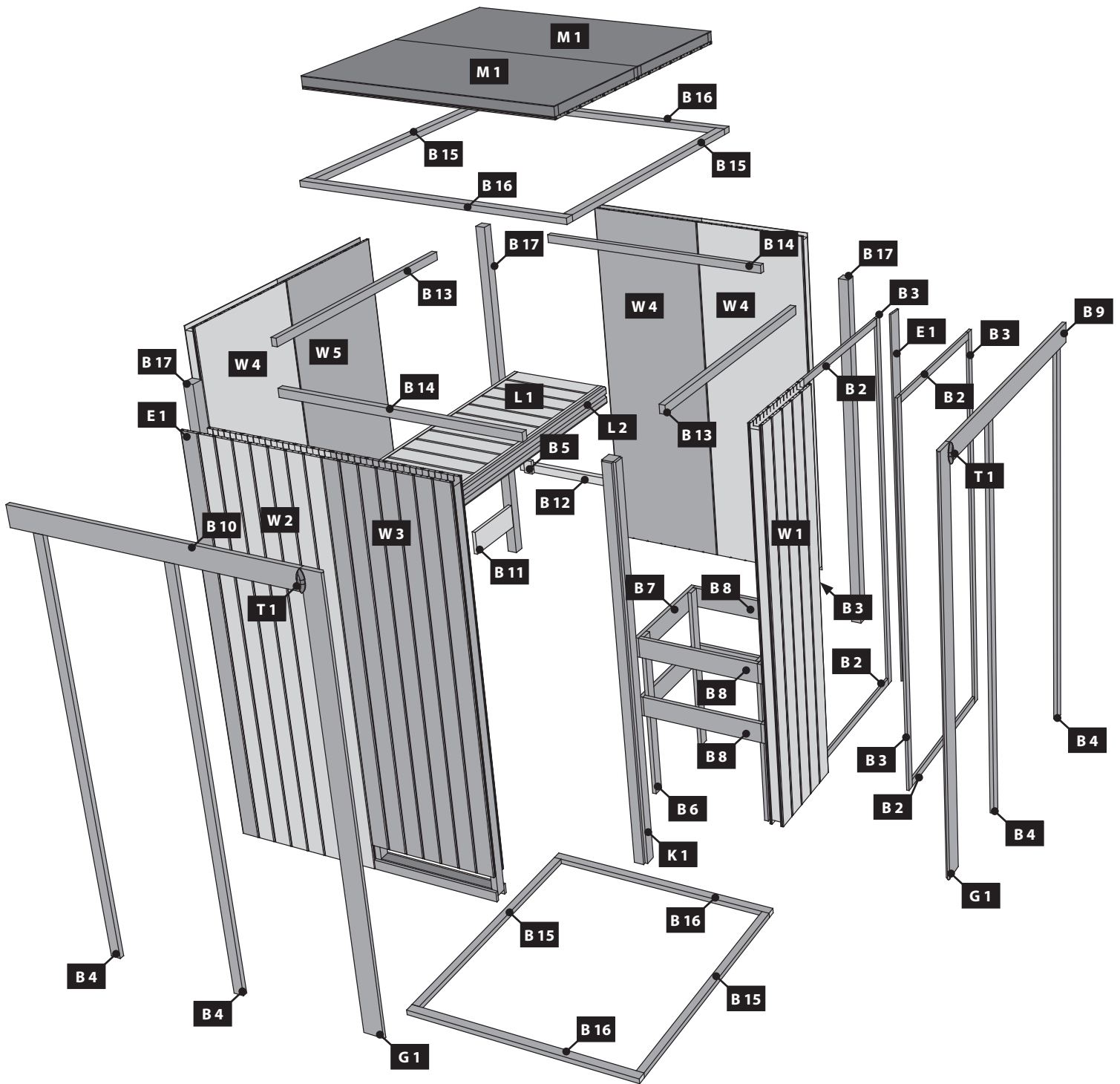

01 2x

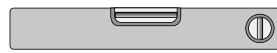

Ø3 mm 4x70

8x

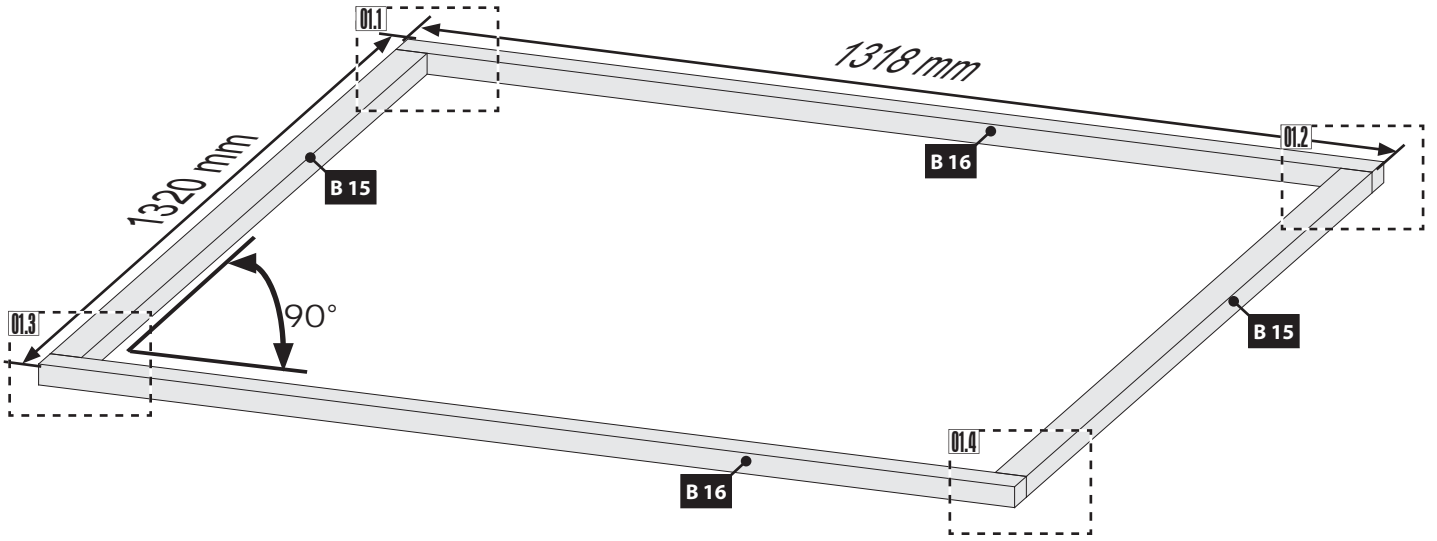
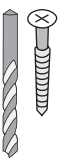

01.1

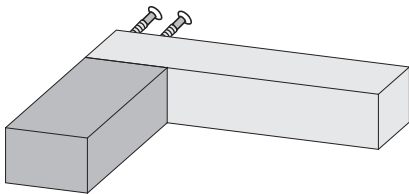

01.2

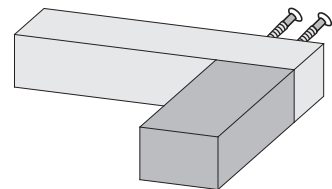

01.3

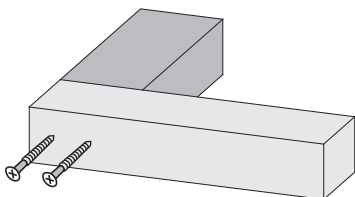

01.4

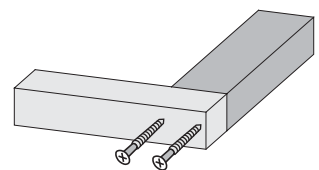

02

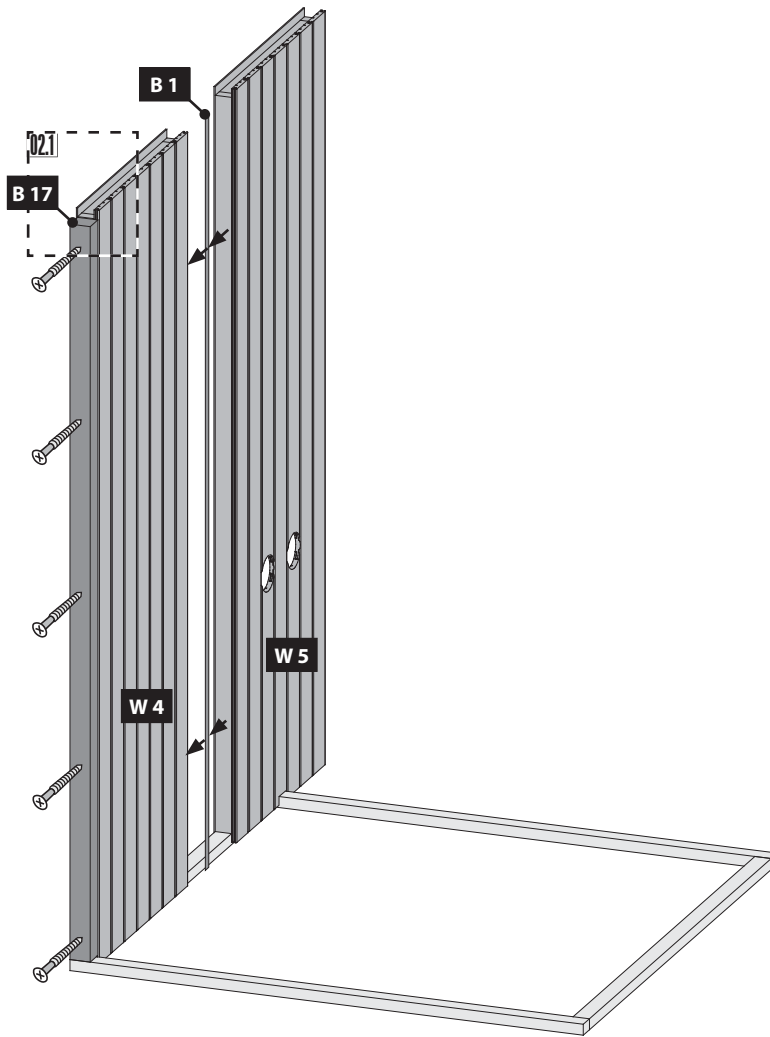

Ø4 mm 4,5×80

5x

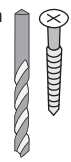

02.1

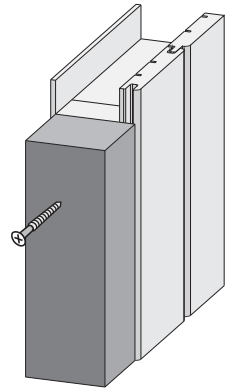

03

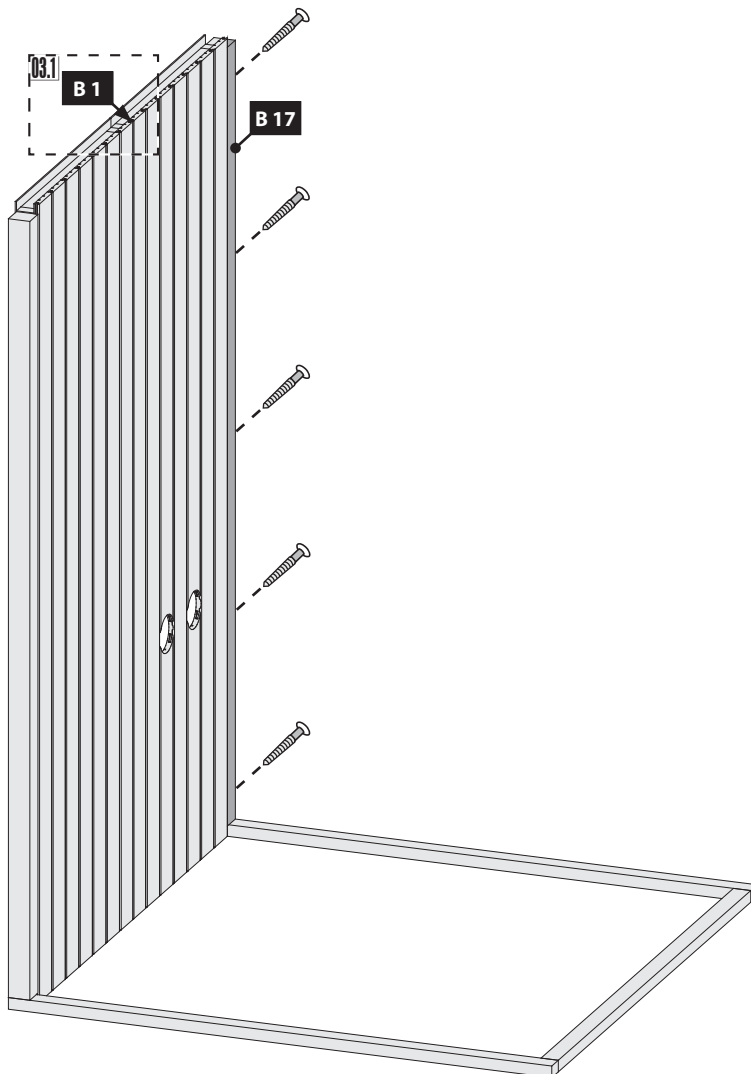

Ø4 mm 4,5×80

5x

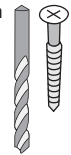

03.1

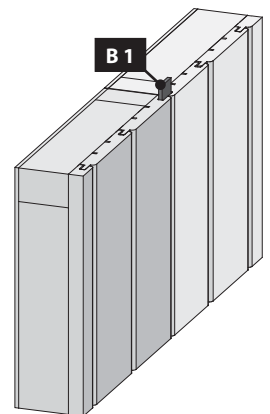

04

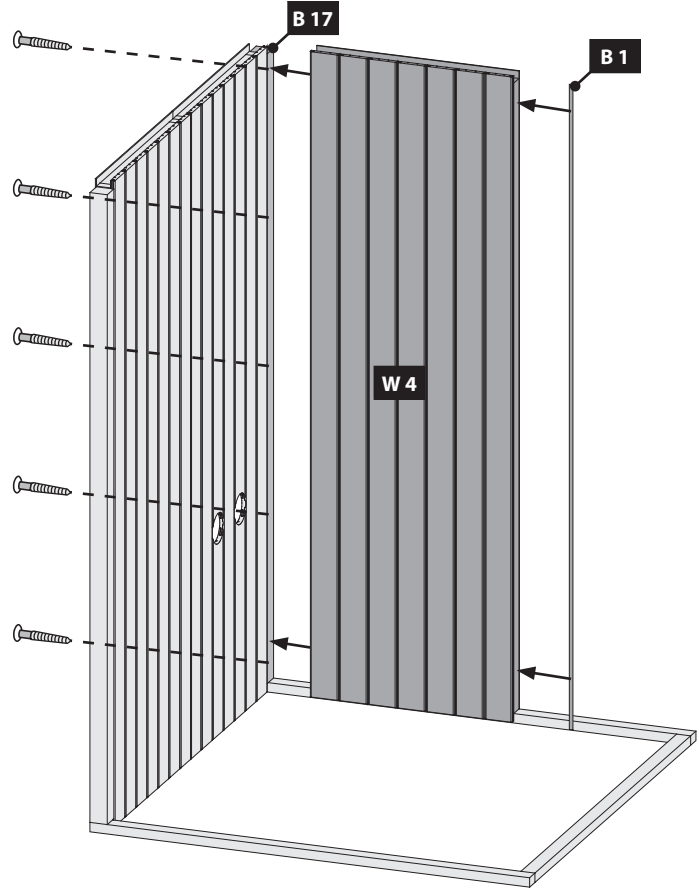

Ø4 mm 4,5×80



5x

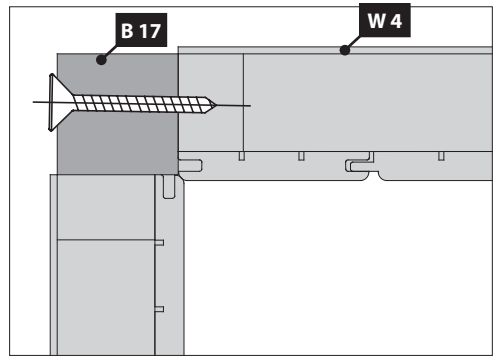
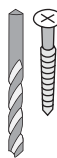

05

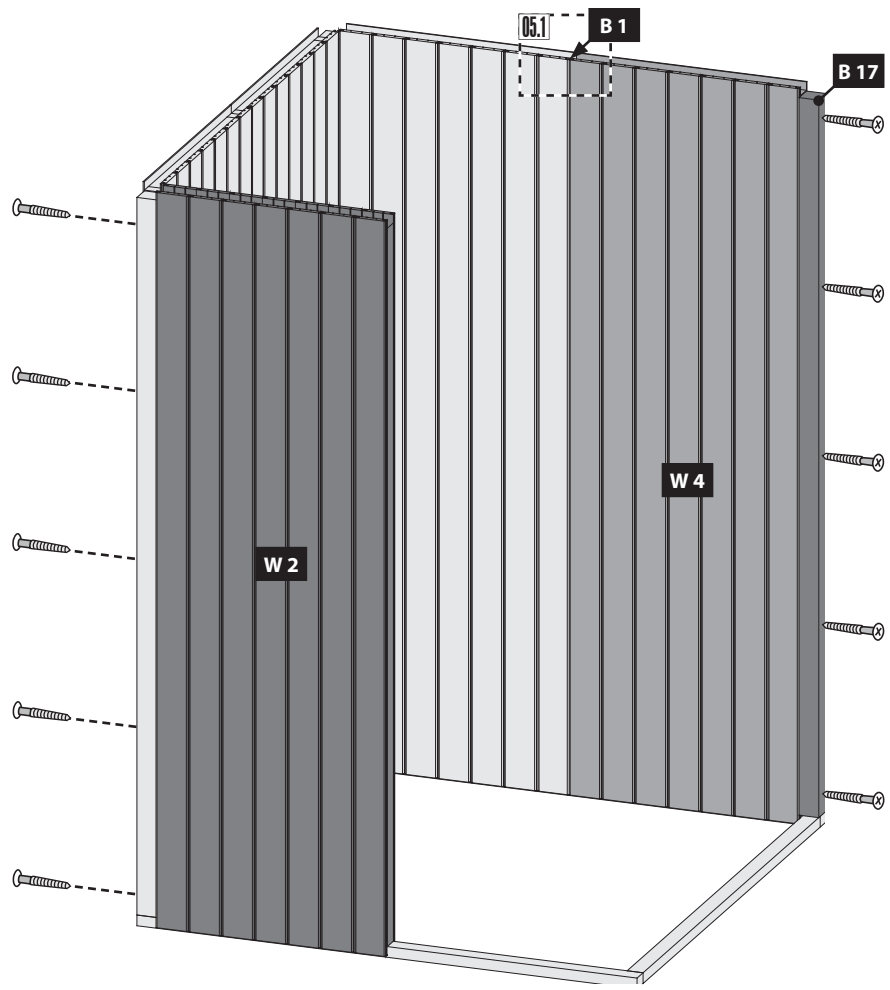

Ø4 mm 4,5×80

5x

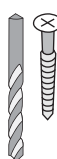

05.1

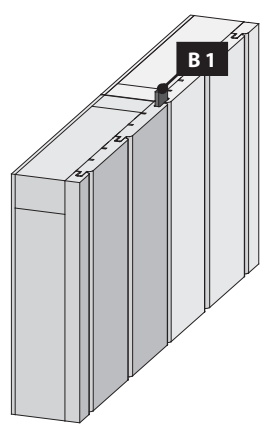



06

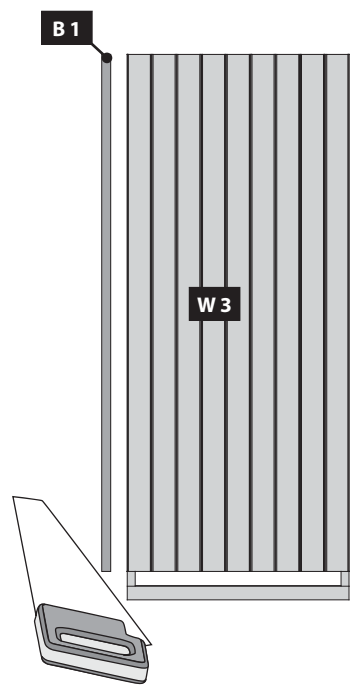
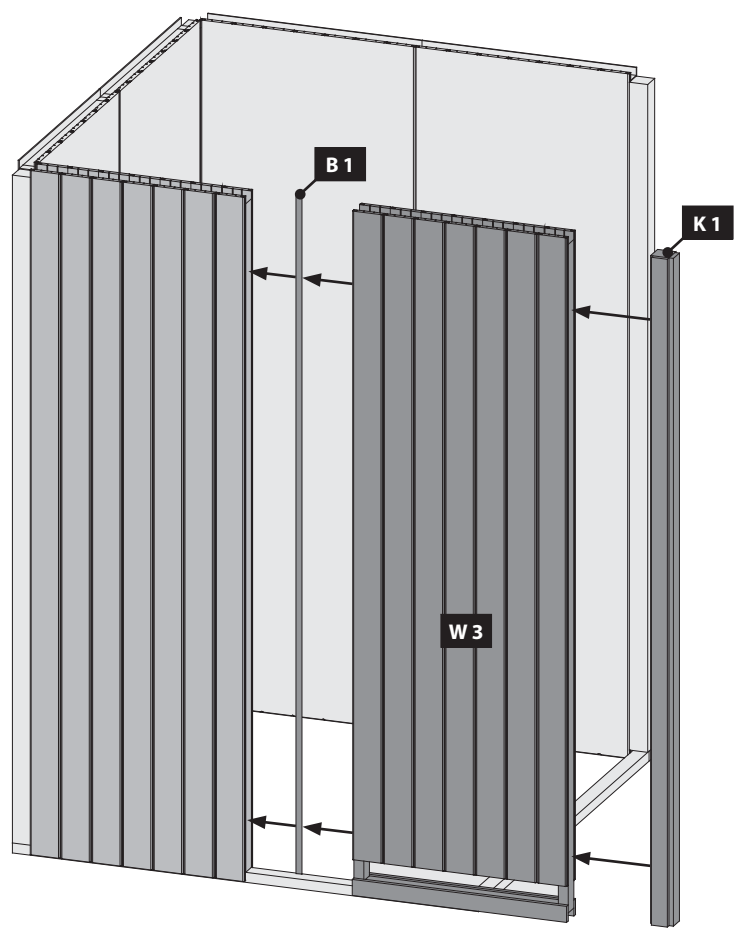

07

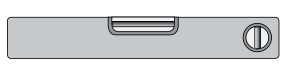
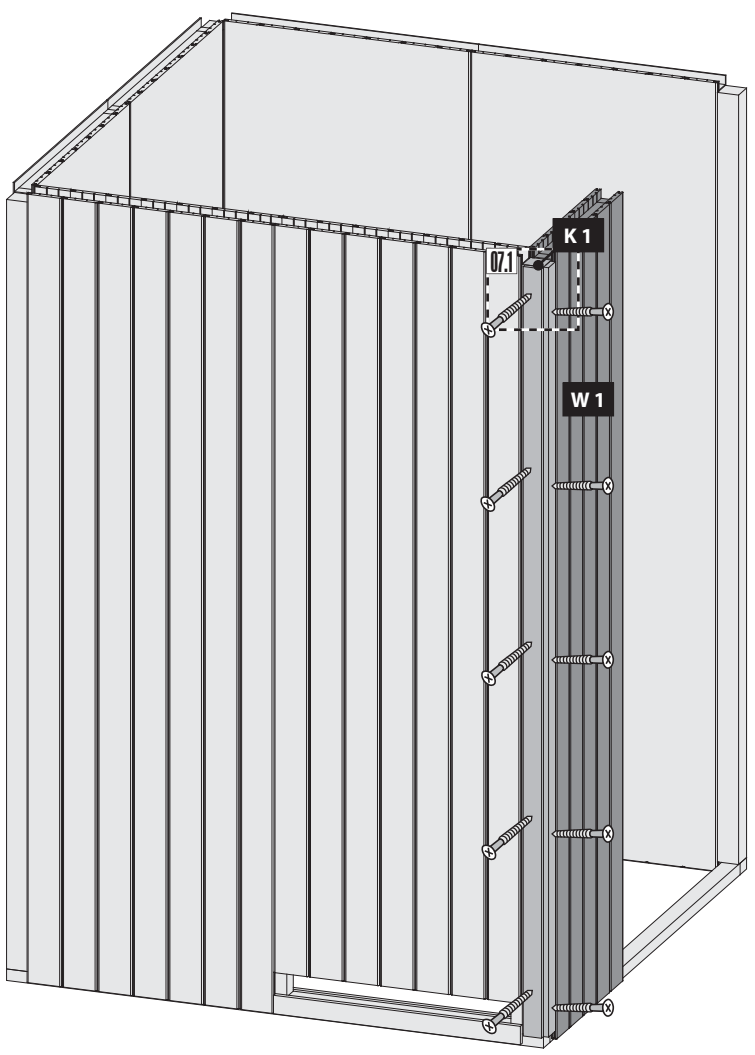

Ø4 mm 4,5×80  
10x

07.1

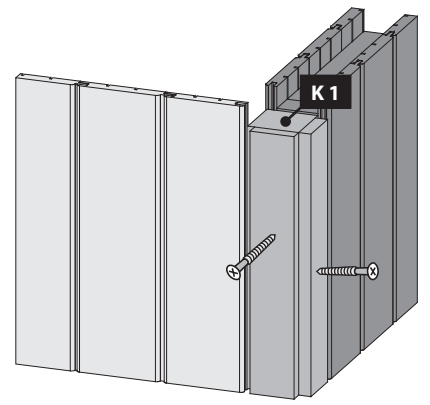



Einbau Glastür

Montage porte en verre

Installation of glass door

Montage van de glazen deur

Montaje de la puerta de cristal

Installazione portello di vetro

**!!! 01 — 03 !!!**

**08**

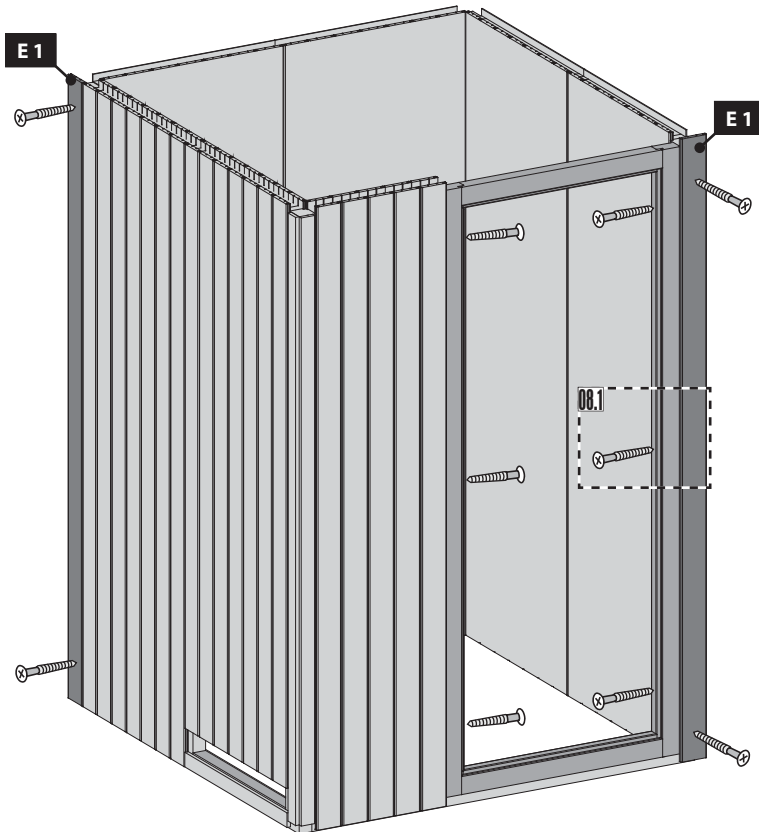

Ø4 mm 4,5x40

4x

4x

S2

**08.1-1**

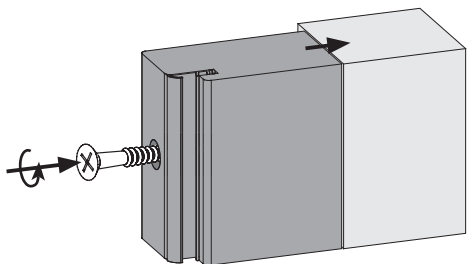

Ø4 mm S1

6x

**08.1-2**

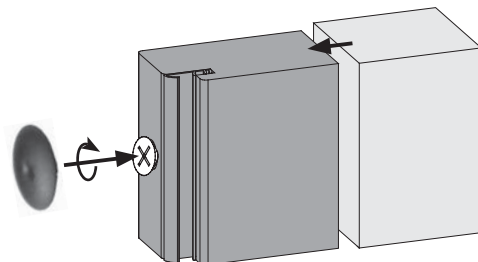

6x S3

**09**

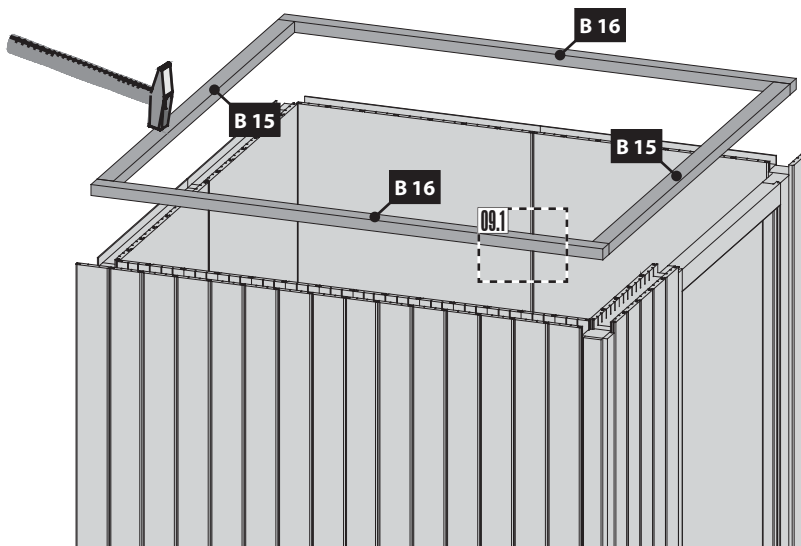

**09.1**

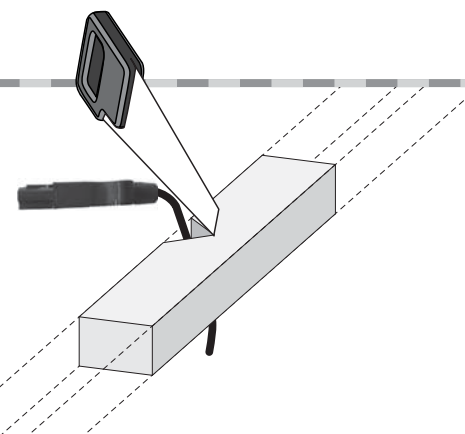

10 4x

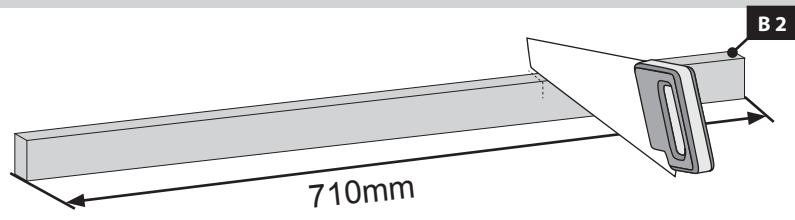

11

Ø4 mm 4,5x40

28x

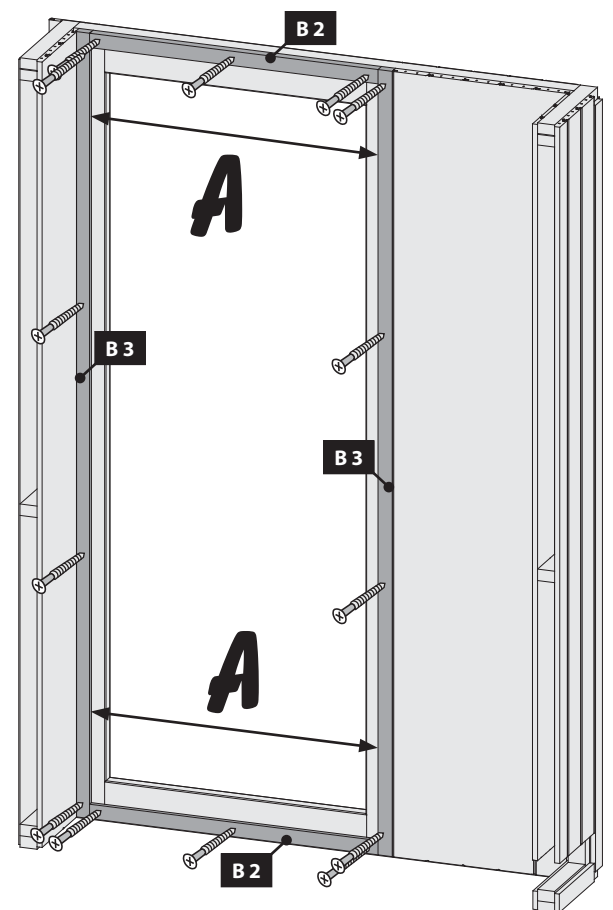
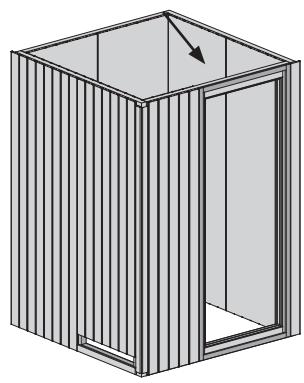
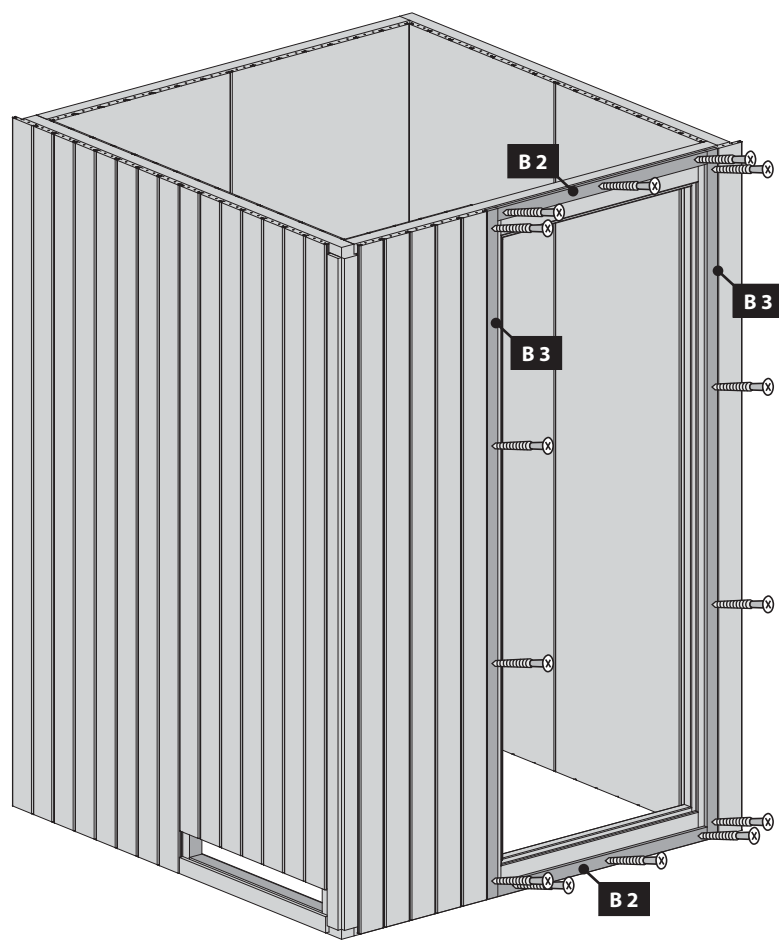

12

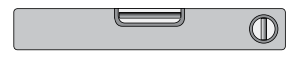
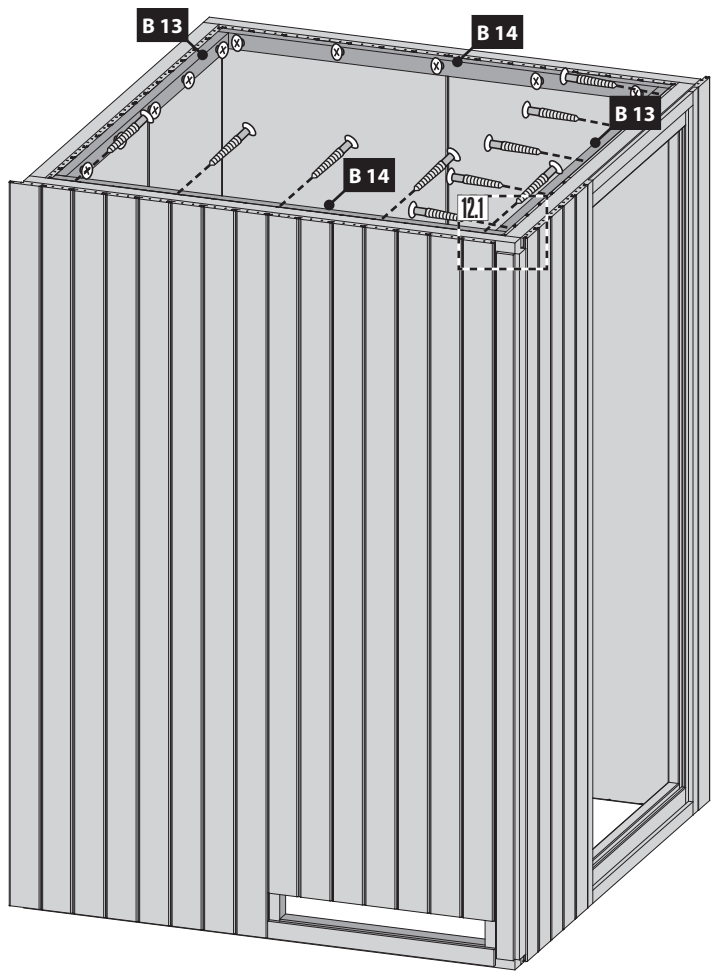

Ø3 mm 4x50



12.1

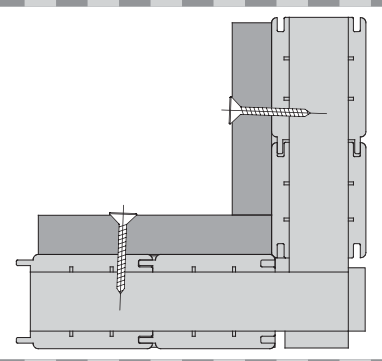

13

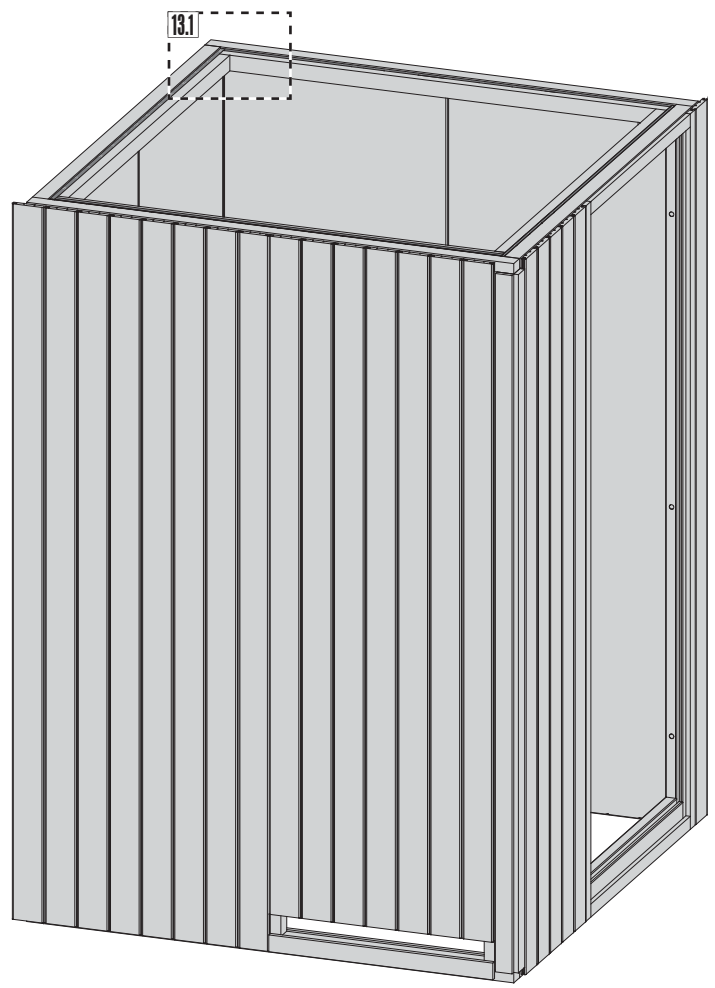
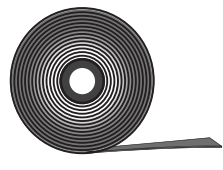
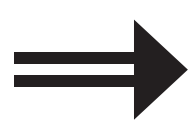

13.1

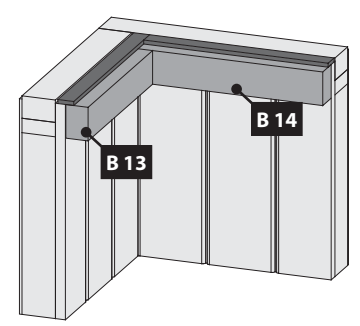

18x

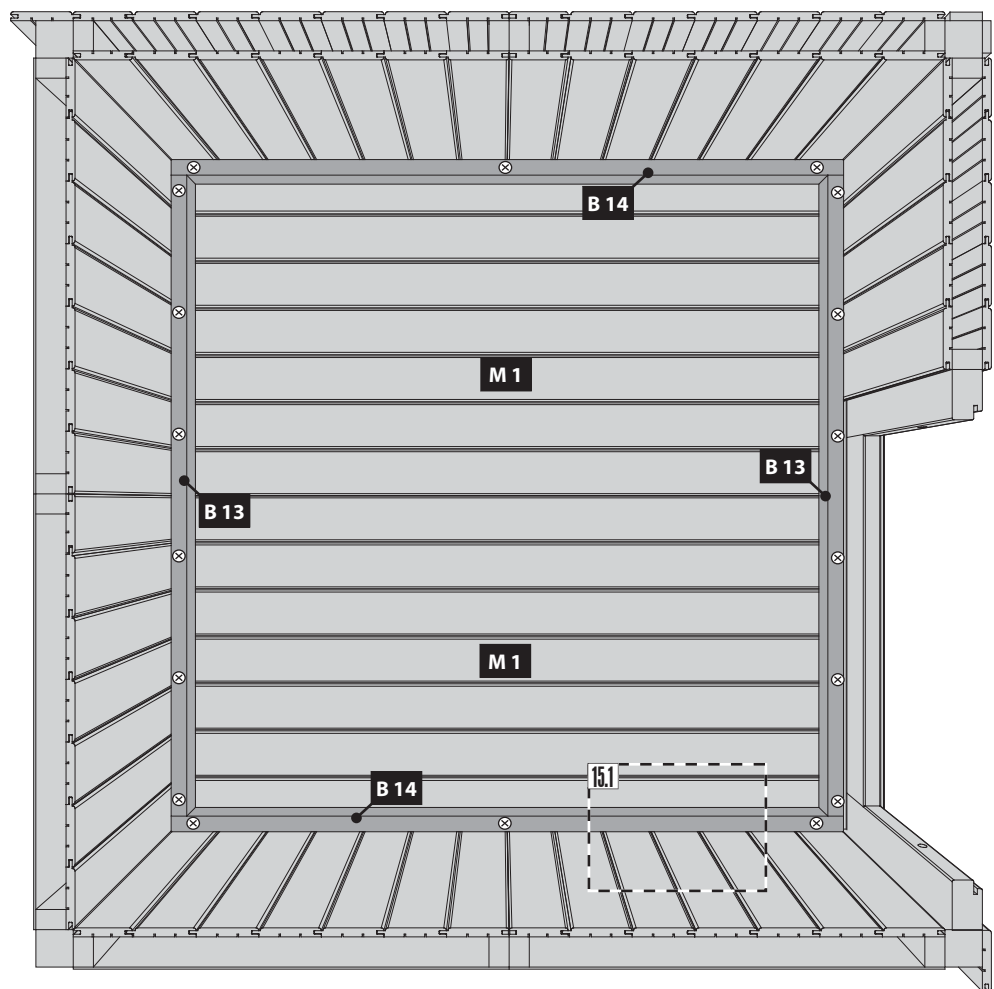
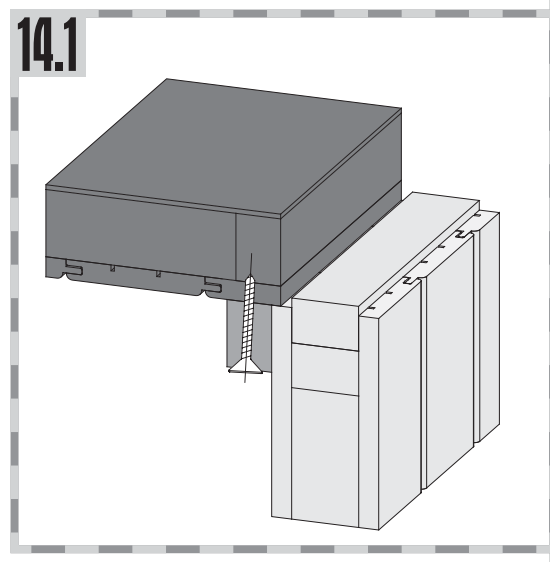
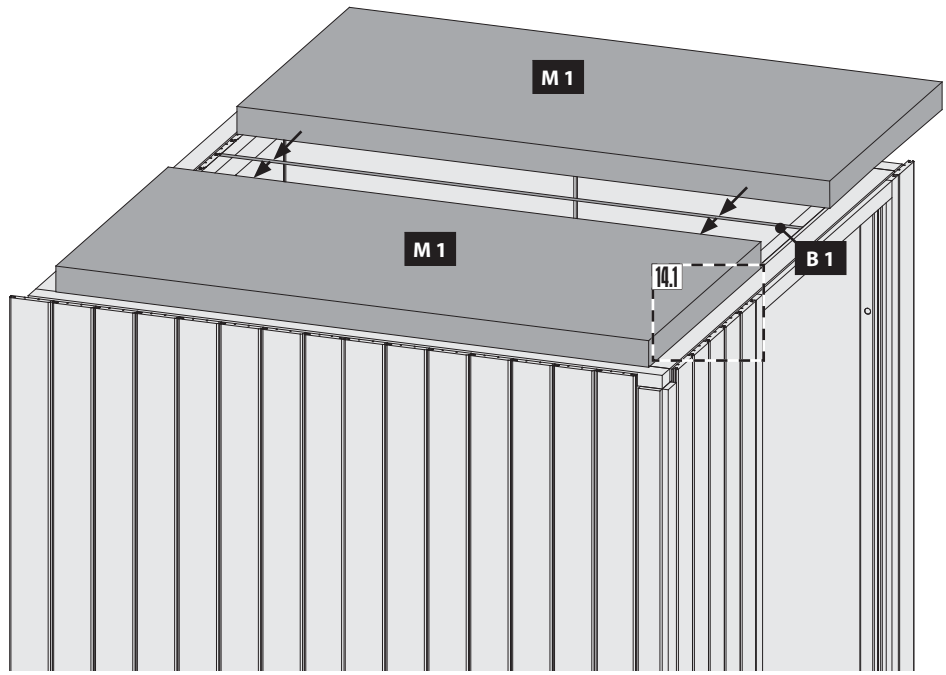
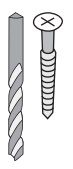

-  Ansicht von unten!
-  View from below
-  Vue d'en bas
-  Zicht van onderaf
-  Se nedefra
-  Ver desde abajo
-  Vista dal basso
-  Pohled shora !

30x

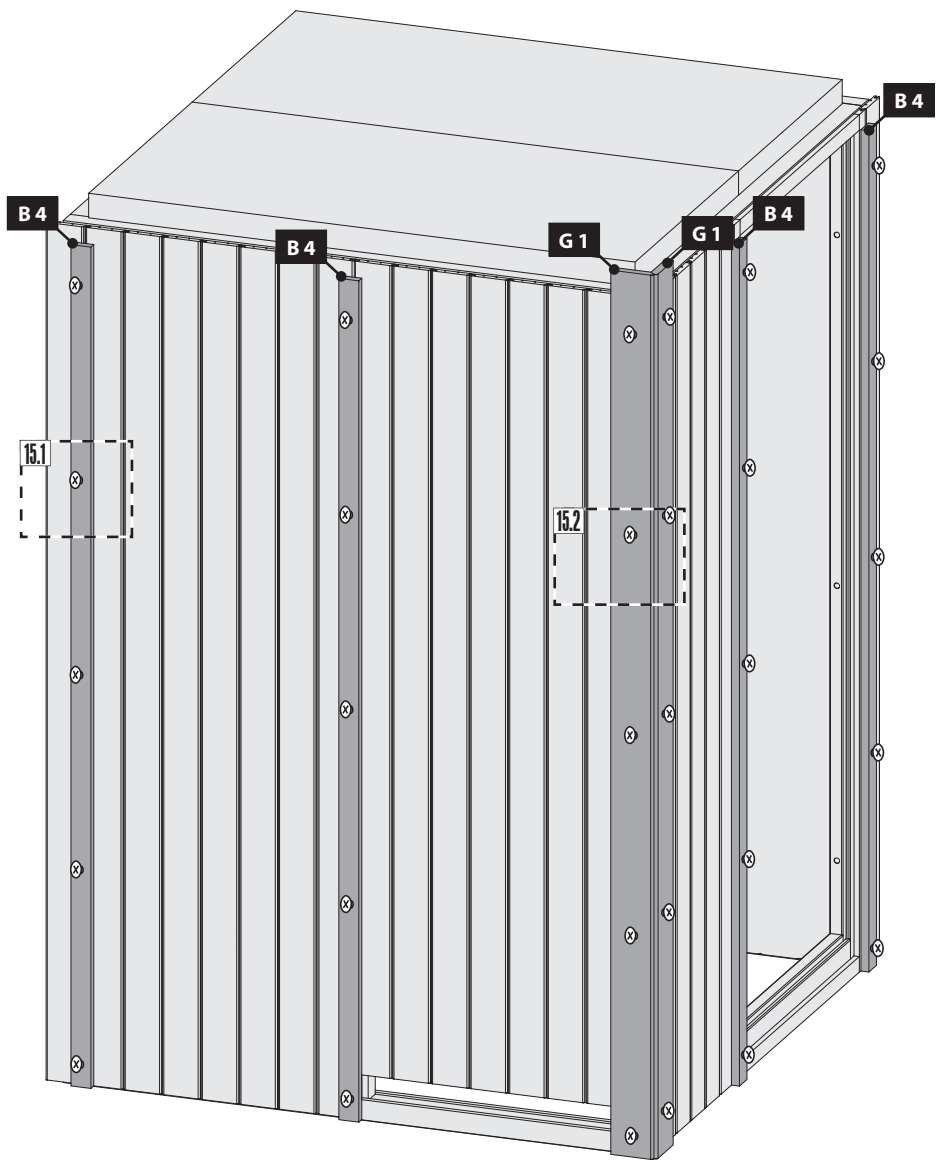
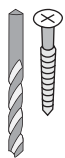

15.1

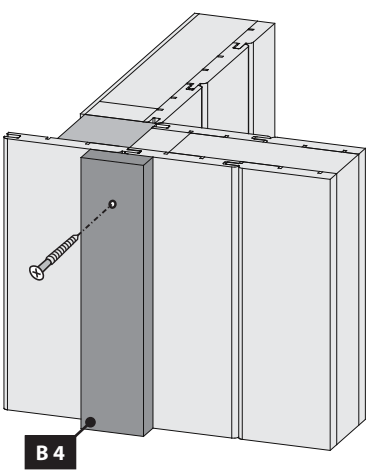

15.2

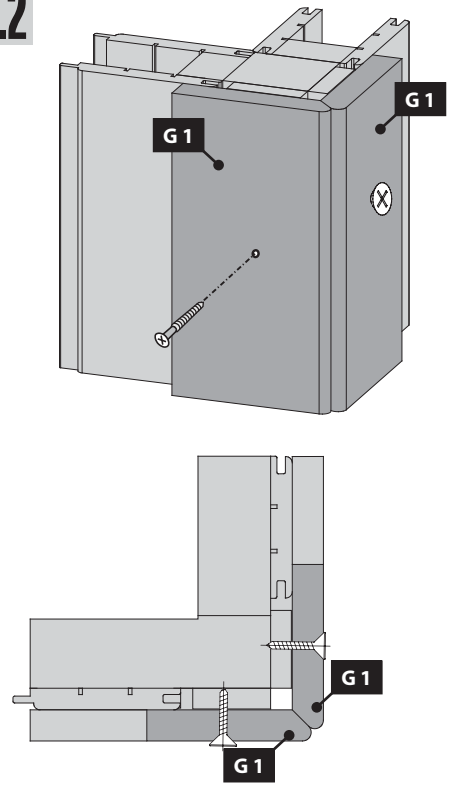

16

30x

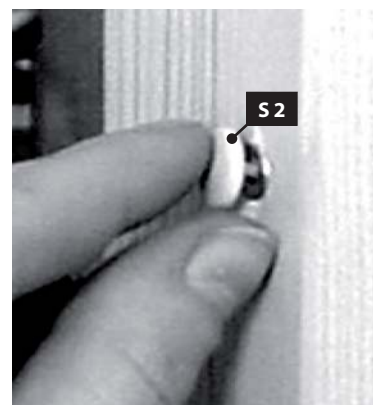

Ø4 mm 4,5x40

12x

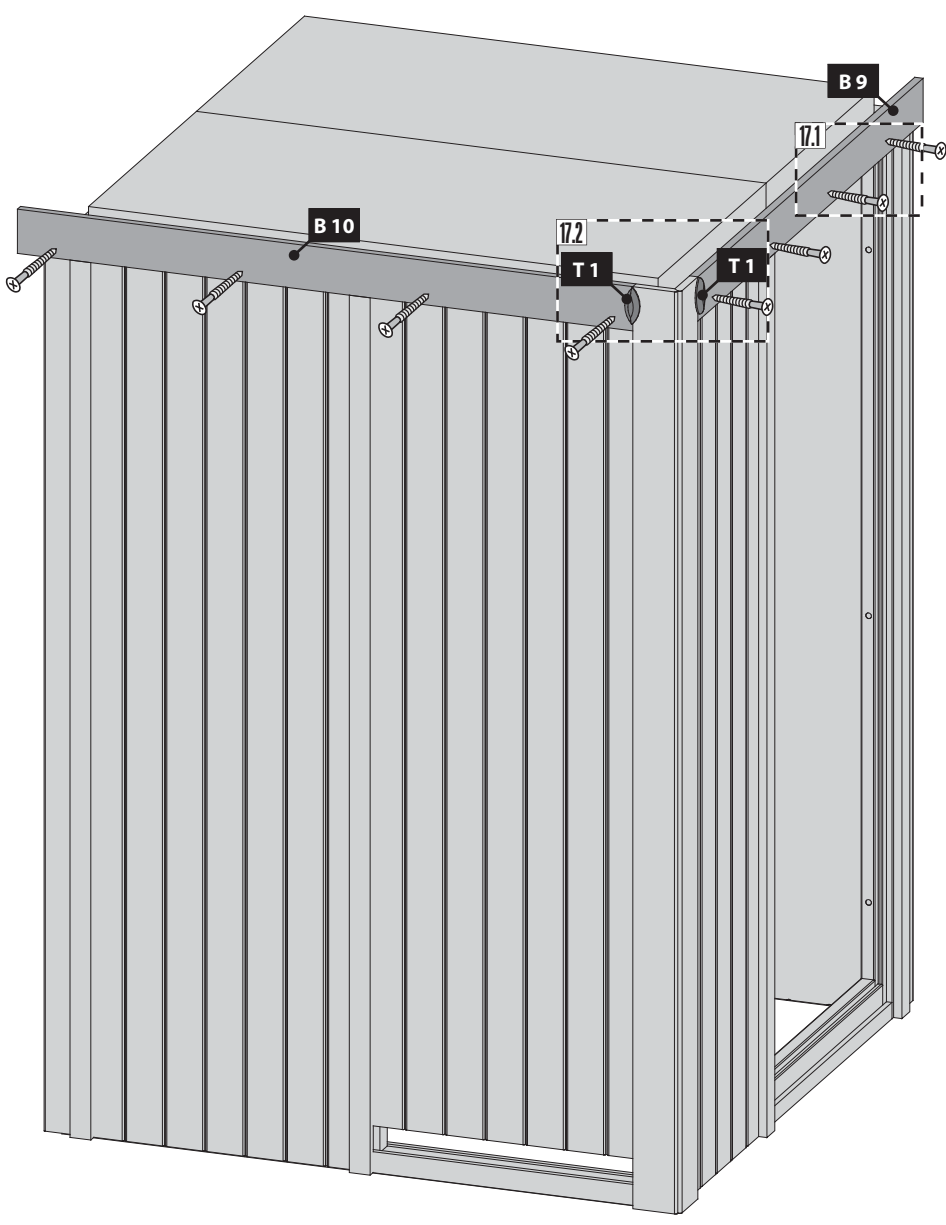
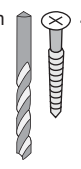

17.1

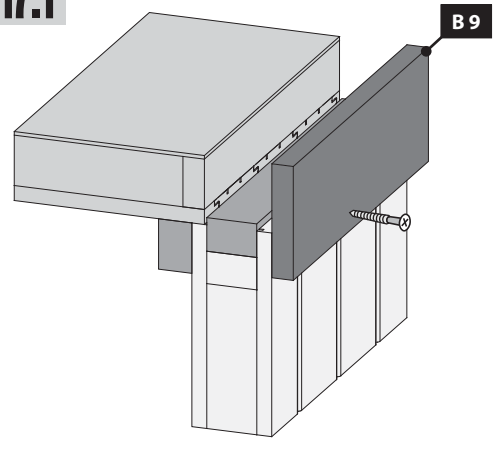

17.2

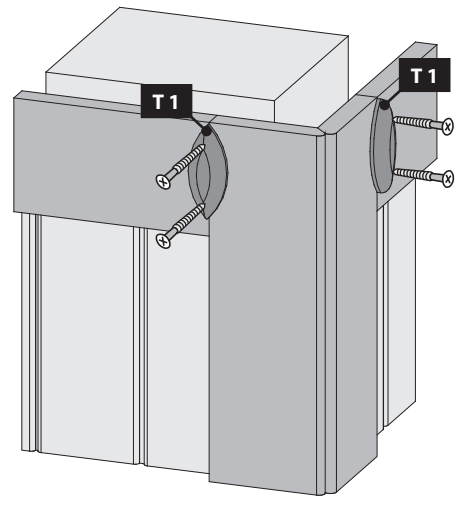

18

12x

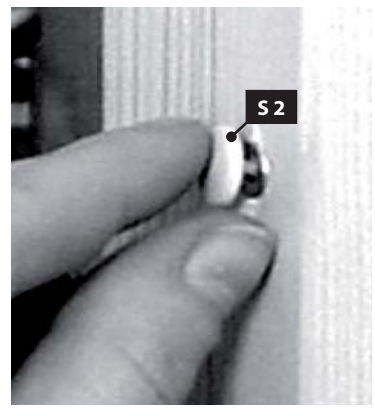

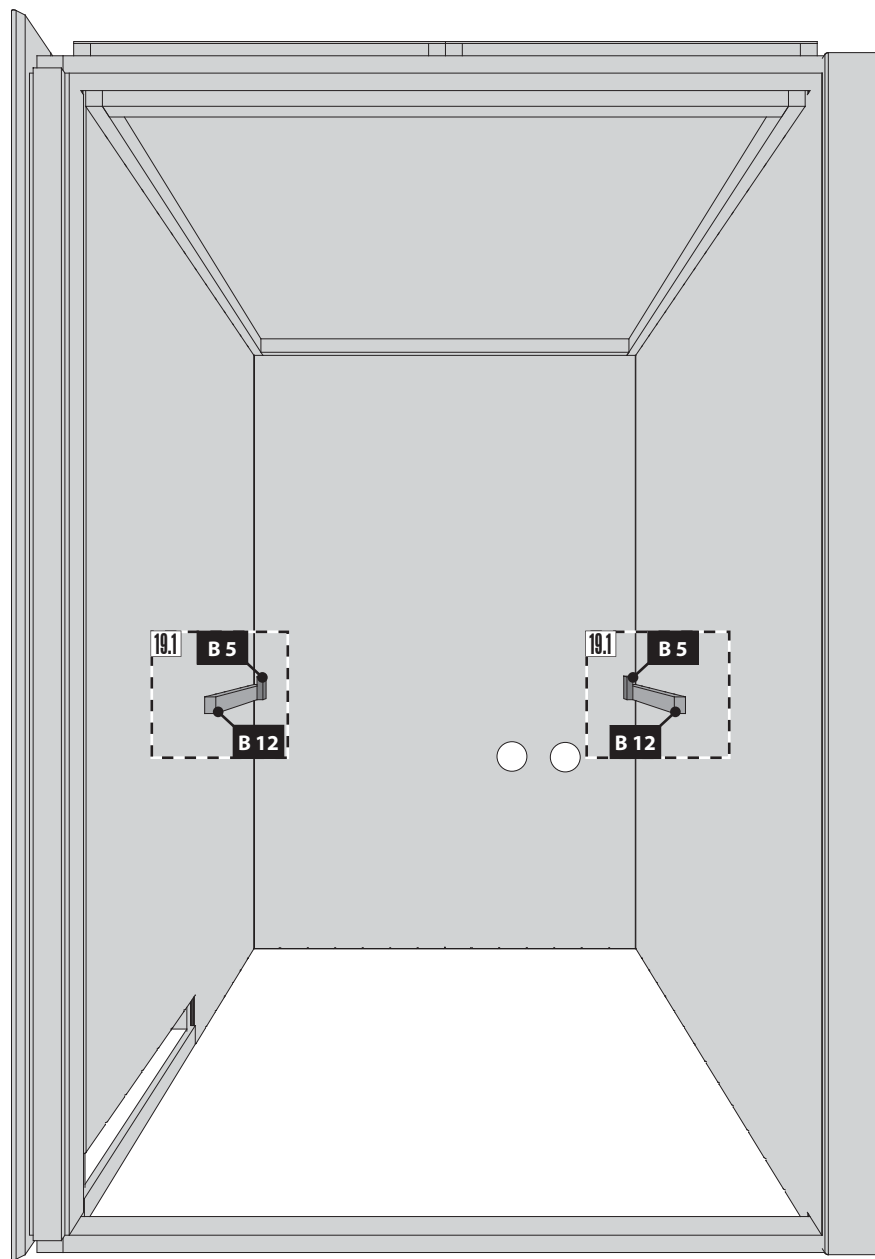

19.1-1

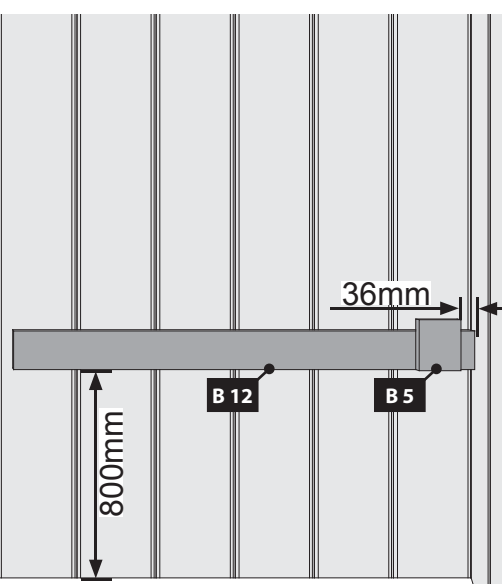

19.1-2

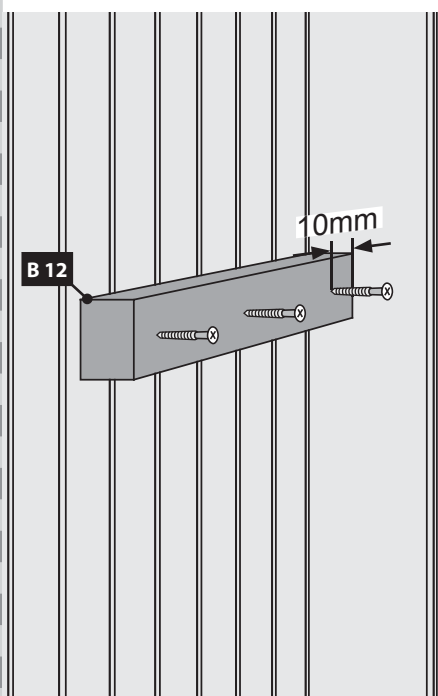
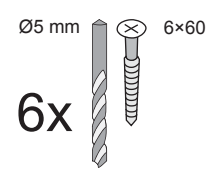

19.1-3

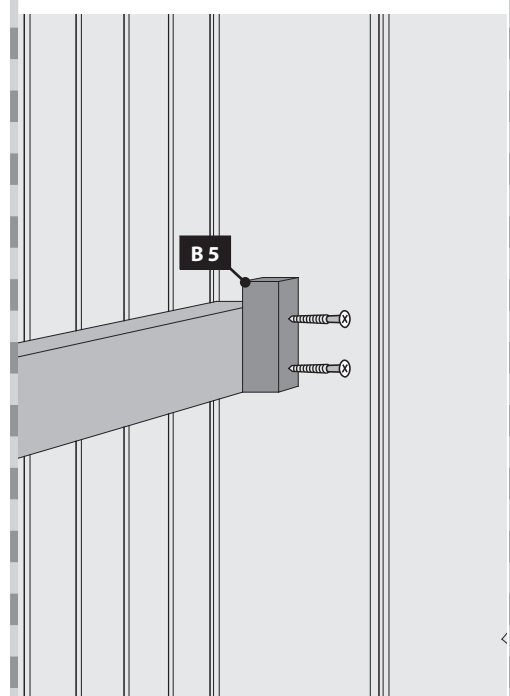
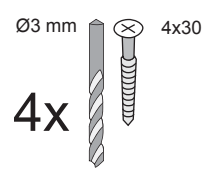



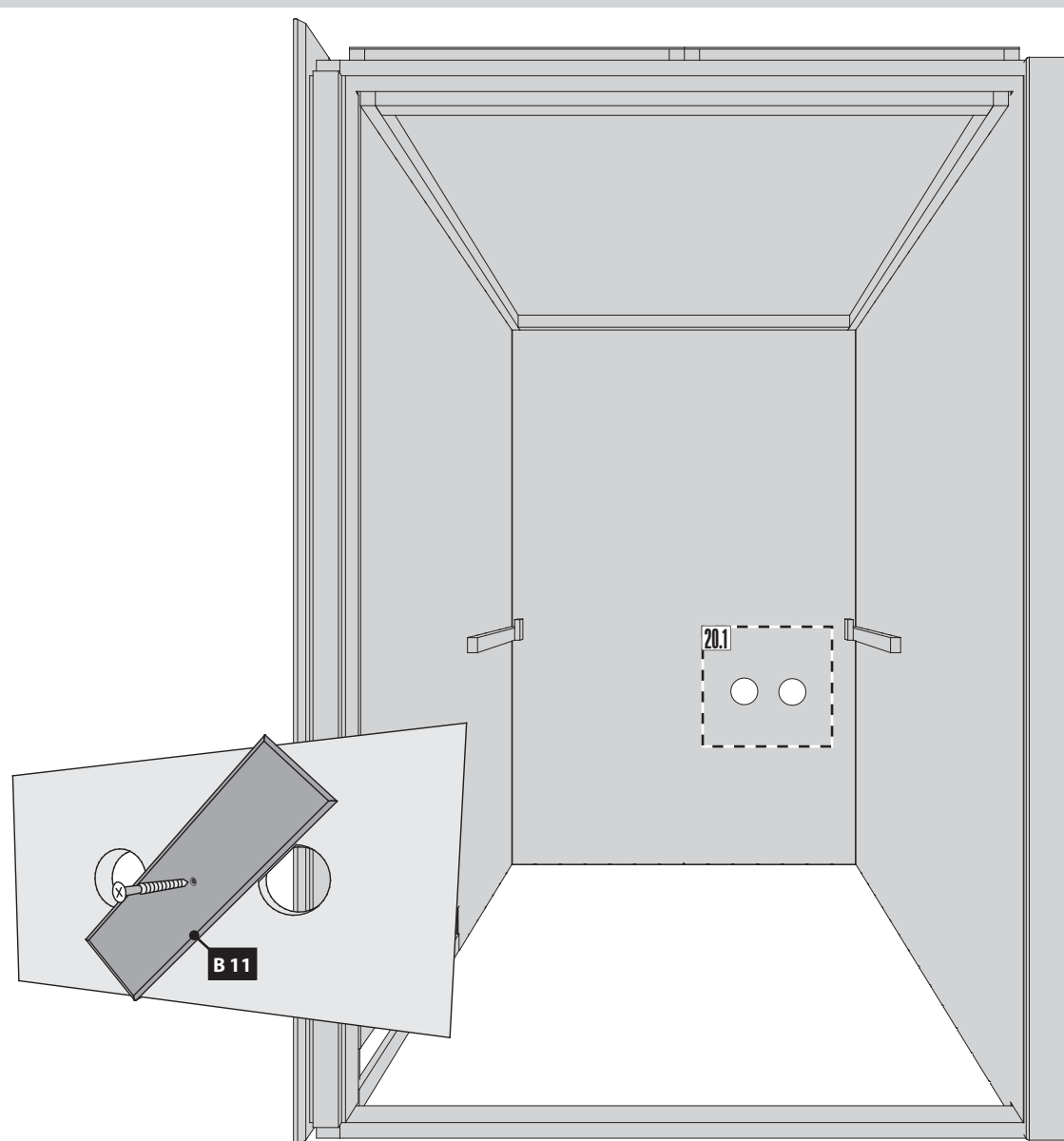
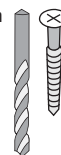



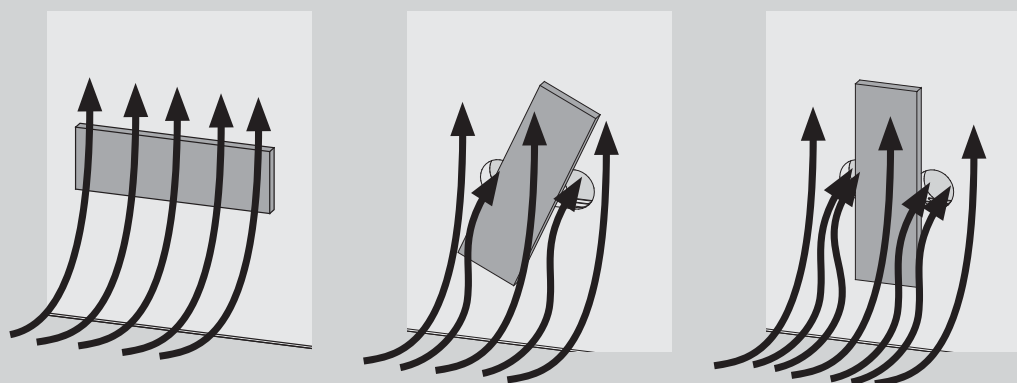

## 20.1





 Hier ist die Funktionsweise des Brettes abgebildet. Regeln Sie damit die Abluft nach Ihren eigenen Wünschen.

 Ceci représente le mode de fonctionnement de la planche. Avec elle, réglez l'écoulement de l'air selon vos désirs.

 This figure shows the functional principle of the board. Regulate the exhaust air according to your own wishes.

 Hier is de werking van het plankje afgebeeld. Regel daarmee de luchtafvoer naar eigen wens.

 Aquí está representada la forma de funcionamiento de la tabla. Regule con ello el aire de salida según sus propios deseos.

 Viene illustrato il principio di funzionamento della tavoletta di regolazione della ventilazione. Con essa si può regolare a piacere la ventilazione.

 Zde je zobrazená funkce desky. Regulujte s ní odsávací vzduch dle Vašeho přání.

21

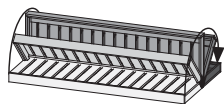

Ø3 mm 4x50

5x

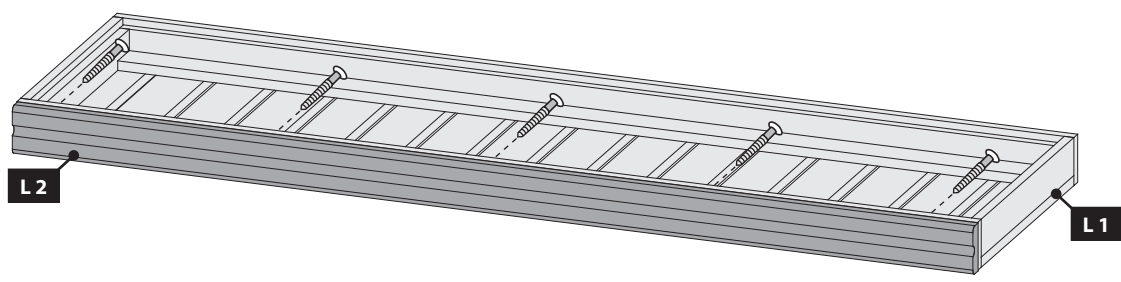
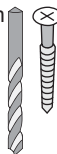

22

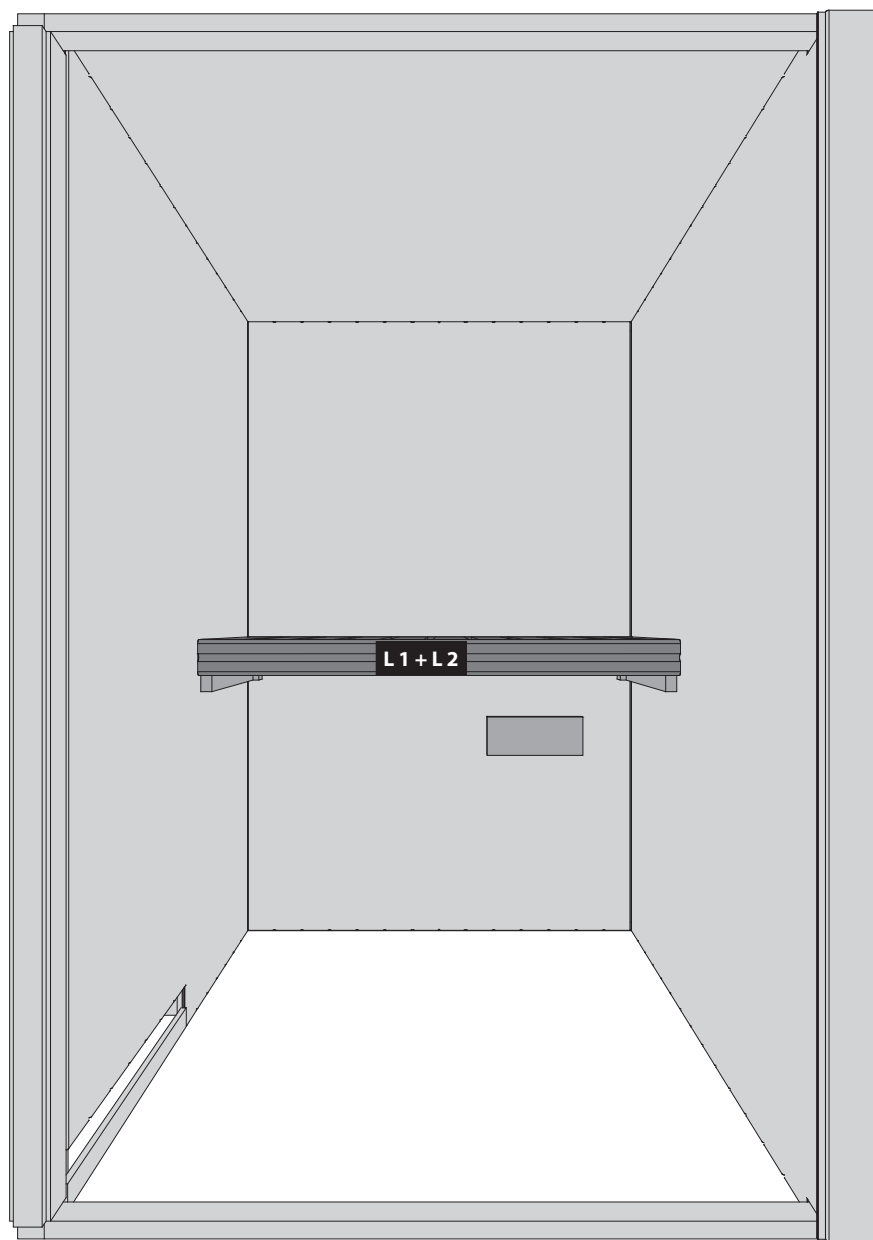

# 23 2x

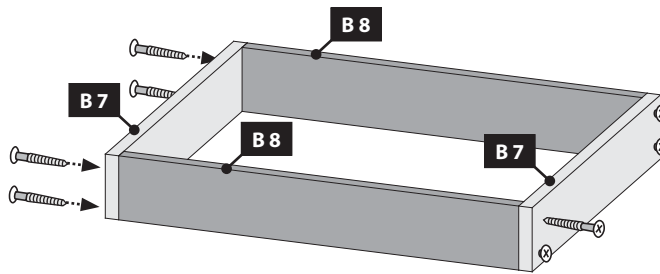

Ø3 mm 4x30

8x



# 23 a

-  Nur bei 9 kW-Ofen
-  Seulement 9 kW chauffe
-  Only 9 kW heater
-  Slechts 9 kW heater
-  Sólo calentador de 9 kW
-  Solo riscaldamento 9 kW
-  Pouze topné těleso 9 kW

Ø3 mm 4x30

16x

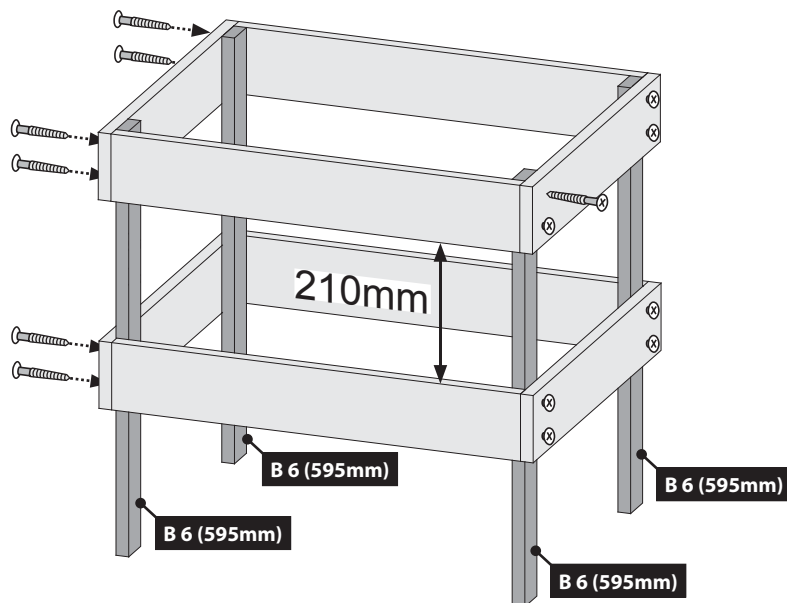

4x

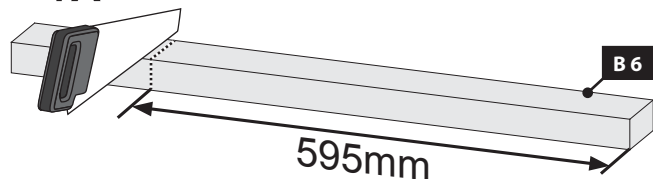

# 23 b

-  Bei allen anderen Öfen
-  Pour tous les autres fours
-  For all other furnaces
-  Voor alle andere ovens
-  Para todos los otros hornos
-  Per tutti gli altri tipi di forni
-  U všech ostatních pecích

Ø3 mm 4x30



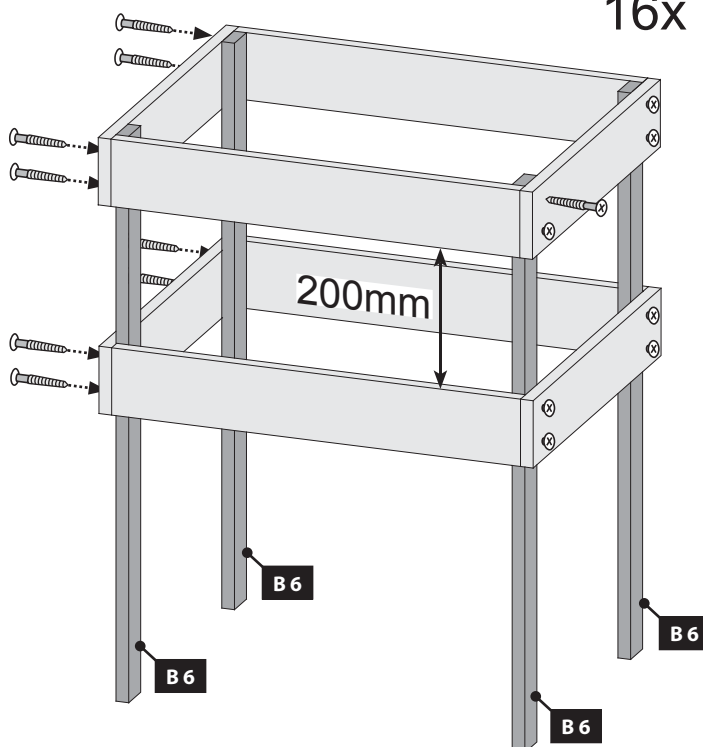



16x

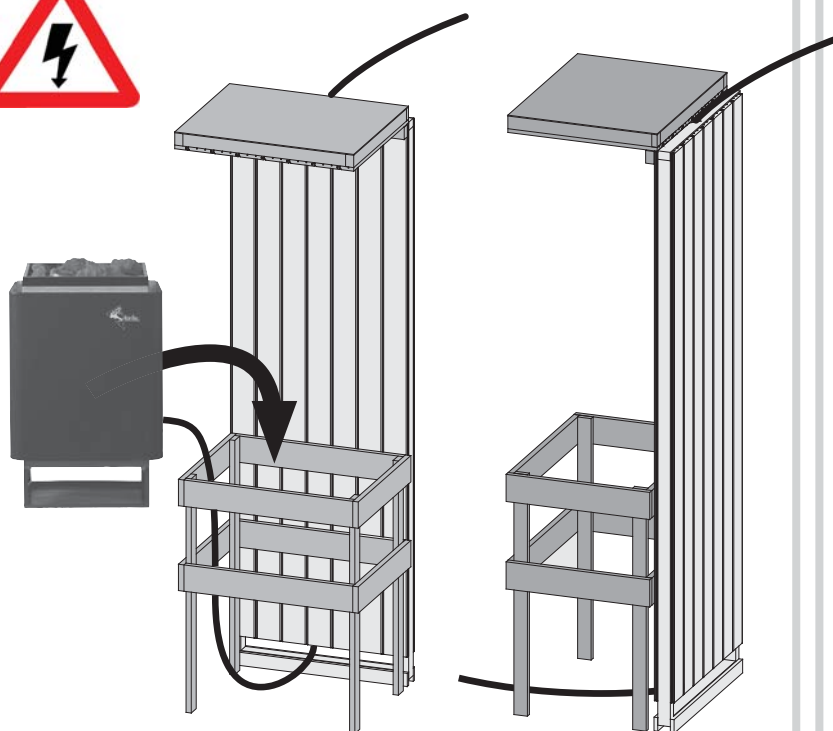
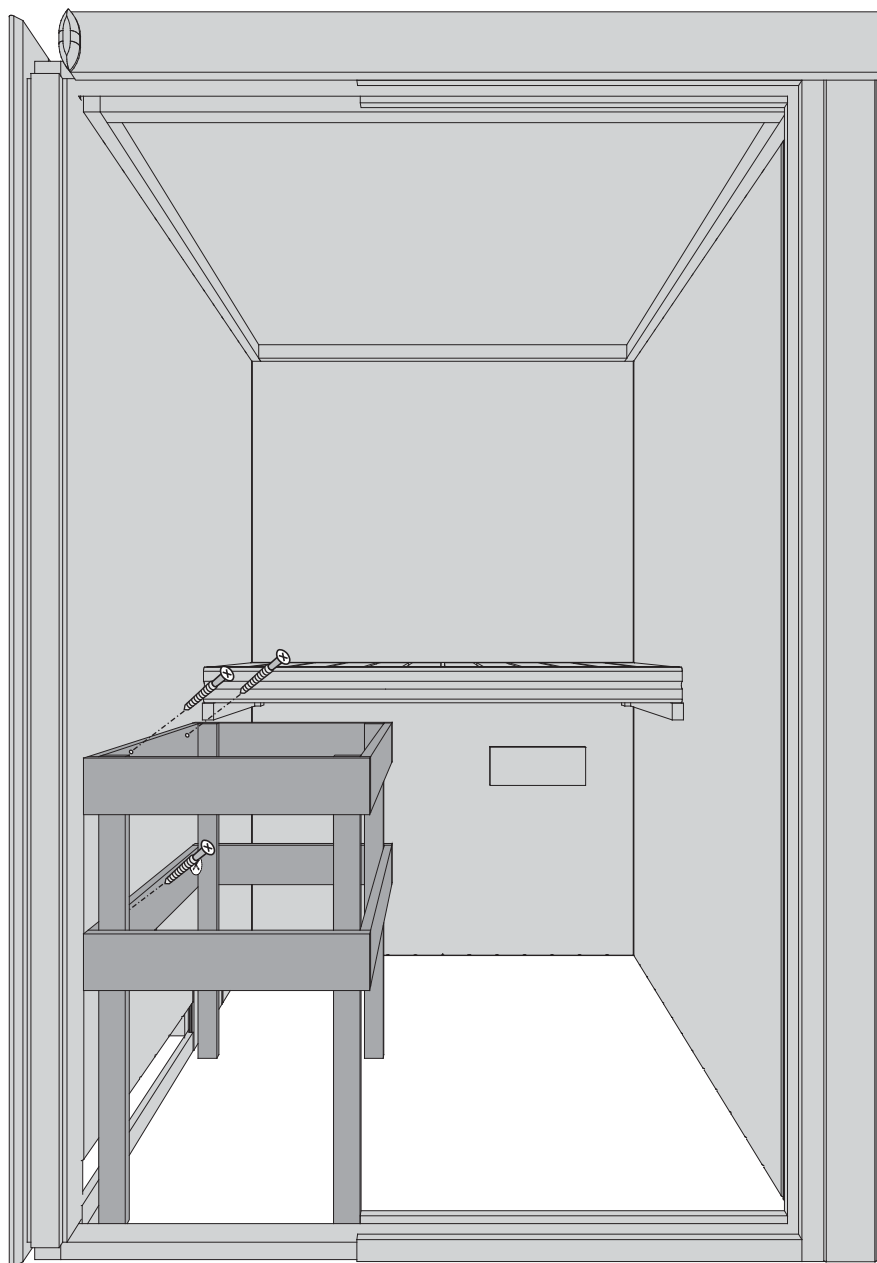
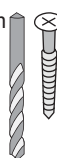

Ø3 mm 4x50

4x



-  Einbau Glastür
-  Montage porte en verre
-  Installation of glass door
-  Montage van de glazen deur
-  Montaje de la puerta de cristal
-  Installazione portello di vetro

**!!! 04 — 08 !!!**