

64623

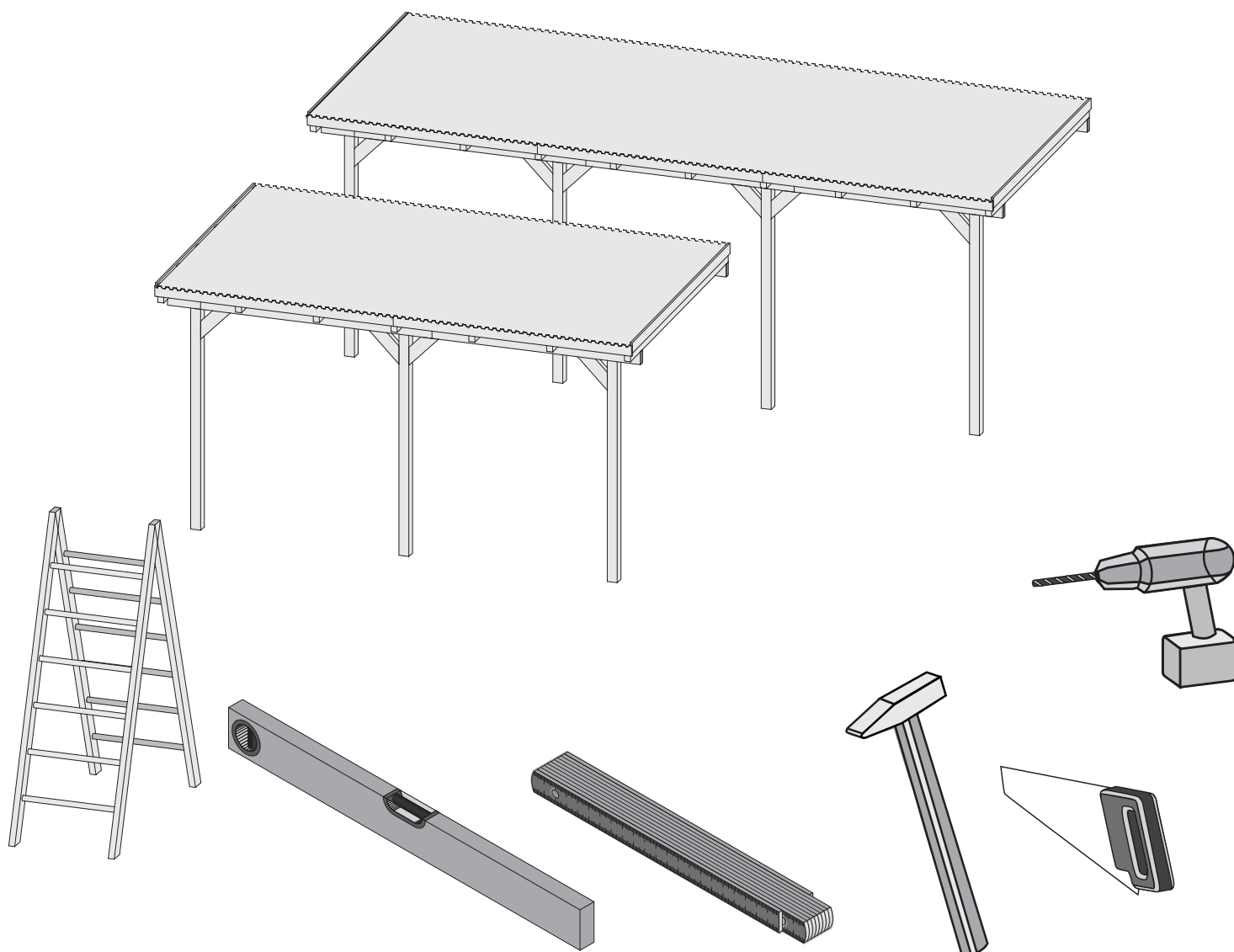

 **Aufbauanleitung**

 **notice de montage**

 **Building Instructions**

 **montagehandleiding**

 **Instrucciones de construcción**

 **Istruzioni per il montaggio**

 **Montážní návod**

 **Service-Hotline: +49 421 38693 33**



Vergleichen Sie zuerst die Materialliste mit Ihrem Paketinhalt! Bitte haben Sie Verständnis, dass Beanstandungen nur im nicht aufgebauten Zustand bearbeitet werden können!



En primer lugar, compare la lista de material con el contenido del paquete. Rogamos entienda que las reclamaciones sólo pueden ser tramitadas antes de montar el objeto!



Nejprve přezkontrolujte obsah balení podle materiálového listu! Mějte pochopení pro to, že případnou reklamaci se můžeme zabývat pouze tehdy, když díly nebudou smontované! Za pomoci tohoto seznamu můžete jednotlivé díly přiřadit k montážnímu návodu.



Vergelijk eerst de lijst van materialen met de inhoud van uw pakket! Reclamaties kunnen alleen in behandeling worden genomen zolang de onderdelen nog niet zijn gemonteerd!



First compare the list of materials with your package contents! Please understand that complaints can be processed in the non-built status only!



Commencez par comparer la liste du matériel avec le contenu de votre paquet! Sachez que nous traitons uniquement les réclamations concernant le matériel à l'état non monté!



Confrontate questa distinta materiali prima con il contenuto del pacchetto! Vi preghiamo di comprendere che eventuali reclami possono essere accolti solo prima del montaggio!

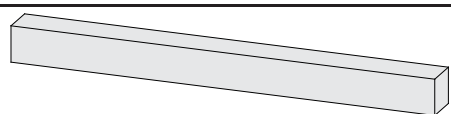
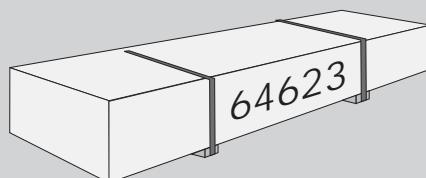

1 x A1a	2350 x 95 x 18mm	ID 39336
6 x A3	2350 x 60 x 40mm	ID 28682
3 x A4	2300 x 115 x 55mm	ID 64756

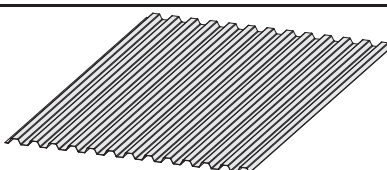

3 x D1	2350 x 900 x 0,8mm	ID 65571
--------	--------------------	----------

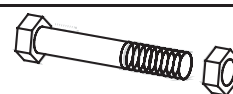

1 x	12 x 120mm	ID 38808
-----	------------	----------

3 x		ID 41060
-----	--	----------

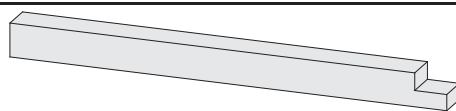

1 x B1	2100 x 90 x 90mm	ID 38800
--------	------------------	----------



100 x	4 x 50mm	ID 3688
4 x	6 x 120mm	ID 9205

6 x		ID 12009
-----	--	----------

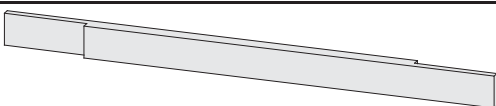
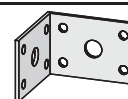

2 x C2	2190 x 155 x 55mm	ID 38797
--------	-------------------	----------

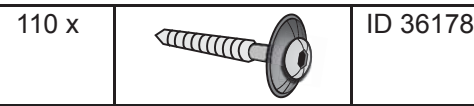

110 x		ID 36178
-------	--	----------

5 x		ID 12011
-----	--	----------

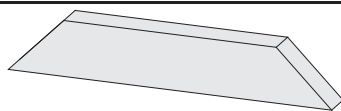

2 x F1	380 x 115 x 55mm	ID 46550
--------	------------------	----------



3 x	12 x 160mm	ID 11750
-----	------------	----------

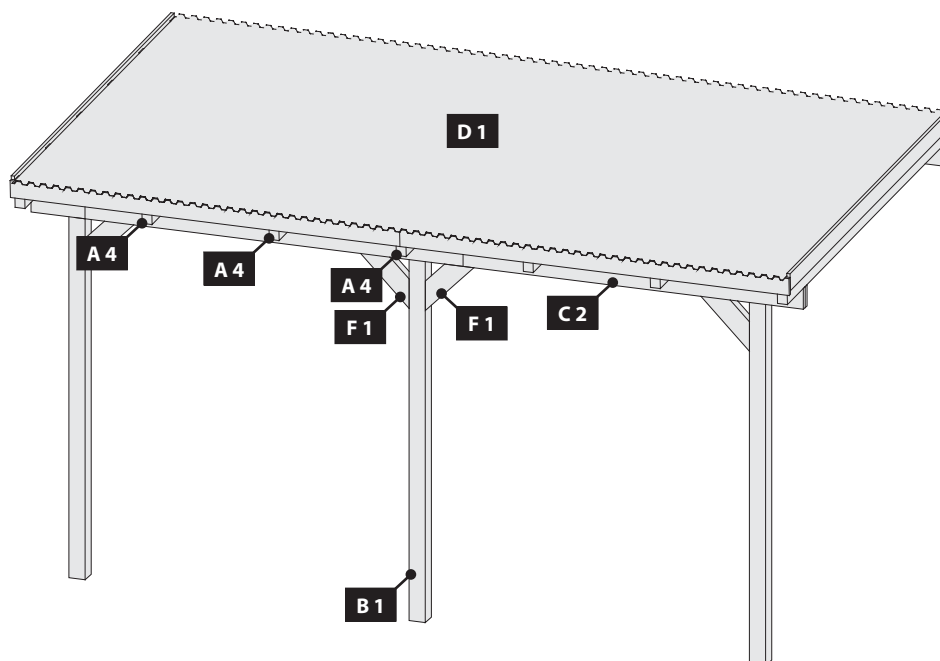

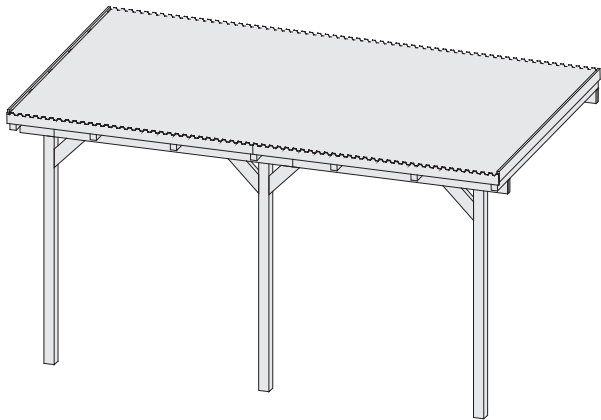

1x

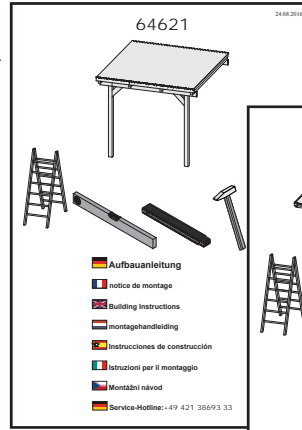

1x



01 → 12

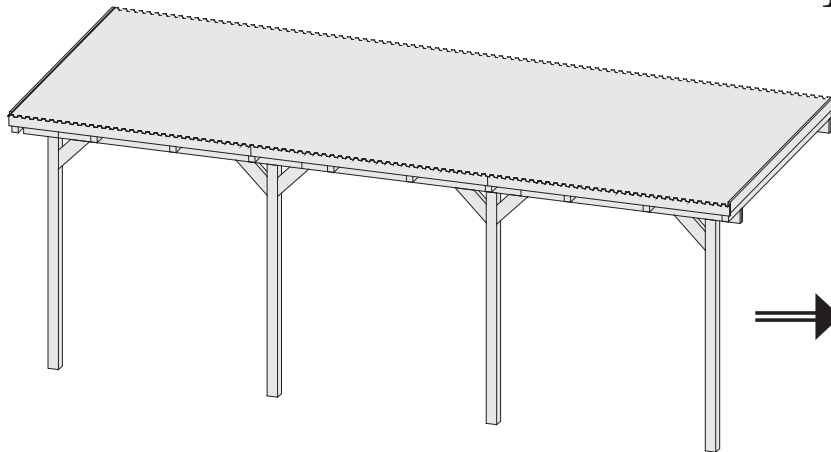

1x

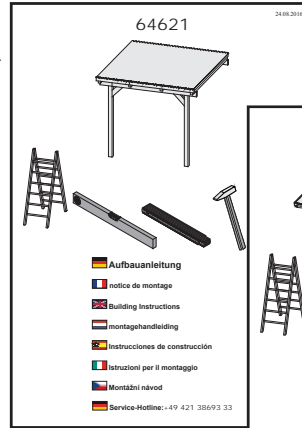

2x



13 → 25

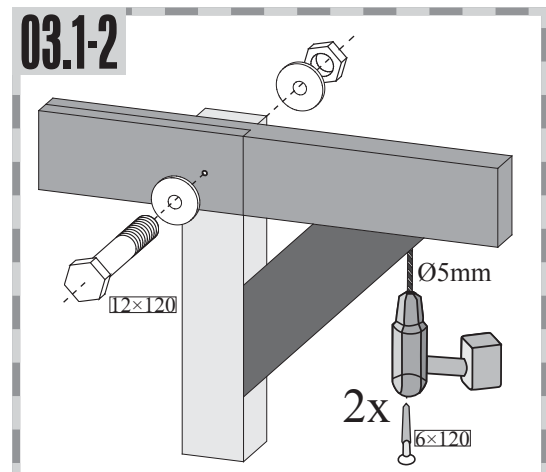
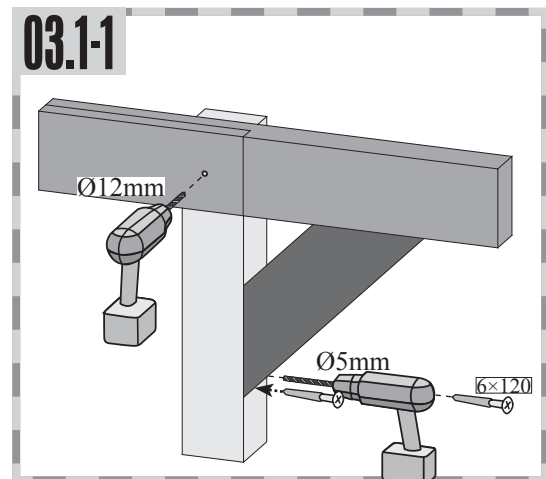
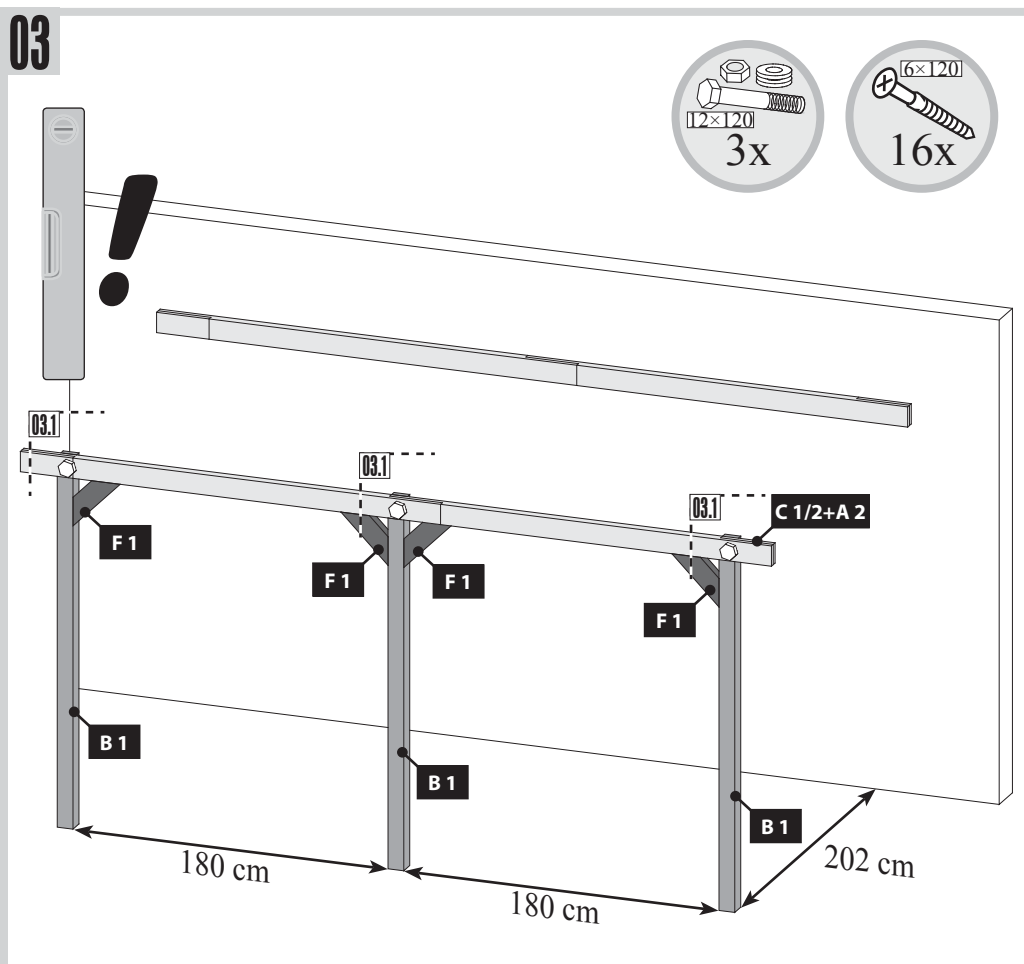
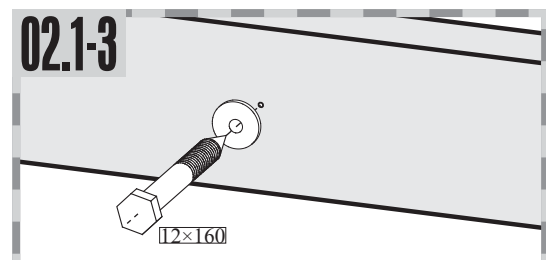
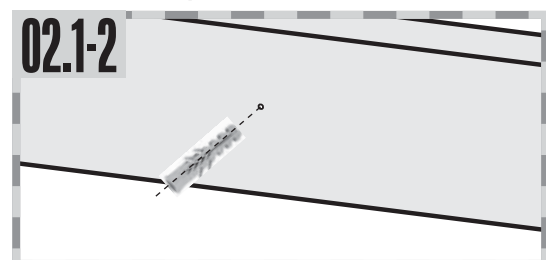
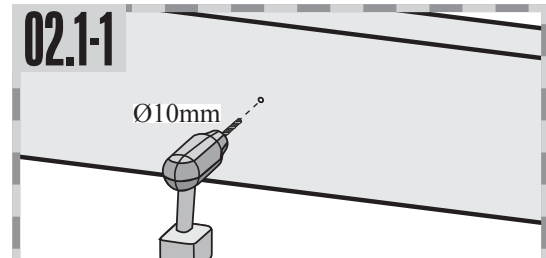
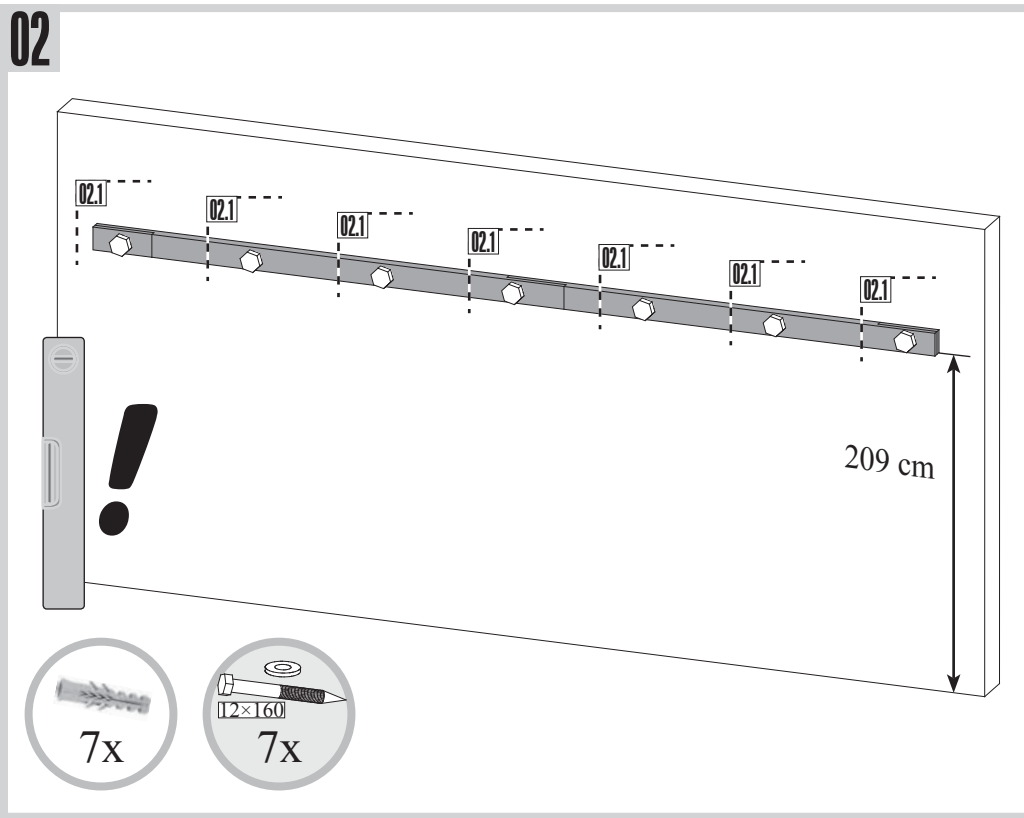
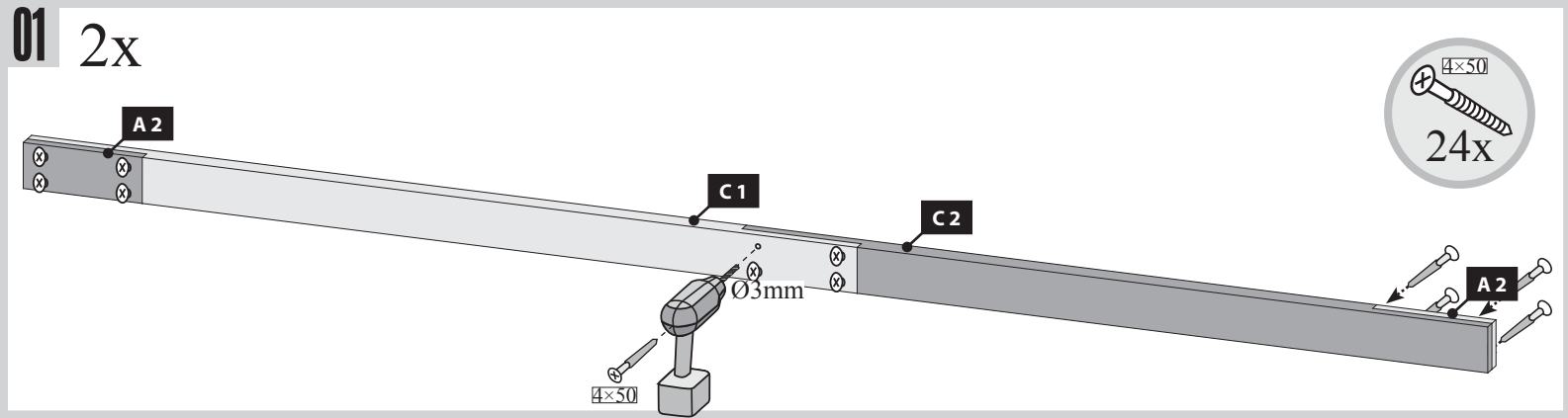

04

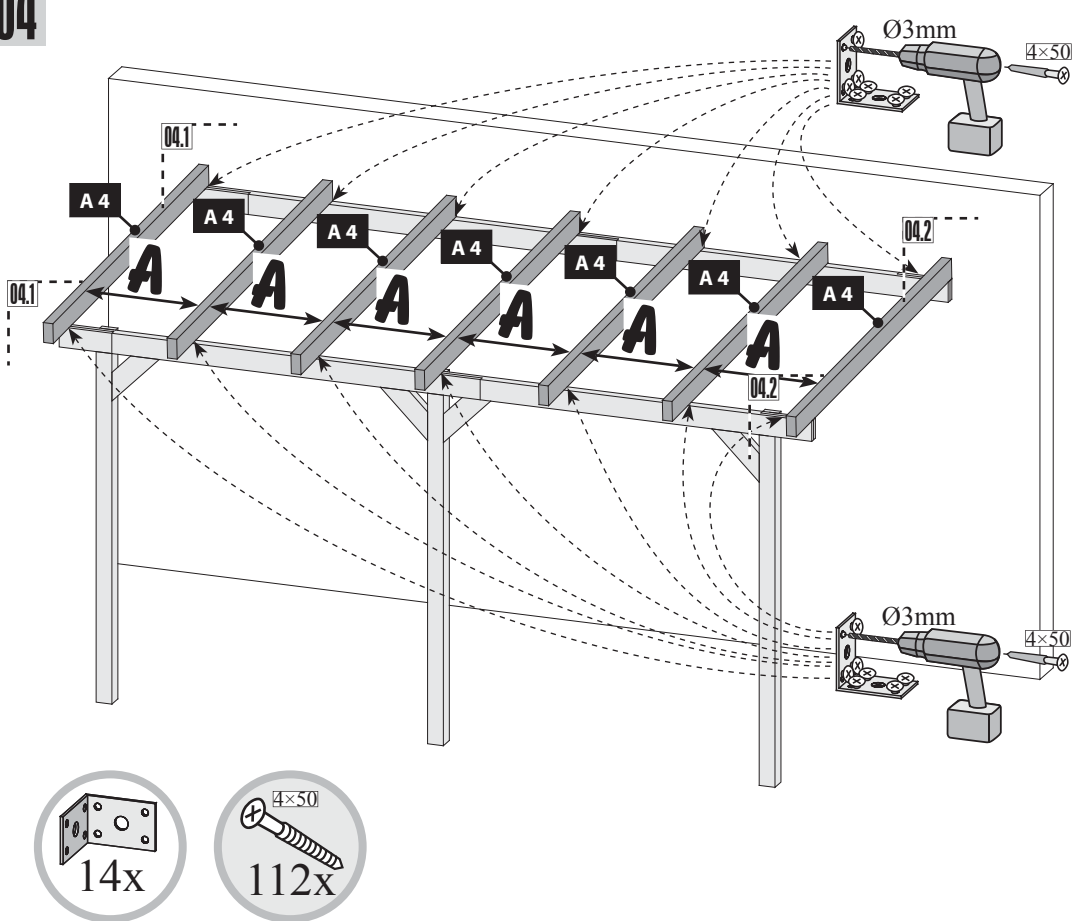

04.1

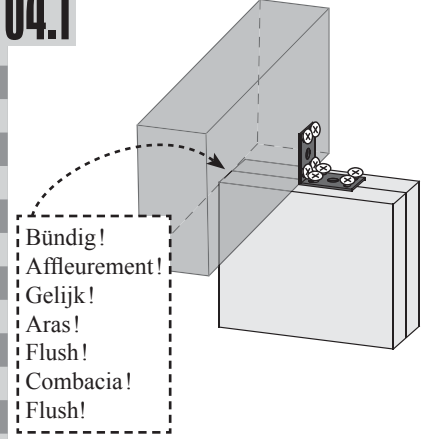

04.2

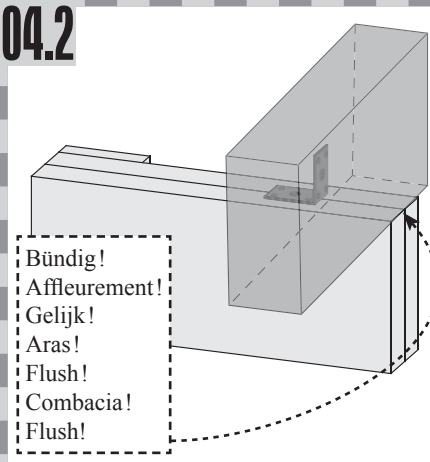

05

12x

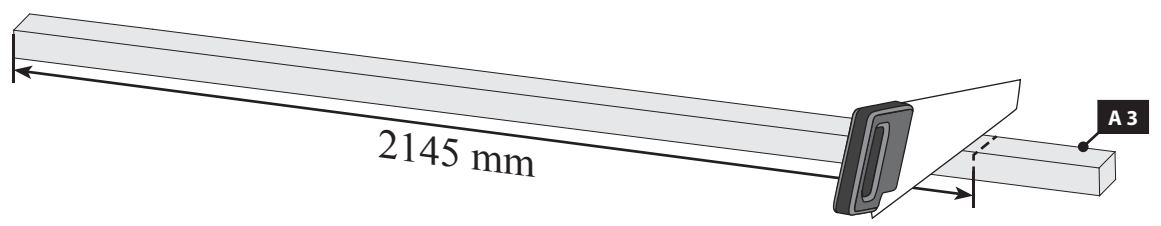

06

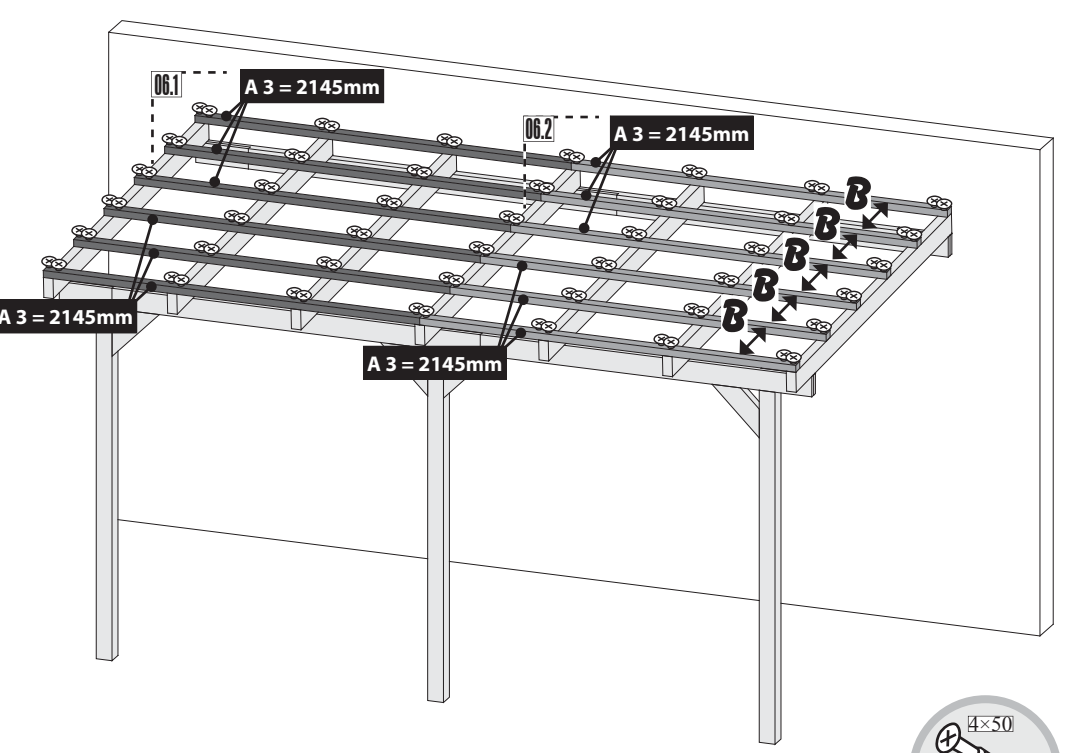

06.1

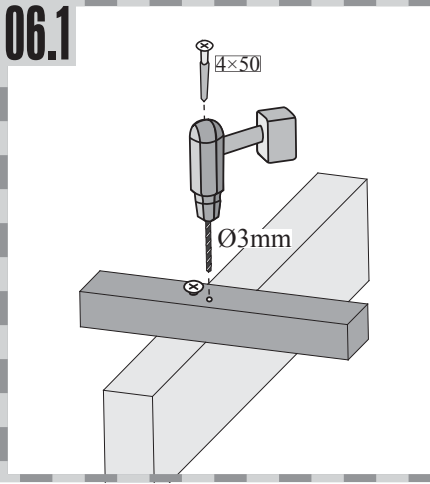

06.2

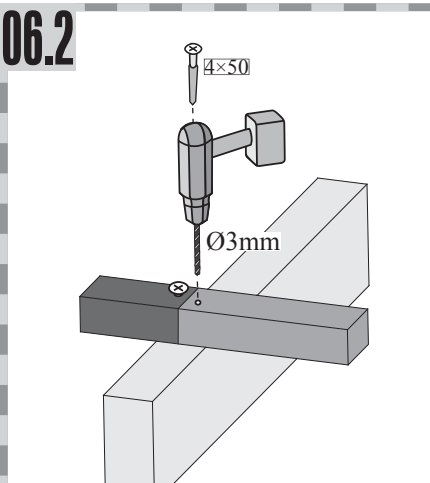

07

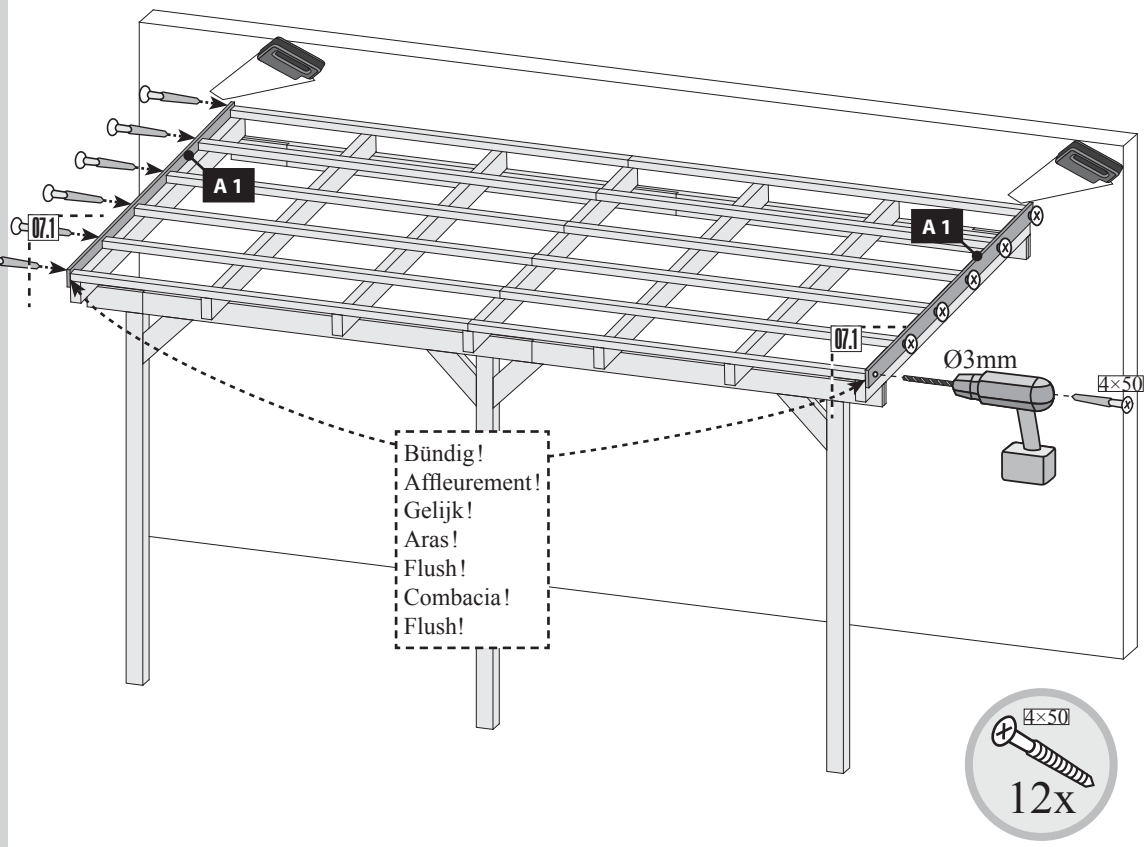

07.1

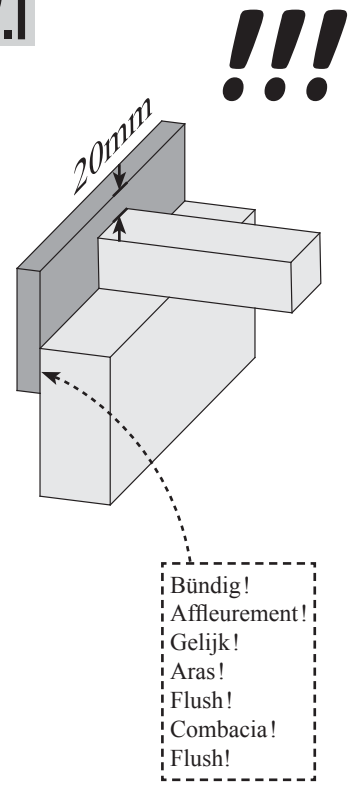

08

1x

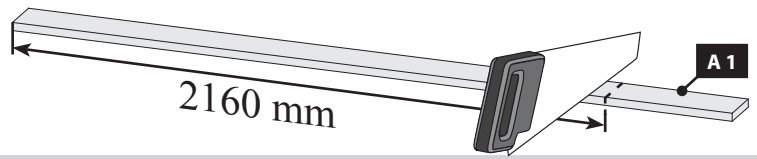

09

1x

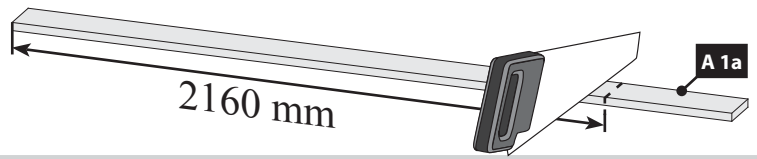

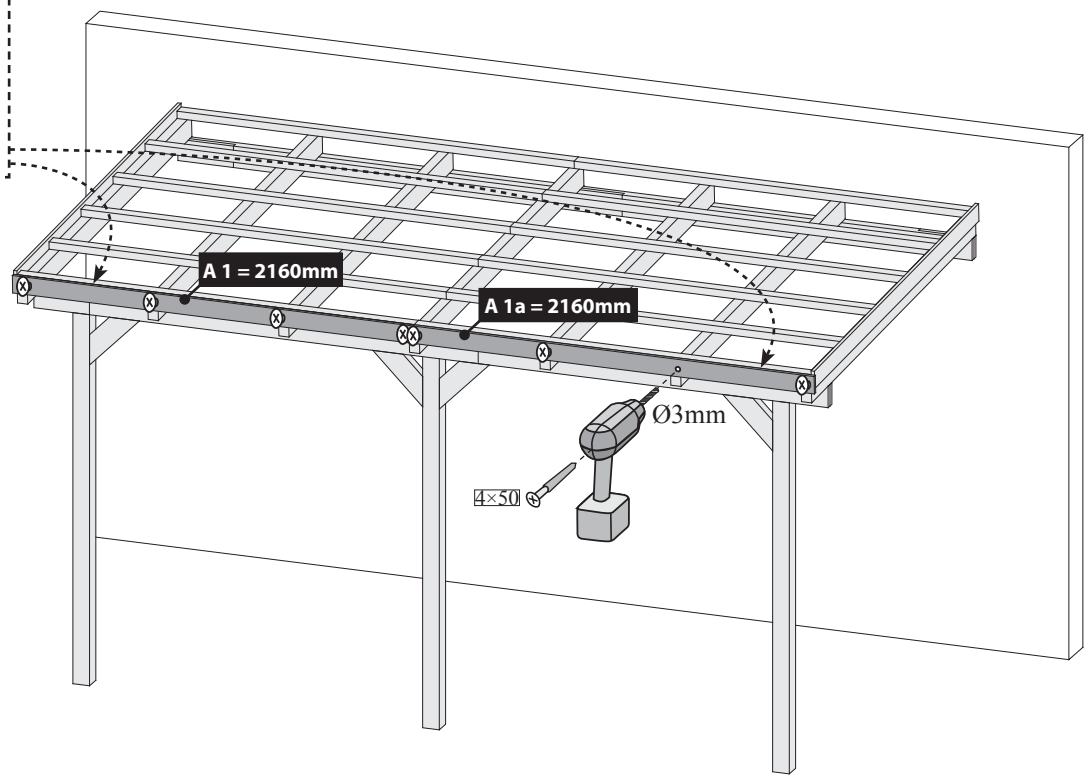

10

Bündig!  
Affleurement!  
Gelijk!  
Aras!  
Flush!  
Combacia!  
Flush!

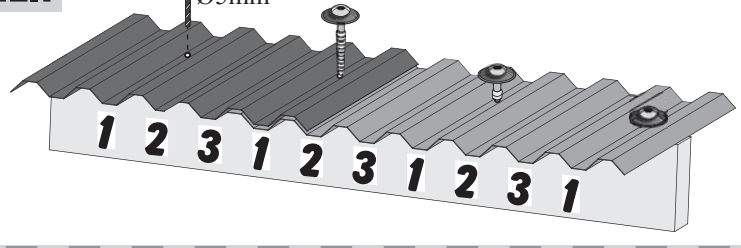
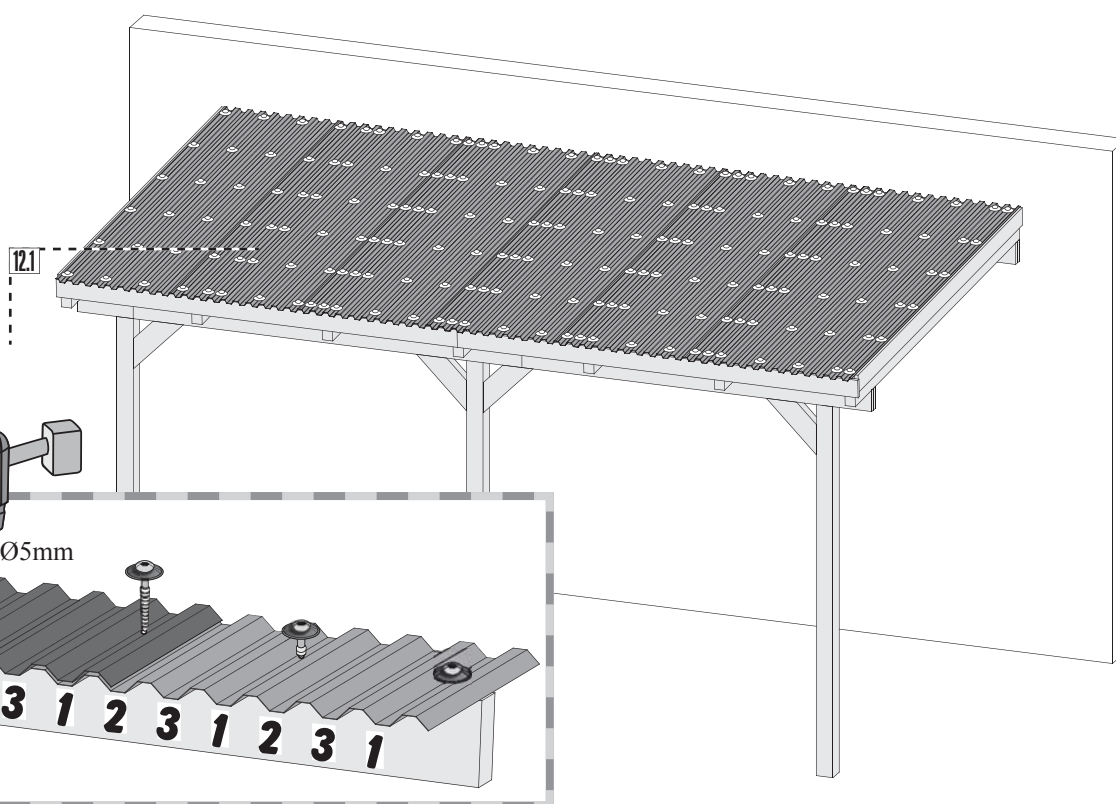
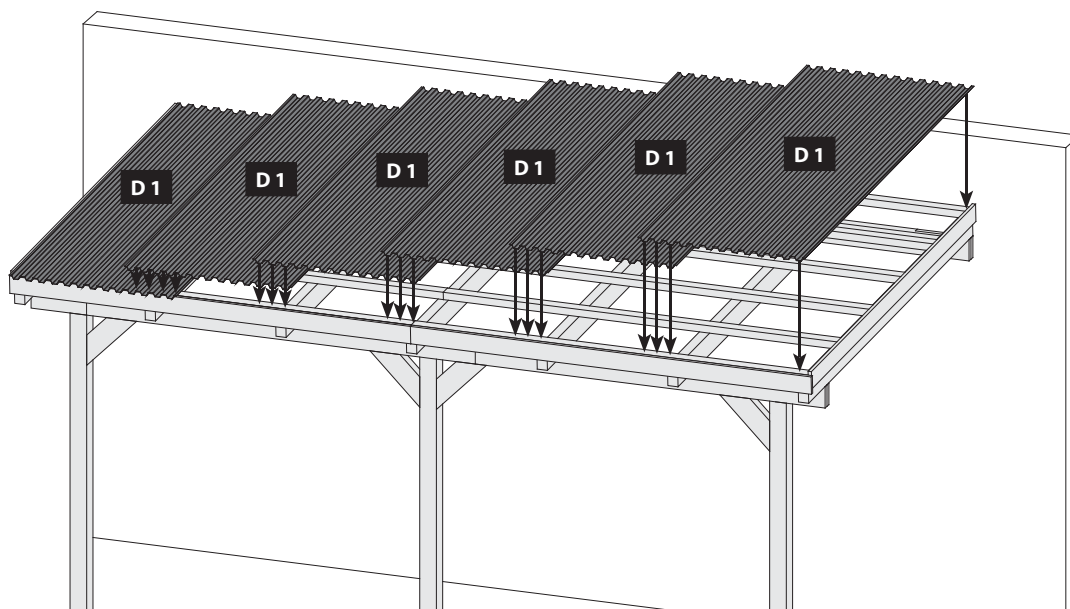





 Die Platten sind in jedem 3. Wellenboden zu verschrauben. In den äußeren Randfeldern jedoch in jedem Wellenboden sowie in der Überlappung. Schrauben Sie bis die Gummidichtung fest an der Platte liegt. Die Löcher in den Dachplatten werden in der Mitte der Welle mit einem Holzbohrer gebohrt. Bitte beachten Sie, dass das Bohrfutter die Dachplatte nicht beschädigt. Die Schrauben müssen rechtwinklig in die Latten montiert werden.

 Visser les plaques sur toutes les 3 planches ondulées. Aux extrémités, visser chaque planche ondulée ainsi que le chevauchement. Vissez jusqu'à ce que la rondelle de caoutchouc soit solidement fixée à la plaque. Percer les trous des plaques de toit dans le milieu de l'ondulation avec une mèche spéciale bois. Veillez à ce que le mandrin n'abîme pas la plaque de toit. Les vis doivent être fixées à angle droit dans les lattes.

 Screw down the plates in every third corrugated base, however at the outer edges in every corrugated base and in the overlapping. Tighten the screws until the rubber seal lies firmly on the plate. Drill the holes in the roof plates in the centre of the corrugation with a special wood drill. Please note that the drill chuck does not damage the roof plate. The screws must be driven vertically into the lath sections.

 De platen dienen in elk 3e dal van de golfplaat te worden vastgeschroefd. In de buitenste randvlakken echter in ieder dal van de golfplaat alsmede in de overlapping vastschroeven. Schroef vast totdat de rubberafdichting stevig tegen de plaat aanligt. De gaten in de dakplaten worden in het midden van de golf met een speciaal houtboortje geboord. Let er a.u.b. op, dat de boorhouder de dakplaat niet beschadigt. De schroeven moeten haaks in de latten worden gemonteerd.

 Atornillar los tableros en cada tercera base ondulada. En los campos de bordes exteriores hay que atornillar en cada base ondulada y en el solapamiento. Atornille hasta que la junta de goma se encuentre fija junto al tablero. Los agujeros de los tableros del techo se taladran en el centro con una taladradora especial para madera. Cerciórese que el portabrocas no dañe el tablero del techo. Montar los tornillos en ángulo recto en los listones.

 I pannelli devono essere fissati in ogni 3 inferiore onda. Nei campi bordo esterno ma in ogni terra albero e nella sovrapposizione. Vite è la guarnizione di gomma alla piastra. I fori dei pannelli di copertura sono perforati nel centro dell'albero con un legno speciale trapano. Si prega di notare che il mandrino non danneggiare il pannello del tetto. Le viti devono essere installati perpendicolarmente ai listelli.

 Panely jsou k upevnění v každém 3. spodní vlny. Ve vnějších oblastech hran, ale v každém hřídele zemi a v překrytí. Šroub je na pryžové těsnění k desce. Otvory v střešních panelů jsou vyvrtány ve středu hřídele se zvláštním vrtací dřeva. Upozorňujeme, že sklíčidlo nepoškodí střešní panel. Šrouby musí být instalován kolmo na latě.

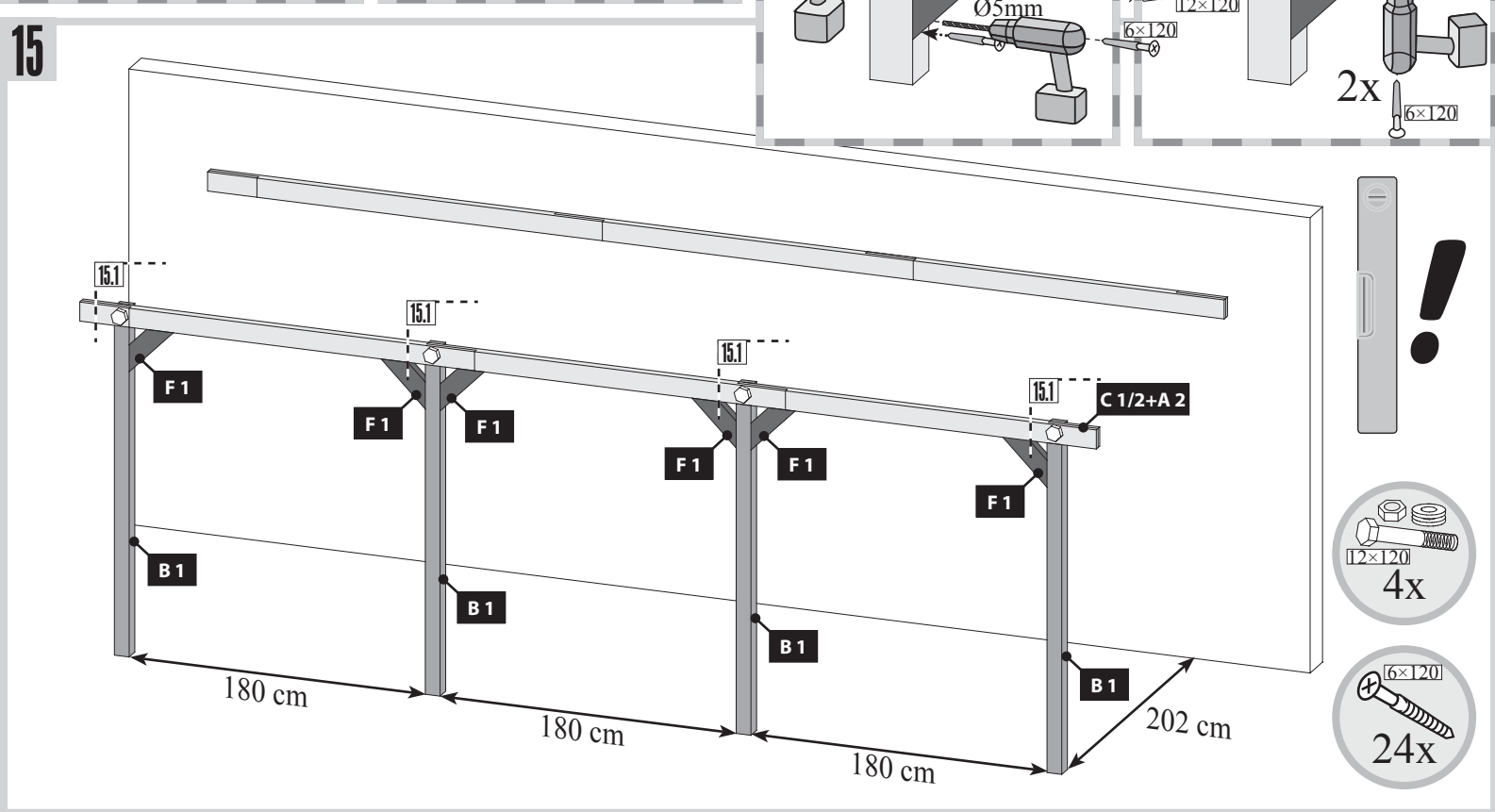
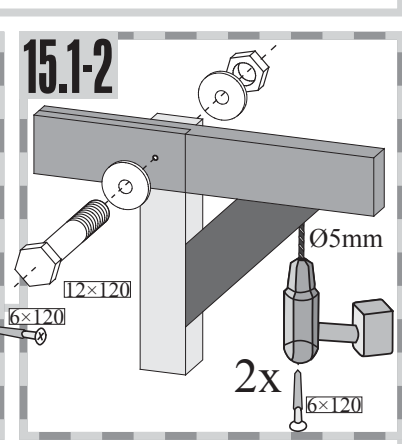
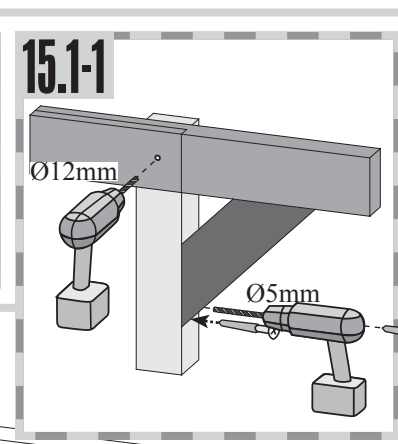
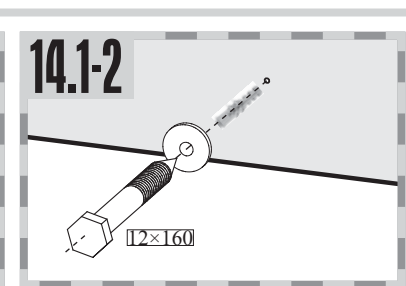
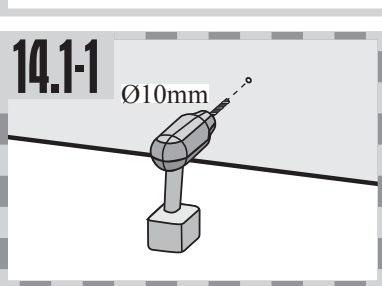
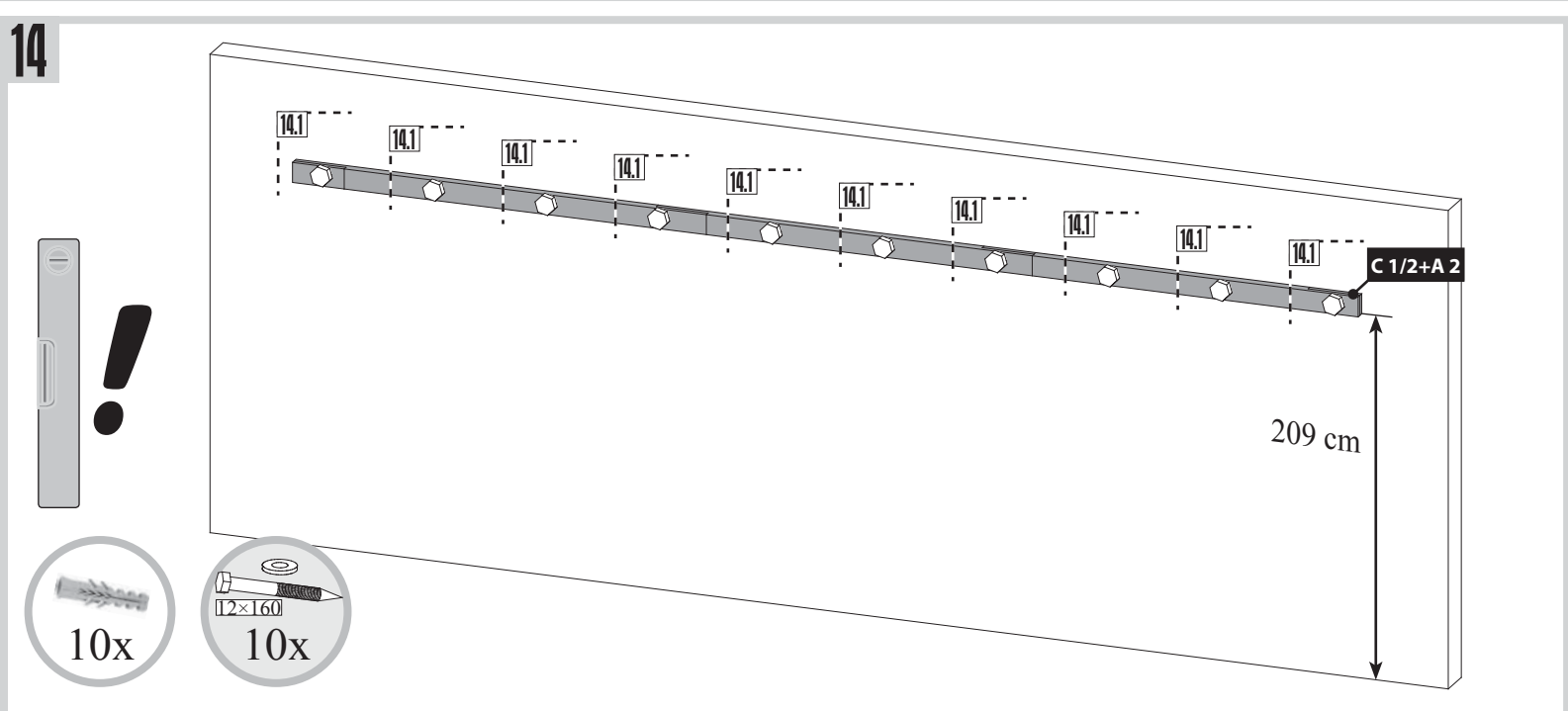
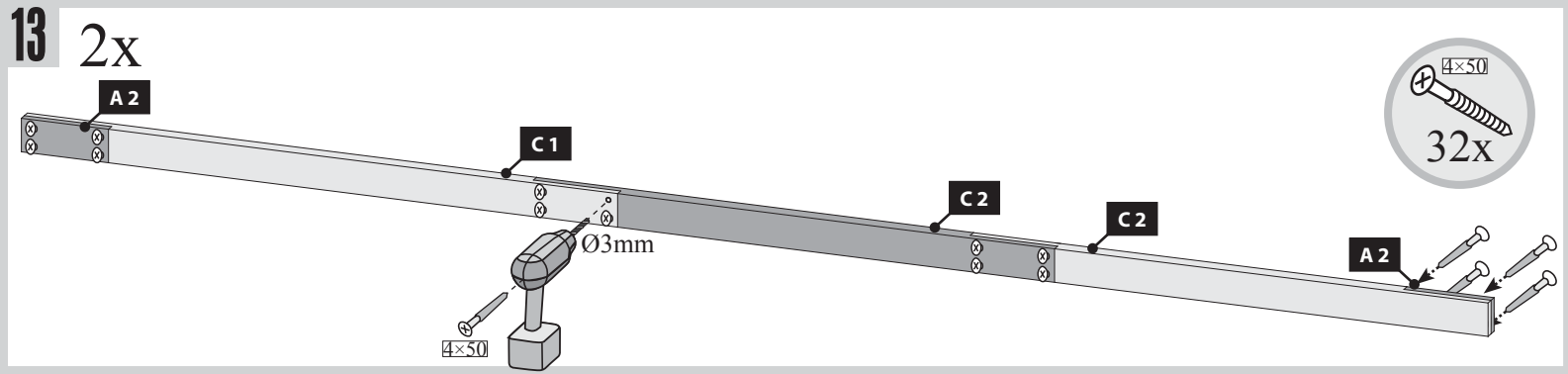



16

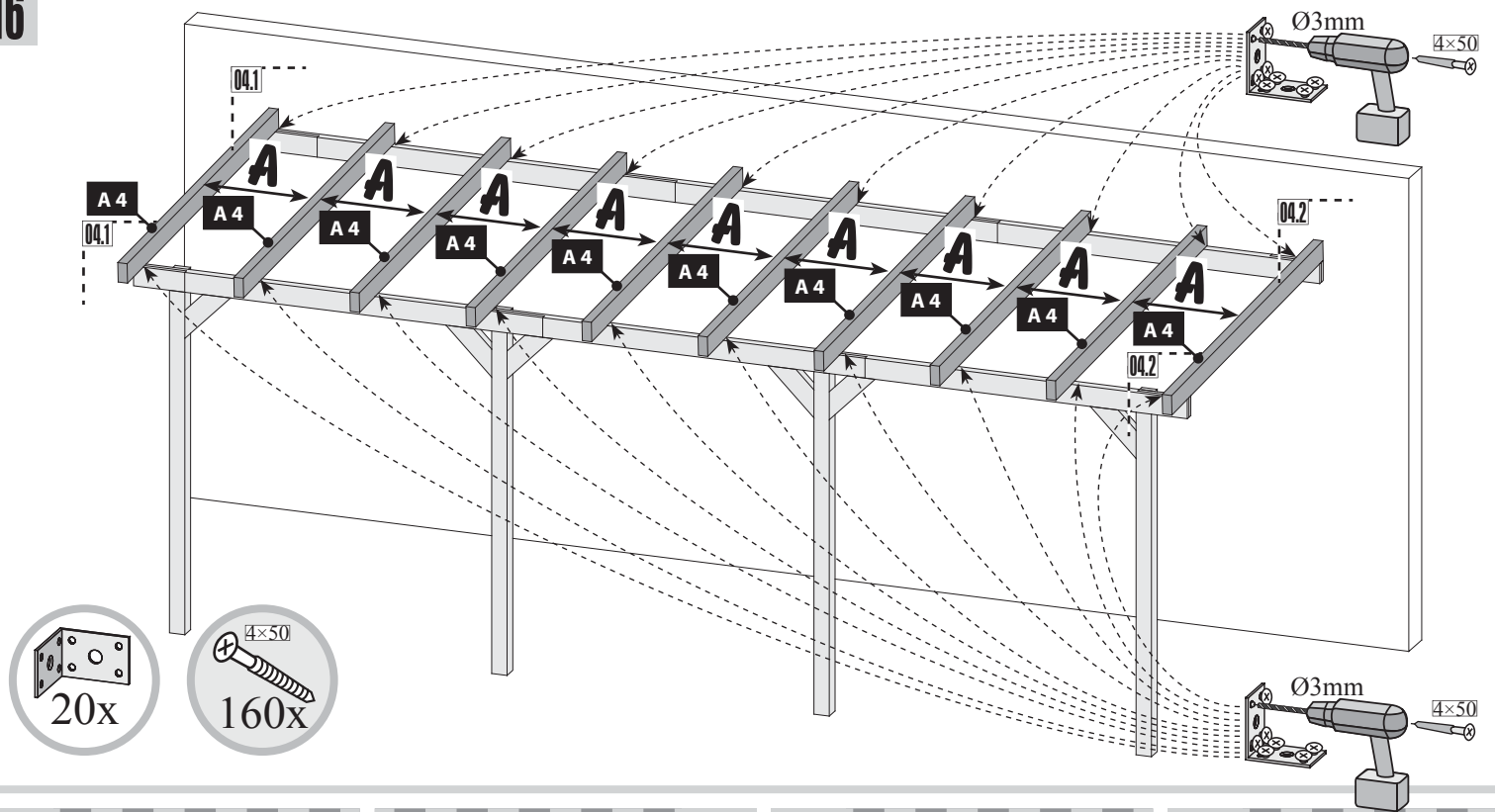

16.1

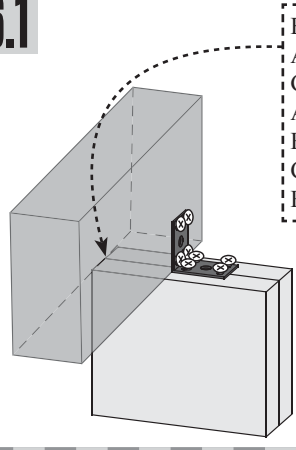

Bündig!  
Affleurement!  
Gelijk!  
Aras!  
Flush!  
Combacia!  
Flush!

16.2

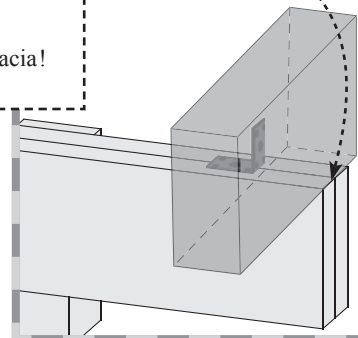

19.1

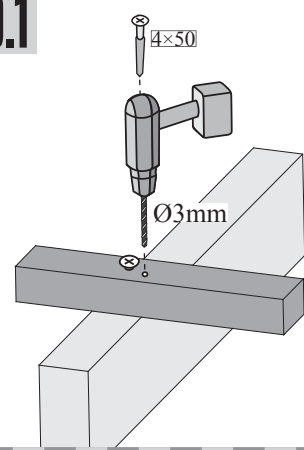

19.2

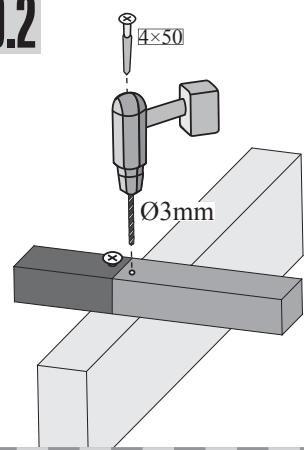

17

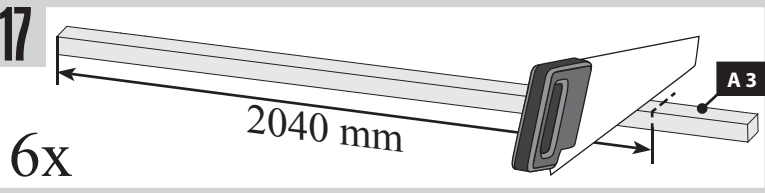

18

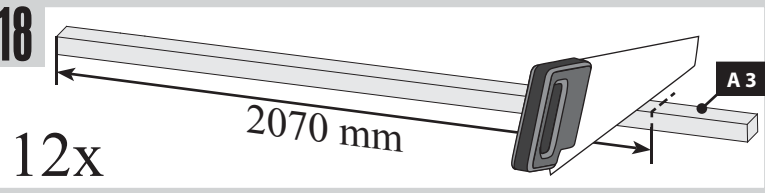

19

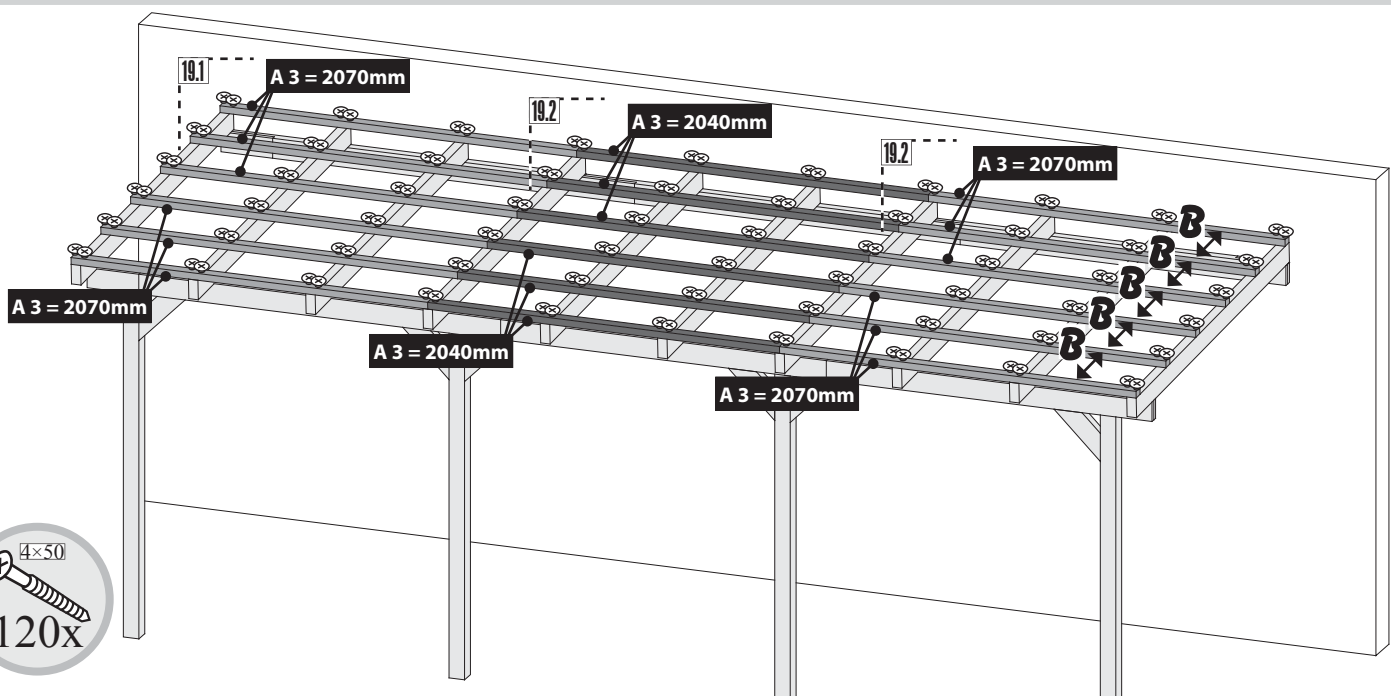

20

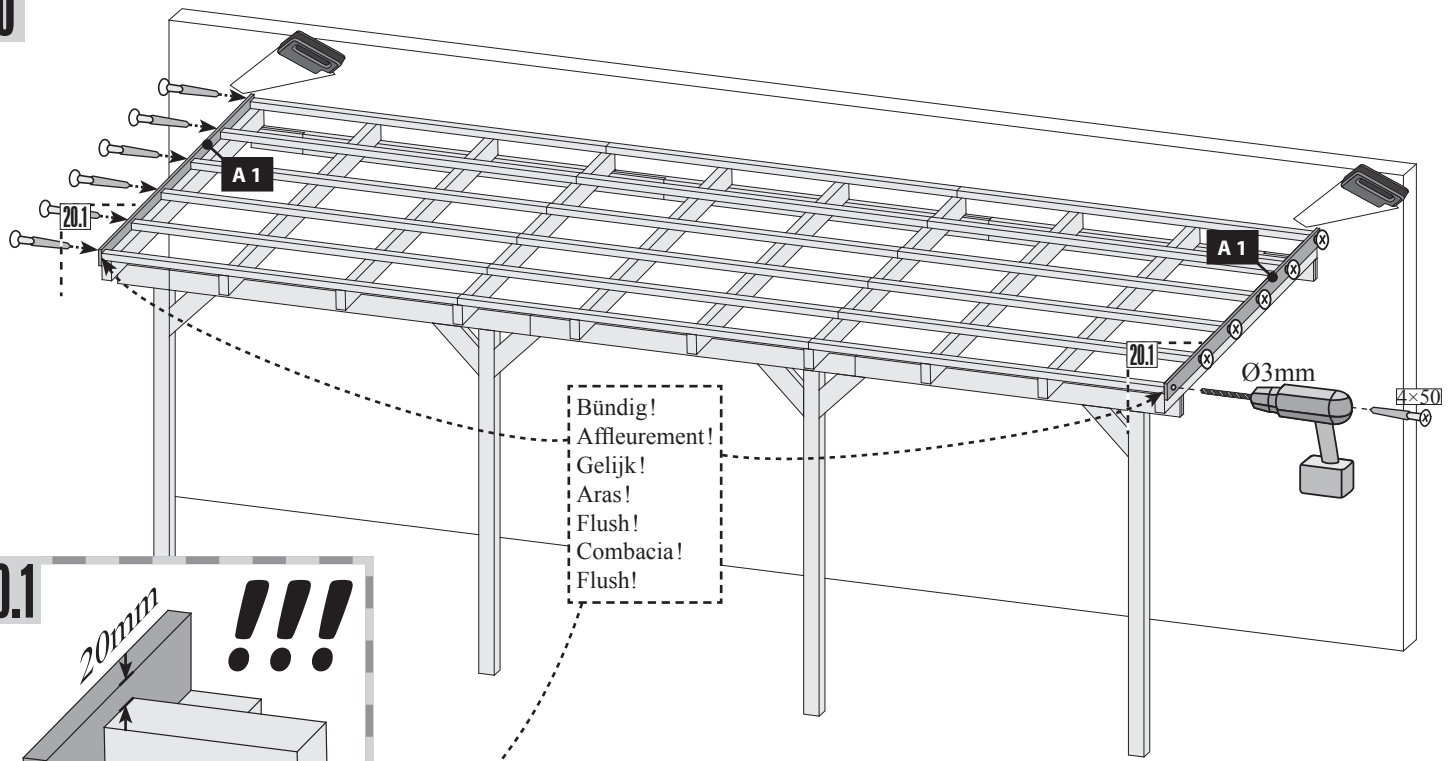

20.1

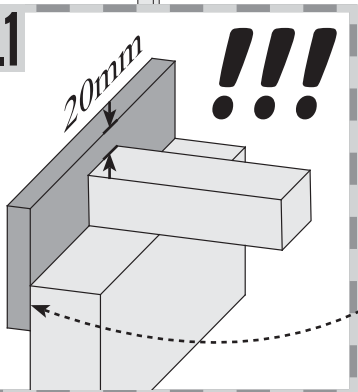

21 1x

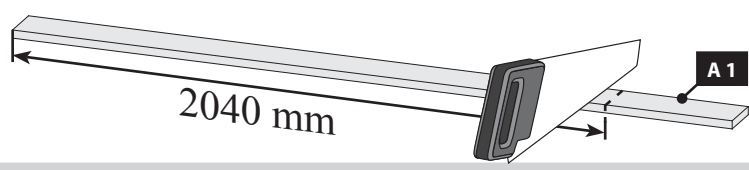

22 2x

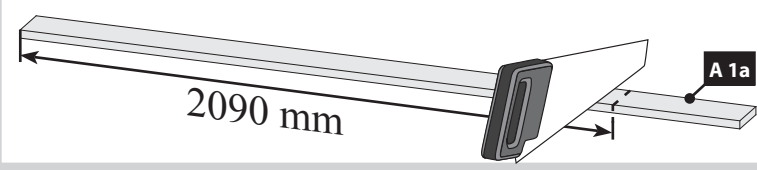

23

Bündig!  
Affleurement!  
Gelijk!  
Aras!  
Flush!  
Combacia!  
Flush!

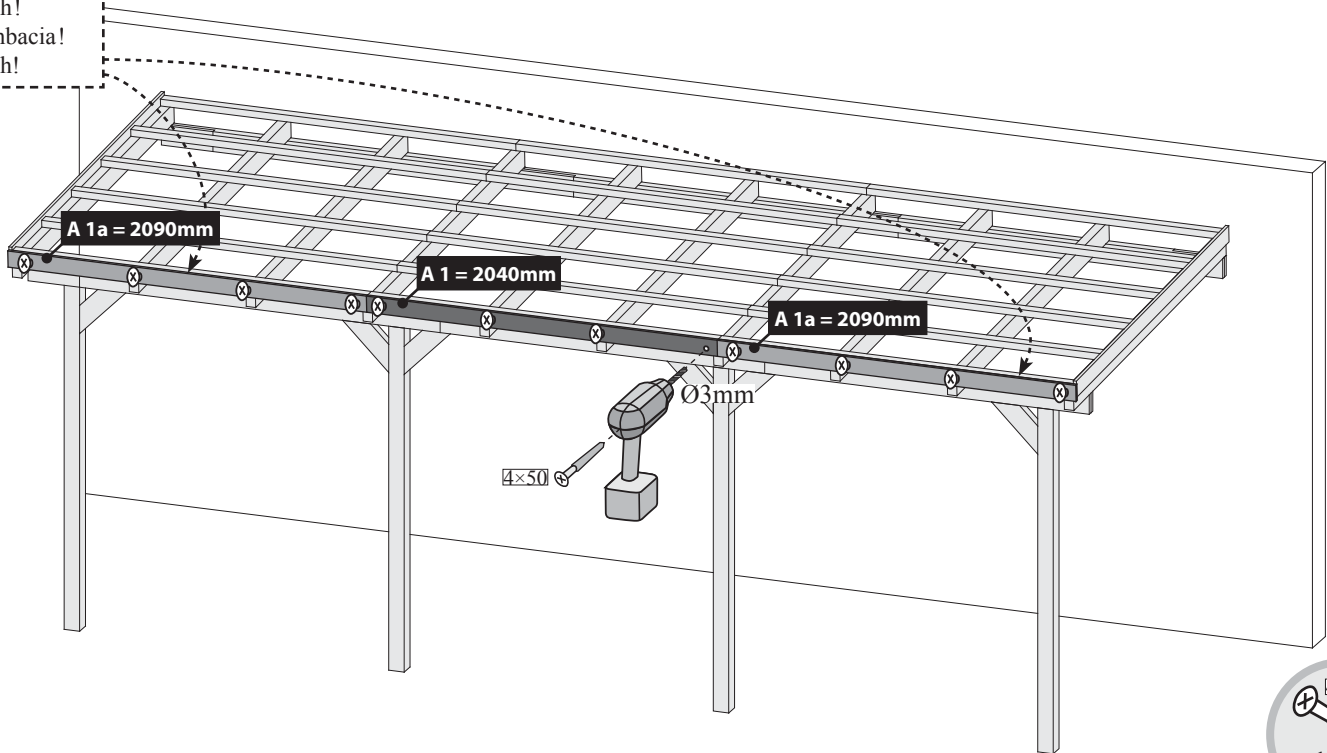

24

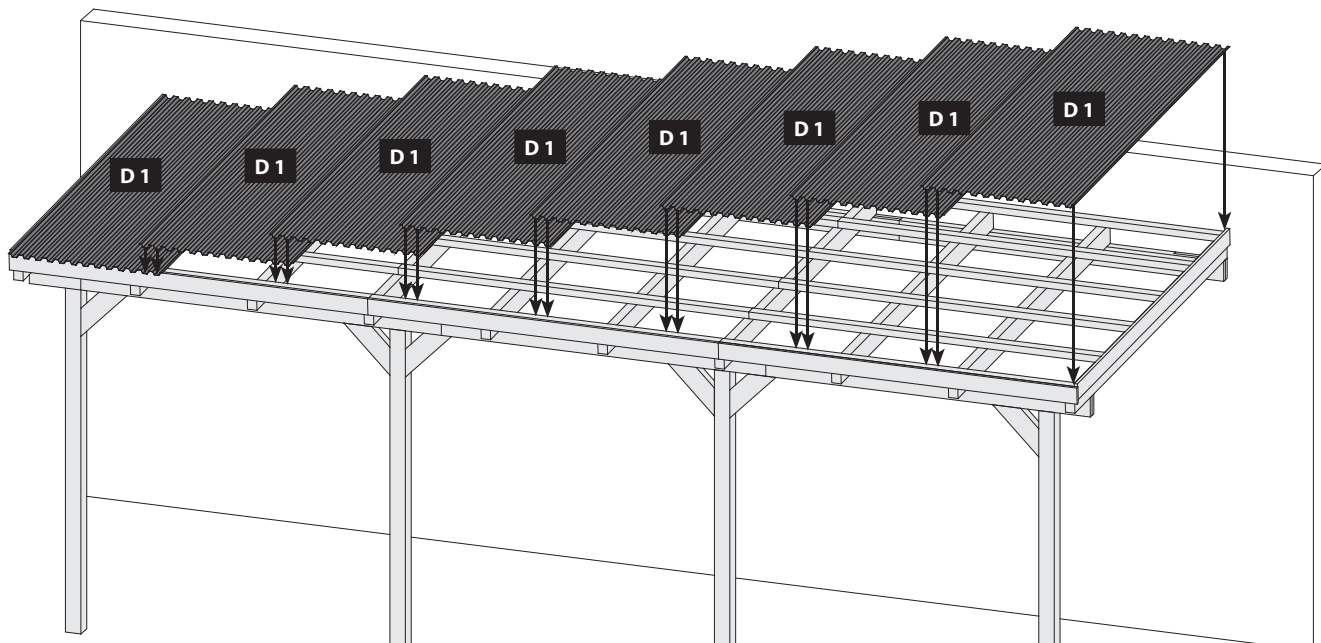

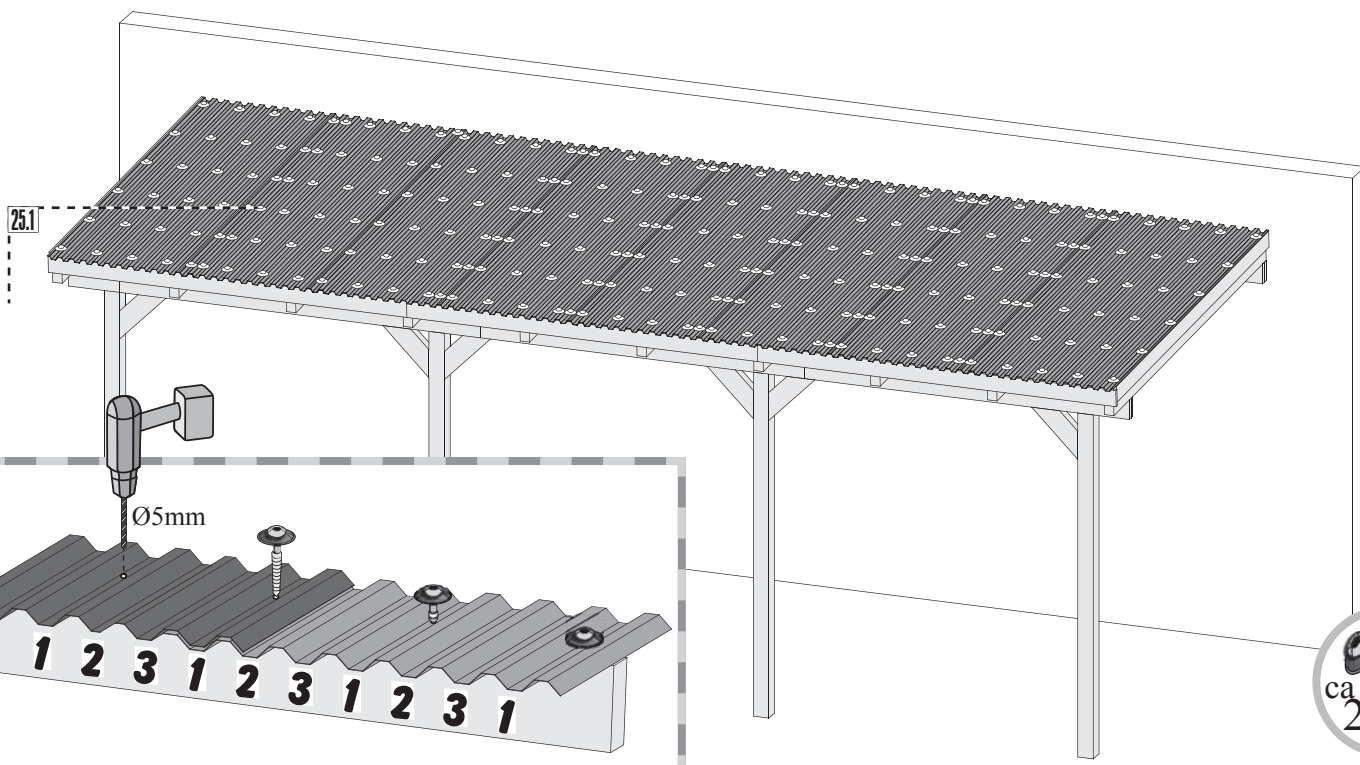

25



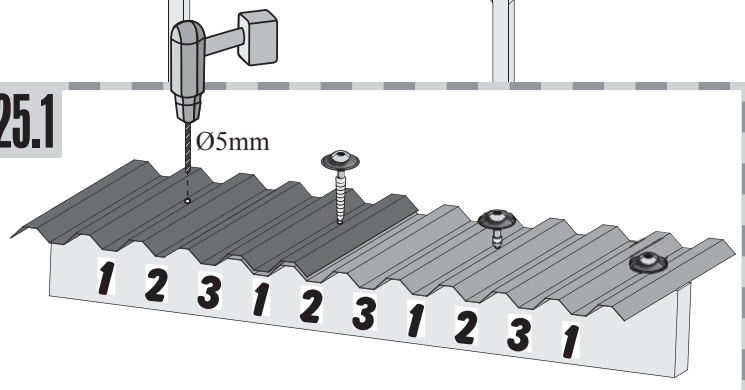

25.1





 Die Platten sind in jedem 3. Wellenboden zu verschrauben. In den äußeren Randfeldern jedoch in jedem Wellenboden sowie in der Überlappung. Schrauben Sie bis die Gummidichtung fest an der Platte liegt. Die Löcher in den Dachplatten werden in der Mitte der Welle mit einem Holzbohrer gebohrt. Bitte beachten Sie, dass das Bohrfutter die Dachplatte nicht beschädigt. Die Schrauben müssen rechtwinklig in die Latten montiert werden.

 Visser les plaques sur toutes les 3 planches ondulées. Aux extrémités, visser chaque planche ondulée ainsi que le chevauchement. Vissez jusqu'à ce que la rondelle de caoutchouc soit solidement fixée à la plaque. Percer les trous des plaques de toit dans le milieu de l'ondulation avec une mèche spéciale bois. Veillez à ce que le mandrin n'abîme pas la plaque de toit. Les vis doivent être fixées à angle droit dans les lattes.

 Screw down the plates in every third corrugated base, however at the outer edges in every corrugated base and in the overlapping. Tighten the screws until the rubber seal lies firmly on the plate. Drill the holes in the roof plates in the centre of the corrugation with a special wood drill. Please note that the drill chuck does not damage the roof plate. The screws must be driven vertically into the lath sections.

 De platen dienen in elk 3e dal van de golfplaat te worden vastgeschroefd. In de buitenste randvlakken echter in ieder dal van de golfplaat alsmede in de overlapping vastschroeven. Schroef vast totdat de rubberafdichting stevig tegen de plaat aanligt. De gaten in de dakplaten worden in het midden van de golf met een speciaal houtboortje geboord. Let er a.u.b. op, dat de boorhouder de dakplaat niet beschadigt. De schroeven moeten haaks in de latten worden gemonteerd.

 Atornillar los tableros en cada tercera base ondulada. En los campos de bordes exteriores hay que atornillar en cada base ondulada y en el solapamiento. Atornille hasta que la junta de goma se encuentre fija junto al tablero. Los agujeros de los tableros del techo se taladrarán en el centro con una taladradora especial para madera. Cerciórese que el portabrocas no dañe el tablero del techo. Montar los tornillos en ángulo recto en los listones.

 I pannelli devono essere fissati in ogni 3 inferiore onda. Nei campi bordo esterno ma in ogni terra albero e nella sovrapposizione. Vite è la guarnizione di gomma alla piastra. I fori dei pannelli di copertura sono perforati nel centro dell'albero con un legno speciale trapano. Si prega di notare che il mandrino non danneggiare il pannello del tetto. Le viti devono essere installati perpendicolarmente ai listelli.

 Panely jsou k upevnění v každém 3. spodní vlny. Ve vnějších oblastech hran, ale v každém hřídele zemi a v překrytí. Šroub je na pryžové těsnění k desce. Otvory v střešních panelů jsou vyvrtány ve středu hřídele se zvláštním vrtací dřeva. Upozorňujeme, že sklíčidlo nepoškodí střešní panel. Šrouby musí být instalován kolmo na latě.

## **Lagerung**

*Prüfen Sie genau Ihre gelieferte Ware, spätere Reklamationen können nicht anerkannt werden.*

*Bitte beachten Sie diese Lagerungs- und Verarbeitungshinweise. Bei Nichteinhalten keine Reklamationsansprüche!*

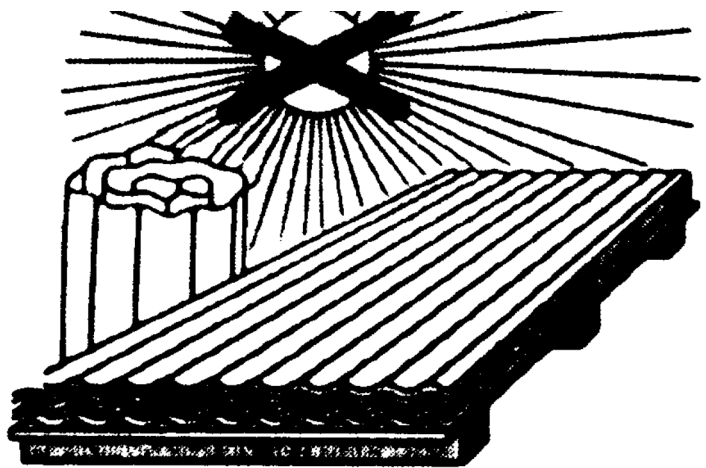

- Hitzestau und Nässe vermeiden.
- PVC-Tafeln dürfen im Stapel nicht dem Sonnenlicht und der Feuchtigkeit ausgesetzt werden. Es besteht Gefahr der Überhitzung (Brennglaswirkung!).
- Die maximale Lagerungstemperatur im Stapel darf 60°C nicht überschreiten. Für Brennglasschäden übernehmen wir keine Haftung.
- Auf ebener, nicht aufgeheizter Unterlage lagern und mit licht- und wasserundurchlässigen hellen Planen abdecken.
- Stapelhöhe max 50 cm
- Max Raumtemperatur: 40°C
- Während der Lagerung müssen PVC-Tafeln von Witterungseinflüssen, Verschmutzung und mechanischen Belastungen geschützt werden.

## **Montage**

- Nicht bei Temperaturen unter 5°C durchführen.
- Montagebedingte manuelle Transporte einzelner Platten nicht bei Windgeschwindigkeit über 3m/s durchführen.

## **Reinigung**

- Der Reinigungszyklus ist abhängig vom Verschmutzungsgrad, sollte jedoch von außen mindestens einmal jährlich erfolgen.
- Verschmutzungen mit Wasser oder Haushaltsreinigungsmitteln beseitigen.
- Keine scheuernden, ätzenden oder lösungsmittelhaltigen Zusätze verwenden.