

# 60787

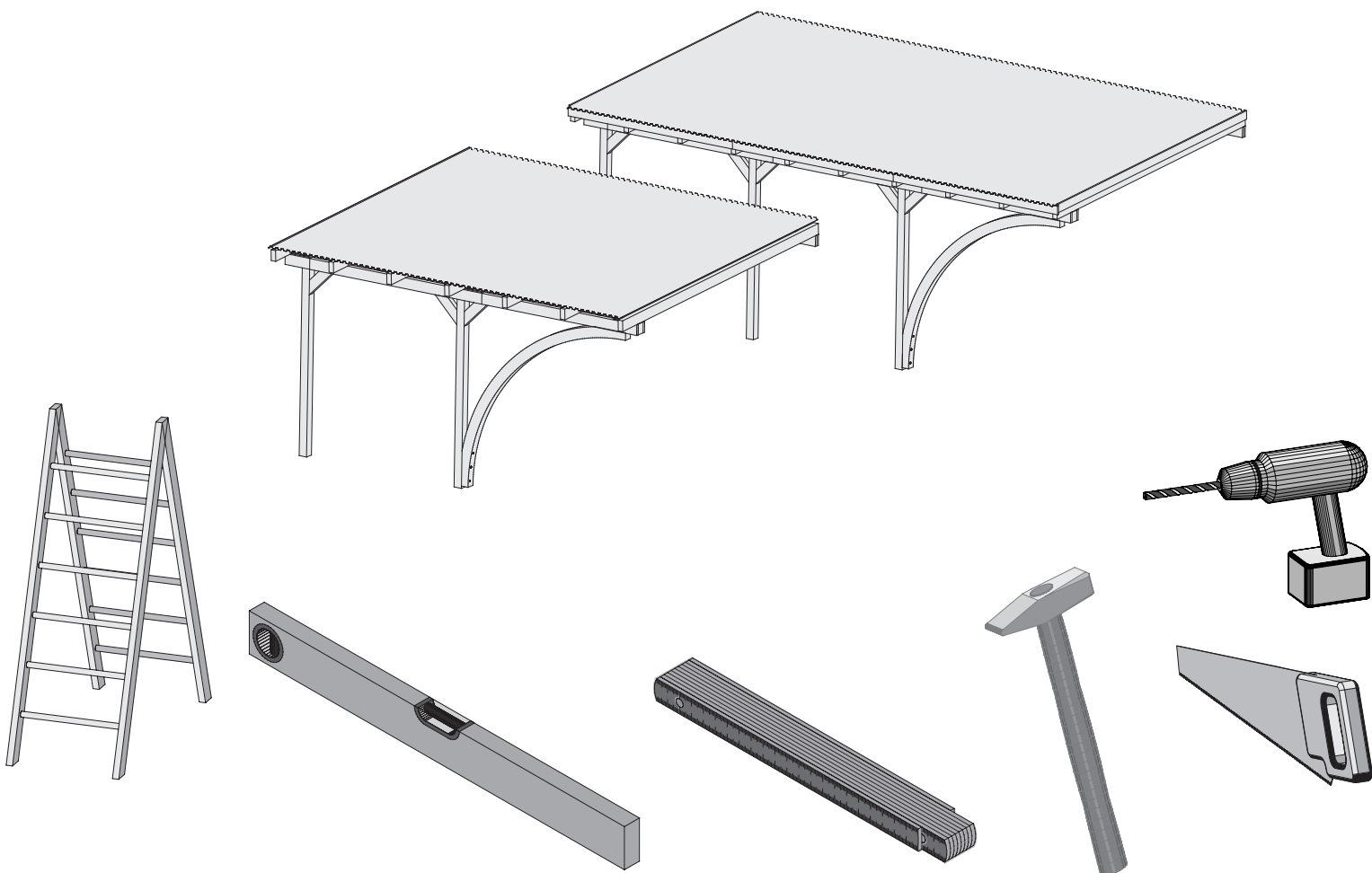

 **Aufbauanleitung**

 **notice de montage**

 **Building Instructions**

 **montagehandleiding**

 **Instrucciones de construcción**

 **Istruzioni per il montaggio**

 **Service-Hotline: +49 421 38693 33**



Vergleichen Sie zuerst die Materialliste mit Ihrem Paketinhalt! Bitte haben Sie Verständnis, dass Beanstandungen nur im nicht aufgebauten Zustand bearbeitet werden können!



Commencez par comparer la liste du matériel avec le contenu de votre paquet! Sachez que nous traitons uniquement les réclamations concernant le matériel à l'état non monté!



First compare the list of materials with your package contents! Please understand that complaints can be processed in the non-built status only!



Vergelijk eerst de lijst van materialen met de inhoud van uw pakket! Reclamaties kunnen alleen in behandeling worden genomen zolang de onderdelen nog niet zijn gemonteerd!



En primer lugar, compare la lista de material con el contenido del paquete. Rogamos entienda que las reclamaciones sólo pueden ser tramitadas antes de montar el objeto!



Confrontate questa distinta materiali prima con il contenuto del pacchetto! Vi preghiamo di comprendere che eventuali reclami possono essere accolti solo prima del montaggio!



60787

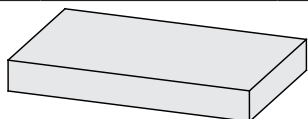

7 x	<b>1A</b>	210 x 115 x 27,5mm	ID 63047
5 x	<b>1</b>	300 x 115 x 27,5mm	ID 38801
1 x	<b>1B</b>	300 x 115 x 82mm	ID 63048



60 x	4 x 50mm	ID 3688
------	----------	---------

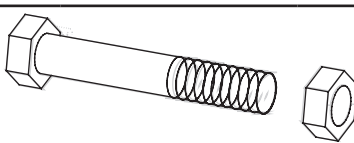

3 x	170 x 12mm	ID 63049
-----	------------	----------

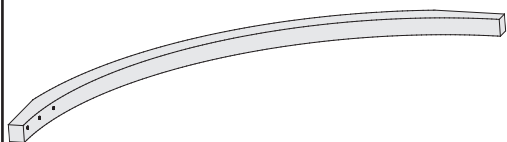

1 x	<b>10</b>	2660 x 90 x 90mm	ID 55478
-----	-----------	------------------	----------

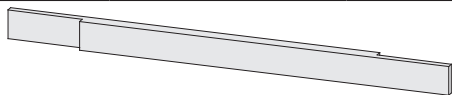

1 x	<b>2</b>	2190 x 115 x 55mm	ID 38797
2 x	<b>3</b>	2400 x 115 x 55mm	ID 38796

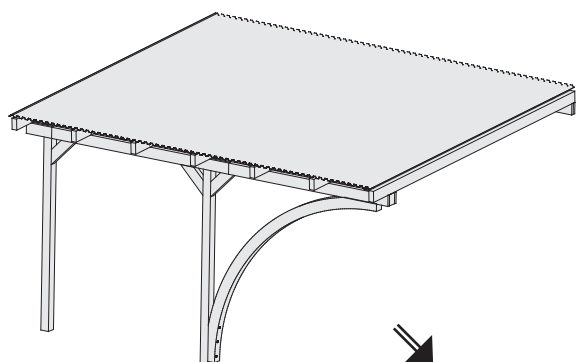

01 → 14

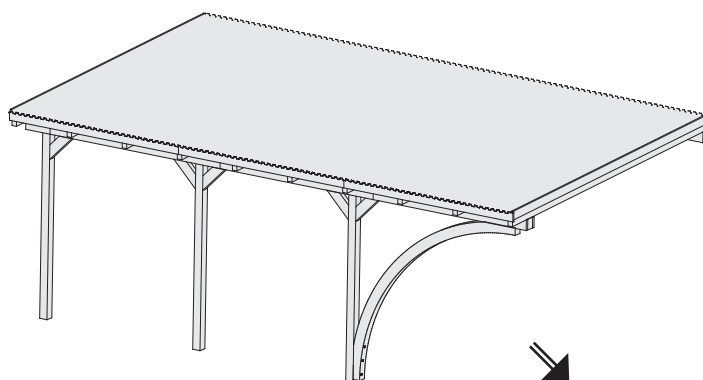

15 → 29

### **Lagerung**

*Prüfen Sie genau Ihre gelieferte Ware, spätere Reklamationen können nicht anerkannt werden.*

*Bitte beachten Sie diese Lagerungs- und Verarbeitungshinweise. Bei Nichteinhalten keine Reklamationsansprüche!*

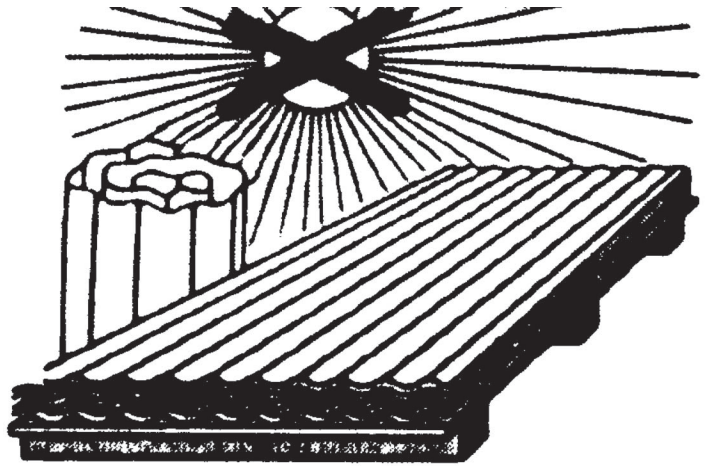

- Hitzestau und Nässe vermeiden.
- PVC-Tafeln dürfen im Stapel nicht dem Sonnenlicht und der Feuchtigkeit ausgesetzt werden. Es besteht Gefahr der Überhitzung (Brennglaswirkung!).
- Die maximale Lagerungstemperatur im Stapel darf 60°C nicht überschreiten. Für Brennglasschäden übernehmen wir keine Haftung.
- Auf ebener, nicht aufgeheizter Unterlage lagern und mit licht- und wasserundurchlässigen hellen Planen abdecken.
- Stapelhöhe max 50 cm
- Max Raumtemperatur: 40°C
- Während der Lagerung müssen PVC-Tafeln von Witterungseinflüssen, Verschmutzung und mechanischen Belastungen geschützt werden.

### **Montage**

- Nicht bei Temperaturen unter 5°C durchführen.
  - Montagebedingte manuelle Transporte einzelner Platten nicht bei Wingschwindigkeit über 3m/s durchführen.
  - Bei der Montage von Doppelstegplatten ist die Wandanschlussseite mit einer Dichtung abzuschließen, sodass das Eindringen von Staub und Regenwasser verhindert wird.
- Aufgrund von verschiedenen Anbauoptionen ist das Dichtband nicht im Lieferumfang enthalten.

### **Reinigung**

- Der Reinigungszyklus ist abhängig vom Verschmutzungsgrad, sollte jedoch von außen mindestens einmal jährlich erfolgen.
- Verschmutzungen mit Wasser oder Haushaltsreinigungsmitteln beseitigen.
- Keine scheuernden, ätzenden oder lösungsmittelhaltigen Zusätze verwenden.

### *Storage*

*Check your delivered goods with extreme care, as later complaints cannot be entertained.*

*Please observe these storage and processing instructions. In the event of a failure to observe these instructions, claims relating to complaints will not be entertained!*

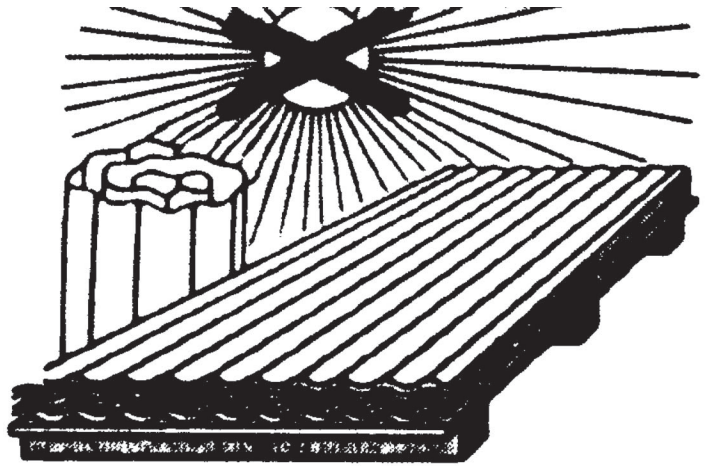

- Avoid heat accumulation and damp.
- Stacked PVC sheets should not be exposed to sunlight and moisture. A risk of overheating exists (risk of fire through focusing of solar radiation!).
- The maximum storage temperature when stacked should not exceed 60°C. We assume no liability for damage caused by the focusing of solar radiation in this manner.
- Store on a level, unheated surface and cover with bright tarpaulin impervious to light and water.
- Max. stack height 50 cm
- Max. room temperature: 40°C
- PVC sheets should be protected during storage against the effects of weather, dirt and mechanical loads or stress.

### *Installation*

- Do not install at temperatures under 5°C.
  - Manual transportation of individual sheets necessary for installation should not be realised at wind speeds exceeding 3m/s.
  - When installing double-web sheets, the wall connection side should be fitted with a seal to prevent the penetration of dust and rainwater.
- Sealing tape is not included in the scope of delivery, due to the different attachment options involved.

### *Cleaning*

- The cleaning cycle depends on the level of dirt, but exterior cleaning should be realised at least once a year.
- Remove dirt with water or a household cleaning agent.
- Do not use any scouring or caustic additives or additives containing solvents.

### *Stockage*

*Contrôlez la marchandise reçue avec précision, une réclamation ultérieure ne pourra être prise en compte.*

*Veuillez observer ces remarques sur le stockage et l'utilisation des plaques. Aucune réclamation ne pourra être acceptée en cas de non-respect !*

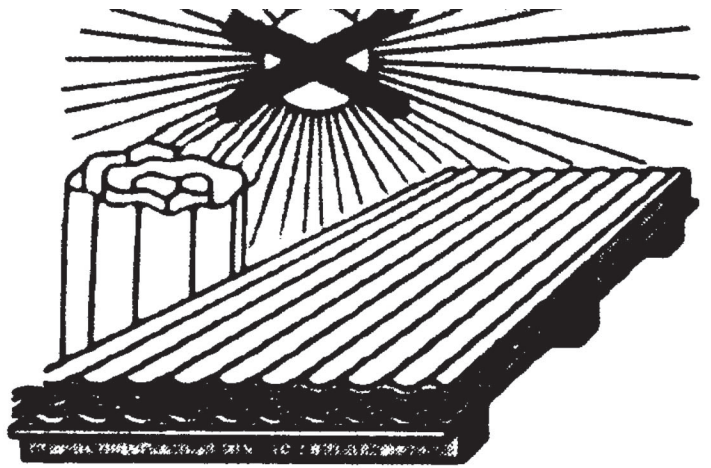

- Éviter l'accumulation de chaleur et l'humidité.
- S'ils sont empilés, les panneaux PVC ne doivent pas être exposés à la lumière du soleil ni à l'humidité. Risque de surchauffe (effet de loupe) !
- La température de stockage max. à l'intérieur de la pile ne doit pas dépasser 60 °C. Nous déclinons toute responsabilité en cas de dommages causés par un effet de loupe.
- Stocker sur une surface plane non chauffée et recouvrir de bâches claires opaques et imperméables à l'eau.
- Hauteur max. d'une pile : 50 cm
- Température ambiante max. : 40 °C
- Pendant le stockage, les panneaux PVC doivent être protégés des intempéries, de la saleté et des contraintes mécaniques.

### *Montage*

- Ne pas réaliser le montage si la température est inférieure à 5 °C.
  - Ne pas effectuer le transport manuel de plaques individuelles nécessaire lors du montage si la vitesse du vent est supérieure à 3m/s.
  - Lors du montage de plaques alvéolaires, obturer le côté de raccordement au mur avec un joint pour empêcher la poussière et l'eau de pluie de pénétrer.
- En raison des différentes options de montage existantes, le ruban d'étanchéité n'est pas inclus dans la livraison.

### *Nettoyage*

- La fréquence de nettoyage est fonction du degré d'encrassement. Au moins un nettoyage extérieur par an est toutefois recommandé.
- Nettoyer les plaques avec de l'eau ou des produits ménagers.
- Ne pas ajouter d'agents abrasifs, corrosifs ou à teneur en solvants.

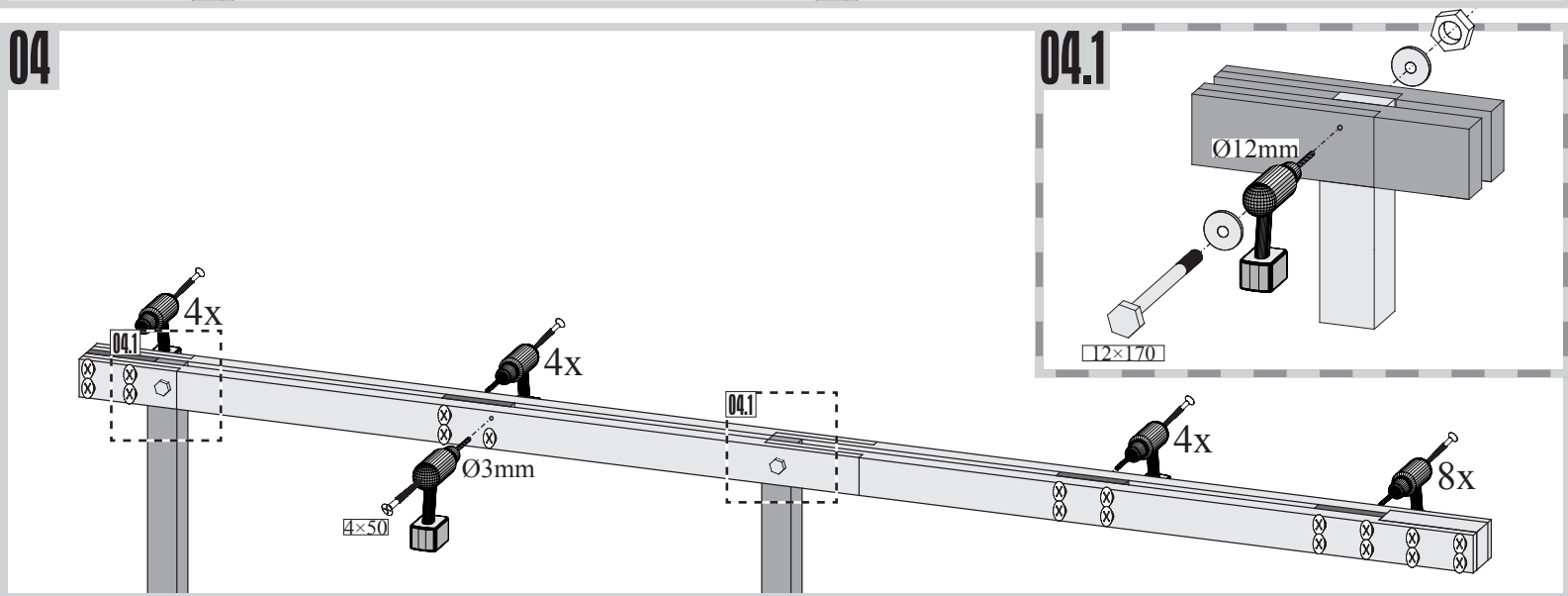
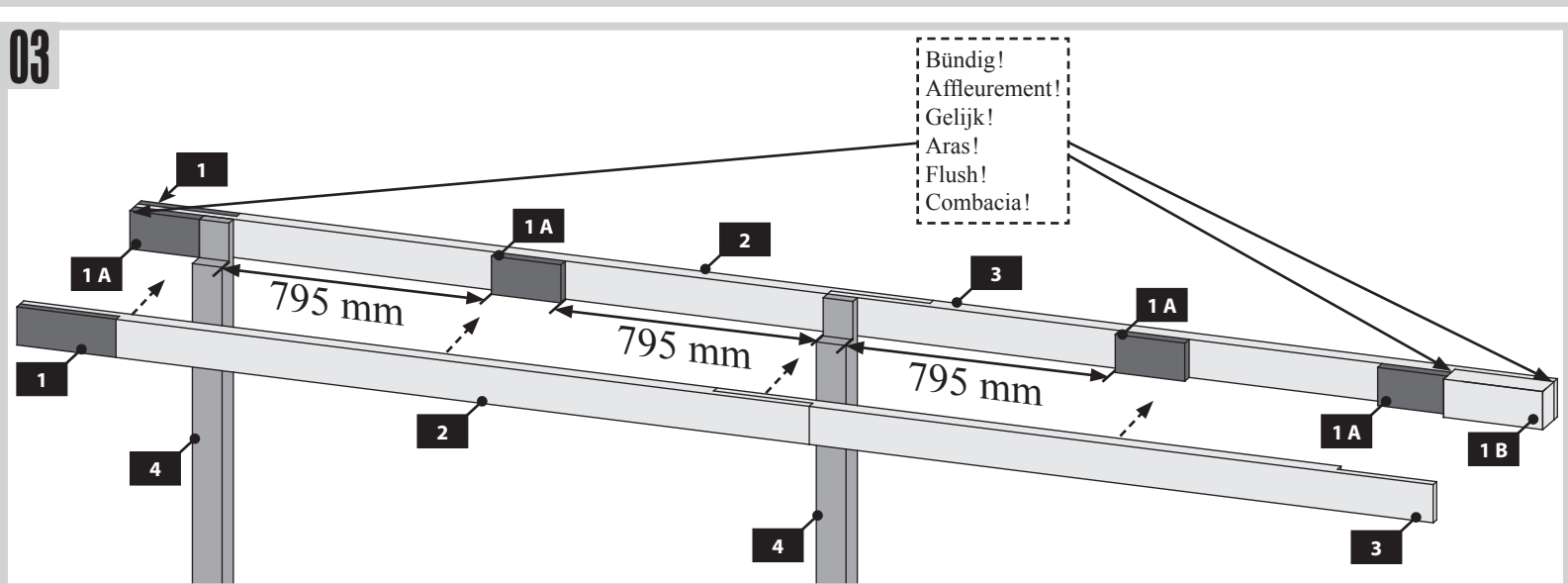
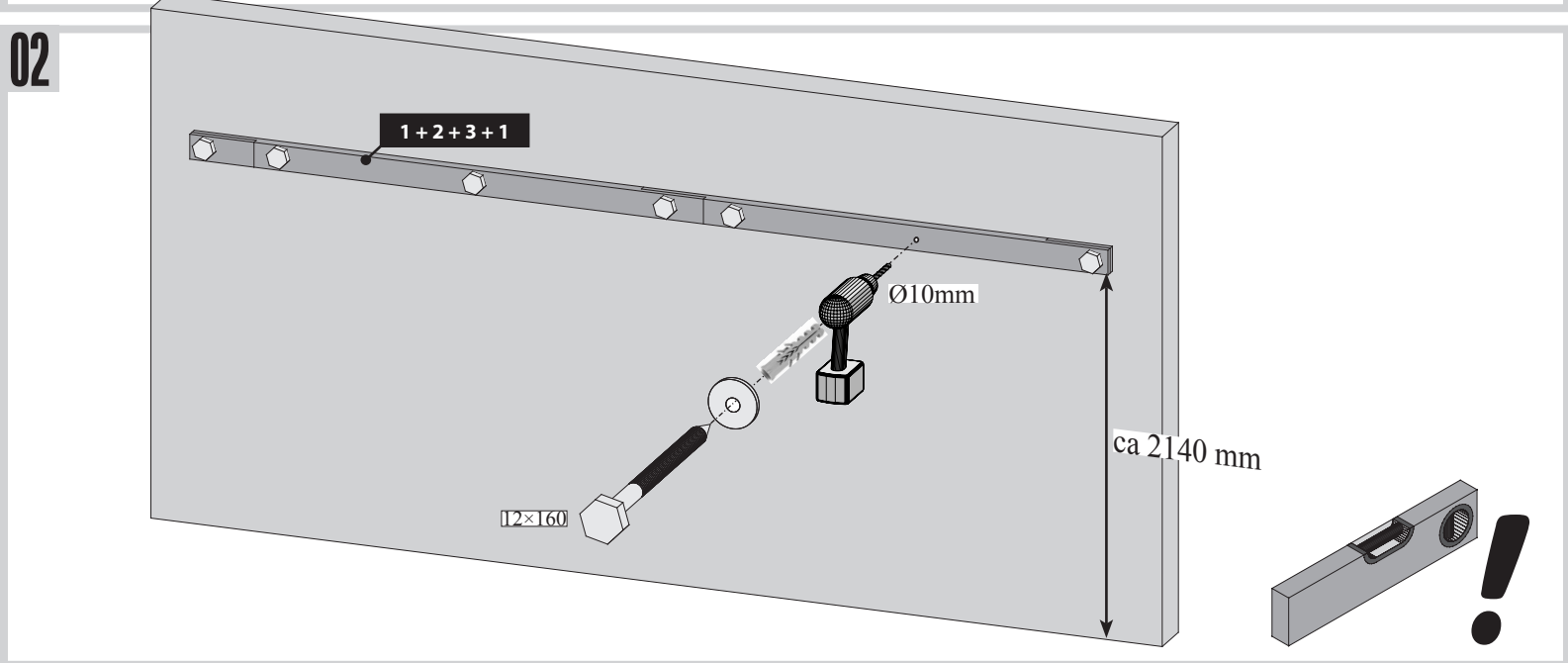
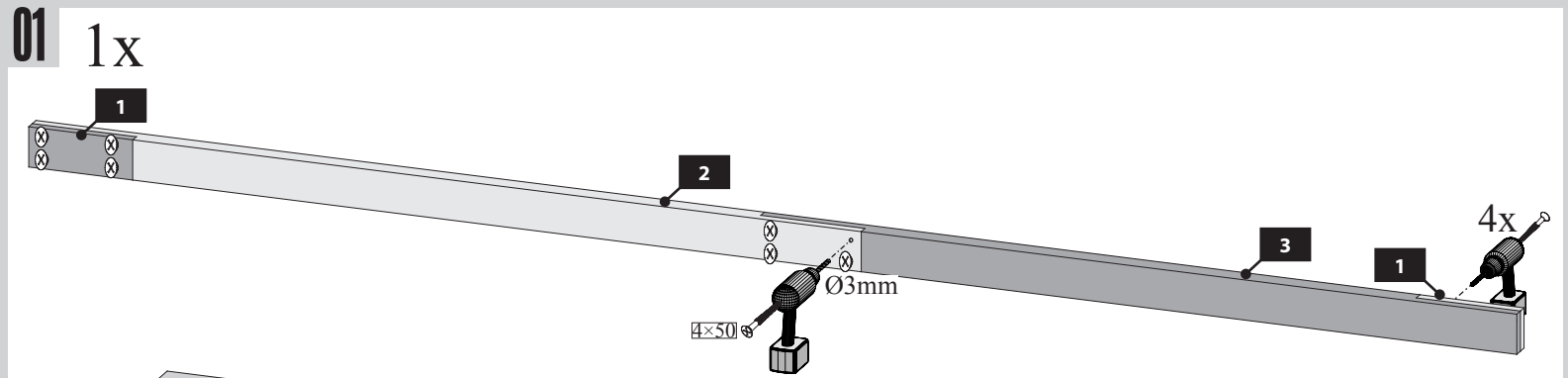

05

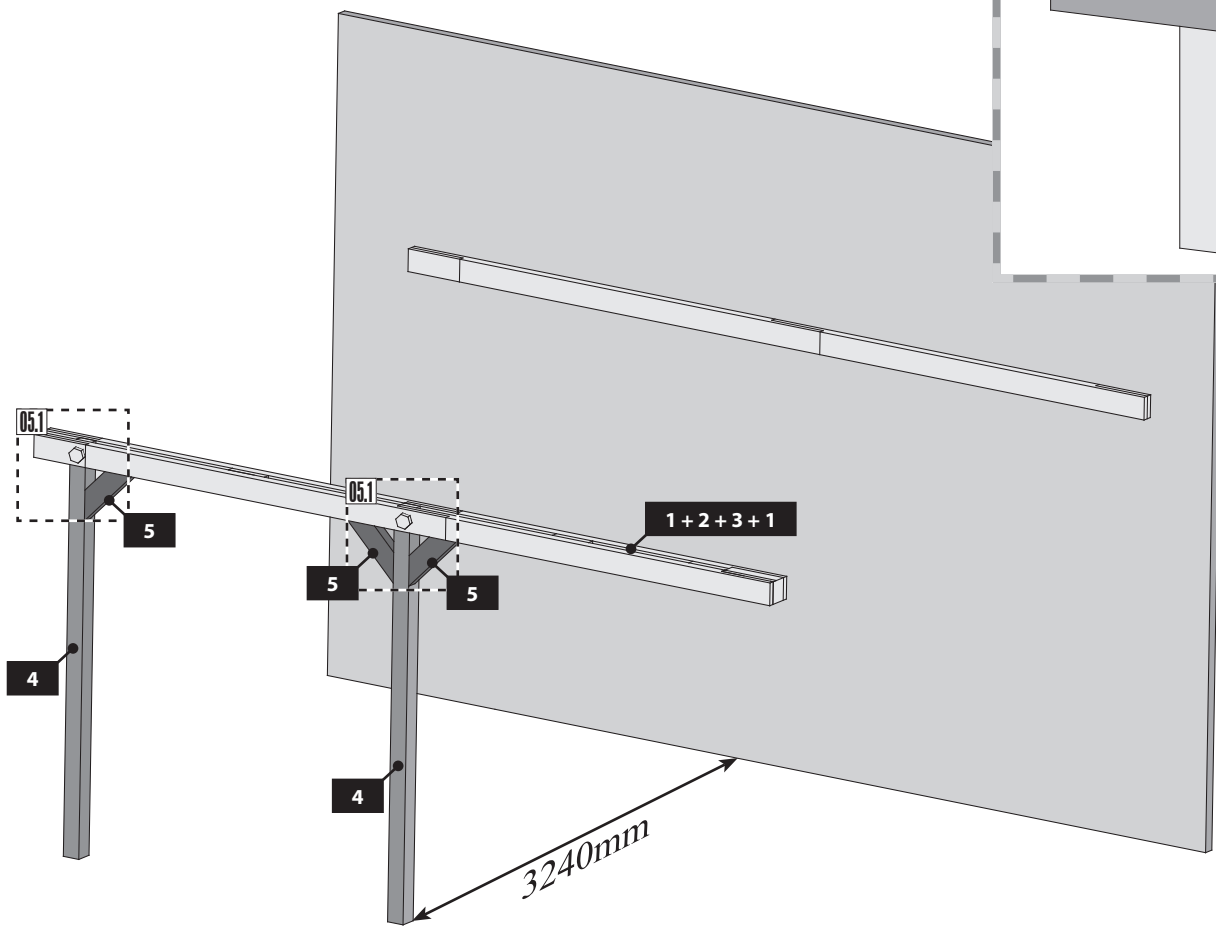

05.1

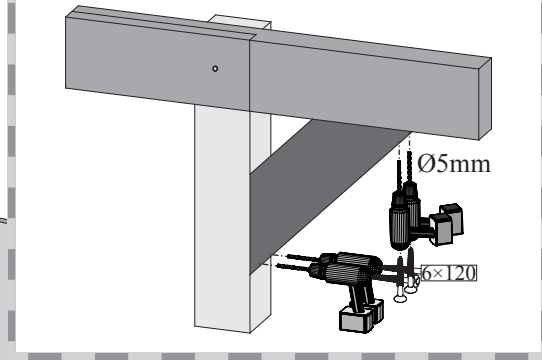

06

**!!! A=B=C=D=E=F!!!**

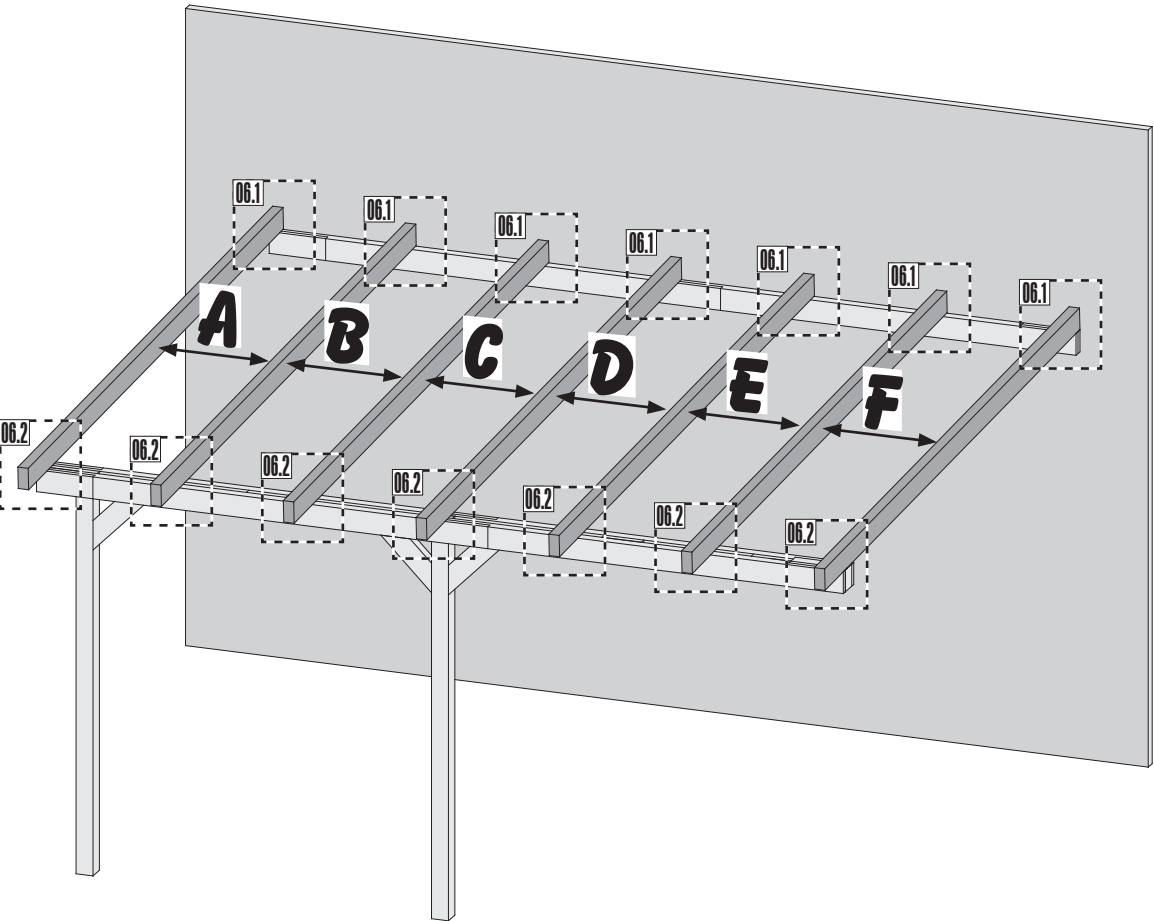

06.1

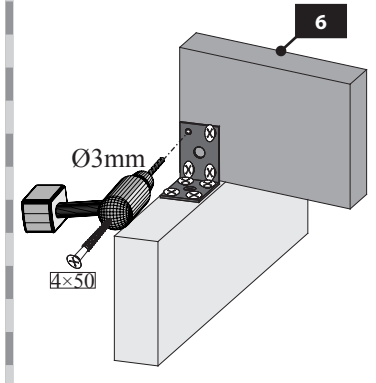

06.2

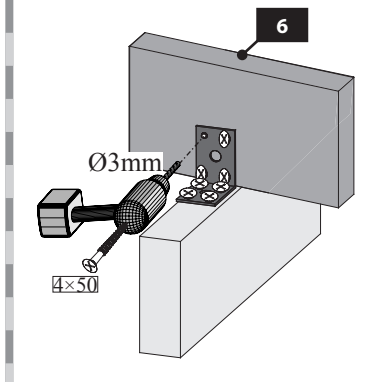

07

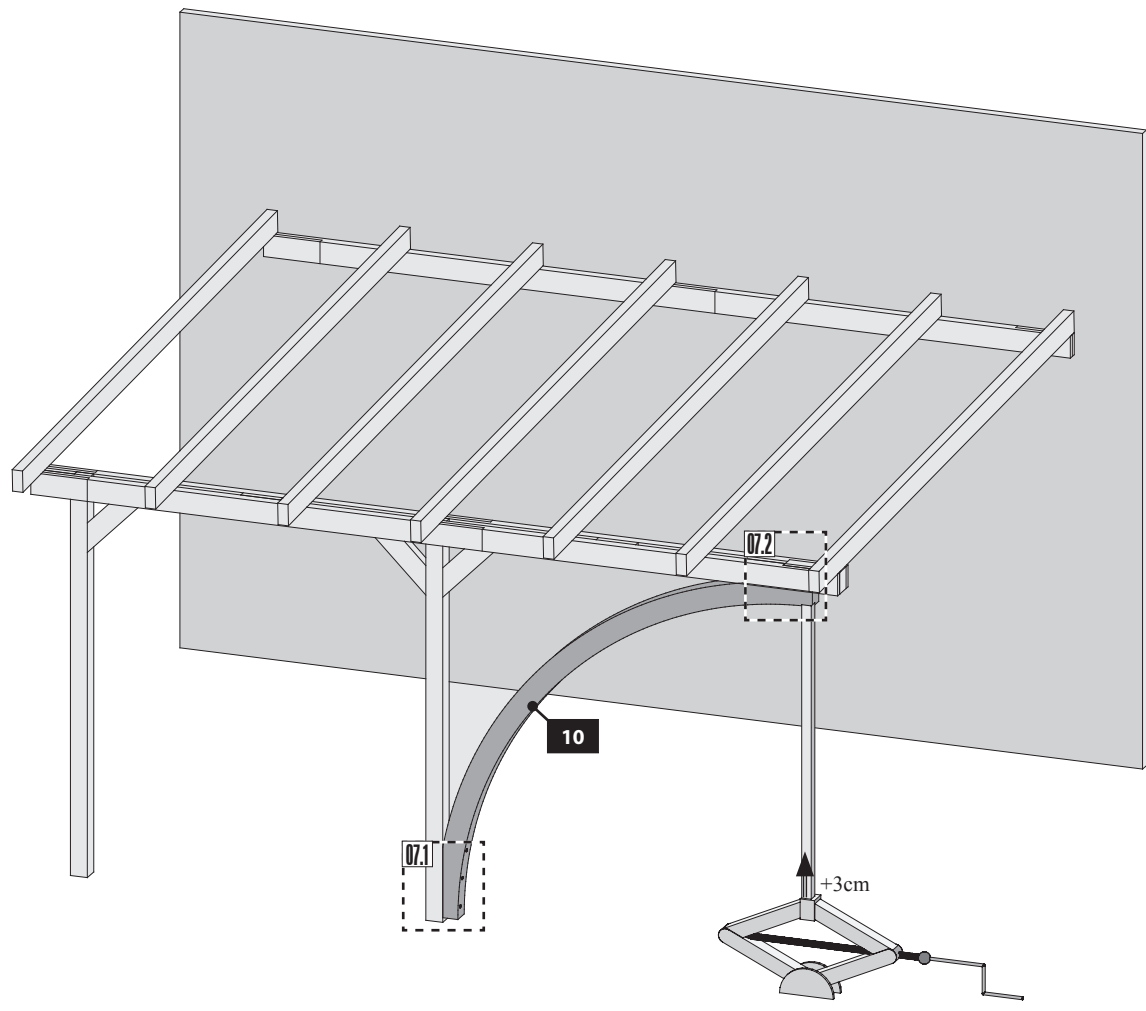

07.1

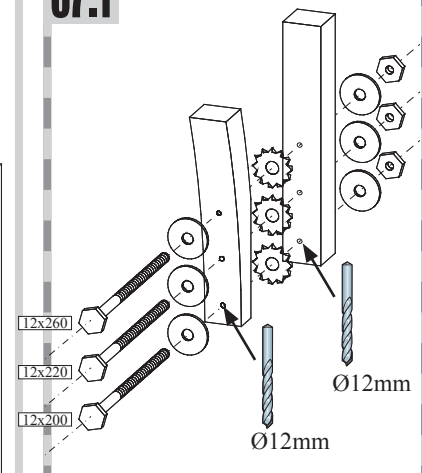

07.2

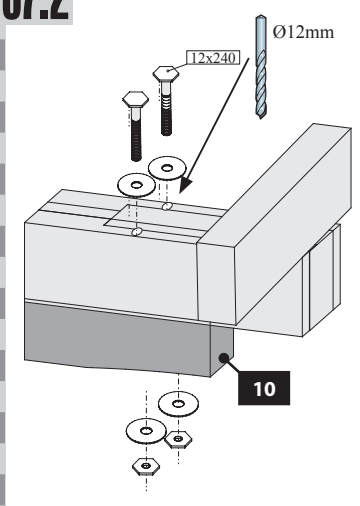

08

**!!! A=B=C=D=E=F=G!!!**

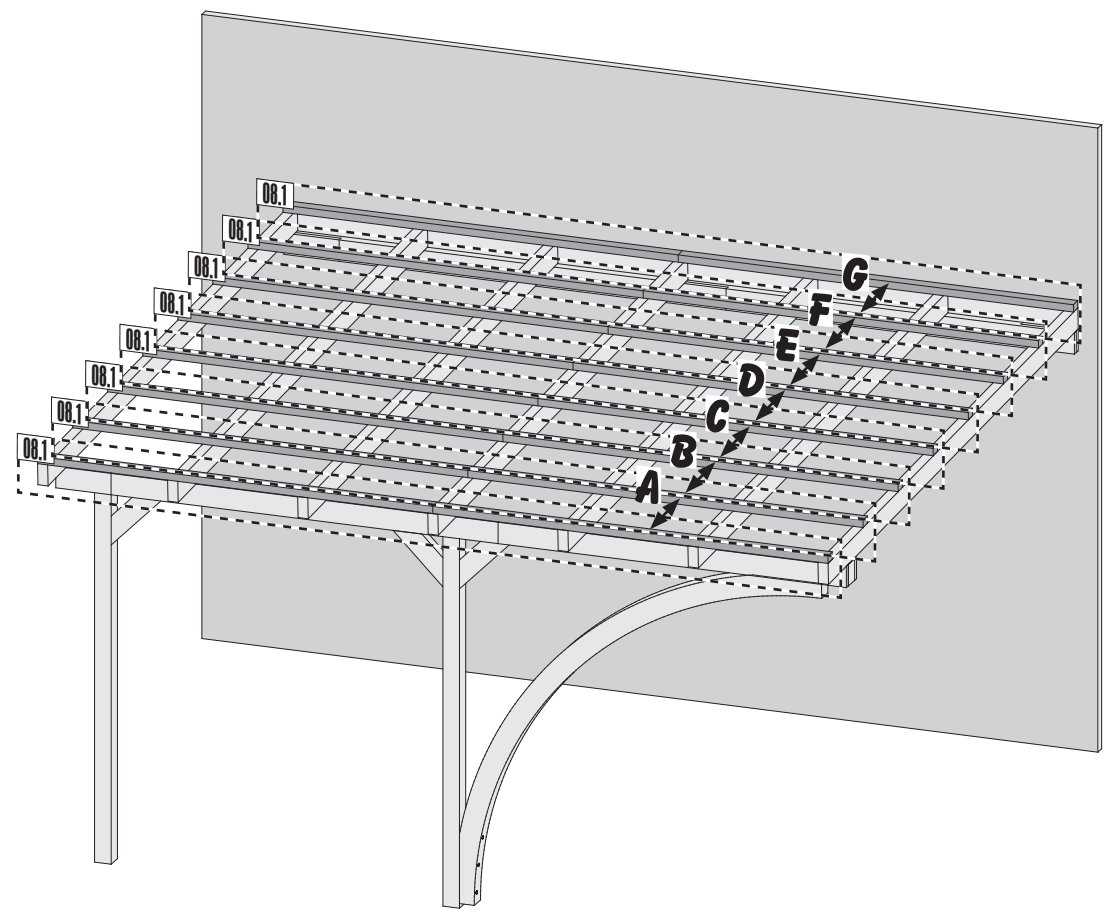

08.1

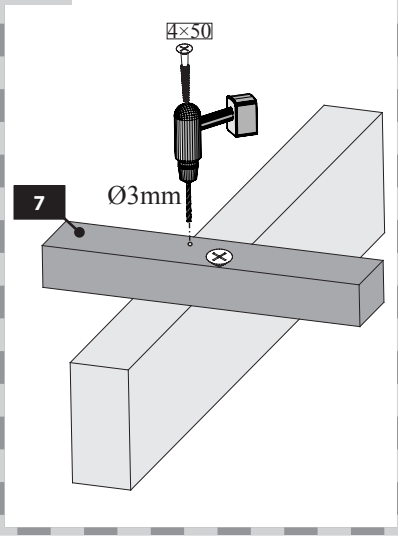



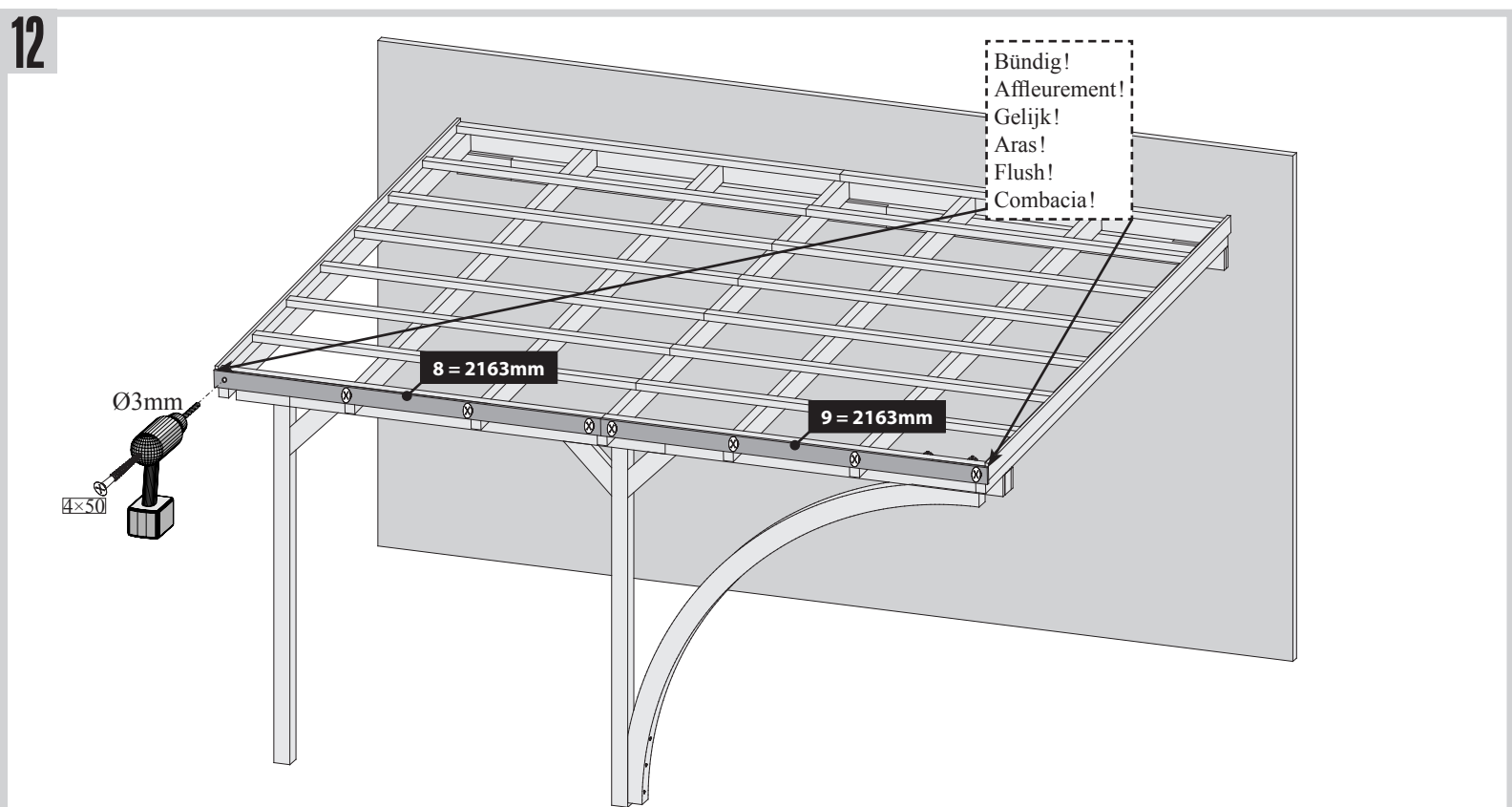
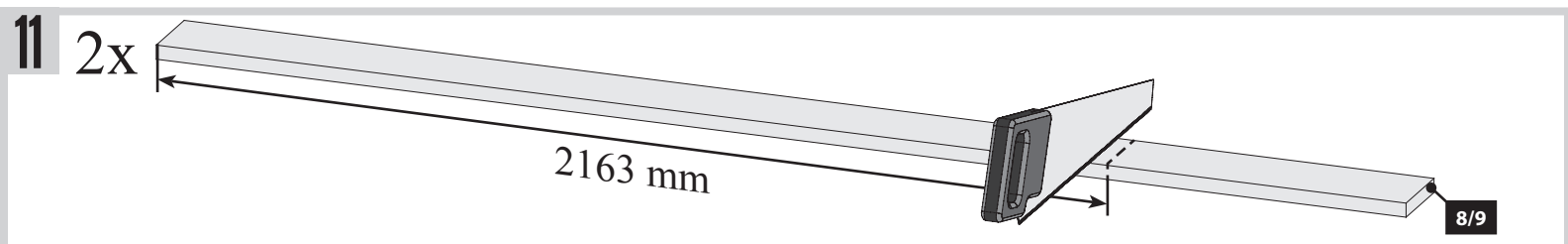
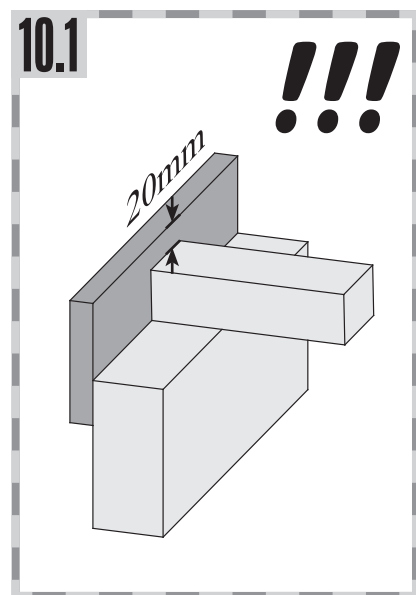
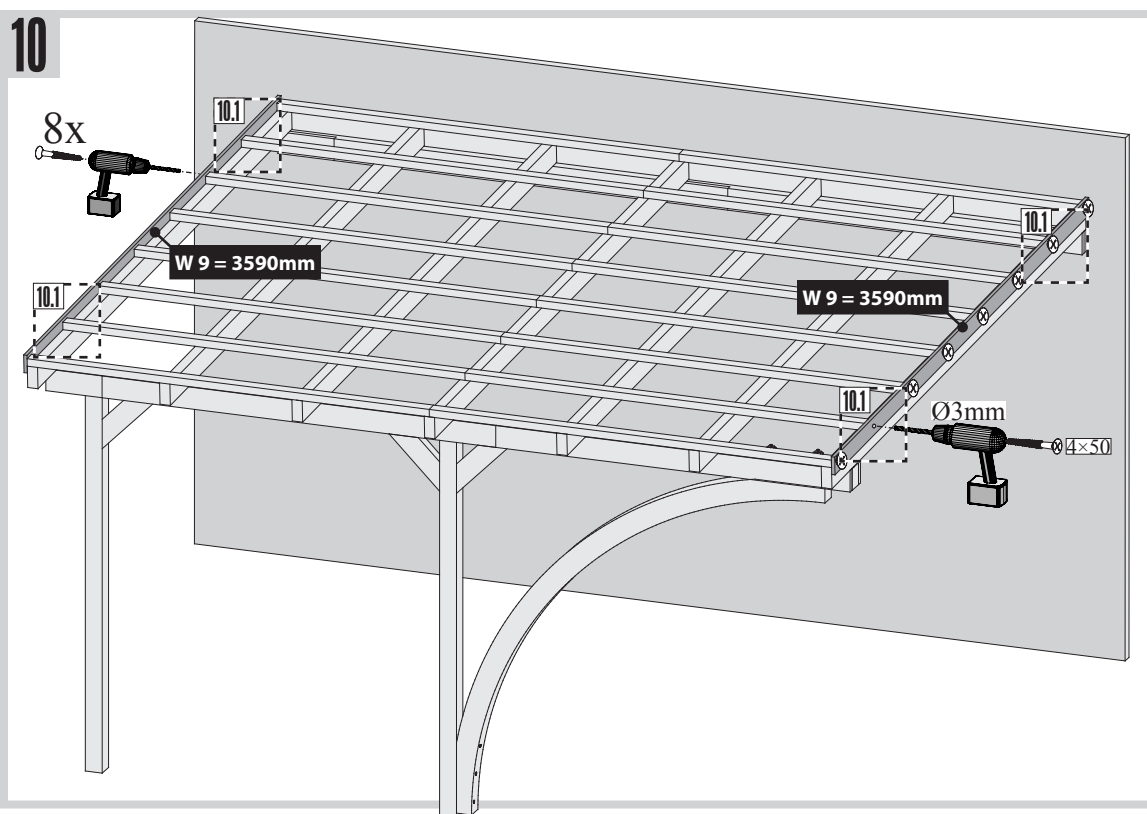
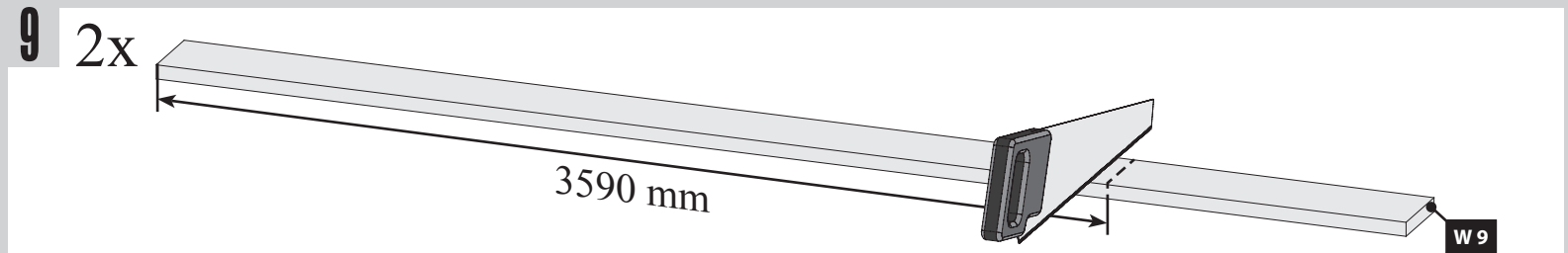

13

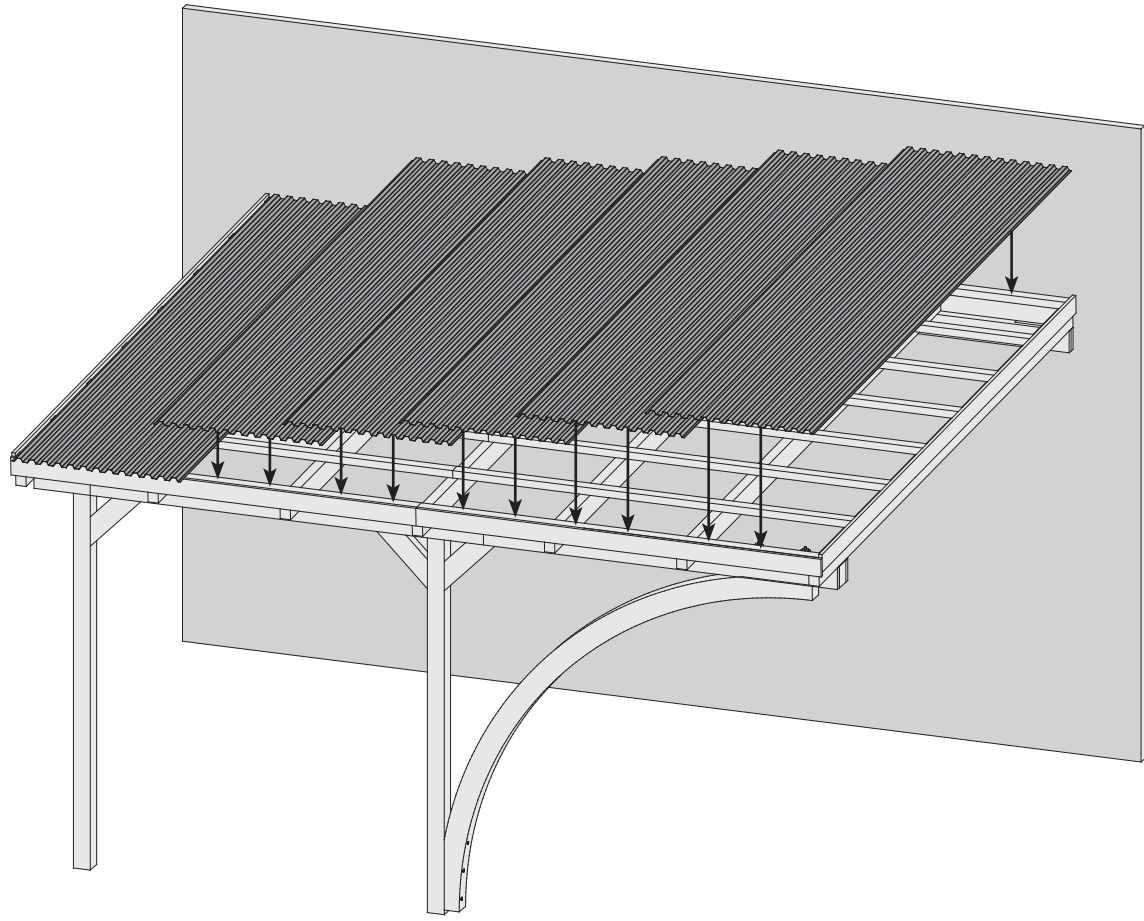

14

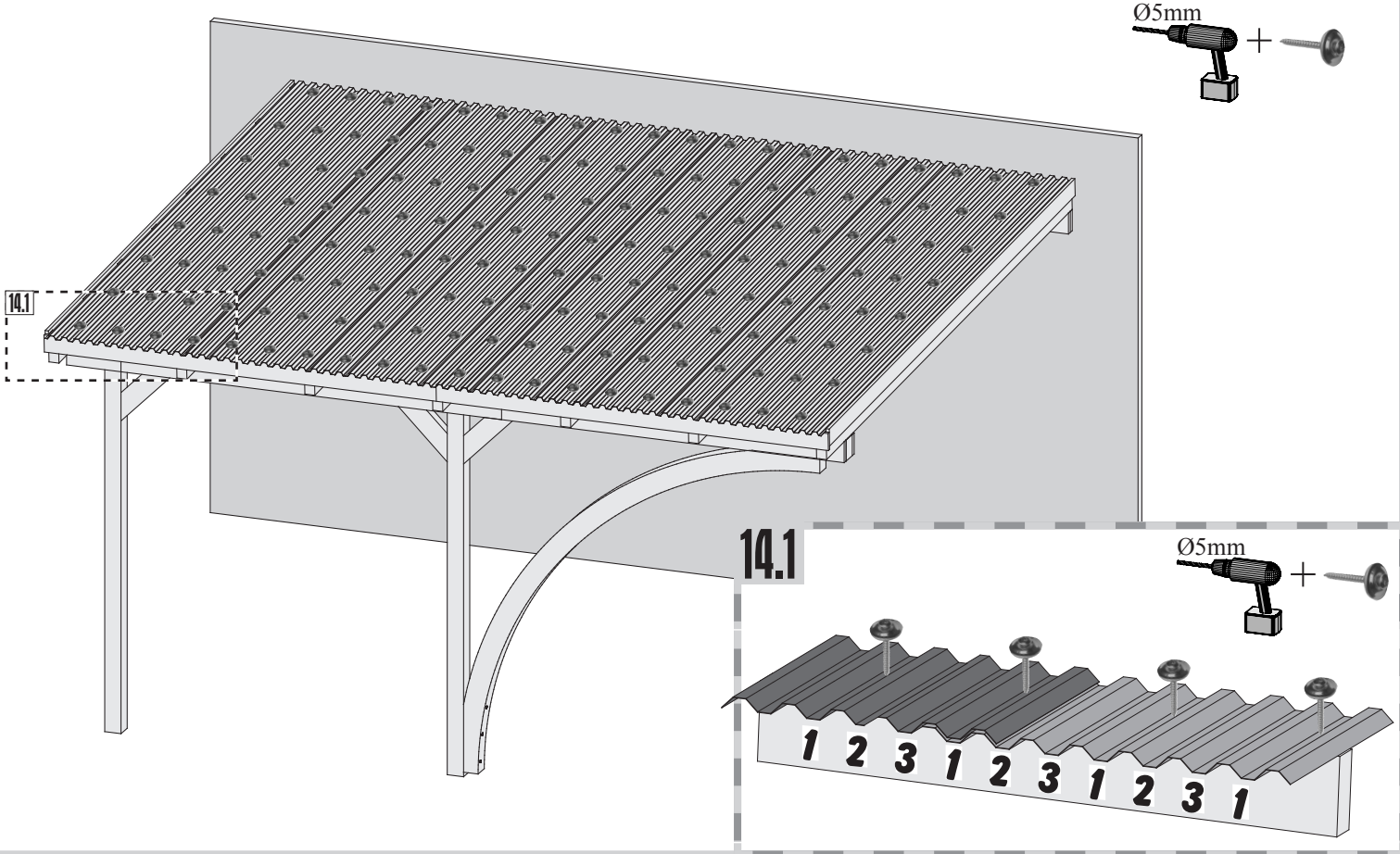

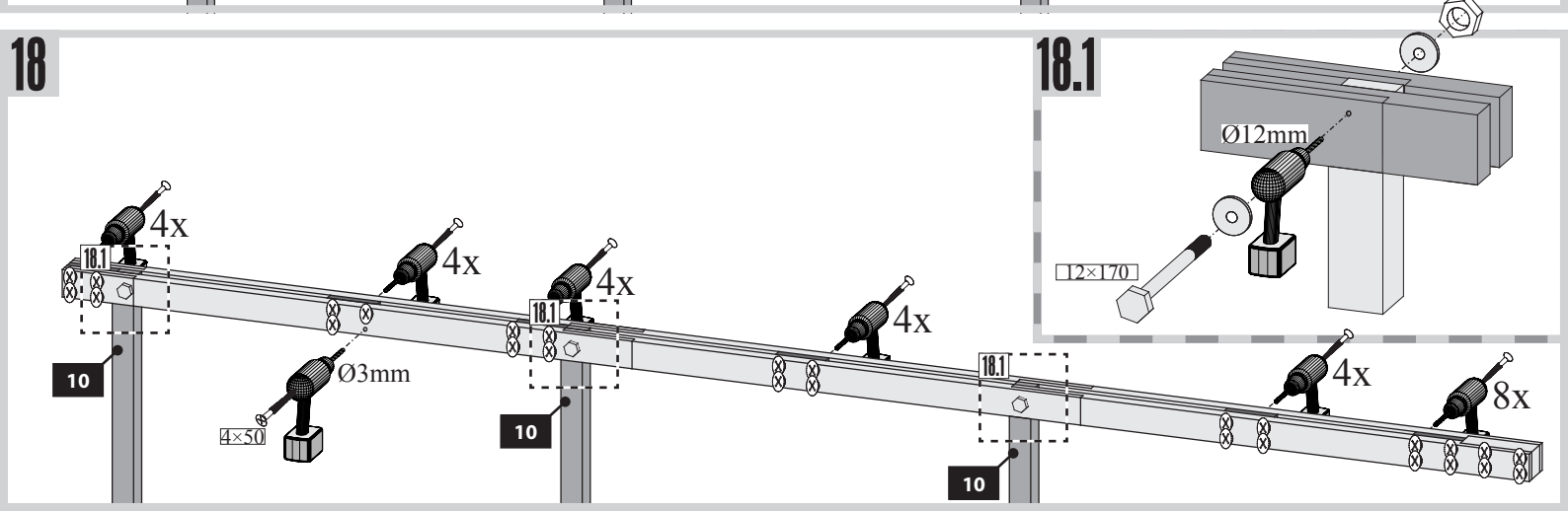
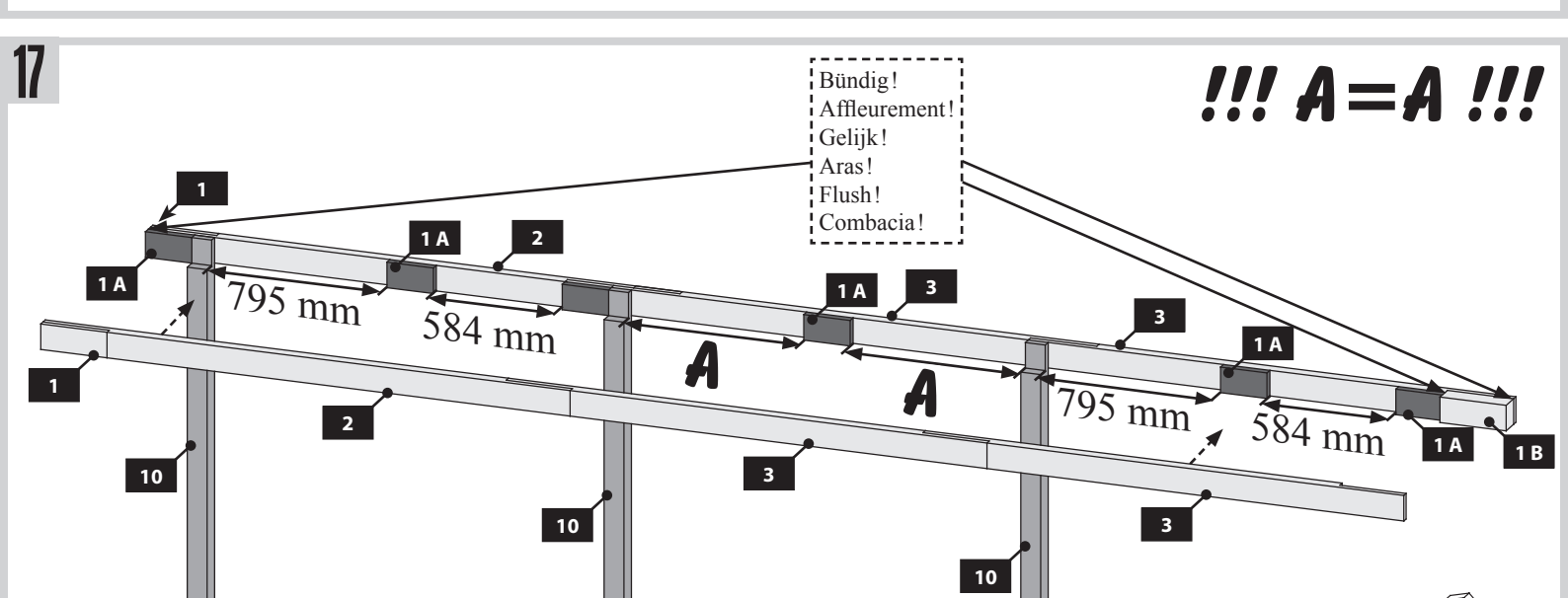
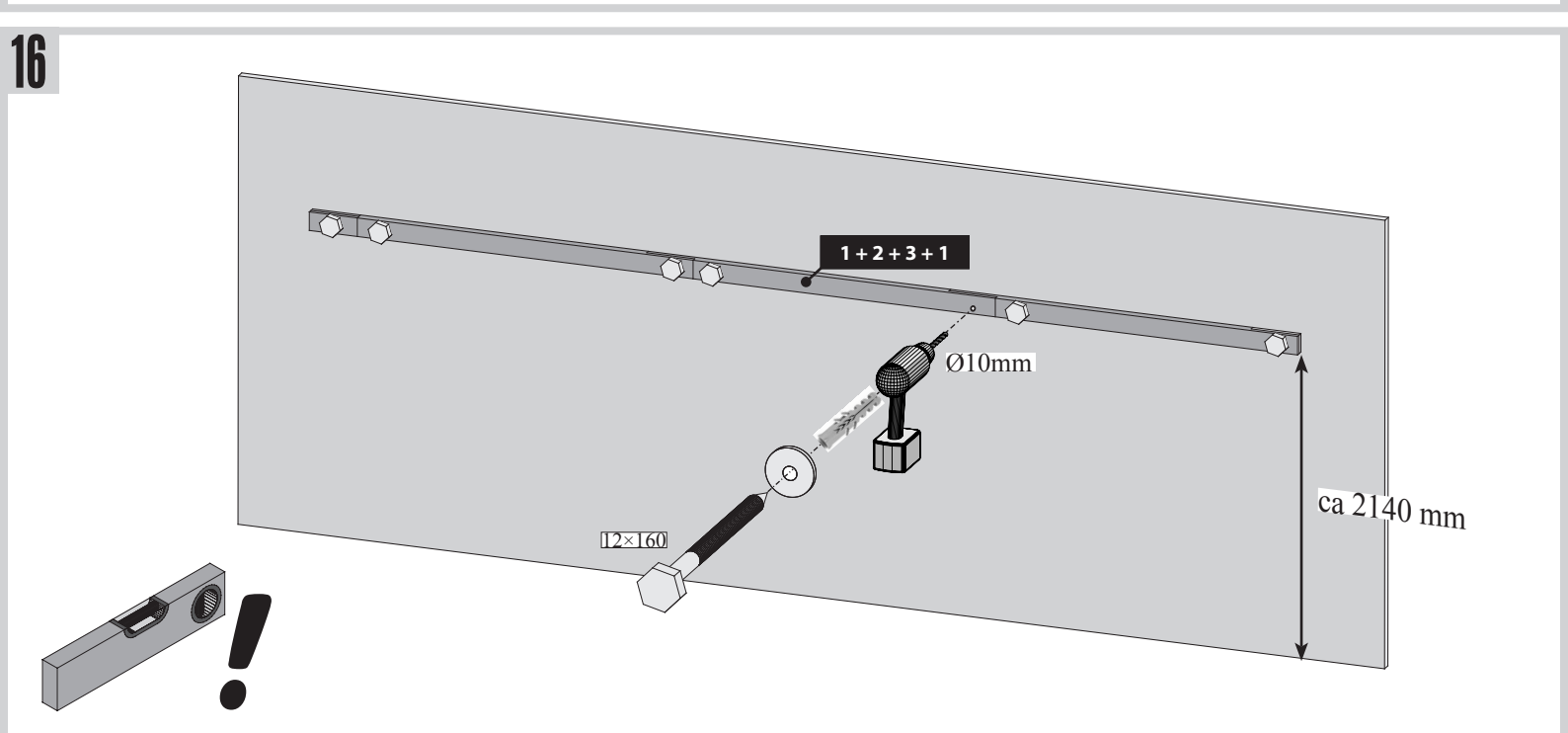
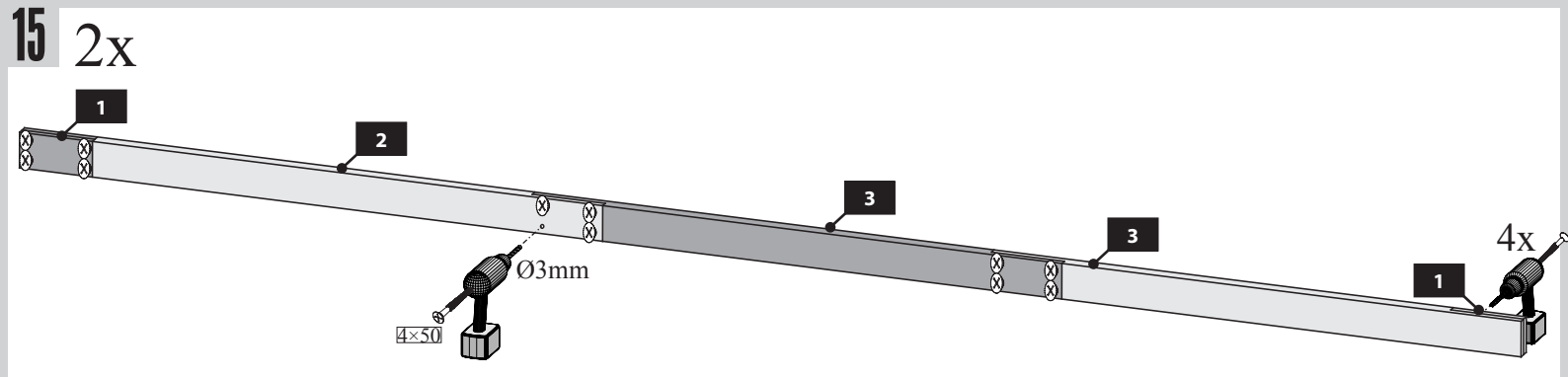

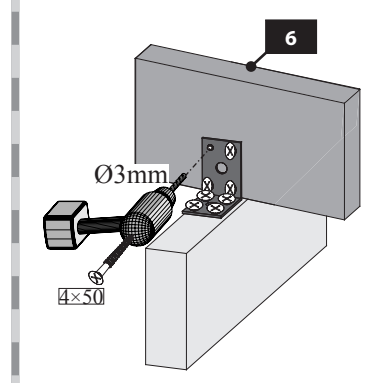
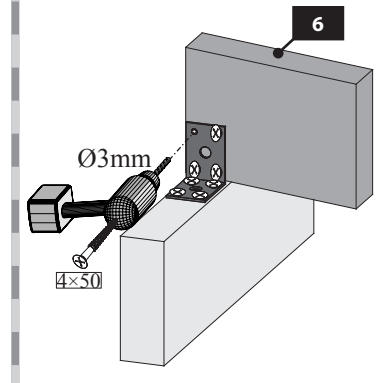
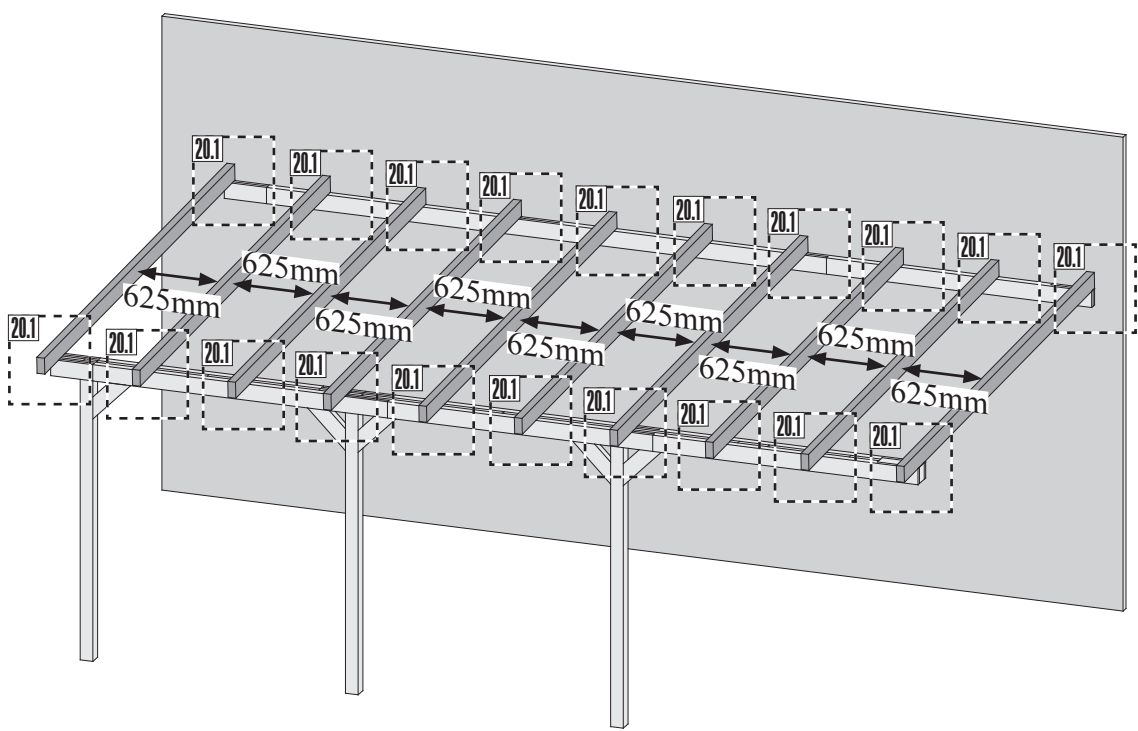
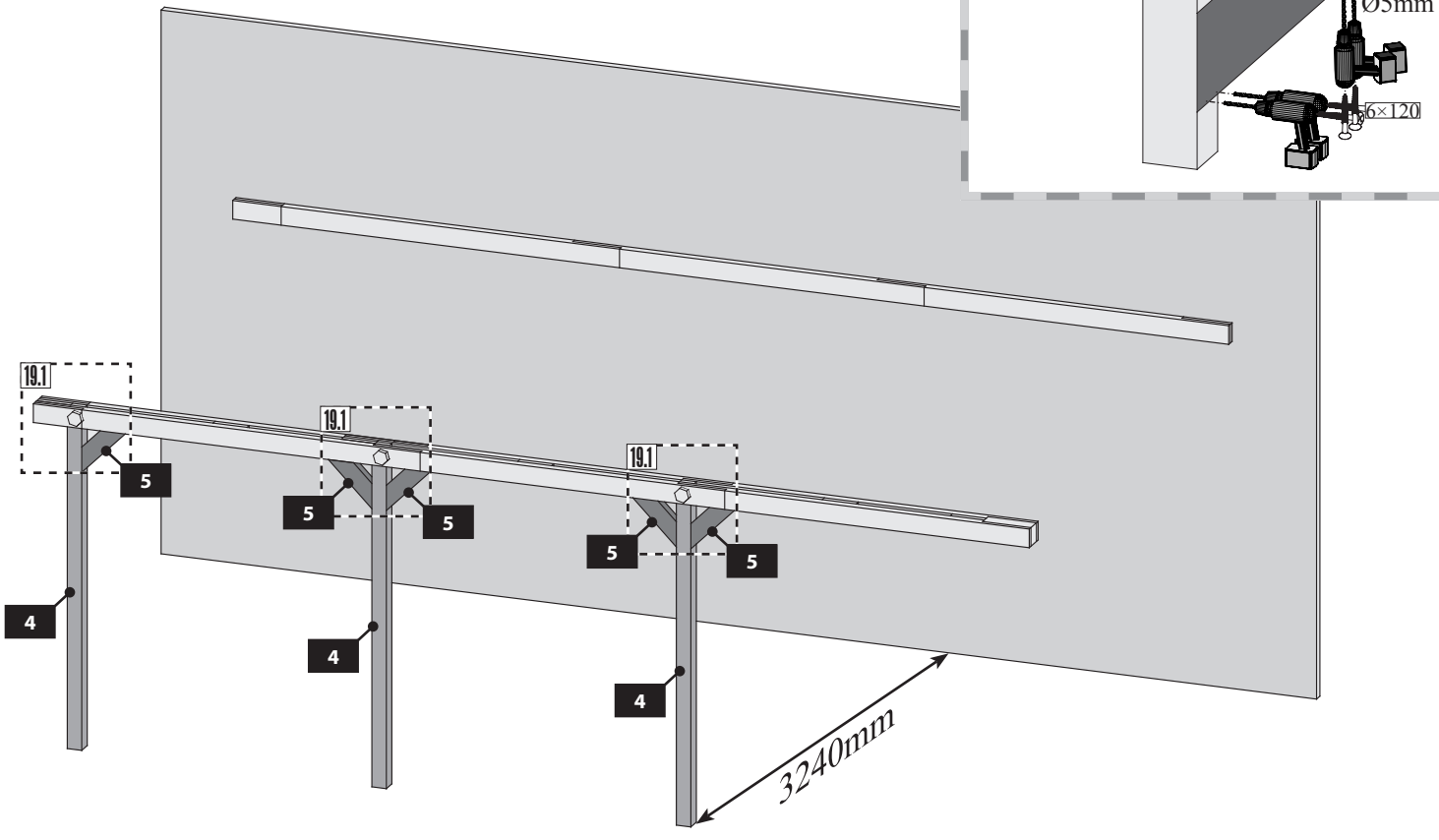

21

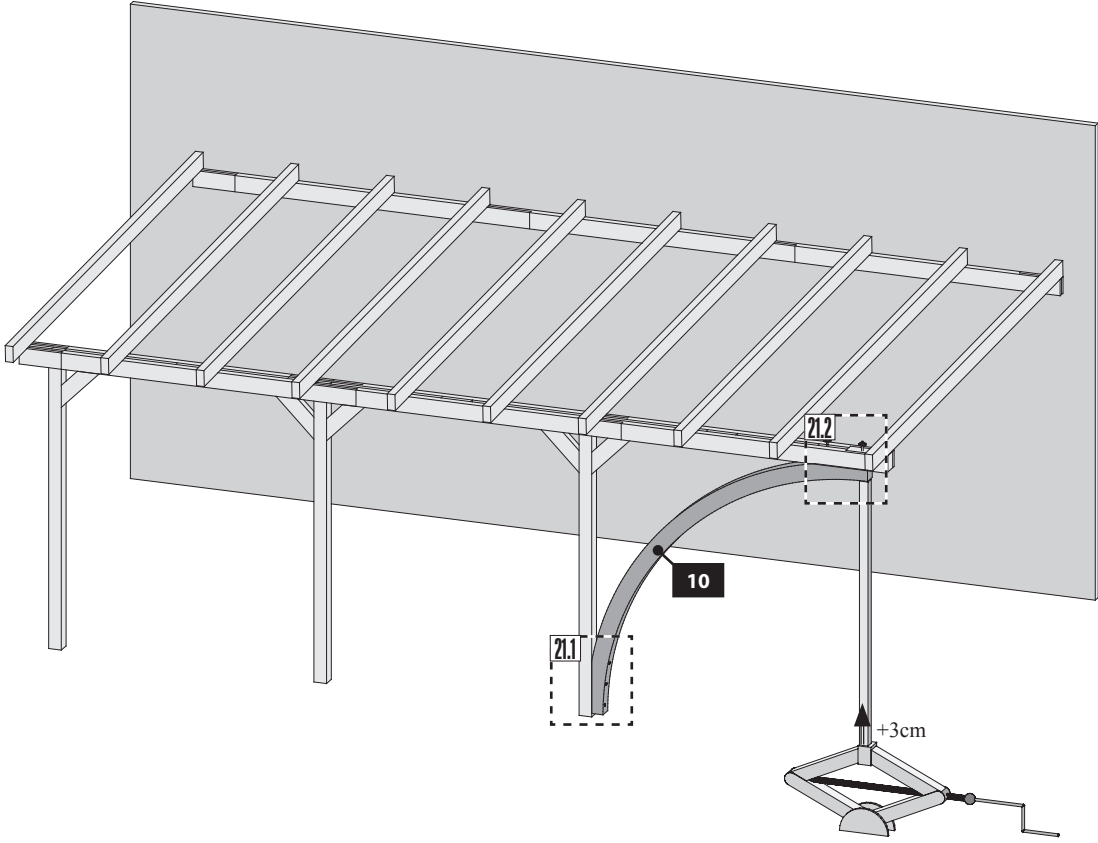

21.1

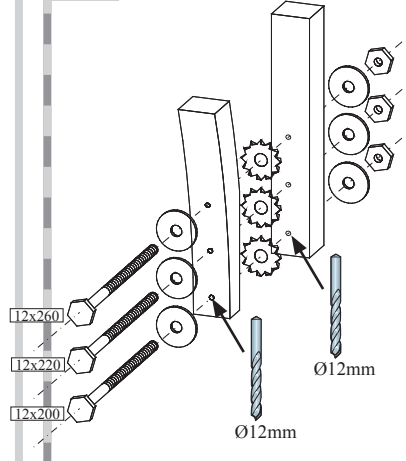

21.2

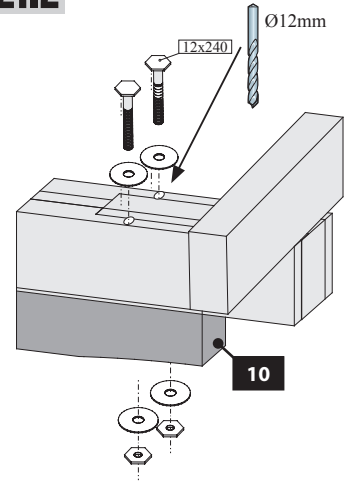

22

**!!! A=B=C=D=E=F=G!!!**

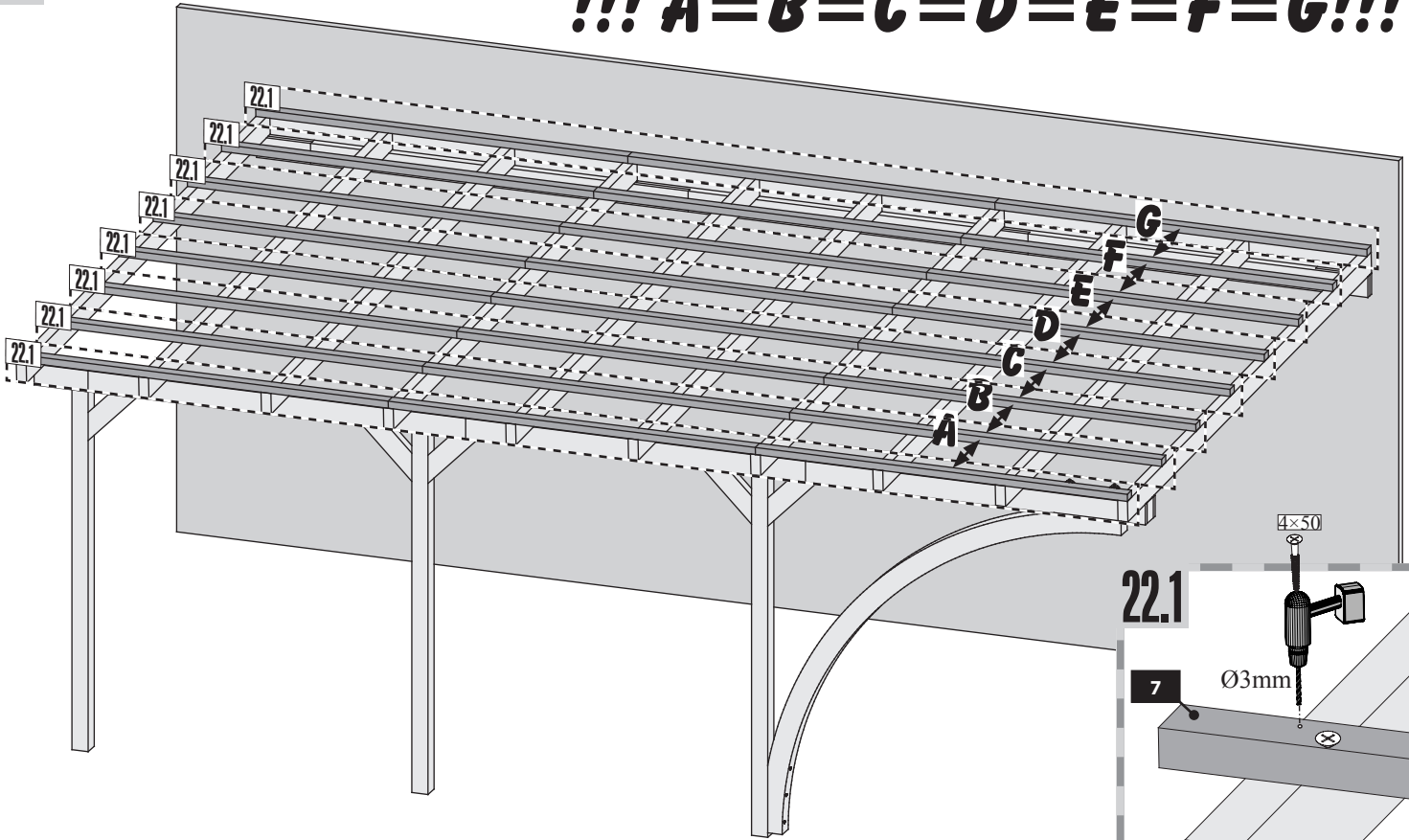

22.1

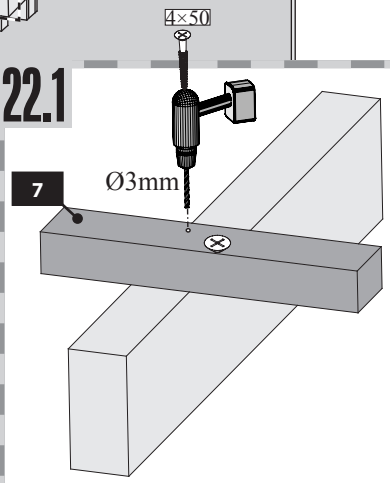

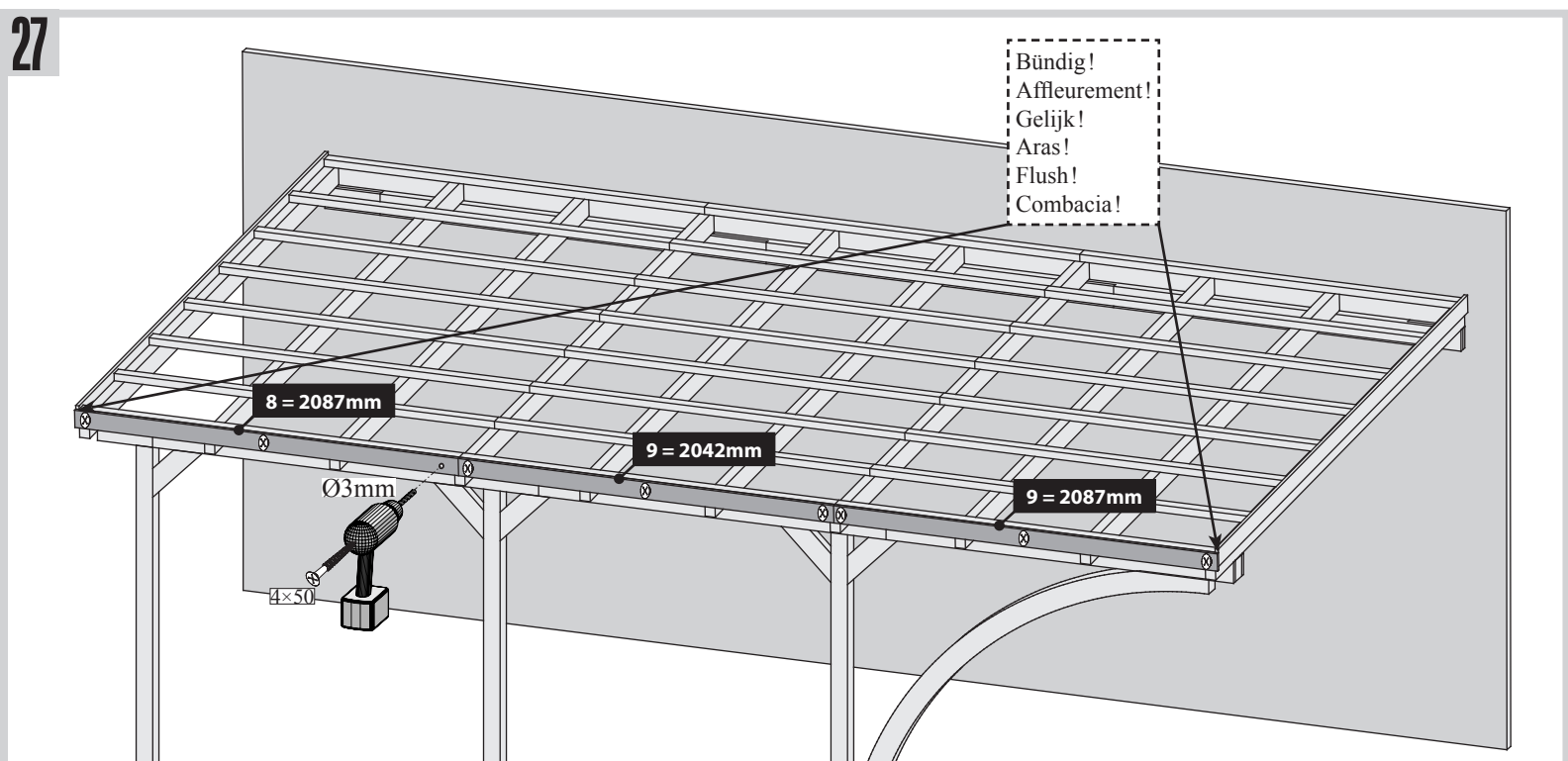
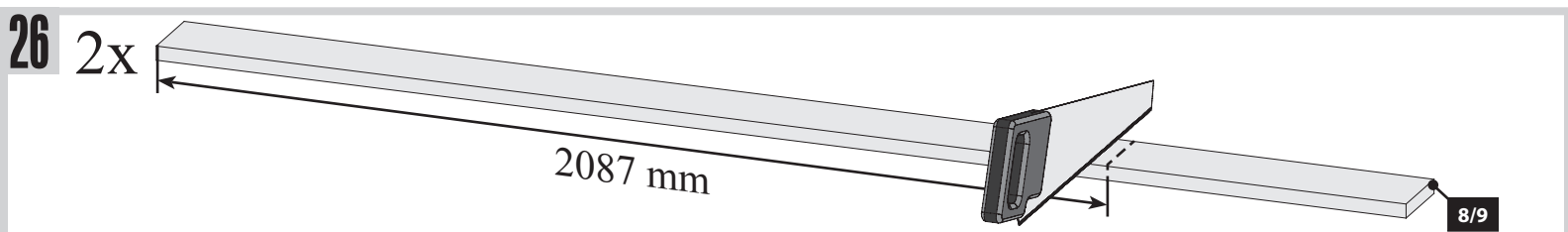
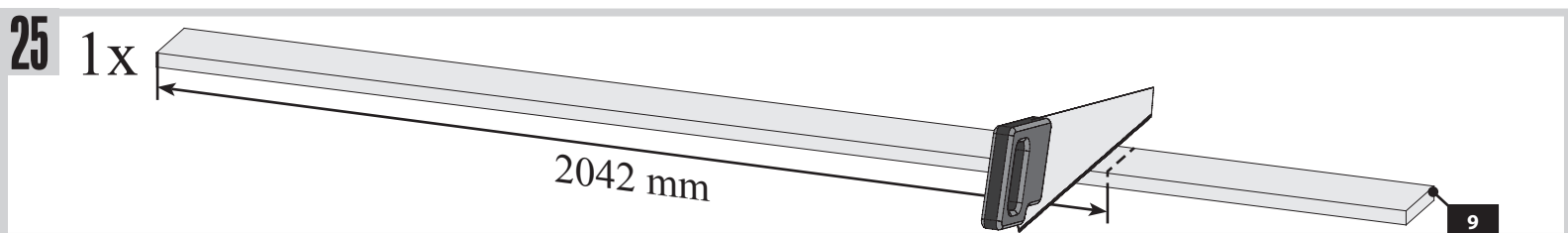
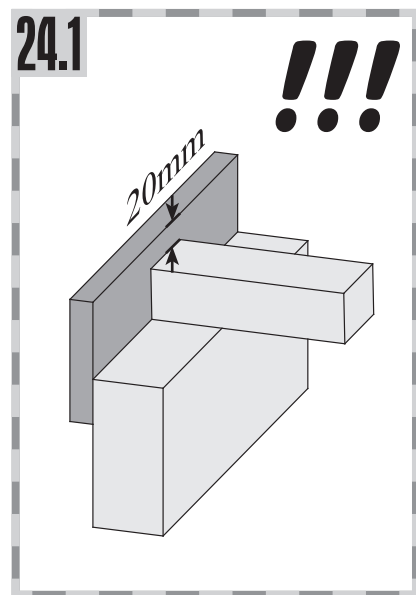
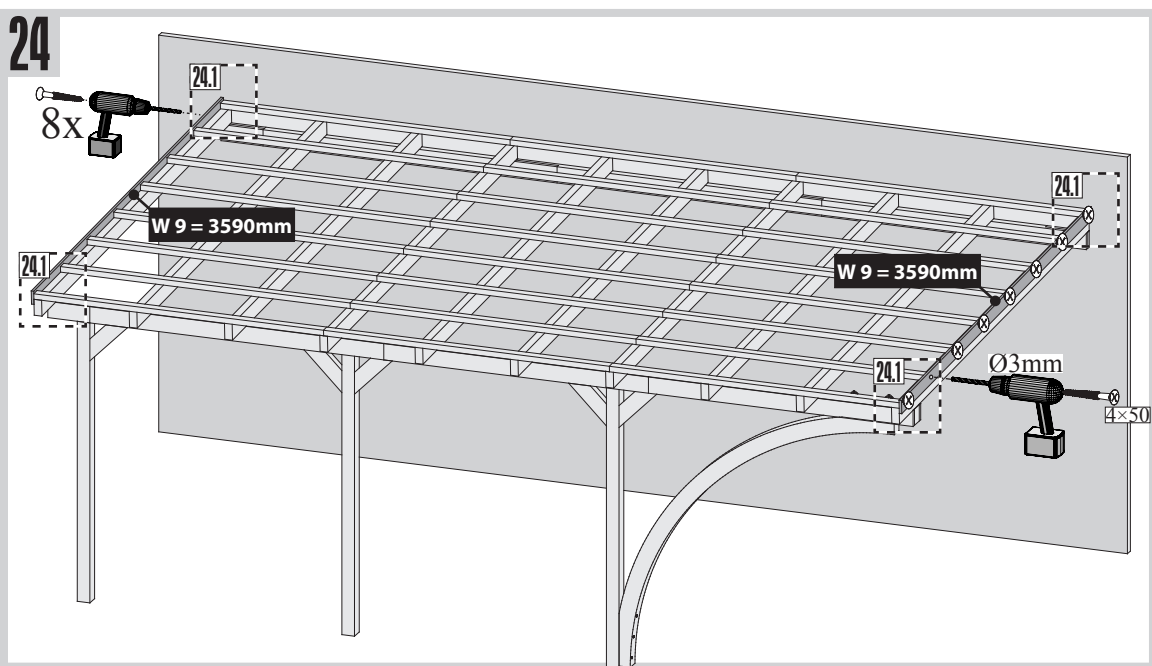
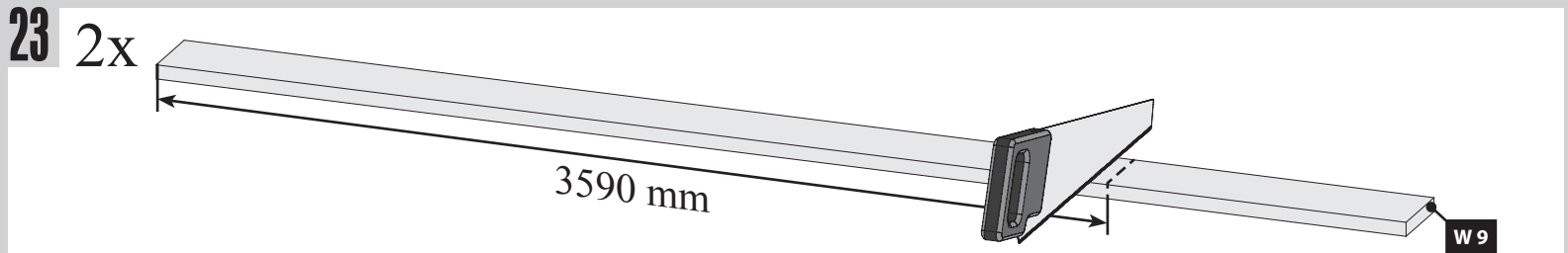

28

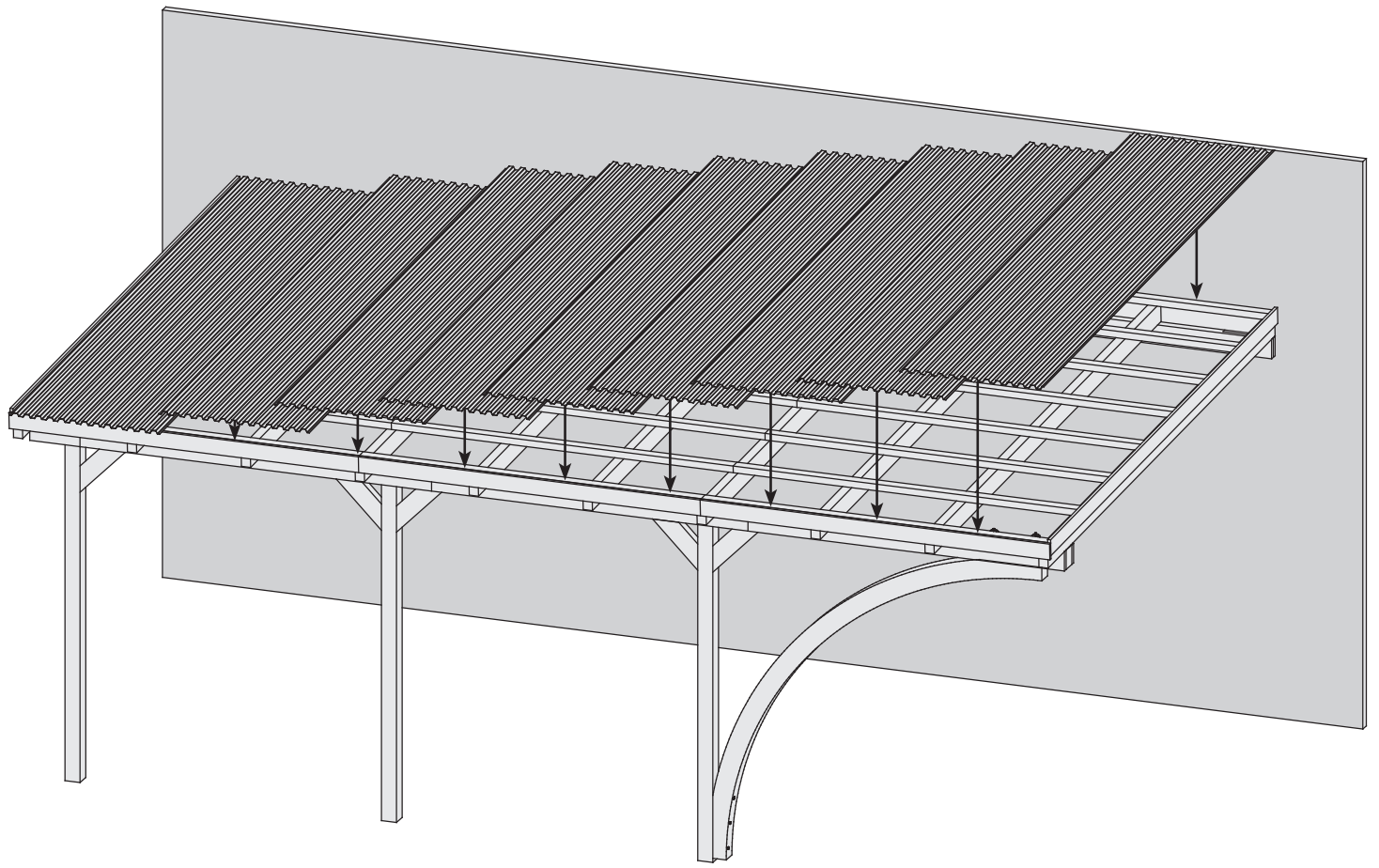

29

