

# STÜCKLISTE

## Gerätehaus „NEO“

1C, 1D, 2C, 2D, 3A, 3B, 3C, 3D, 4A, 4B, 4C, 4D

Stand August 2022 | technische Änderungen vorbehalten



Doorpackage · Carton de portes · Deurpakket · Kit de puerta · Pacco porta · Dørpakke · Dörrpaket · Dørpakke · opakowanie zawierające drzwi · Balenie dverí · Paket vrat · Balení dveří · Ajtó csomag · Paket vrata

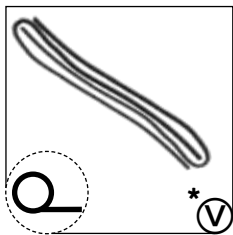
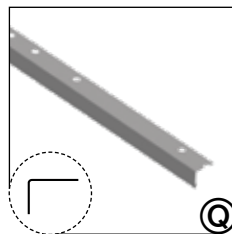
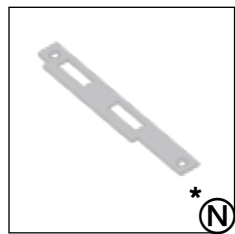
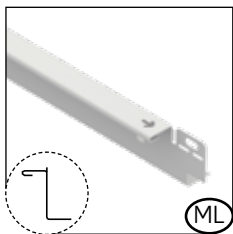
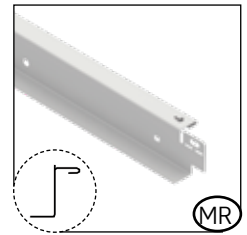
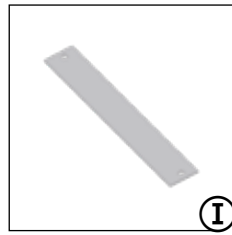
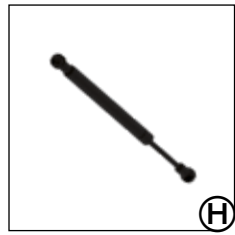
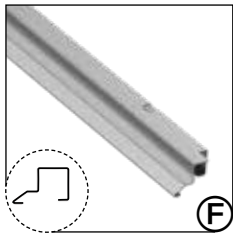
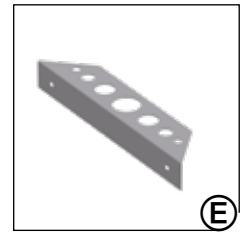
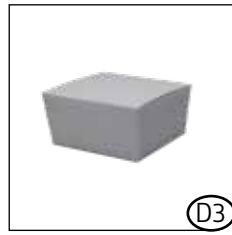
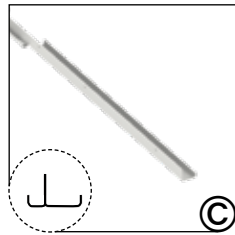
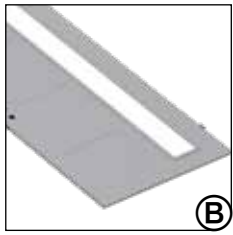

**\*TEIL ENTFÄLLT BEI DER DOPPELTÜR**

- (GB) Part not required when double doors are fitted
- (FR) La pièce est supprimée pour la double portes
- (NL) Deel vervalt bij de dubbele deur
- (ES) Pieza no es necesaria en caso de puerta doble
- (IT) Pezzo non può essere utilizzato per la variante porta a due battenti
- (DK) Del ikke nødvendig med dobbeltdør
- (SE) Den här delen utgår vid dubbel dörr
- (NO) Del er ikke nødvendig når dobbeltdør er montert
- (PL) Element nie występuje w drzwiach podwójnych
- (SK) Súčiastka nie je potrebná, ak sú namontované dvojité dvere
- (SI) Del ni potreben, če so nameščena dvojna vrata
- (CZ) Součástka není potřebná, jsou-li namontovány dvojité dveře
- (HU) Ez a tétel a duplaajtó esetén elmarad
- (HR) Rezervni ključ čuvajte odvojeno u slučaju da trebate kopirati

**ZUSATZTEILE DOPPELTÜR**

double door package · carton de double portes · dubbeldeurpakket · pacco porta doppia · kit de puerta adicional · ekstradele dobbeltdør · extra delar dubbel dörr · dobbeltdør pakke · element dodatkowy dla drzwi podwójnych · balenie dwojkřídlových dverí · paket z dvojnimi vrati · balení dvoukřídlových dveří · tartozék a dupla ajtóhoz · paket s dvostrukim vratima

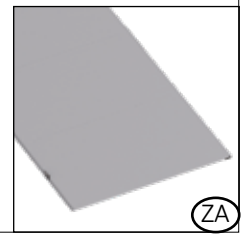

## 2 SEITENWAND - PAKET

Side panel package · Carton de parois latérales · Zijwandpakket · Panel la teral · Pacco pareti laterali · Sidepladepakke · Sidoväggspaket · Side panel pakke · opakowanie zawierające elementy ścienne · Balenie bočného panela · Paket stranske plošče · Balení bočního panelu · Oldalfal csomag · Paket bočne ploče

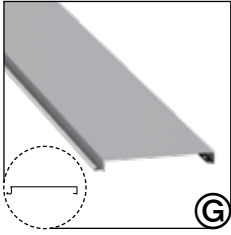

## 3 PROFIL - PAKET

Profile package · Carton de profils · Profielpakket · Kit de perfiles · Pacco profili · Profilpakke · Profilpaket · Profilpakke · opakowanie zawierające elementy profilowe · Balenie profilov · Profilni paket · Balení profilů · Profilsomag · Paket profila

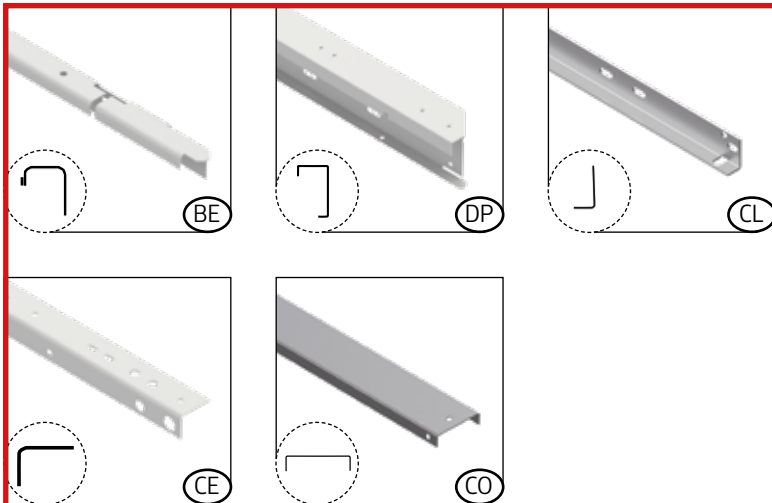
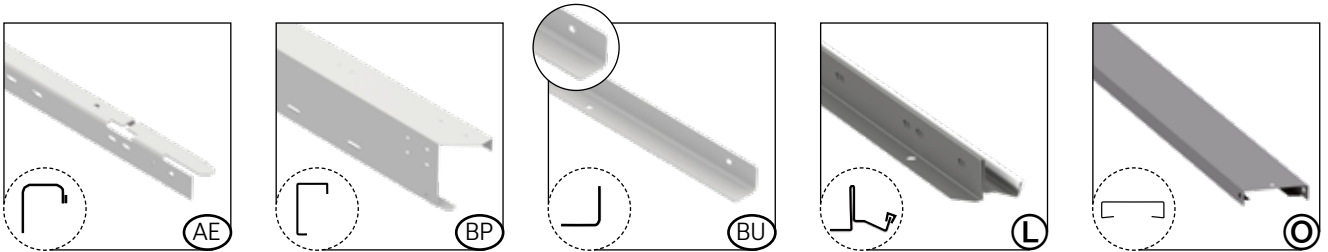

### NUR FÜR GRÖSSE 3A, 3B, 3C, 3D, 4A, 4B, 4C, 4D

- GB** Only for size 3A, 3B, 3C, 3D, 4A, 4B, 4C, 4D
- FR** Uniquement pour taille 3A, 3B, 3C, 3D, 4A, 4B, 4C, 4D
- NL** Alleen voor maat 3A, 3B, 3C, 3D, 4A, 4B, 4C, 4D
- ES** Sólo para el tamaño 3A, 3B, 3C, 3D, 4A, 4B, 4C, 4D
- IT** Solo per misura 3A, 3B, 3C, 3D, 4A, 4B, 4C, 4D
- DK** Kun for størrelse 3A, 3B, 3C, 3D, 4A, 4B, 4C, 4D
- SE** Endast för storlek 3A, 3B, 3C, 3D, 4A, 4B, 4C, 4D
- NO** Bare til str 3A, 3B, 3C, 3D, 4A, 4B, 4C, 4D
- PL** Czynność tylko dla wielkości 3A, 3B, 3C, 3D, 4A, 4B, 4C, 4D
- SK** Len pre veľ. 3A, 3B, 3C, 3D, 4A, 4B, 4C, 4D
- SI** Samo za velikosti 3A, 3B, 3C, 3D, 4A, 4B, 4C, 4D
- CZ** Pouze pro vel. 3A, 3B, 3C, 3D, 4A, 4B, 4C, 4D
- HU** Csak 3A, 3B, 3C, 3D, 4A, 4B, 4C, 4D-es mérethez
- HR** Samo za veličine 3A, 3B, 3C, 3D, 4A, 4B, 4C, 4D

Profile package · Carton de profils · Profielpakket · Kit de perfiles · Pacco profili · Profilpakke · Profilpaket · Profilpakke · opakowanie zawierające elementy profilowe · Balenie profilov · Profilni paket · Balení profilů · Profilsomag · Paket profila

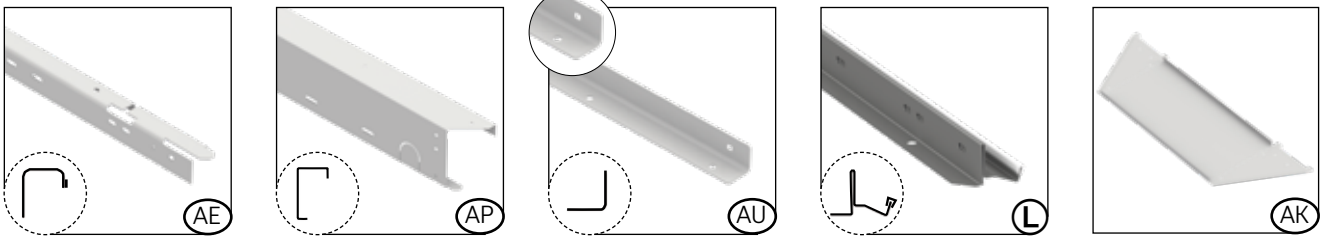

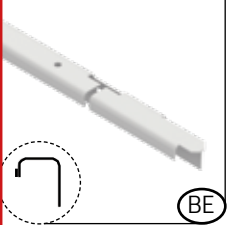
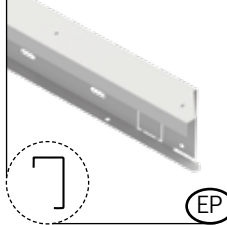
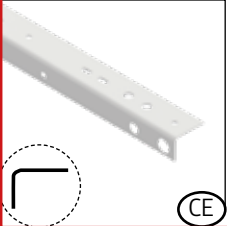
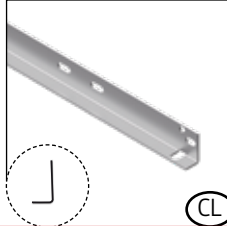
**NUR FÜR GRÖSSE 1C, 1D, 2C, 2D, 3C, 3D, 4C, 4D**

- GB** Only for size 1C, 1D, 2C, 2D, 3C, 3D, 4C, 4D
- FR** Uniquement pour taille 1C, 1D, 2C, 2D, 3C, 3D, 4C, 4D
- NL** Alleen voor maat 1C, 1D, 2C, 2D, 3C, 3D, 4C, 4D
- ES** Sólo para el tamaño 1C, 1D, 2C, 2D, 3C, 3D, 4C, 4D
- IT** Solo per misura 1C, 1D, 2C, 2D, 3C, 3D, 4C, 4D
- DK** Kun for størrelse 1C, 1D, 2C, 2D, 3C, 3D, 4C, 4D
- SE** Endast för storlek 1C, 1D, 2C, 2D, 3C, 3D, 4C, 4D
- NO** Bare til str 1C, 1D, 2C, 2D, 3C, 3D, 4C, 4D
- PL** Czynność tylko dla wielkości 1C, 1D, 2C, 2D, 3C, 3D, 4C, 4D
- SK** Len pre veľ. 1C, 1D, 2C, 2D, 3C, 3D, 4C, 4D
- SI** Samo za velikosti 1C, 1D, 2C, 2D, 3C, 3D, 4C, 4D
- CZ** Pouze pro vel. 1C, 1D, 2C, 2D, 3C, 3D, 4C, 4D
- HU** Csak 1C, 1D, 2C, 2D, 3C, 3D, 4C, 4D-es mérethez
- HR** Samo za veličine 1C, 1D, 2C, 2D, 3C, 3D, 4C, 4D



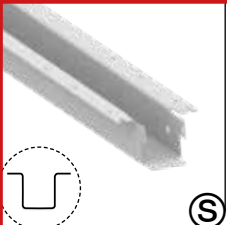

**NUR FÜR GRÖSSE 3A, 3B, 4A, 4B**

- GB** Only for size 3A, 3B, 4A, 4B
- FR** Uniquement pour taille 3A, 3B, 4A, 4B
- NL** Alleen voor maat 3A, 3B, 4A, 4B
- ES** Sólo para el tamaño 3A, 3B, 4A, 4B
- IT** Solo per misura 3A, 3B, 4A, 4B
- DK** Kun for størrelse 3A, 3B, 4A, 4B
- SE** Endast för storlek 3A, 3B, 4A, 4B
- NO** Bare til str 3A, 3B, 4A, 4B
- PL** Czynność tylko dla wielkości 3A, 3B, 4A, 4B
- SK** Len pre veľ. 3A, 3B, 4A, 4B
- SI** Samo za velikosti 3A, 3B, 4A, 4B
- CZ** Pouze pro vel. 3A, 3B, 4A, 4B
- HU** Csak 3A, 3B, 4A, 4B-es mérethez
- HR** Samo za veličine 3A, 3B, 4A, 4B

## 3b PROFIL - PAKET

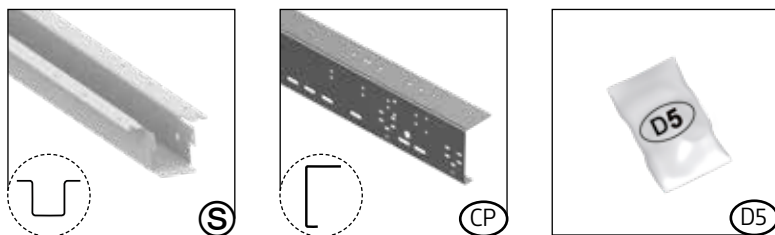
Profile package · Carton de profils · Profilpakket · Kit de perfiles · Pacco profili · Profilpakke · Profilpaket · Profilpakke · opakowanie zawierające elementy profilowe · Balenie profilov · Profilni paket · Balení profilů · Profilsomag · Paket profila





**D6**

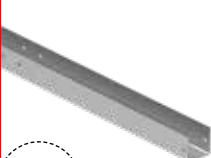

**CS**

**NUR FÜR GRÖSSE 1C, 1D, 2C, 2D, 3C, 3D, 4C, 4D**

- GB** Only for size 1C, 1D, 2C, 2D, 3C, 3D, 4C, 4D
- FR** Uniquement pour taille 1C, 1D, 2C, 2D, 3C, 3D, 4C, 4D
- NL** Alleen voor maat 1C, 1D, 2C, 2D, 3C, 3D, 4C, 4D
- ES** Sólo para el tamaño 1C, 1D, 2C, 2D, 3C, 3D, 4C, 4D
- IT** Solo per misura 1C, 1D, 2C, 2D, 3C, 3D, 4C, 4D
- DK** Kun for størrelse 1C, 1D, 2C, 2D, 3C, 3D, 4C, 4D
- SE** Endast för storlek 1C, 1D, 2C, 2D, 3C, 3D, 4C, 4D
- NO** Bare til str 1C, 1D, 2C, 2D, 3C, 3D, 4C, 4D
- PL** Czynność tylko dla wielkości 1C, 1D, 2C, 2D, 3C, 3D, 4C, 4D
- SK** Len pre veľ. 1C, 1D, 2C, 2D, 3C, 3D, 4C, 4D
- SI** Samo za velikosti 1C, 1D, 2C, 2D, 3C, 3D, 4C, 4D
- CZ** Pouze pro vel. 1C, 1D, 2C, 2D, 3C, 3D, 4C, 4D
- HU** Csak 1C, 1D, 2C, 2D, 3C, 3D, 4C, 4D-es mérethez
- HR** Samo za veličine 1C, 1D, 2C, 2D, 3C, 3D, 4C, 4D

## 4 DACH - HOLZPAKET

Roof wood package · Colis du plafond en bois · Pakket dakhout · Paquete de madera para el techo · Pacchetto di legno per il tetto · Tag trækasse · Taktråpaket · Tak pakke i tre · Pakiet drewna dachowego · Balík na strechu · Paket lesa za streho · Balíček na strechu · Fa tetőcsomag · Krovni drveni paket



## 4a DACH - HOLZPAKET

Roof wood package · Colis du plafond en bois · Pakket dakhout · Paquete de madera para el techo · Pacchetto di legno per il tetto · Tag trækasse · Takträpaket · Tak pakke i tre · Pakiet drewna dachowego · Balík na strechu · Paket lesa za streho · Balíček na strechu · Fa tetőcsomag · Krovni drveni paket



**NUR FÜR GRÖSSE 1C, 1D, 2C, 2D, 3C, 3D, 4C, 4D**

- GB** Only for size 1C, 1D, 2C, 2D, 3C, 3D, 4C, 4D
- FR** Uniquement pour taille 1C, 1D, 2C, 2D, 3C, 3D, 4C, 4D
- NL** Alleen voor maat 1C, 1D, 2C, 2D, 3C, 3D, 4C, 4D
- ES** Sólo para el tamaño 1C, 1D, 2C, 2D, 3C, 3D, 4C, 4D
- IT** Solo per misura 1C, 1D, 2C, 2D, 3C, 3D, 4C, 4D
- DK** Kun for størrelse 1C, 1D, 2C, 2D, 3C, 3D, 4C, 4D
- SE** Endast för storlek 1C, 1D, 2C, 2D, 3C, 3D, 4C, 4D
- NO** Bare til str 1C, 1D, 2C, 2D, 3C, 3D, 4C, 4D
- PL** Czynność tylko dla wielkości 1C, 1D, 2C, 2D, 3C, 3D, 4C, 4D
- SK** Len pre veľ. 1C, 1D, 2C, 2D, 3C, 3D, 4C, 4D
- SI** Samo za velikosti 1C, 1D, 2C, 2D, 3C, 3D, 4C, 4D
- CZ** Pouze pro vel. 1C, 1D, 2C, 2D, 3C, 3D, 4C, 4D
- HU** Csak 1C, 1D, 2C, 2D, 3C, 3D, 4C, 4D-es mérethez
- HR** Samo za veličine 1C, 1D, 2C, 2D, 3C, 3D, 4C, 4D

## 4b DACH - HOLZPAKET

Roof wood package · Colis du plafond en bois · Pakket dakhout · Paquete de madera para el techo · Pacchetto di legno per il tetto · Tag trækasse · Takträpaket · Tak pakke i tre · Pakiet drewna dachowego · Balík na strechu · Paket lesa za streho · Balíček na strechu · Fa tetőcsomag · Krovni drveni paket





**NUR FÜR GRÖSSE 3A, 3B, 3C, 3D, 4A, 4B, 4C, 4D**

- GB** Only for size 3A, 3B, 3C, 3D, 4A, 4B, 4C, 4D
- FR** Uniquement pour taille 3A, 3B, 3C, 3D, 4A, 4B, 4C, 4D
- NL** Alleen voor maat 3A, 3B, 3C, 3D, 4A, 4B, 4C, 4D
- ES** Sólo para el tamaño 3A, 3B, 3C, 3D, 4A, 4B, 4C, 4D
- IT** Solo per misura 3A, 3B, 3C, 3D, 4A, 4B, 4C, 4D
- DK** Kun for størrelse 3A, 3B, 3C, 3D, 4A, 4B, 4C, 4D
- SE** Endast för storlek 3A, 3B, 3C, 3D, 4A, 4B, 4C, 4D
- NO** Bare til str 3A, 3B, 3C, 3D, 4A, 4B, 4C, 4D
- PL** Czynność tylko dla wielkości 3A, 3B, 3C, 3D, 4A, 4B, 4C, 4D
- SK** Len pre veľ. 3A, 3B, 3C, 3D, 4A, 4B, 4C, 4D
- SI** Samo za velikosti 3A, 3B, 3C, 3D, 4A, 4B, 4C, 4D
- CZ** Pouze pro vel. 3A, 3B, 3C, 3D, 4A, 4B, 4C, 4D
- HU** Csak 3A, 3B, 3C, 3D, 4A, 4B, 4C, 4D-es mérethez
- HR** Samo za veličine 3A, 3B, 3C, 3D, 4A, 4B, 4C, 4D

## 5 DACH - PROFILPAKET

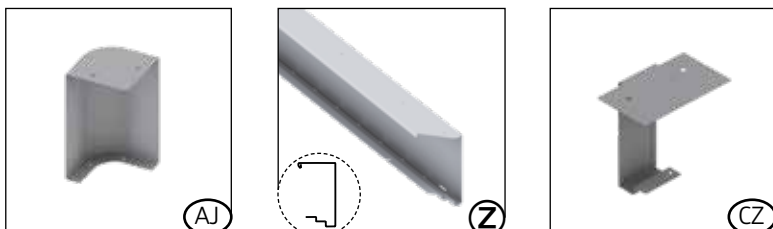
Roof profile package · Carton des profils de toit · Dakprofilpaket · Paquete de perfil de cubierta estándar · Pacco profili del tetto · Tagprofilpakke · Takprofilpaket · Takprofil pakke · Opakowanie zawierające profile dachowe · Balenie strechy · Paket strešnih profilov · Balení střechy · Szabvány tetősín csomag · Paket krovnih profila



## 6 DACH - FOLIENPAKET

Roof membrane package · Colis de la membrane en EPDM pour le toit · Dakfolie pakket · Paquete de láminas para el techo · Pacchetto di lamina per il tetto · Tag-folie pakke · Takfilmspaket · Takfolie pakke · Pakiet membran dachowych · Balík strešných fólií · Paket z membrano za streho · Balíček střešních fólií · Tetőfólia csomag · Paket folija za krov



(R)

## 7 ECKPANEEL - PAKET

Corner panel package · Colis des parois d'angle · Hoekpaneelpakket · Paquete de paneles de esquina · Pacchetto di pannelli angolari · Hjørnepanel pakke · Hörnpanelpaket · Hjørne panel pakke · Pakiet paneli narożnych · Balík rohových panelov · Paket z kotnim panelom · Balíček rohových panelů · Sarokpanel csomag · Paket kutnih ploča

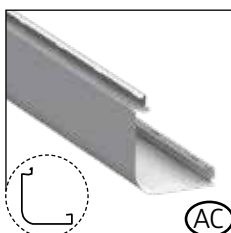

(AC)

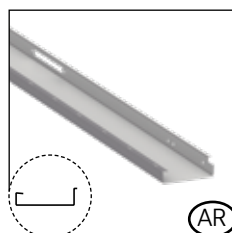

(AR)

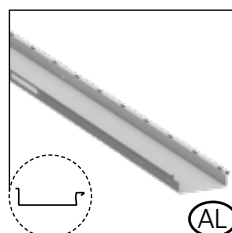

(AL)



(T)

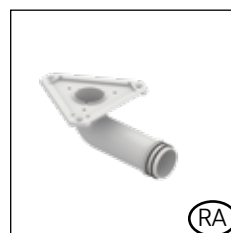

(RA)

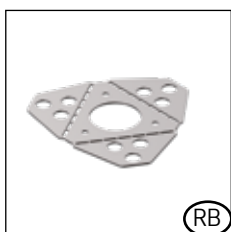

(RB)

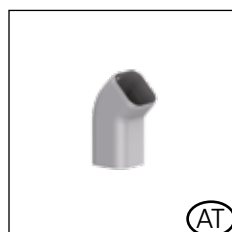

(AT)

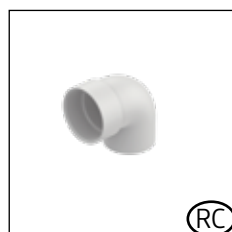

(RC)

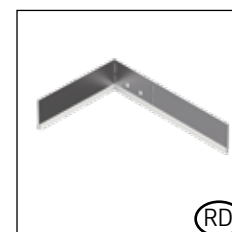

(RD)

### KLEINTEILEPAKET D2

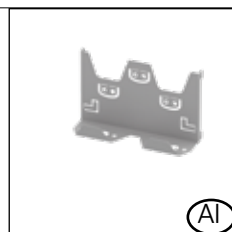

(AI)

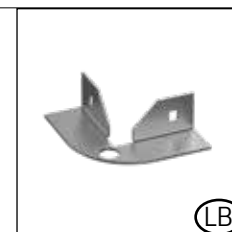

(LB)

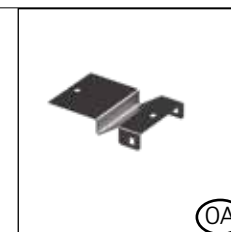

(OA)

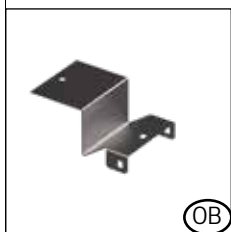

(OB)

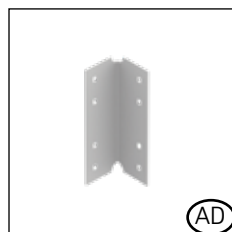

(AD)



(D1)

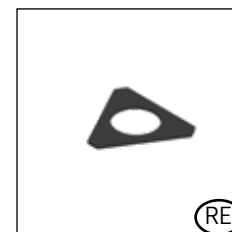

(RE)

## BODENRAHMEN - OPTIONAL

Floor frame · Cadre de sol · Bodemframe · Marco de suelo · Telaio perimetrale · Bundramme · Bottenram · Gulvramme · rama podłogowa · Podlahový rám · Podlahový rám · Talni okvir · Padlókeret · Podni okvir

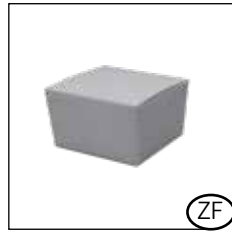
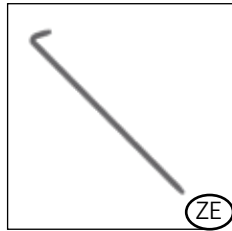
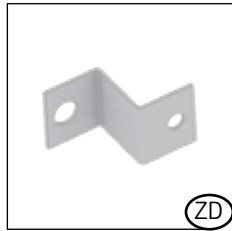
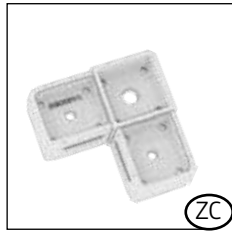

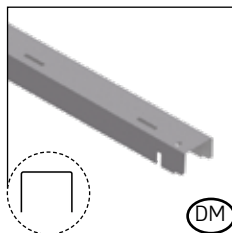
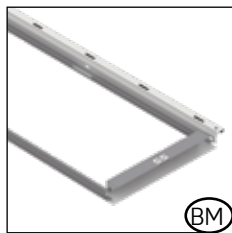
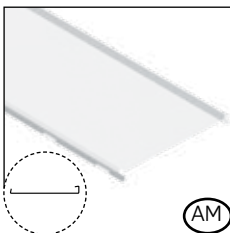

## LICHTPANEEL - OPTIONAL

Acrylic glass panel · Panneau lumineux · Lichtpaneel · Panel de luz · Elemento in vetro acrilico · Akrylglas panel · Ijuspanel · glassplatten · Panel szklany · Sklenený akrylový panel · Akrilna steklena plošča · Skleněný akrylový panel · Akrilüveg panel · Akrilna staklena ploča





Paket Nr.	Pos-Nr.	Artikel-Nummer	Maße (mm)	Artikelname	1C	1D	2C	2D	3A	3B	3C	3D	4A	4B	4C	4D
					Stk.	Stk.	Stk.	Stk.	Stk.	Stk.	Stk.	Stk.	Stk.	Stk.	Stk.	Stk.
 <b>Paket Nr. 1</b> Standardtürpaket 8#011	<b>B</b>	EN*00220	/	Tür rechts komplett	1	1	1	1	1	1	1	1	1	1	1	1
	<b>C</b>	XN601116	779	Versteifung Kopfprofil	1	1	1	1	1	1	1	1	1	1	1	1
	<b>E</b>	XN*00430	/	Werkzeughalter Glastür	2	2	2	2	2	2	2	2	2	2	2	2
	<b>F</b>	XN701106	835	Türbodenschwelle Standardtür	1	1	1	1	1	1	1	1	1	1	1	1
	<b>ML</b>	XN600111	/	Türanschlagprofil links	1	1	1	1	1	1	1	1	1	1	1	1
	<b>MR</b>	XN600110	/	Türanschlagprofil rechts	1	1	1	1	1	1	1	1	1	1	1	1
	<b>Q</b>	XN*01109	880	Abdeckleiste Kopfprofil Standardtür	1	1	1	1	1	1	1	1	1	1	1	1
	<b>V</b>	XN702134	2000	Gummiprofil	1	1	1	1	1	1	1	1	1	1	1	1
		<b>XH780011</b>	/	Kleinteilepaket für Standardtür	1	1	1	1	1	1	1	1	1	1	1	1
	<b>D3</b>	XH700241	/	Türdrückergarnitur	1	1	1	1	1	1	1	1	1	1	1	1
	<b>D4</b>	XH700547	/	Schrauben und Kleinteilepackchen für Standardtür	1	1	1	1	1	1	1	1	1	1	1	1
	<b>H</b>	X3000224	/	Gasdruckfeder 75N	1	1	1	1	1	1	1	1	1	1	1	1
	<b>I</b>	XH700248	/	Abdeckblech f. Türanschlagprofil	1	1	1	1	1	1	1	1	1	1	1	1
	<b>J</b>	E3000227	/	Gasfederkonsole für Tür	1	1	1	1	1	1	1	1	1	1	1	1
<b>N</b>	XH700246	/	Schließblech für Tür rechts	1	1	1	1	1	1	1	1	1	1	1	1	
<b>-</b>	XH700245	/	Profizylinder mit Schlüssel	1	1	1	1	1	1	1	1	1	1	1	1	

Paket Nr.	Pos-Nr.	Artikel-Nummer	Maße (mm)	Artikelname	1C	1D	2C	2D	3A	3B	3C	3D	4A	4B	4C	4D
					Stk.	Stk.	Stk.	Stk.	Stk.	Stk.	Stk.	Stk.	Stk.	Stk.	Stk.	Stk.
 <b>Paket Nr. 1</b> Doppeltürpaket 8#021	<b>B</b>	EN*00220	/	Tür rechts komplett	1	1	1	1	-	1	1	1	-	1	1	1
	<b>C</b>	XN602116	1619	Versteifung Kopfprofil	1	1	1	1	-	1	1	1	-	1	1	1
	<b>E</b>	XN*00430	/	Werkzeughalter Glastür	2	2	2	2	-	2	2	2	-	2	2	2
	<b>F</b>	XN702106	1675	Türbodenschwelle Doppeltür	1	1	1	1	-	1	1	1	-	1	1	1
	<b>ML</b>	XN600111	/	Türanschlagprofil links	1	1	1	1	-	1	1	1	-	1	1	1
	<b>MR</b>	XN600110	/	Türanschlagprofil rechts	1	1	1	1	-	1	1	1	-	1	1	1
	<b>Q</b>	XN*02109	1720	Abdeckleiste Kopfprofil Doppeltür	1	1	1	1	-	1	1	1	-	1	1	1
	<b>ZA</b>	EN*00240	/	Tür links komplett	1	1	1	1	-	1	1	1	-	1	1	1
		<b>XH780021</b>	/	Kleinteilepaket für Doppeltür	1	1	1	1	-	1	1	1	-	1	1	1
	<b>D3</b>	XH700241	/	Türdrückergarnitur	1	1	1	1	-	1	1	1	-	1	1	1
	<b>D4</b>	XH700548	/	Schrauben und Kleinteilepaket für Doppeltür	1	1	1	1	-	1	1	1	-	1	1	1
	<b>H</b>	X3000224	/	Gasdruckfeder 75N	2	2	2	2	-	2	2	2	-	2	2	2
	<b>I</b>	XH700248	/	Abdeckblech für Türanschlagprofil	2	2	2	2	-	2	2	2	-	2	2	2
	<b>J</b>	E3000227	/	Gasfederkonsole für Tür	2	2	2	2	-	2	2	2	-	2	2	2
<b>K</b>	EH700250	/	Drehknopf innen mit Rosette	1	1	1	1	-	1	1	1	-	1	1	1	
<b>-</b>	XH700245	/	Profizylinder mit Schlüssel	1	1	1	1	-	1	1	1	-	1	1	1	



3a

					1C	1D	2C	2D	3A	3B	3C	3D	4A	4B	4C	4D
<b>AE</b>	EN601107	1661	Kopprofil beklebt GHN Gr. 1 (Vormontage X0001008)		-	-	-	-	2	-	-	-	2	-	-	-
	EN602107	2221	Kopprofil beklebt GHN Gr. 2 (Vormontage X0001008)		-	-	-	-	-	2	-	-	-	2	-	-
	EN603107	1390,5	Kopprofil beklebt GHN Gr. 3 links (Vormontage X00010008)		2	-	2	-	-	-	2	-	-	-	2	-
	EN604107	1670,5	Kopprofil beklebt GHN Gr. 4 links (Vormontage X00010008)		-	2	-	2	-	-	-	2	-	-	-	2
	EN603106	1390,5	Kopprofil beklebt GHN Gr. 3 rechts (Vormontage X00010008)		2	-	2	-	-	-	2	-	-	-	2	-
<b>BE</b>	EN604106	1670,5	Kopprofil beklebt GHN Gr. 4 rechts (Vormontage X00010008)		-	2	-	2	-	-	-	2	-	-	-	2
	XI604402	/	Regalboden		2	2	2	2	2	2	2	2	2	2	2	2
<b>L</b>	EN701104	1631	Bodenprofil montiert GHN Gr. 1 (Vormontage XN701110)		-	-	-	-	2	-	-	-	2	-	-	-
	EN702104	2191	Bodenprofil montiert GHN Gr. 2 (Vormontage XN702110)		-	-	-	-	-	2	-	-	-	2	-	-
	EN703104	1375,5	Bodenprofil montiert GHN Gr. 3 (Vormontage XN703110)		4	-	4	-	-	-	4	-	-	-	4	-
	EN704104	1655,5	Bodenprofil montiert GHN Gr. 4 (Vormontage XN704110)		-	4	-	4	-	-	-	4	-	-	-	4
	XN601324	1717	Dachauflage GHN Gr. A		-	-	-	-	2	-	-	-	2	-	-	-
<b>AP</b>	XN602324	2277	Dachauflage GHN Gr. B		-	-	-	-	-	2	-	-	-	2	-	-
	XN603323	1418,3	Dachauflage GHN Gr. C links		2	-	2	-	-	-	2	-	-	-	2	-
	XN604323	1698,3	Dachauflage GHN Gr. D links		-	2	-	2	-	-	-	2	-	-	-	2
	XN603324	1418,3	Dachauflage GHN Gr. C rechts		2	-	2	-	-	-	2	-	-	-	2	-
	XN604324	1698,3	Dachauflage GHN Gr. D rechts		-	2	-	2	-	-	-	2	-	-	-	2
<b>S</b>	XN601328	1690	Dachträger GHN Gr. A		-	-	-	-	2	-	-	-	2	-	-	-
	XN602328	2250	Dachträger GHN Gr. B		-	-	-	-	-	2	-	-	-	2	-	-
<b>AU</b>	XN601327	1619	Holzauflegewinkel GHN Gr. A		-	-	-	-	2	-	-	-	2	-	-	-
	XN602327	2179	Holzauflegewinkel GHN Gr. B		-	-	-	-	-	2	-	-	-	2	-	-
	XN603327	1369,5	Holzauflegewinkel GHN Gr. C		4	-	4	-	-	-	4	-	-	-	4	-
	XN604327	1649,5	Holzauflegewinkel GHN Gr. D		-	4	-	4	-	-	-	4	-	-	-	4
<b>CE</b>	XN601115	520	Kopprofil Versteifung		2	2	2	2	-	-	2	2	-	-	2	2
	XN700104	890	Versteifung Bodenprofil		2	2	2	2	-	-	2	2	-	-	2	2

Paket Nr. 3a

Profilpaket Breite

80113 (3A/4A)

80123 (3B/4B)

80133 (1C/2C/3C/4C/)

80143 (1D/2D/3D/4D/)

3b

					1C	1D	2C	2D	3A	3B	3C	3D	4A	4B	4C	4D
<b>S</b>	XN601328	1690	Dachträger GHN Gr. A		-	-	-	-	2	-	-	-	2	-	-	-
	XN602328	2250	Dachträger GHN Gr. B		-	-	-	-	-	2	-	-	-	2	-	-
	XN603328	1404,7	Dachträger GHN Gr. C		4	-	4	-	-	-	4	-	-	-	4	-
	XN604328	1617,4	Dachträger GHN Gr. D		-	4	-	4	-	-	-	4	-	-	-	4
<b>CP</b>	EN603106	2000	Dachauflage Versteifung		2	2	2	2	2	2	2	2	2	2	2	2
	XN700554	/	Schraubenpaket Größenerweiterung		1	1	1	1	1	1	1	1	1	1	1	1
<b>CS</b>	XN700328	1025	Dachträger Versteifung		2	2	2	2	-	-	2	2	-	-	2	2
	XN700555	/	Schraubenpaket Größenerw. Dachträger		1	1	1	1	-	-	1	1	-	-	1	1

80115 (3A/4A)

80125 (3B/4B)

80135 (1C/2C/3C/4C)

80145 (1D/2D/3D/4D)

4

Paket Nr. 4		1C	1D	2C	2D	3A	3B	3C	3D	4A	4B	4C	4D	
Dach-Holzpaket 80014 (1C) 80024 (1D)	W	XN701303	1624											
		XN702303	2184	1										
		XN703301	1620			1	1	1	1					
		XN704301	1989								1	1	1	1
80054 (2C) 80064 (2D) 80074 (3A/3C) 80084 (3B/3D)	X	XN701300	1624	2	3									
		XN702300	2184		2	3								
		XN703300	1620				2	3	2	3				
		XN704300	1989									2	3	2
80094 (4A/4C) 80004(4B/4D)	Y	XN701304	1624	1	1									
		XN702304	2184		1	1								
		XN703302	1620				1	1	1	1				
		XN704302	1989								1	1	1	1

4a

Paket Nr. 4		1C	1D	2C	2D	3A	3B	3C	3D	4A	4B	4C	4D	
Dach-Holzpaket 80034 (1C/1D) 80044 (2C/2D) 80274 (3C/3D) 80294 (4C/4D)	X	XN701300	1624	2	2									
		XN702300	2184		2	2								
		XN703300	1620					2	2	2				
		XN713300	1120						2	2				
		XN704300	1989										2	2
		XN714300	1314									2	2	

4b

Paket Nr. 4		1C	1D	2C	2D	3A	3B	3C	3D	4A	4B	4C	4D
Dach-Holzpaket 80174 (3A/3C) 80184 (3B/3D)	X	XN713300	1120			2	3	2	3				
		XN714300	1314							2	3	2	3
80194 (4A/4C) 80104 (4B/4D)	AX	XN713301	1120			2	2	2	2				
		XN714301	1314							2	2	2	2

5

Paket Nr. 5		1C	1D	2C	2D	3A	3B	3C	3D	4A	4B	4C	4D
Dach-Profilpaket 8#015 (Gr. 1/A) 8#025 (Gr. 2/B)	AJ	XN*00311	/	4	4	4	4	4	4	4	4	4	4
	CZ	XN*02711	/	2	2	2	2	2	2	2	2	2	2
8#035 (Gr. 3/C) 8#045 (Gr. 4/D)	Z	XN*01308	1737	2	2								
		XN*02308	2297			2	2				2		
		XN*03308	1426,9	4		4		4	4	4			4
		XN*04308	1706,9		4				4			4	4

6

		1C	1D	2C	2D	3A	3B	3C	3D	4A	4B	4C	4D
<b>Paket Nr.6</b> Dach-Folienpaket 80046 (1C/3A) 80056 (2C/3B) 80066 (1D/4A) 80076 (2D/4B) 80086 (3D/4C) 80096 (3C) 80006 (4D)		80046	/			1	-	-	-	-	-	-	-
		80056	/	1	-	-	1	-	-	-	-	-	-
		80066	/	-	-	-	-	-	-	1	-	-	-
		80076	/	-	1	-	-	-	-	-	1	-	-
		80086	/	-	-	-	-	-	1	-	-	1	-
		80096	/	-	-	-	-	-	-	-	-	-	-
		80006	/	-	-	-	-	-	-	-	-	-	1

7

		1C	1D	2C	2D	3A	3B	3C	3D	4A	4B	4C	4D
<b>Paket Nr. 7</b> Eckpaneelpaket 81099 85099 87099	<b>AC</b>	XN*00102	/			4	4	4	4	4	4	4	4
	<b>AL</b>	XN*00105	/			1	1	1	1	1	1	1	1
	<b>AR</b>	XN*00104	/			1	1	1	1	1	1	1	1
		X4800460	/			1	1	1	1	1	1	1	1
	<b>T</b>	EN*00410	/			2	2	2	2	2	2	2	2
	<b>AT</b>	X4*00422	/			2	2	2	2	2	2	2	2
		XN700581	/			1	1	1	1	1	1	1	1
	<b>D2</b>	XN700580	/			1	1	1	1	1	1	1	1
	<b>AD</b>	XN600321	/			4	4	4	4	4	4	4	4
		XN700550	/			1	1	1	1	1	1	1	1
	<b>AI</b>	XI604425	/			2	2	2	2	2	2	2	2
	<b>LB</b>	XN700322	/			4	4	4	4	4	4	4	4
	<b>OA</b>	XN700430	/			3	3	3	3	3	3	3	3
	<b>D1</b>	XN700551	/			1	1	1	1	1	1	1	1
<b>OB</b>	XN700431	/			3	3	3	3	3	3	3	3	

Farbe Auswahl Artikelnummer (gilt nicht für Verkaufartikelnummer)

silber-metallic \* ..... → 3 .....

dunkelgrau-metallic \* ..... → 4 .....

quarzgrau-metallic \* ..... → 8 .....

# ... → 1 ....

# ... → 5 ....

# ... → 7 ....



			1C	1D	2C	2D	3A	3B	3C	3D	4A	4B	4C	4D
<b>Lichtpaneel</b> 470#4	<b>AM</b>	XI700434			Lichtpaneel			1	1	1	1	1	1	1
	<b>BM</b>	EI*00435			Rahmenprofil links			1	1	1	1	1	1	1
	<b>CM</b>	EI*00436			Rahmenprofil rechts			1	1	1	1	1	1	1
	<b>EM</b>	EI*00432			Rahmenprofil oben			1	1	1	1	1	1	1
	<b>FM</b>	EI*00433			Rahmenprofil unten			1	1	1	1	1	1	1
	<b>DM</b>	XI*00437			Abdeckleiste			2	2	2	2	2	2	2
	<b>GM</b>	XI700456			Schraubenpaket Lichtpaneel			1	1	1	1	1	1	1

Paket-Nr.	Artikel-Nummer	Artikelname	1C	1D	2C	2D	3A	3B	3C	3D	4A	4B	4C	4D
<b>Schraubenpaket</b> XI700456	A52002	Flachrundschrabe M5x10	7	7	7	7	7	7	7	7	7	7	7	7
	A2000033	Mutter M5	7	7	7	7	7	7	7	7	7	7	7	7
	A4001005	Schnappmutter	4	4	4	4	4	4	4	4	4	4	4	4
	A4002019	Sechskant Blechschrabe 4,8x19	8	8	8	8	8	8	8	8	8	8	8	8
	A2000025	Beilagscheibe	15	15	15	15	15	15	15	15	15	15	15	15

Paket Nr.	Artikel-Nummer	Artikelname	Stk.
<b>Kleinteilepäckchen</b> XN700550	<b>1C, 1D, 2C, 2D, 3A, 3B, 3C, 3D, 4A, 4B, 4C, 4D</b>		
	X2000065	Steckschlüssel SW8 mit blauen Griff	1
	X2000064	Gabeschlüssel SW8	1
	A52012	Drahtstift 5x140mm	1
	A52076	Sechskant Holzschraube 8x60mm	16
	A55007	Beilagscheibe	16
	A51050	Dübel schwarz	16
	X3000419	Abdeckkappen	50
	Y1000006	Schlüsselanhänger	1
	X2000040	Handschuhe	1
	XI700403	Sicherungsteil Regalboden u. Wandschiene	4
	ZW020010	Kapselheber	1
	X2000070	Torx-Biteinsatz TX25	1

Paket Nr.	Artikel-Nummer	Artikelname	Stk.
<b>Schraubenpaket GHN</b> XN700551	<b>1C, 1D, 2C, 2D, 3A, 3B, 3C, 3D, 4A, 4B, 4C, 4D</b>		
	A52002	Flachrundschrabe M5x10	200
	A52004	Flachrundschrabe M5x18	20
	A2000033	Mutter M5	220
	A2000025	Beilagscheibe M5	240
	A4002019	Sechskant Blechschrabe 4,8x19	68
	A4005006	Nirodichtscheibe	32
	A4002011	Niroblechschrabe Kreuzschlitz 3,9x13	10
	A4003019	Halbrundkopfschrabe 5x20, TX25	55
	A2000035	Käfigmutter M5	14
	A2000028	Beilagscheibe 6,4x12x1,6	3
	A51043	Sechskant Blechschrabe 6,3x22	3
	A51017	Sechskantschrabe M5x16	14

Paket Nr.	1C, 1D, 2C, 2D, 3A, 3B, 3C, 3D, 4A, 4B, 4C, 4D		
	Artikel-Nummer	Artikelname	Stk.
<b>RE</b> Kleinteilepaket Gully XN700581	XN700429	Dichtung Dachgully	2
	A4002004	Niroblechschraube 4,8x13	10
	A4003020	Senkblechschrauben 4,8x13	8
	XN600428	Dachgully	2
	XN600429	Bogen Dachgully GHN	2
	XN700427	Laubfang Dachgully	2
	EN700311	Eckwinkel Dachfolie	2
	XB706209	Gummipuffer mit Zapfen	2

Paket Nr.	Standard-tür			Doppel-tür		
	Artikel-Nummer	Artikelname	Stk.	Stk.	Stk.	Stk.
<b>D4</b> Schrauben und Kleinteilepaket für ST / DT XH700547 / XH700458	A4003026	Senkschraube mit Kreuzschlitz M5x12	2	2	-	-
	A52002	Flachrundschraube M5x10	20	22	22	22
	A2000033	Mutter M5	22	22	22	22
	A2000025	Beilagscheibe	28	28	36	36
	A4002017	Sechskant Blechschraube	6	6	14	14
	X3000203	Edelstahlscharnier "A" männlich	1	1	2	2
	X3000204	Edelstahlscharnier "B" männlich	1	1	2	2
	X2700225	Kugelbolzen M8	1	1	2	2
	A4001007	Federring	1	1	2	2
	A54009	Sechskantmutter M8	1	1	2	2

Paket Nr.	1C, 1D, 2C, 2D, 3A, 3B, 3C, 3D, 4A, 4B, 4C, 4D		
	Artikel-Nummer	Artikelname	Stk.
<b>D5</b> Schraubenpaket Größenerweiterung XN700554	A52002	Flachrundschraube 5x10	90
	A2000033	Mutter Niro M5	100
	A4003019	Halbrundkopfschrauben A2, 5x20 TX25	80
	A2000025	Beilagscheibe 5,3x10	110
	A4005017	Beilagscheibe 5,5x18x2	24
	A51017	Sechskantschraube Niro 5x16	20
	A2000035	Käfigmutter M5 Niro	20
	A52004	Flachrundschraube 5x18	10
	A4005006	Niroblechschraube DM 5,3x14	10
	A4002019	Sechskant Blechschraube A2 4,8x19	10
	A4002011	Niroblechschraube Kreuzschlitz 3,9x13	10
	XB706209	Gummipuffer mit Zapfen	2

Paket Nr.	1C, 1D, 2C, 2D, 3A, 3B, 3C, 3D, 4A, 4B, 4C, 4D		
	Artikel-Nummer	Artikelname	Stk.
<b>D6</b> Schraubenpaket Größenerweiterung Dachträger XN700555	A4003024	Torbandschraube M8x16 A2	30
	A4003033	Sperrzahnmutter mit Flansch M8 VZ	30



