

AUFBAUANLEITUNG „SmartBase“

- Ⓜ GB Assembly manual for “SmartBase”
- Ⓜ FR Notice de montage pour “SmartBase”
- Ⓜ NL Opbouwbeschrijving “SmartBase”
- Ⓜ ES Instrucciones de montaje “SmartBase”
- Ⓜ IT Istruzioni di montaggio “SmartBase”
- Ⓜ DK Monteringsvejledning for “SmartBase”

For further languages please go to: www.biohort.com/downloads



QUALITÄT AUS
ÖSTERREICH

WICHTIGE PUNKTE FÜR DEN AUFBAU!

VORLIEGENDE AUFBAUANLEITUNG ZEIGT DEN ZUSAMMENBAU FÜR EIN „SMARTBASE“ GRÖSSE „HIGHLINE®“ H3. DEN PLAN FÜR IHRE FUNDAMENTGRÖSSE FINDEN SIE AB SEITE 6. FÜR EINIGE MONTAGESCHRITTE BENÖTIGEN SIE EINEN HELFER.

- GB** Important details regarding assembly! This assembly manual shows the installation of the „SmartBase“ for „HighLine®“ size H3. You find the plan for your foundation size from page 6. For several assembly steps additional assistance of one person will be required.
- FR** Points importants lors du montage! Cette notice de montage décrit l'assemblage de „SmartBase“ pour un „HighLine®“ H3. Vous trouverez le plan pour les dimensions de votre fondation à partir de la page 6. Pour certaines étapes, demandez l'aide d'une personne.
- NL** Belangrijke punten voor de montage! Deze montage instructies hebben betrekking op de opbouw van het SmartBase voor een „Highline®“ H3. De plattegrond voor uw fundamentgrootte vindt u op pag. 6. Voor enkele montagestappen heeft u 1 persoon nodig om u te helpen.
- ES** Notas importantes para el montaje: en estas instrucciones se muestra el montaje de los „SmartBase“ de la caseta „HighLine®“ H3. A partir de la página 6 encontrará el plano correspondiente al tamaño de sus cimientos. Es recomendable realizar algunos pasos del montaje con la ayuda de otra persona.
- IT** Indicazioni importanti per il montaggio! Le seguenti istruzioni di montaggio mostrano l'assemblaggio della „SmartBase“ di ancoraggio a terra per un „HighLine®“ dalla misura H3. A partire dalla pagina 6 trovate il prospetto per le misure della vostra fondazione. Per alcune fasi del montaggio sarà necessario essere aiutati.
- DK** Den følgende monteringsvejledning viser opbygningen af en „SmartBase“ med jordspyd til et „HighLine®“ H3. Opgivelserne om fundamentets dimensioner finder du fra side 6. Du får brug for en hjælper til dele af monteringsarbejdet.

VERWENDEN SIE BEI DER MONTAGE ARBEITSHANDSCHUHE! UM KRATZER ZU VERMEIDEN, VERWENDEN SIE BITTE GEEIGNETE UNTERLAGEN!



- GB** Wear working gloves! Please use a suitable underlay to avoid scratches!
- FR** Portez des gants de travail! Pour éviter les rayures, utilisez les supports appropriés!
- NL** Handschoenen gebruiken! Om krassen te voorkomen raden wij u aan er iets onder te leggen!
- ES** Utilice unos guantes de trabajo. Por favor, coloque en el suelo una base protectora adecuada para evitar posibles arañazos.
- IT** Utilizzare guanti da lavoro. Utilizzare una base adatta per evitare graffi!
- DK** Brug arbejdshandsker! Benyt venligst et passende underlag for at undgå skrammer!

UMGANG MIT BESCHÄDIGTEN TEILEN

Verbauen Sie keine beschädigten Teile! Falls Sie Beschädigungen feststellen, müssen diese vorab inkl. aussagekräftiger Bilder an uns gemeldet werden. Durch den Verbau gelten die Teile als akzeptiert.

- GB** Handling of damaged parts: Do not install damaged parts! If you note damages, they must be reported to us in advance, including suitable pictures. The parts are considered accepted by the installation.
- FR** Manipulation des pièces endommagées: N'installez pas de pièces endommagées ! Si vous découvrez des dommages, vous devez nous en informer à l'avance, en nous envoyant des photos significatives. Après le montage, les pièces sont considérées comme acceptées.
- NL** Omgaan met beschadigde onderdelen: Monteer géén beschadigde onderdelen! Als u schade ontdekt, moet dit vooraf aan ons worden gemeld, inclusief duidelijke foto's. Als u de beschadigde onderdelen toch monteert, dan heeft u hiermee het product "geaccepteerd".
- ES** Manejo de partes dañadas: Por favor, NO instale partes dañadas, Si descubre algún daño, debe informarnos con antelación, incluyendo fotos claras de los daños. Las piezas se consideran aceptadas si se realiza su la instalación.
- IT** Gestione di parti danneggiate: Non installare parti danneggiate! Se si rivela un danno, questo deve essere segnalato in anticipo per mail con materiale fotografico a supporto del reclamo. Se si procede all'installazione delle parti danneggiate, Biohort si riserva il diritto di respingere il reclamo.
- DK** Håndtering af beskadigede dele: Brug ikke beskadigede dele! Hvis du opdager nogen skade, skal dette rapporteres til os på forhånd, herunder meningsfulde billeder. Dele betragtes som accepteret gennem installationen.

FÜR DIE MONTAGE WERDEN MINDESTENS 50 CM PLATZ RUND UM DAS FUNDAMENT BENÖTIGT!

- GB** At least 50 cm space around the foundation is required for installation.
- FR** Un espace d'au moins 50 cm autour de la fondation est nécessaire pour le montage.
- NL** Voor de montage is ten minste 50 cm ruimte rond de fundering nodig.
- ES** Se requiere un espacio de al menos 50 cm alrededor de los cimientos para su instalación.
- IT** Per l'installazione sono necessari almeno 50 cm di spazio intorno alla fondazione.
- DK** For montage kræves yderligere 50cm plads omkring fundamentet

HALTEN SIE WÄHREND DES ZUSAMMENBAUS ALLE MITGELIEFERTEN KLEINTEILE

ODER VERPACKUNGSMATERIALIEN FERN VON KLEINKINDERN. Bauteile weisen scharfe Kanten auf oder stehen vor, achten Sie während der Montage und bei der täglichen Nutzung darauf.

- (GB)** Keep all supplied small parts or packaging materials away from small children during assembly. Components have sharp edges or protrude, pay attention to them during assembly and during daily use.
- (FR)** Gardez toutes les petites pièces ou les matériaux d'emballage fournis hors de portée des enfants pendant le montage. Les pièces d'assemblage peuvent être tranchantes, faites-y attention lors de l'assemblage et de l'utilisation quotidienne.
- (NL)** Houd alle kleine onderdelen of verpakkingsmaterialen die worden mee geleverd uit de buurt van kleine kinderen tijdens de montage. Onderdelen hebben scherpe randen of steken uit, let op bij de montage en bij het dagelijks gebruik.
- (ES)** Mantenga todas las piezas pequeñas o materiales de embalaje suministrados lejos de los niños durante el montaje. Los componentes tienen bordes afilados o salientes, preste atención a ellos durante el montaje y durante el uso diario.
- (IT)** Tenere tutte le piccole parti o i materiali d'imballaggio forniti lontano dalla portata dei bambini durante il montaggio. I componenti hanno spigoli vivi o sporgenti, prestare attenzione ad essi durante il montaggio e durante l'uso quotidiano.
- (DK)** Hold alle leverede smådele og emballage utilgængeligt for børn under montagen. Komponenter har skarpe kanter eller stikker ud, vær opmærksom på dem under montering og under daglig brug.

FOLGENDES WERKZEUG WIRD BENÖTIGT

Akkuschrauber - Wasserwaage - Gabelschlüssel SW 24 und 13

- (GB)** Following tools are needed: Shovel - Spirit level - Open end spanner SW 24 and 13
- (FR)** Outils supplémentaires requis: Pelle - Niveau à bulle - Clé de 24 et 13
- (NL)** Volgend gereedschap heeft u nodig: Schop - Waterpas - Steeksleutel SW 24 en 13
- (ES)** Necesitará las herramientas siguientes: Pala - Nivel de agua - Llaves de boca SW 24 y 13
- (IT)** Attrezzi necessari: Pala - Vivella a bolla - Chiave fissa SW 24 e 13
- (DK)** Volgend gereedschap heeft u nodig: Skovl - Vatterpas - Gaffelnøgler, SW 24 og 13

MASSTABSGETREUE ABBILDUNGEN DER ZU VERWENDENDEN SCHRAUBEN:

- (GB)** Scale drawing 1:1 of the screws in use
- (FR)** Reproduction selon l'échelle 1:1.
- (NL)** Afbeelding : schaal 1:1 (ware grootte)
- (ES)** Reproducción a escala 1:1 de los tornillos que se utilizan para el montaje.
- (IT)** Immagine in scala delle viti da utilizzare!
- (DK)** Skala tegning af skruer er 1:1

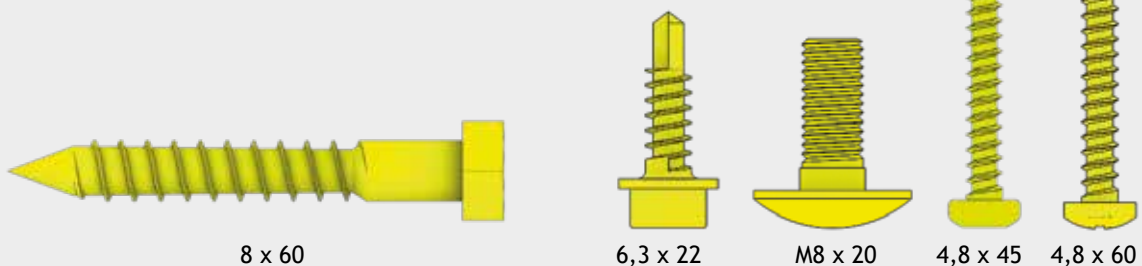

WASSERWAAGEN - SYMBOL: Betreffendes Einbauteil mit der Wasserwaage ausrichten.

- (GB)** Symbol of spirit level: Align the respective parts by using the spirit level.
- (FR)** Symbole niveau à bulle: Lorsque ce symbole apparaît, vous devez ajuster l'élément à l'aide d'un niveau à bulle.
- (NL)** Waterpas – symbol: Bij montagestappen waar dit symbool bijstaat is het noodzakelijk het betreffende onderdeel waterpas in te bouwen.
- (ES)** Símbolo del nivelador: Indica que se debe ajustar y centrar la pieza con la ayuda de un nivelador.
- (IT)** Simbolo di livella a bolla d'aria: Allineare il componente in questione con l'ausilio di una livella a bolla d'aria.
- (DK)** Symbol for vatterpas: Juster de respektive dele ved hjælp af vatterpas.

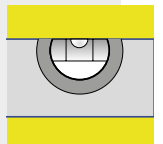



EUROPA

1



GERÄTESCHRANK

90, 150



PROFIL - STELLFUSSPAKET

Profile adjustable foot package · Colis des pieds réglables · Verstelbare voet – profiel · Perfil - Paquete de pies ajustables · Pacchetto base del profilo · Profil justerbare fødder pakke

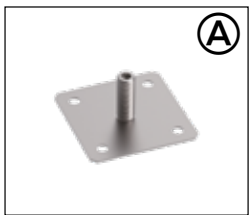

A

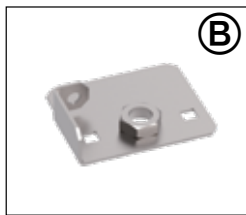

B

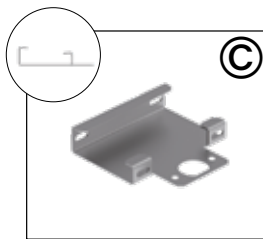

C



D

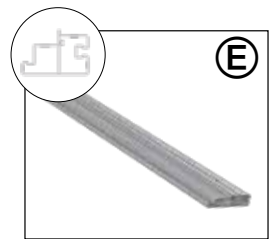

E

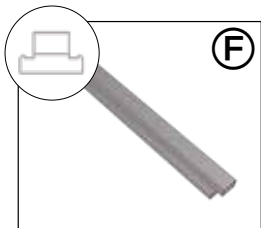

F

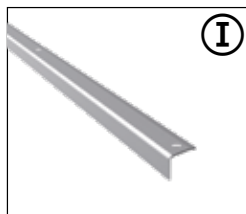

I



U

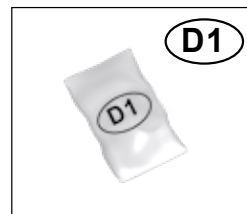

D1



DIELEN - PAKET

Floorboards package · Colis de lames · Plankenpakket · Pacco tavole per pavimento · Paquete de tablas de suelo · Gulvpakke



H



1 STELLFUSS - PAKET

Adjustable foot package · Colis profilés des pieds réglables · Pakket verstelbare voet · Paquete de pies ajustables · Pacchetto piedini regolabili · Justerbare fødder pakke

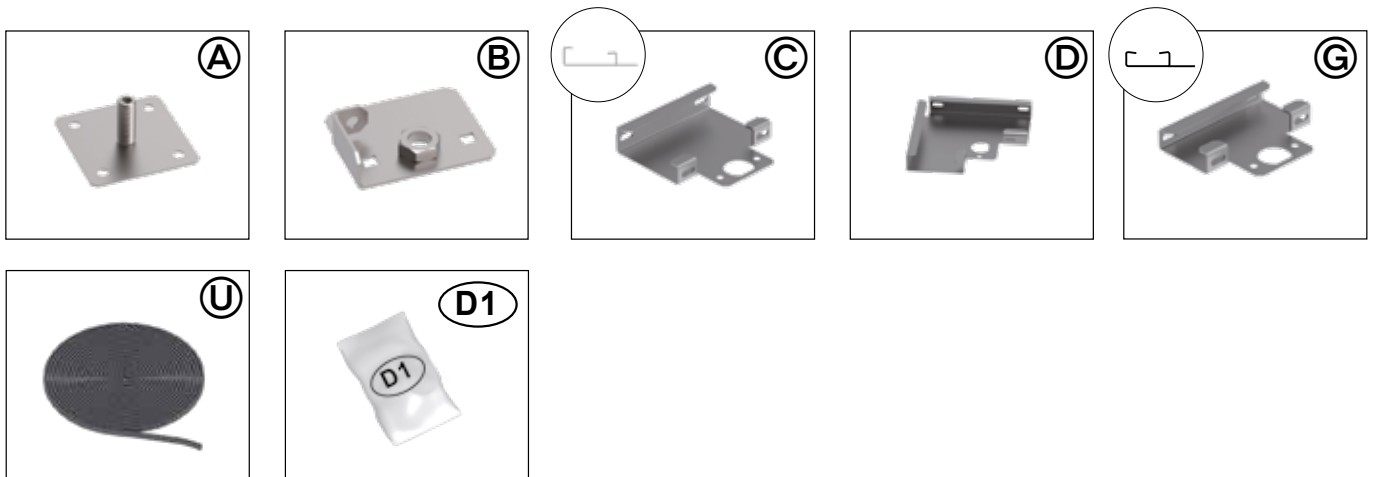

2 PROFIL - PAKET

Profilpaket · Profile package · Carton de profils · Profelpaket · Pacco profili · Kit de perfiles · Profilpakke

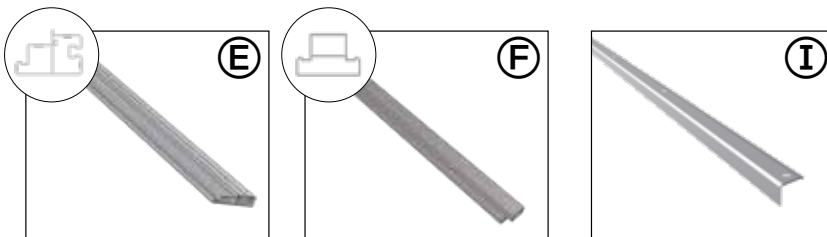

DIELLEN - PAKET

Dielenpaket · Floorboards package · Colis de lames · Plankenpakket · Pacco tavole per pavimento · Paquete de tablas de suelo · Gulvpakke

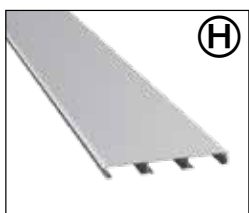

DIE AUF DEN PLÄNEN ROT MARKIERTEN STELFÜSSE SIND IMMER MITTIG IM (GEWÄHLTEN) TÜRBEREICH ZU SETZEN!



- (GB)** The adjustable feet marked in red on the plans must always be placed in the middle of the (selected) door area!
- (FR)** Les pieds réglables marqués en rouge sur les plans doivent toujours être placés au centre de la zone de la porte (choisie)!
- (NL)** De rood gemarkeerde stelvoeten op de plattegronden moeten altijd centraal in het (geselecteerde) deurbereik worden geplaatst!
- (ES)** Los pies niveladores marcados en rojo en los planos deben estar siempre en el centro de la zona de la puerta (seleccionada)!
- (IT)** I piedini di livellamento contrassegnati in rosso devono essere sempre posizionati centralmente nella zona della porta!
- (DK)** De justerbare fødder, der er markeret med rødt på planerne, skal altid placeres midt i det (valgte) dørråde!

ACHTUNG: WENN EINE ZUSATZTÜR VERBAUT WIRD, WIRD AUCH MITTIG UNTER DER ZUSATZTÜR EIN WEITERER STELFUSS BENÖTIGT!

- (GB)** ATTENTION: If an additional door is installed, an additional adjustable foot is also required in the middle under the additional door!
- (FR)** ATTENTION : Si une porte supplémentaire est installée, un pied réglable supplémentaire est également nécessaire au centre sous la porte supplémentaire !
- (NL)** LET OP: Als er een extra deur wordt geïnstalleerd, is er ook een extra verstelbare voet nodig in het midden onder de extra deur!
- (ES)** ATENCIÓN: Si se instala una puerta adicional, se requiere un pie ajustable adicional en el centro debajo de la puerta adicional!
- (IT)** ATTENZIONE: Se viene installata una porta aggiuntiva, è necessario anche un piedino regolabile aggiuntivo al centro sotto la porta aggiuntiva!
- (DK)** OBS: Hvis der er installeret en ekstra dør, kræves der også en ekstra justerbar fod i midten under den ekstra dør!



Fundamentplan

FOUNDATION PLAN | PLAN DE FONDATION | FUNDERINGSPLAN |
PLANO DE LOS CIMIENTOS | PIANO DI FONDAZIONE | FUNDAMENT PLAN

Geräteschrank

Equipment locker
Armoire à outils

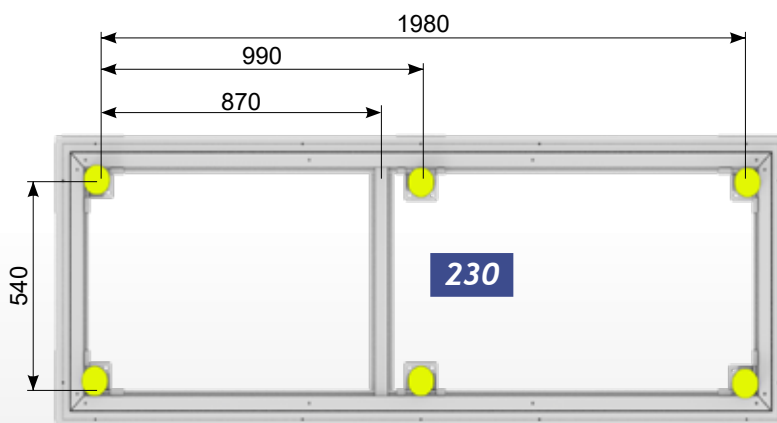
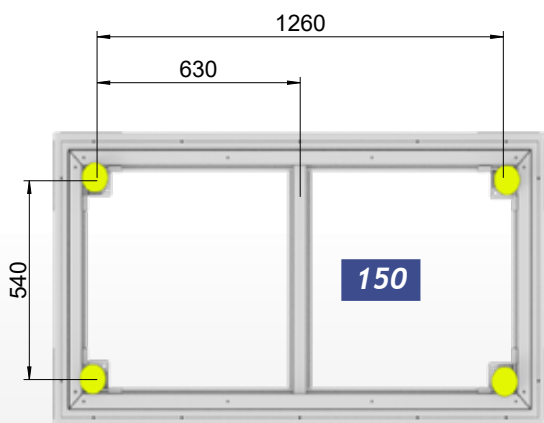
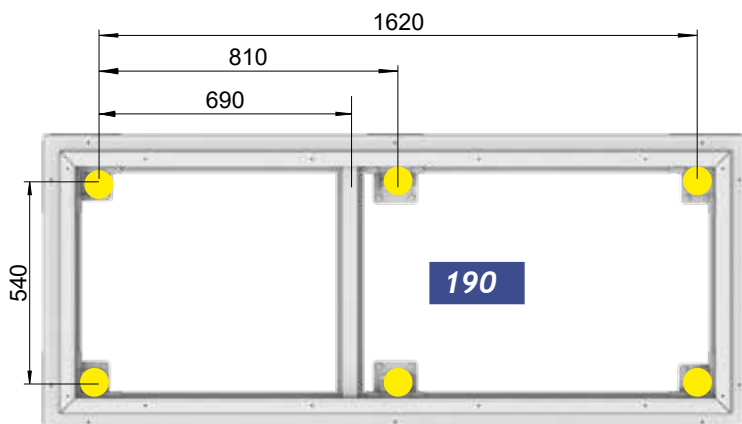
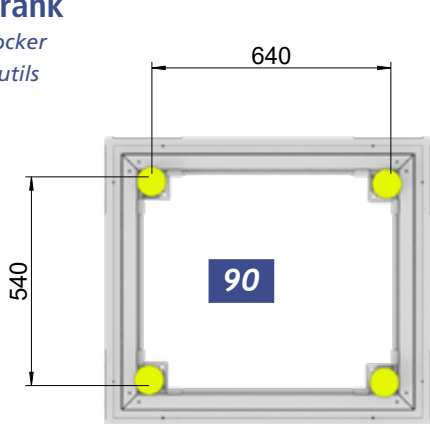



Europa

1

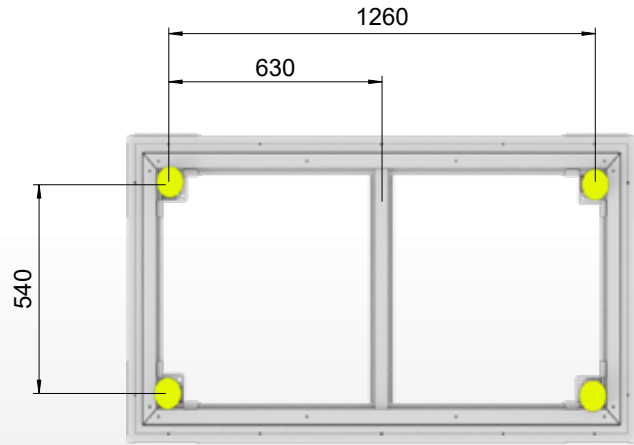

2

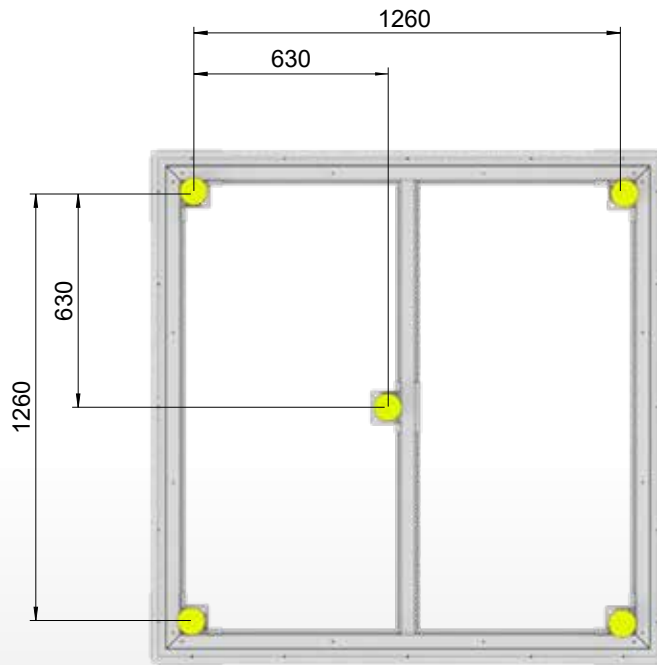

2A

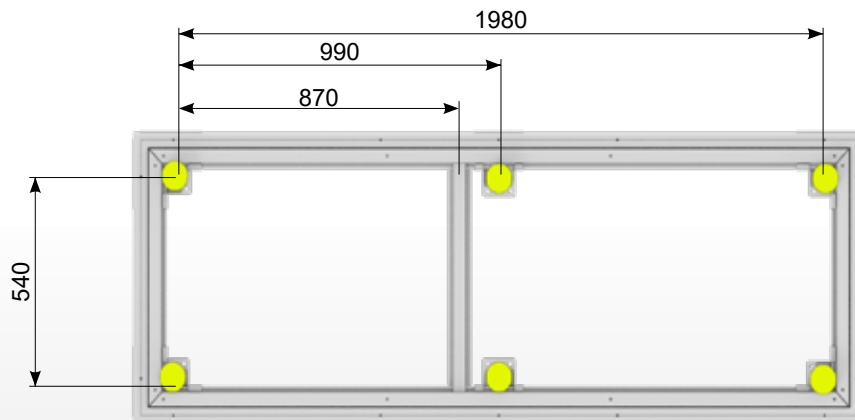

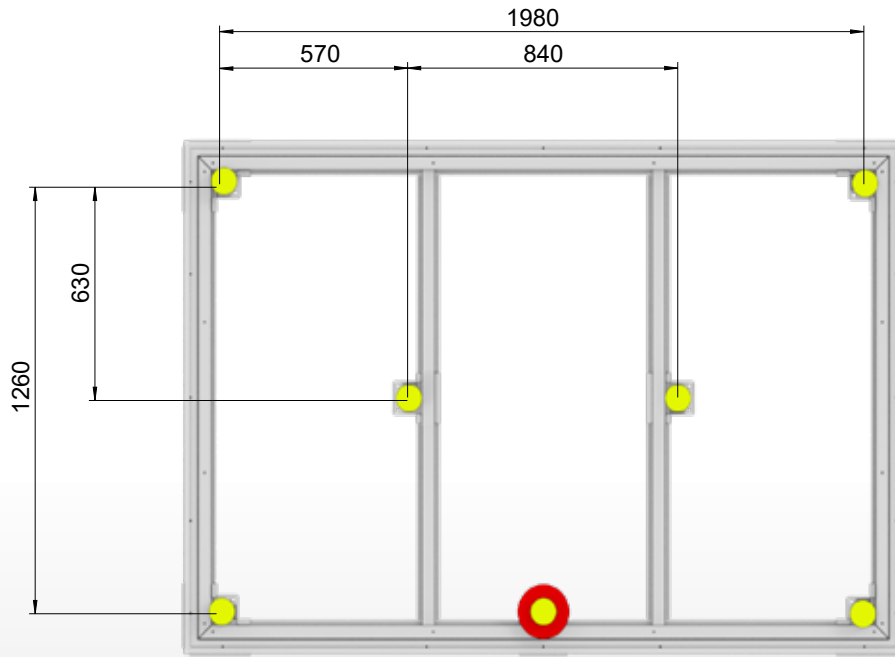

3

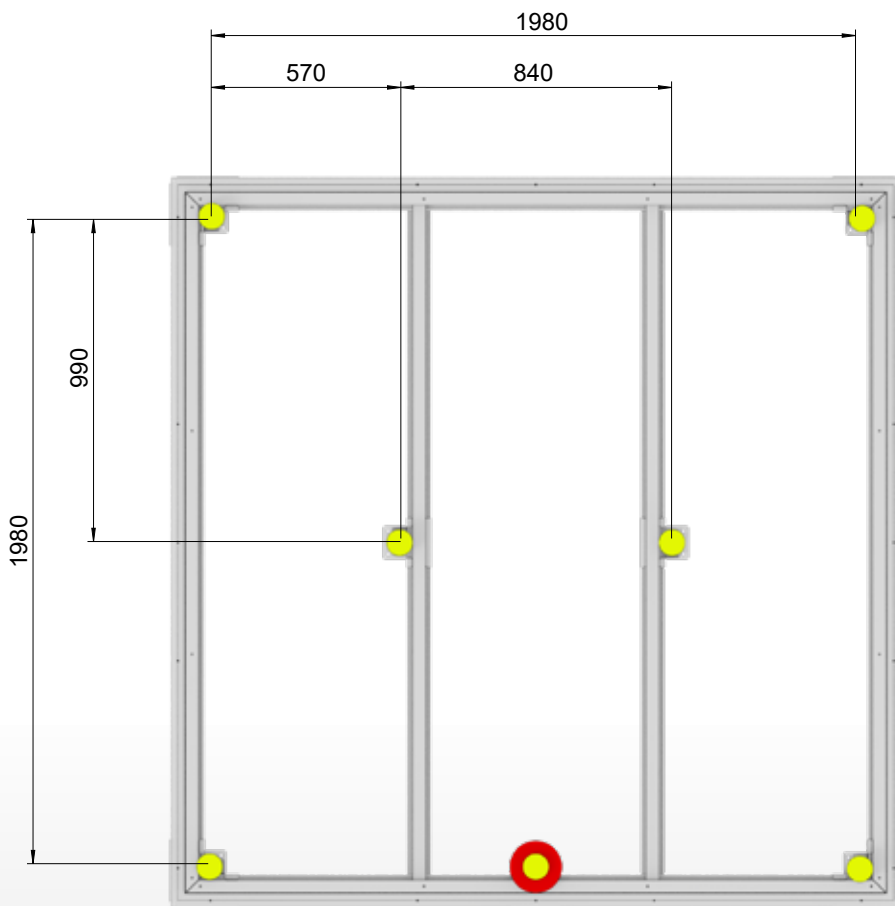

4

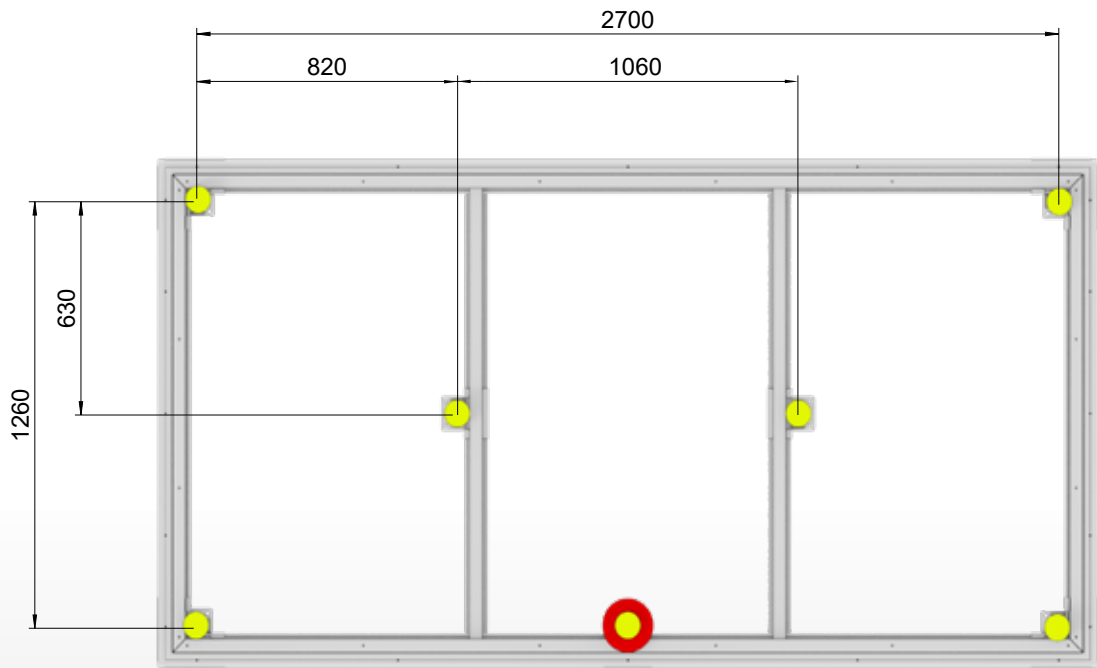

4A

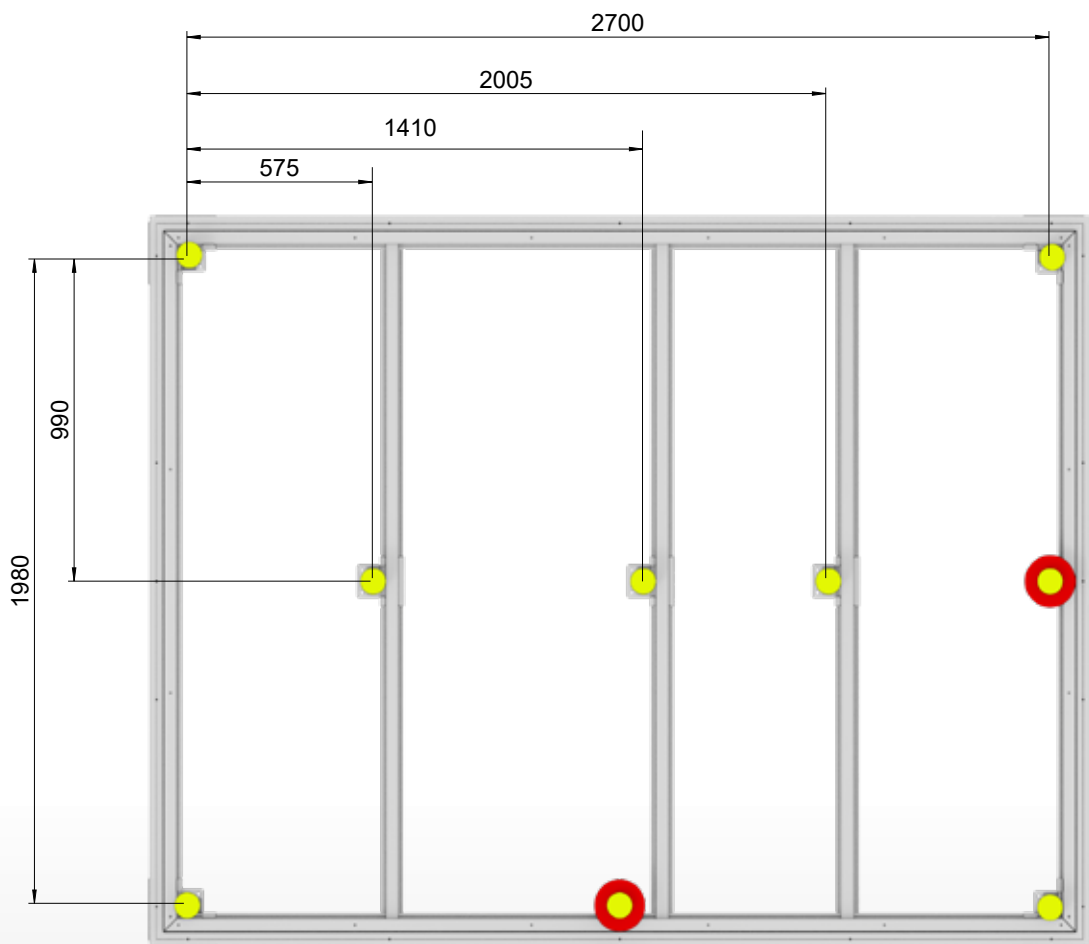

6

5, 6

5

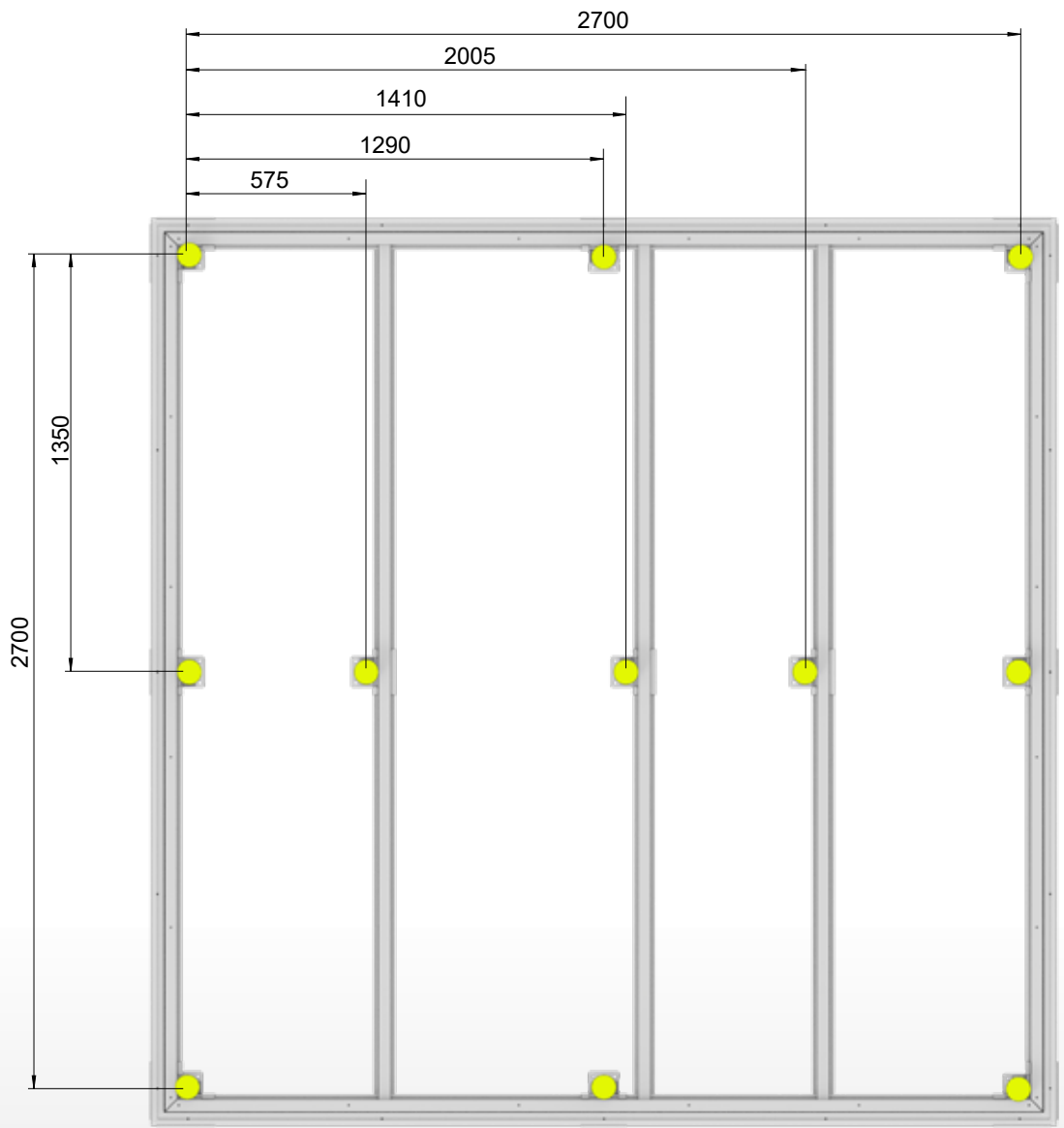

7



AvantGarde®

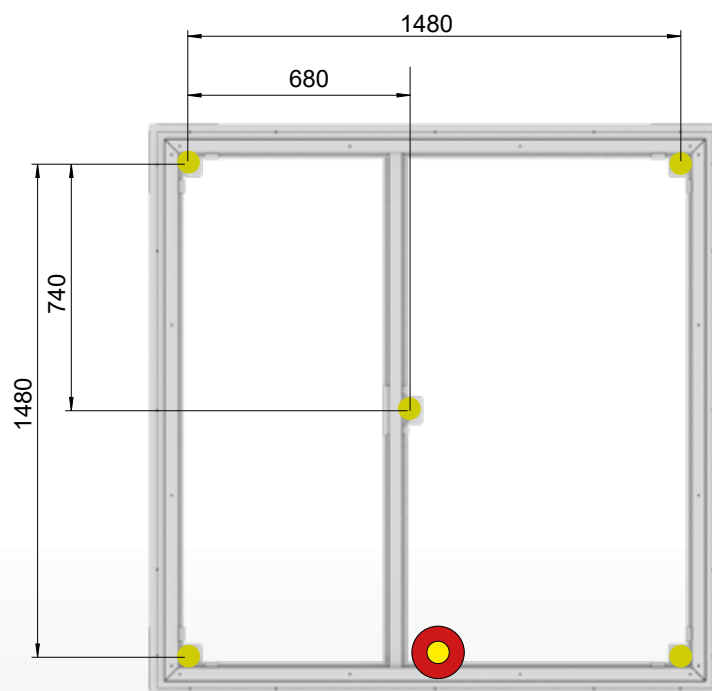

A1

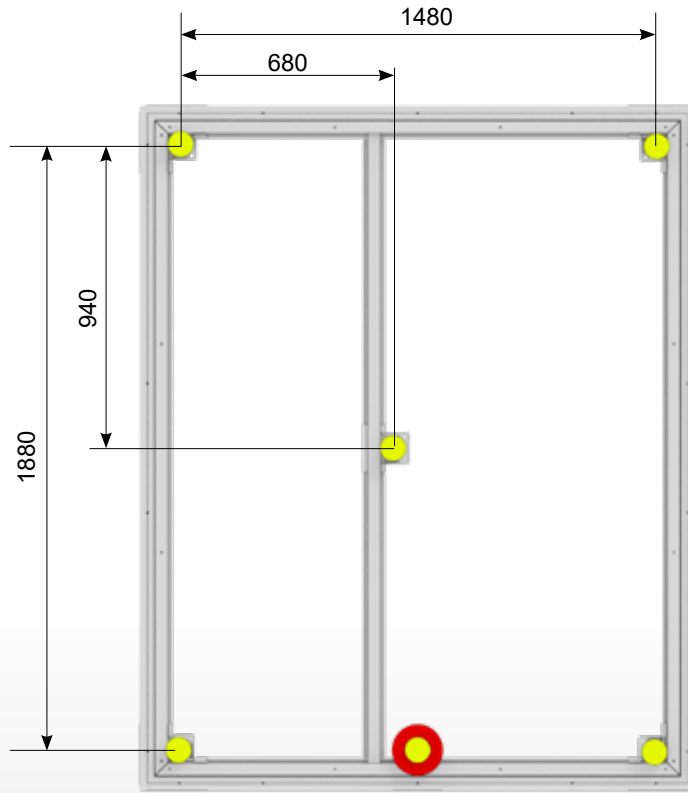

A2

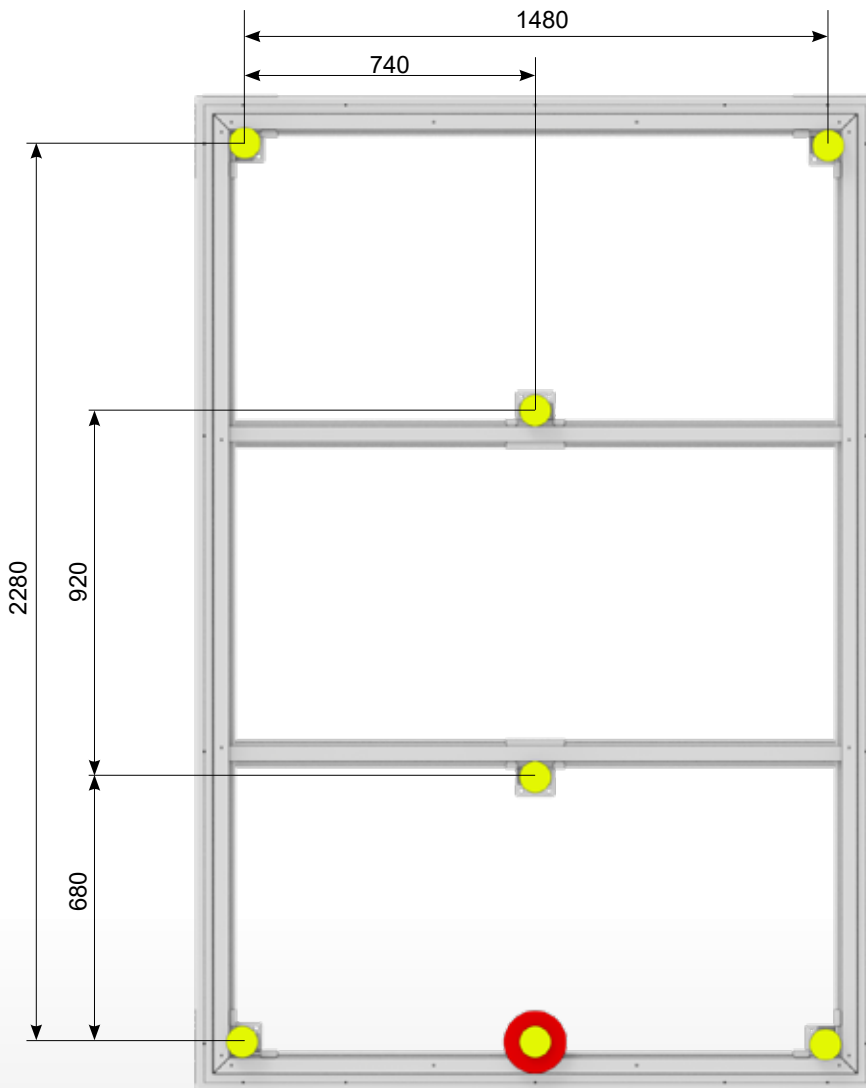

A3

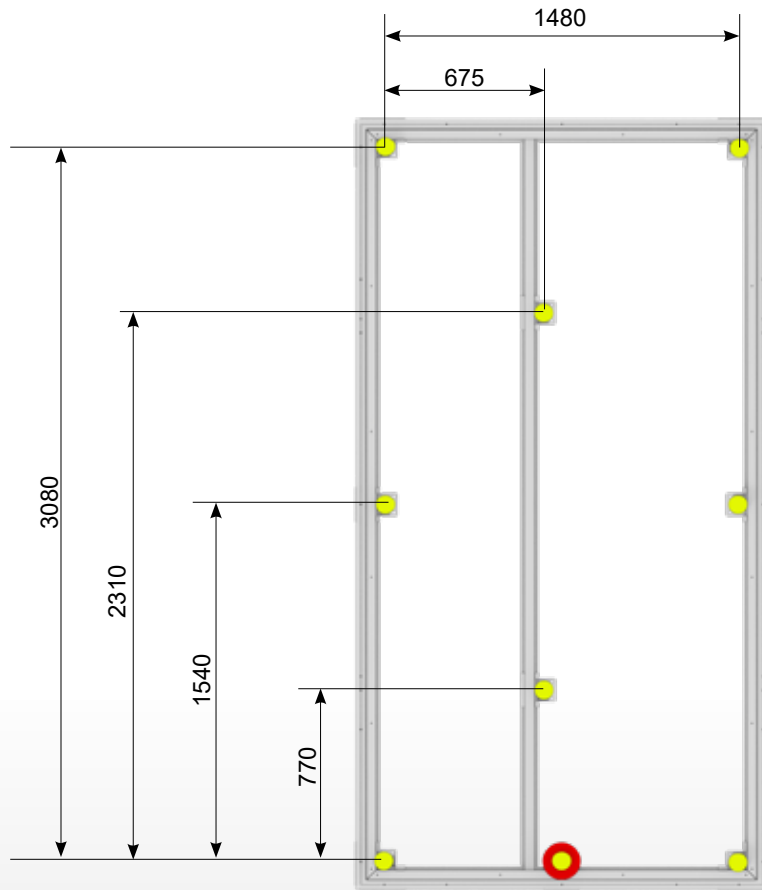

A4

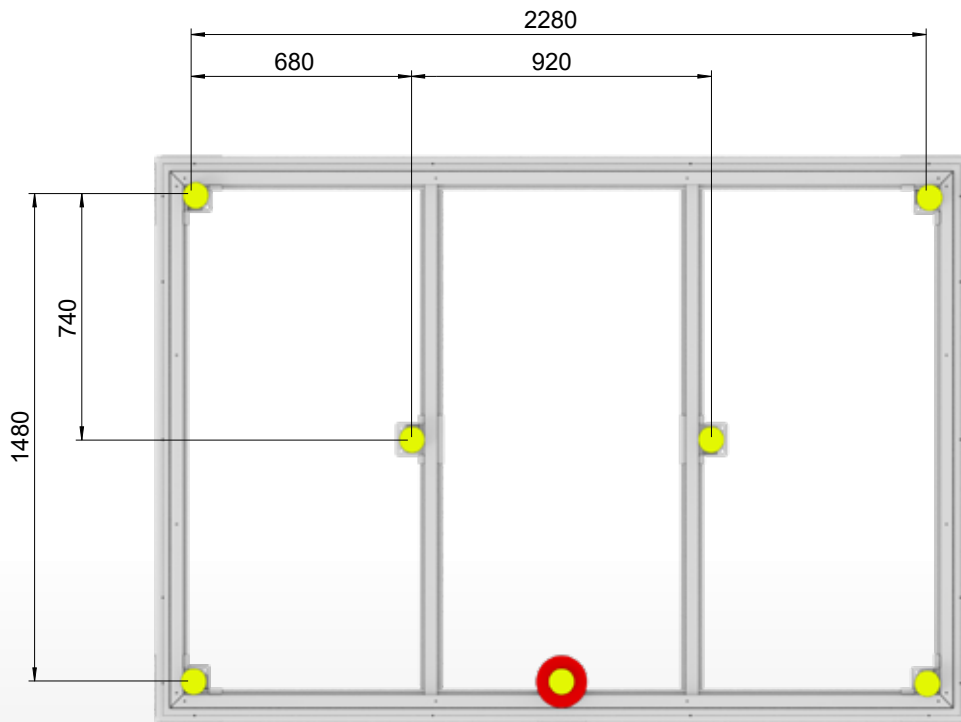

A5

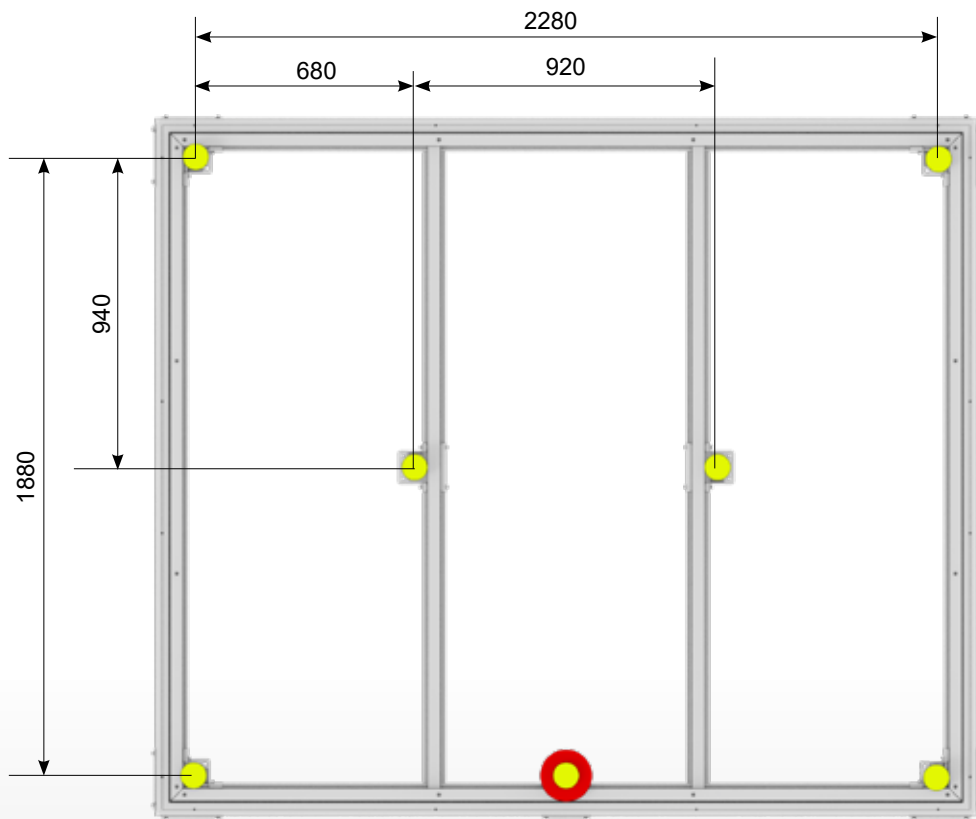

A6

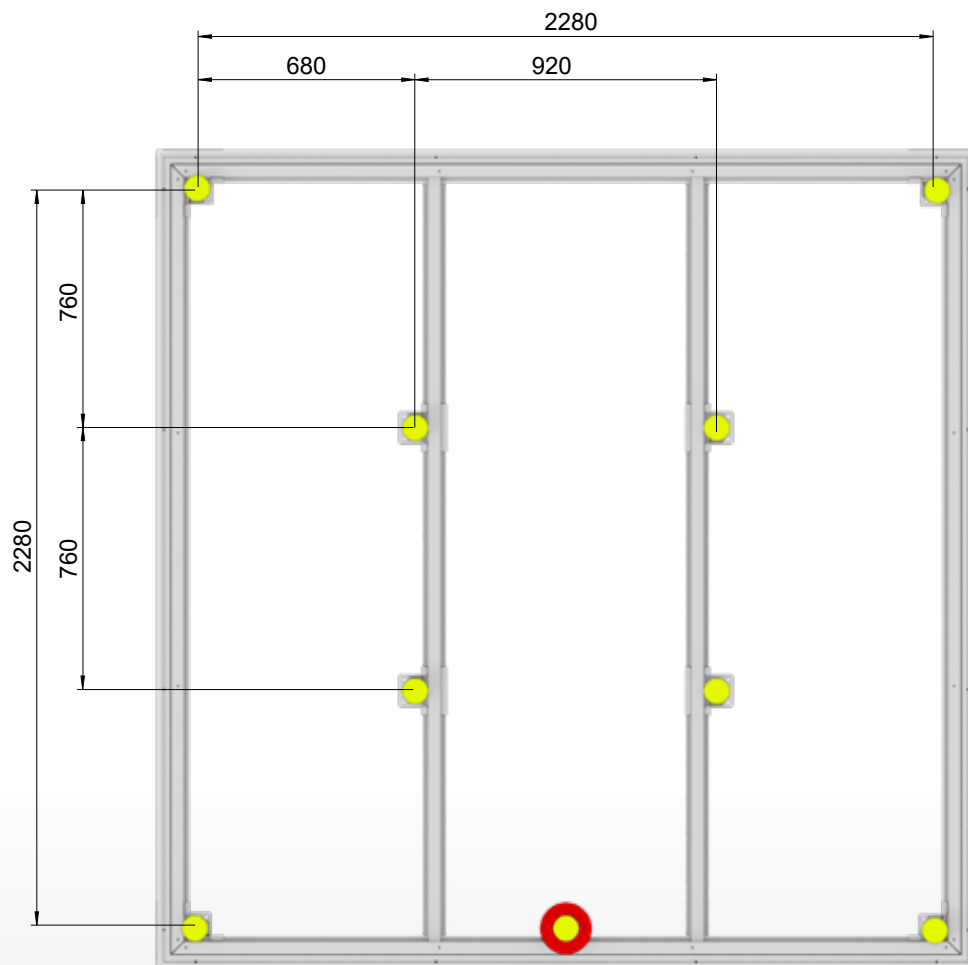

A7

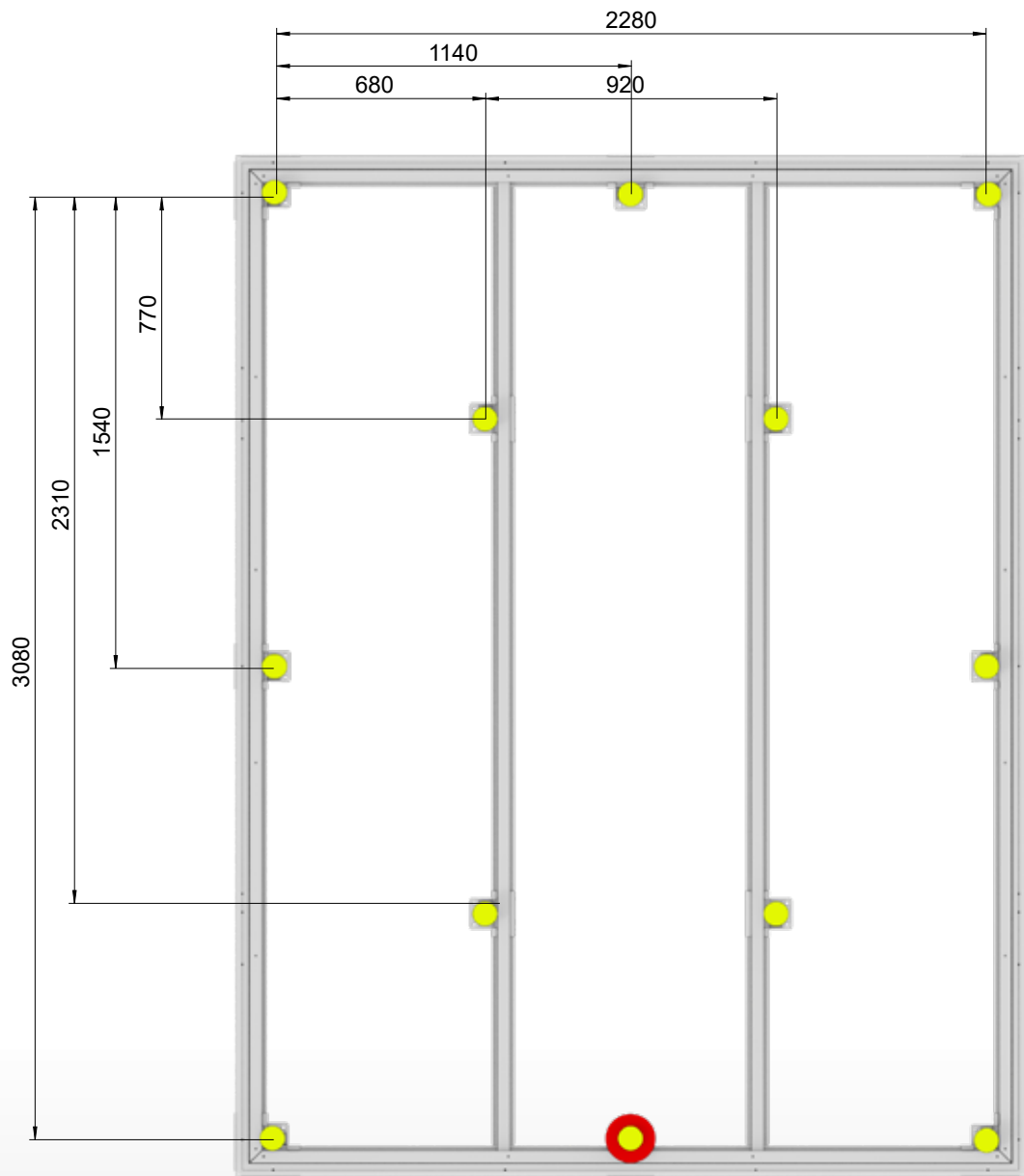

A8



HighLine®



Panorama®

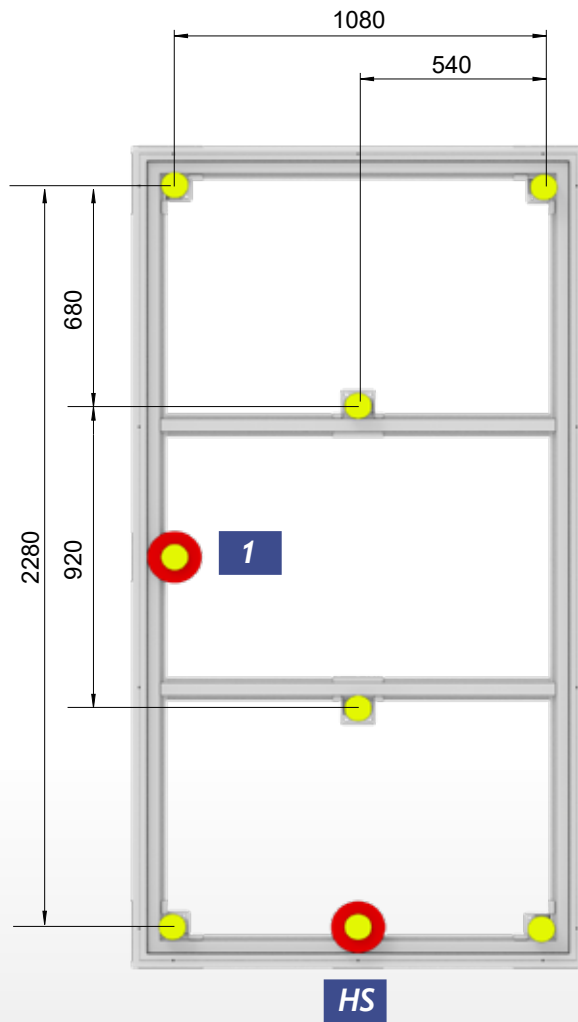

HS 1

HS

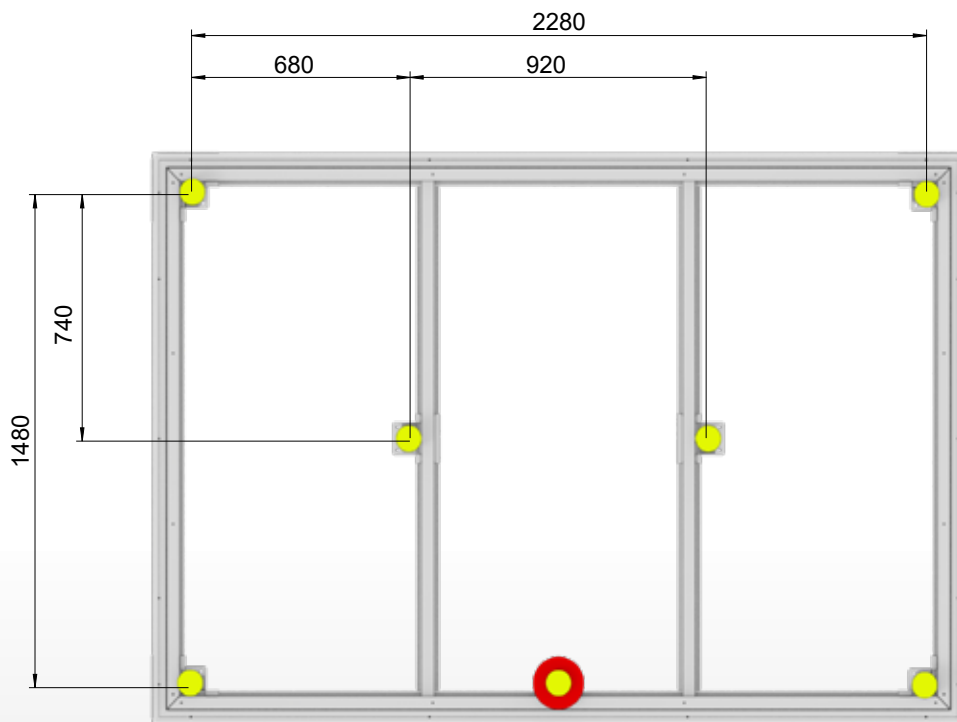

2

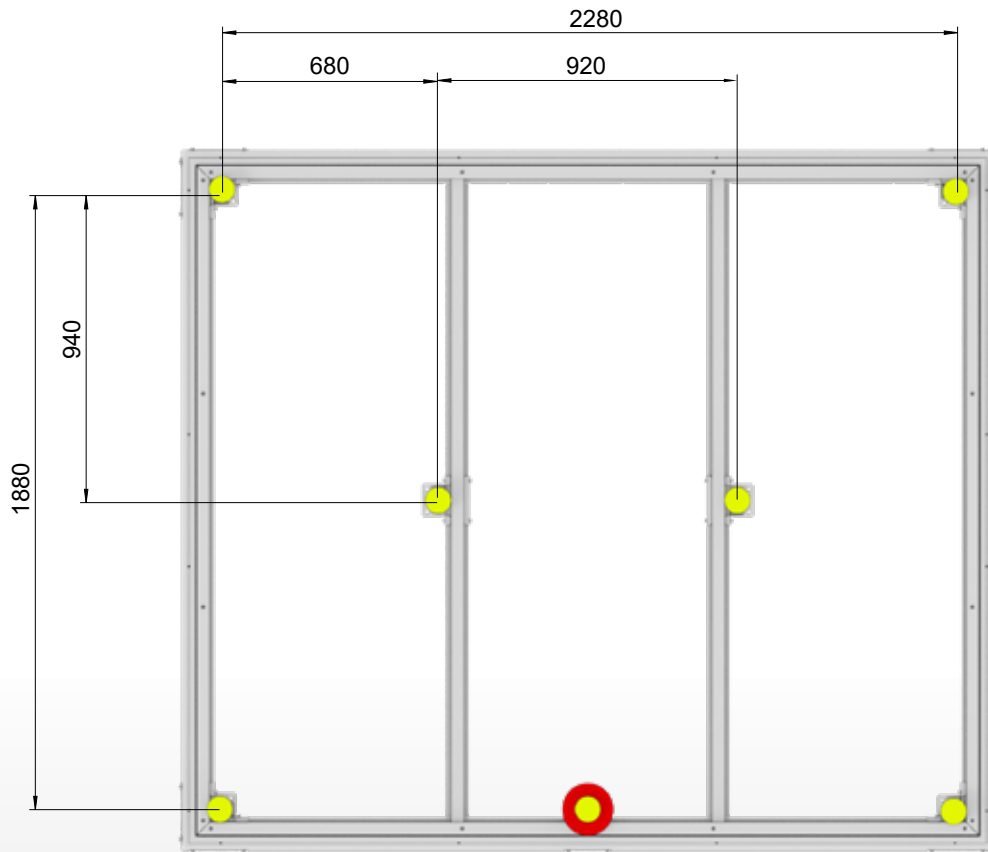

3

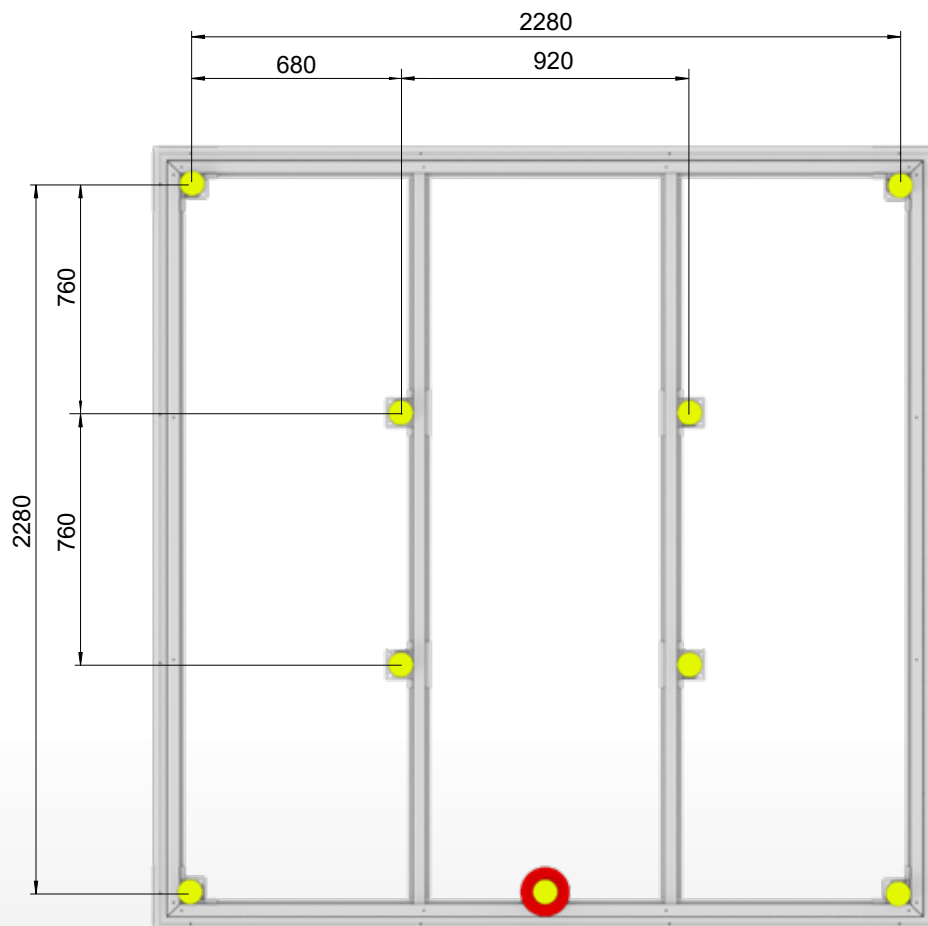

4

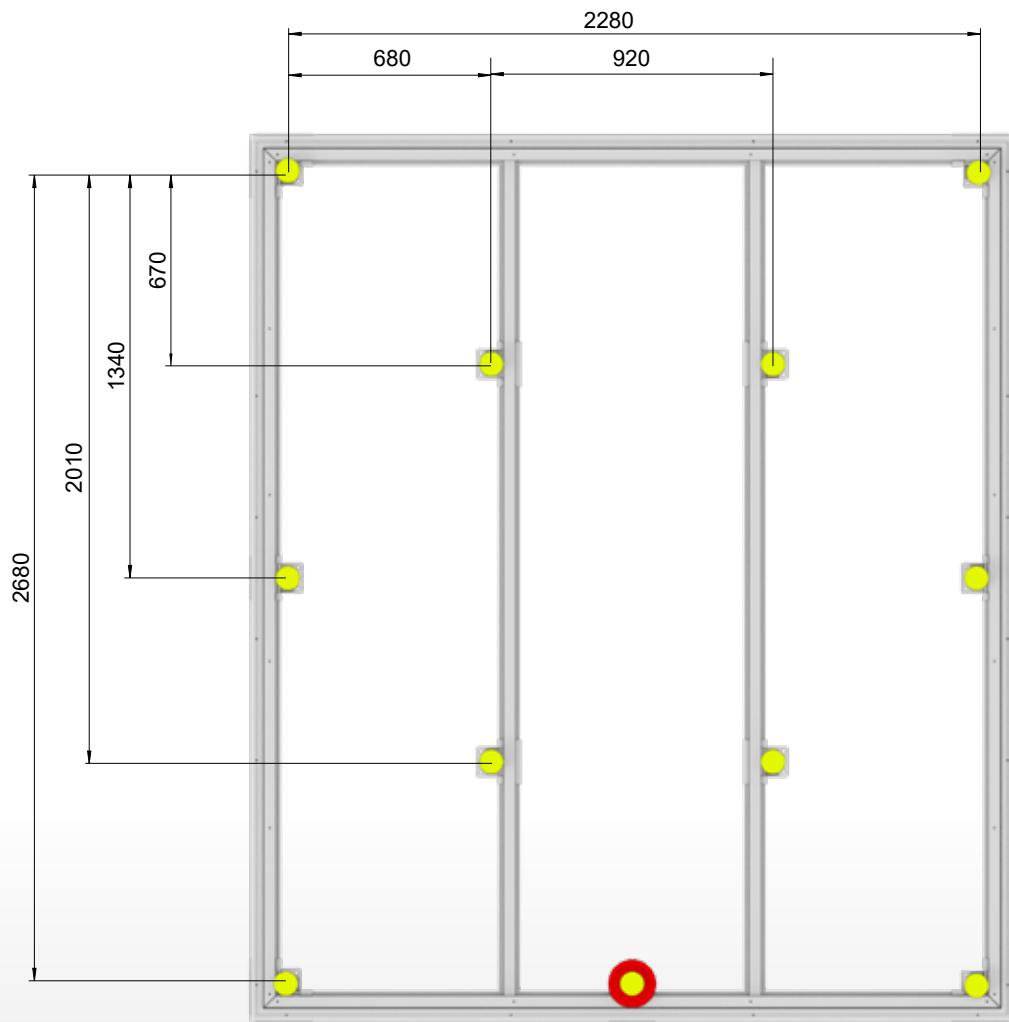

5

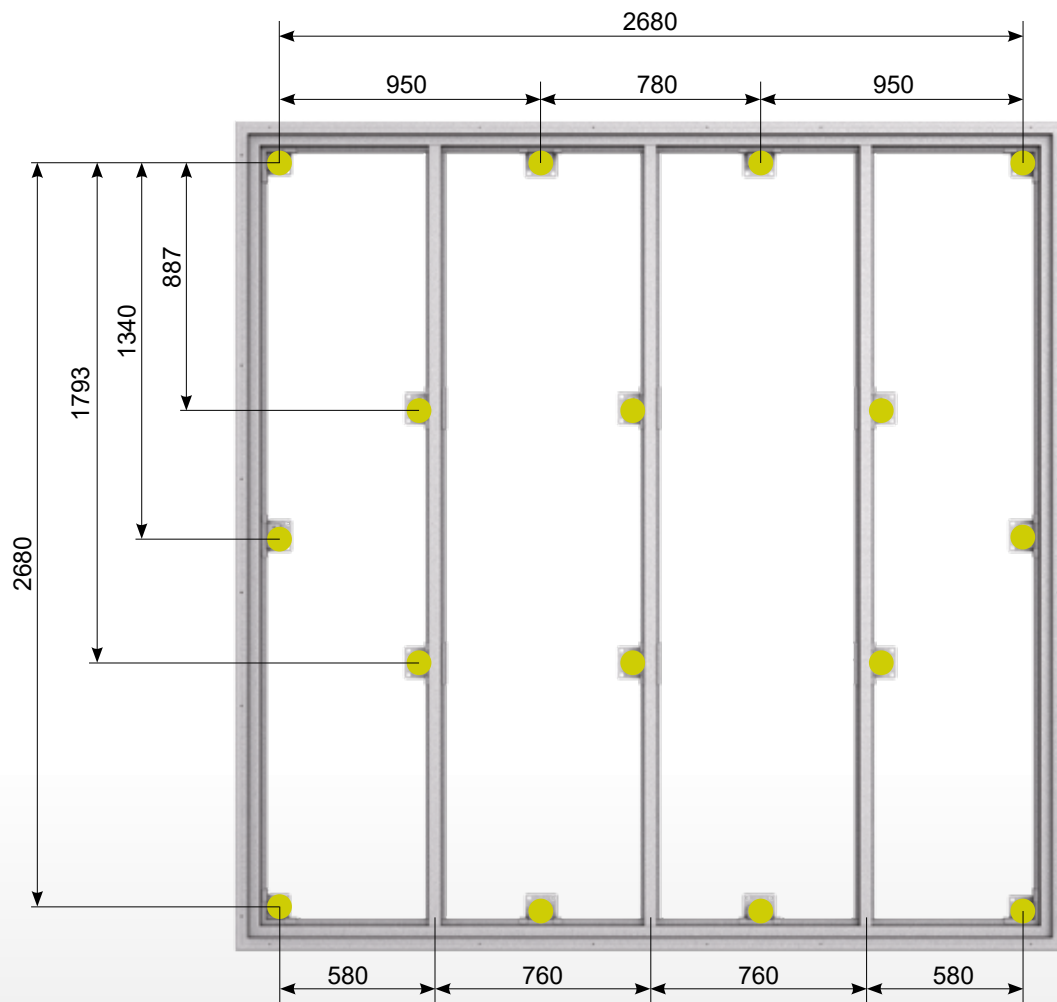

6



MiniGarage

M

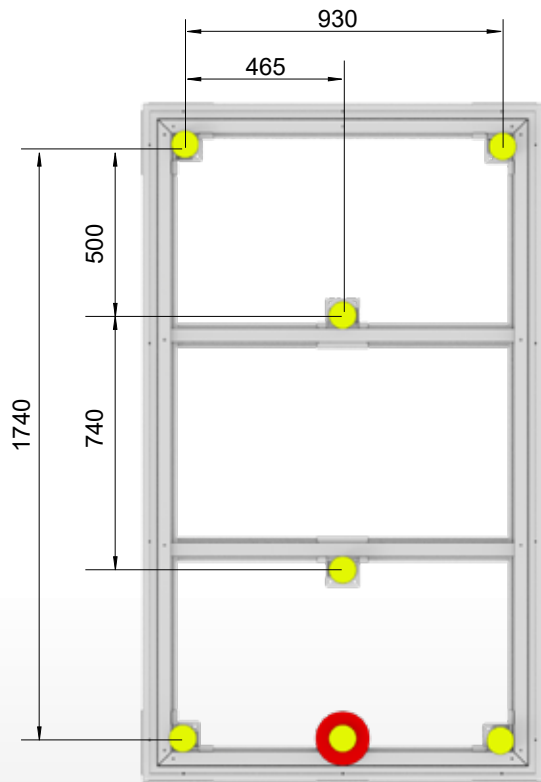

L

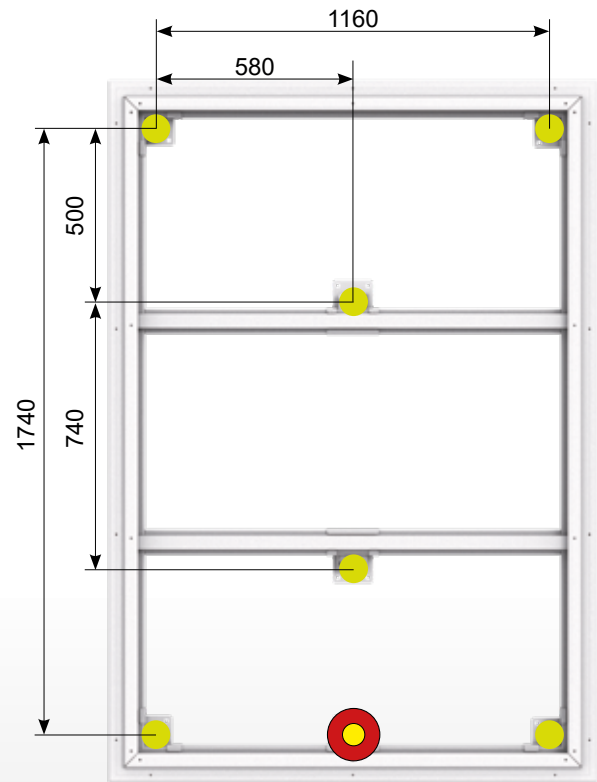



NEO

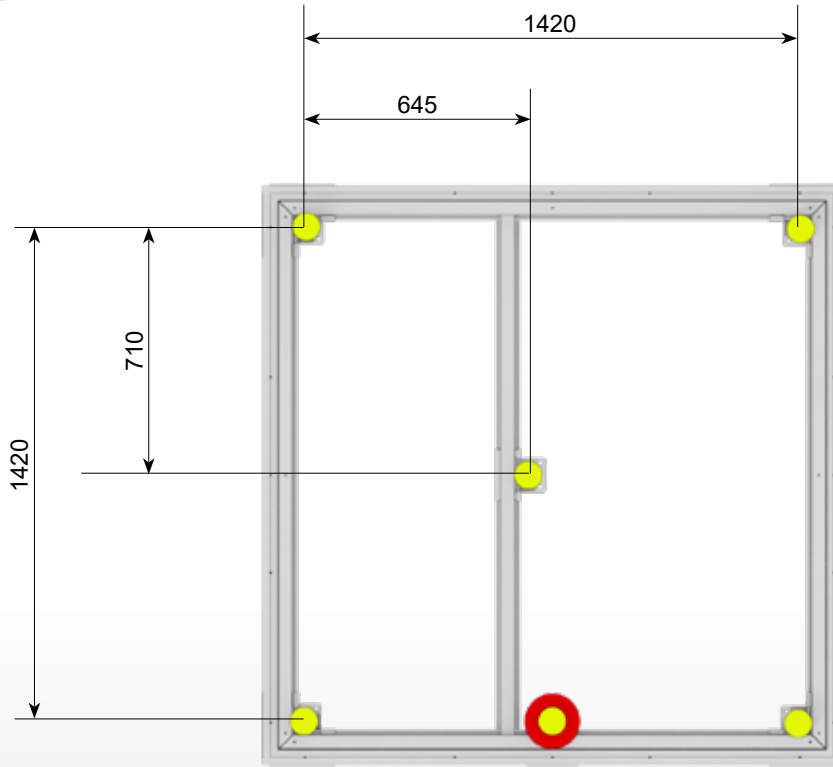

1A

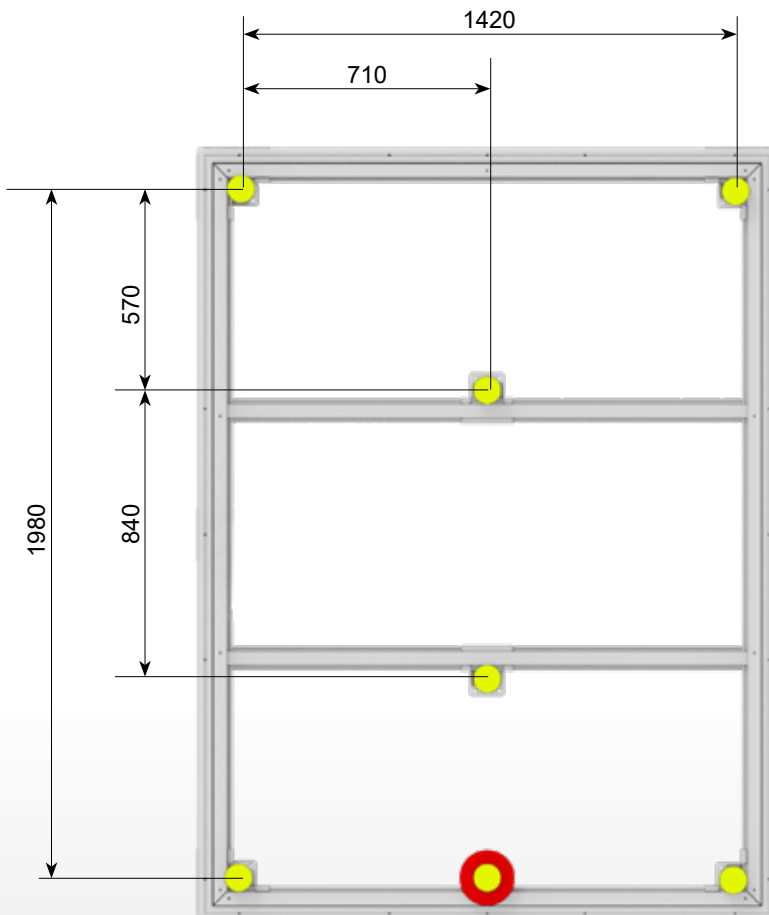

2A

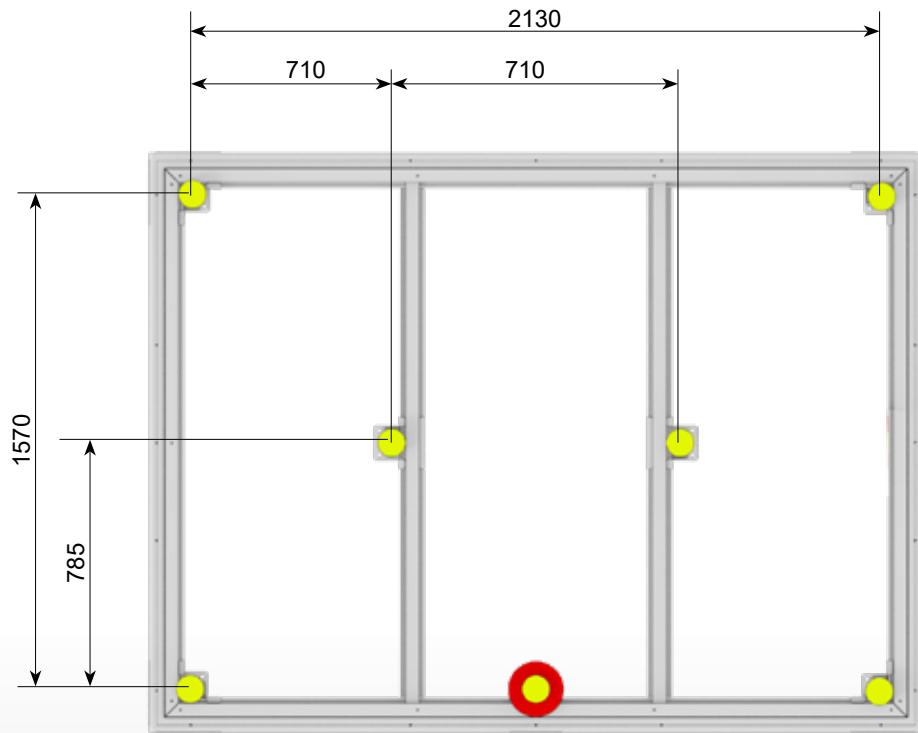



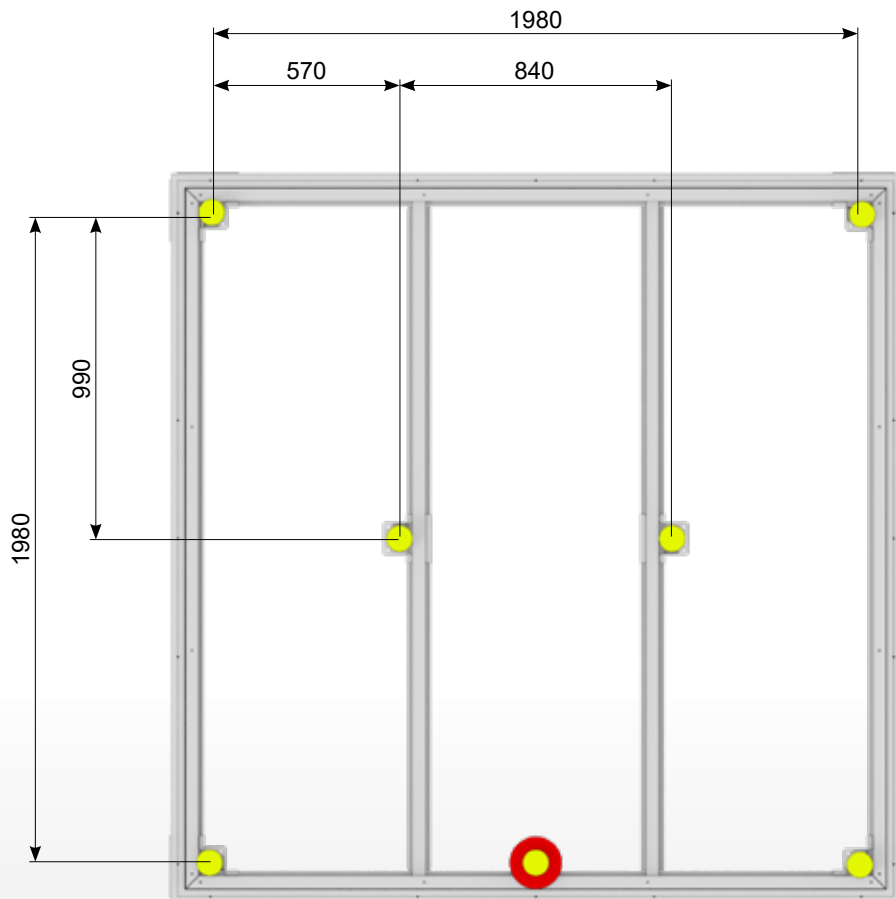

1B



2B

1.

 <p>E</p>	<p>Europa</p> <p>1: 2X (780mm) 2: 4X (1500mm) 2A: 2X (780mm) 3: 2X (1500mm)</p>	<p>Europa</p> <p>4: 4X (2220mm) 4A: 2X (1500mm) 5: 2X (2220mm) 6: 2X (2220mm) 7: 4X (2940mm)</p>	<p>HighLine® Panorama®</p> <p>HS: 2X (1320mm) 1: 2X (1320mm) 2: 2X (1720mm) 3: 2X (2120mm) 4: 4X (2520mm) 5: 2X (2520mm) 6: 4X (2920mm)</p>	<p>AvantGarde®</p> <p>A1: 4X (1720mm) A2: 2X (1720mm) A3: 2X (1720mm) A4: 2X (1720mm) A5: 2X (2520mm) A6: 2X (2520mm) A7: 4X (2520mm) A8: 2X (2520mm)</p>	<p>Geräteschrank Equipment Locker Armoire à outils</p> <p>90: 2X (780mm) 150: 2X (780mm) 190: 2X (780mm) 230: 2X (780mm)</p>	<p>MiniGarage</p> <p>M: 2X (1980mm) L: 2X (1980mm)</p> <hr/> <p>NEO</p> <p>1A: 4X (1660mm) 2A: 2X (2220mm) 1B: 2X (2220mm) 2B: 4X (2220mm)</p>
 <p>E</p>	<p>Europa</p> <p>1: 2X (1500mm) 2: 0X 2A: 2X (2220mm) 3: 2X (2220mm)</p>	<p>Europa</p> <p>4: 0X 4A: 2X (2940mm) 5: 2X (2940mm) 6: 2X (2940mm) 7: 0X</p>	<p>HighLine® Panorama®</p> <p>HS: 2X (2520mm) 1: 2X (2520mm) 2: 2X (2520mm) 3: 2X (2520mm) 4: 0X 5: 2X (2920mm) 6: 0X</p>	<p>AvantGarde®</p> <p>A1: 0X A2: 2X (2120mm) A3: 2X (2520mm) A4: 2X (3220mm) A5: 2X (1720mm) A6: 2X (2120mm) A7: 0X A8: 2X (3220mm)</p>	<p>Geräteschrank Equipment Locker Armoire à outils</p> <p>90: 2X (880mm) 150: 2X (1500mm) 190: 2X (1860mm) 230: 2X (2220mm)</p>	<p>MiniGarage</p> <p>M: 2X (1170mm) L: 2X (1400mm)</p> <hr/> <p>NEO</p> <p>1A: 0X 2A: 2X (1660mm) 1B: 2X (1660mm) 2B: 0X</p>
 <p>C</p>	<p>Europa</p> <p>1: 0X 2: 0X 2A: 2X 3: 1X</p>	<p>Europa</p> <p>4: 1X 4A: 1X 5: 1X 6: 1X 7: 4X</p>	<p>HighLine® Panorama®</p> <p>HS: 1X 1: 1X 2: 1X 3: 1X 4: 1X 5: 3X 6: 6X</p>	<p>AvantGarde®</p> <p>A1: 1X A2: 1X A3: 1X A4: 3X A5: 1X A6: 1X A7: 1X A8: 4X</p>	<p>Geräteschrank Equipment Locker Armoire à outils</p> <p>90: 0X 150: 0X 190: 2X 230: 2X</p>	<p>MiniGarage</p> <p>M: 1X L: 1X</p> <hr/> <p>NEO</p> <p>1A: 1X 2A: 1X 1B: 1X 2B: 1X</p>
<p>4,8 x 60</p>  <p>D1</p>	<p>4x</p>	 <p>4x</p> <p>D</p>				

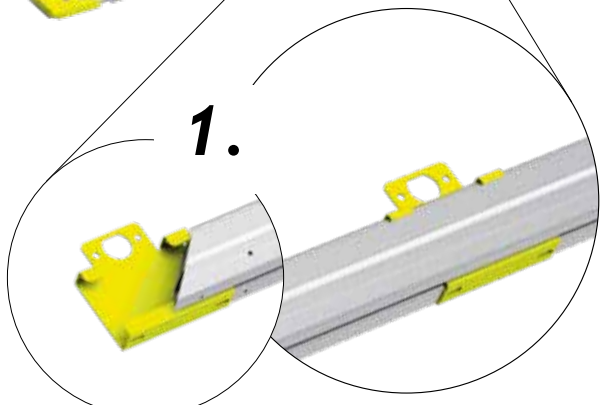
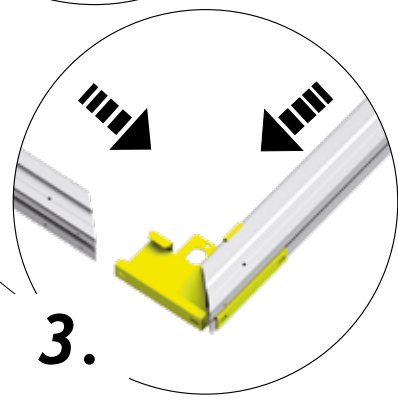
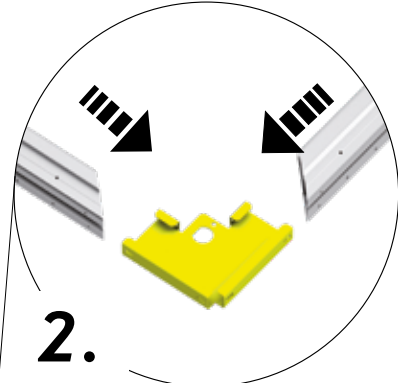
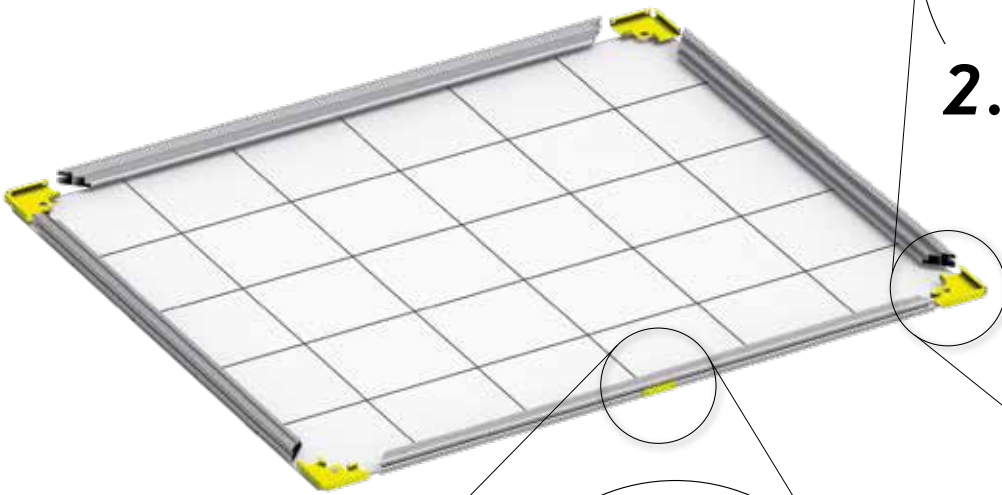

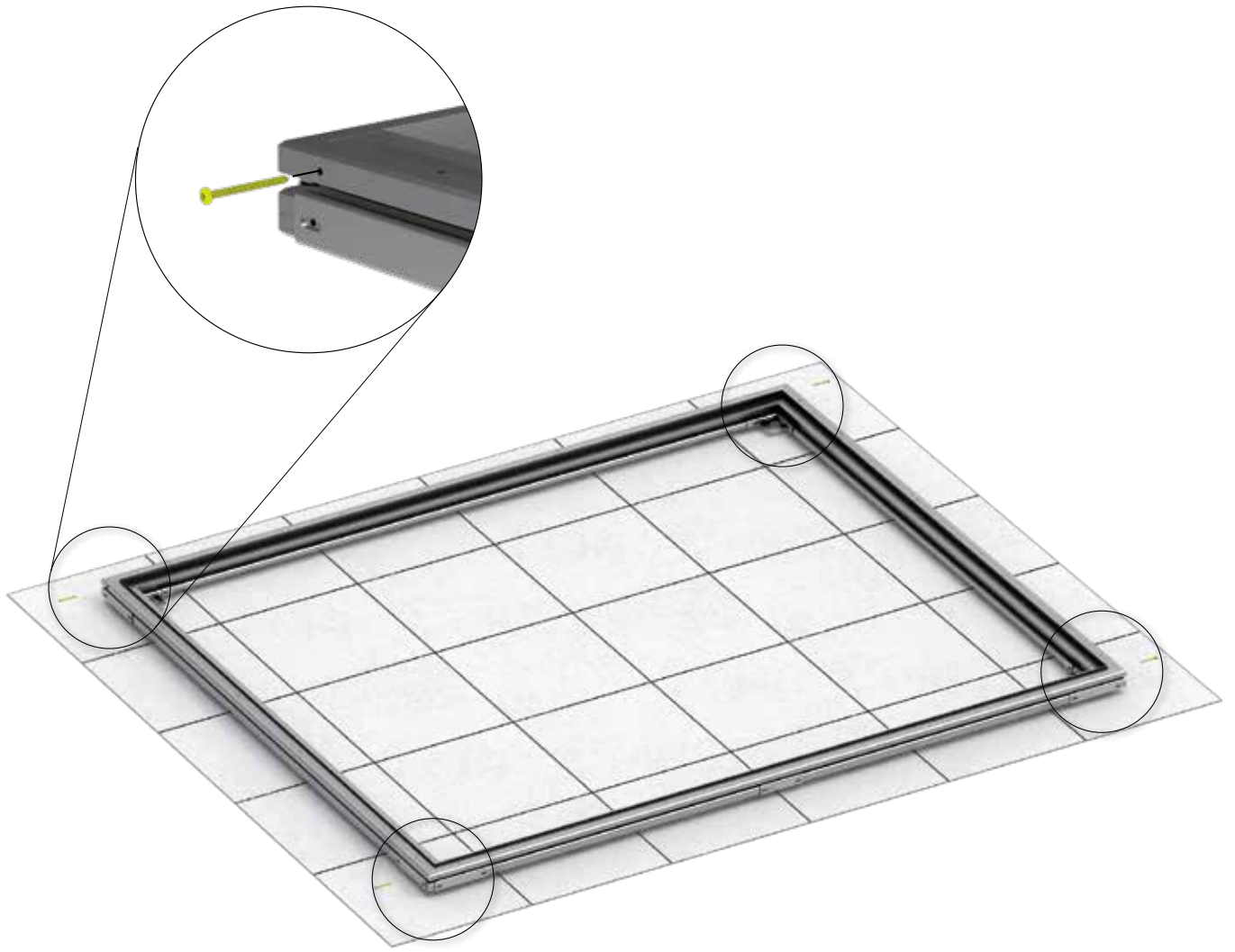

2.



Europa

1: 1X (614mm)
 2: 1X (1334mm)
 2A: 1X (614mm)
 3: 2X (1334mm)

Europa

4: 2X (2054mm)
 4A: 2X (1334mm)
 5: 3X (2054mm)
 6: 3X (2054mm)
 7: 3X (2774mm)

**HighLine®
Panorama®**

HS: 2X (1154mm)
 1: 2X (1154mm)
 2: 2X (1554mm)
 3: 2X (1954mm)
 4: 2X (2354mm)
 5: 2X (2754mm)
 6: 3X (2754mm)

AvantGarde®

A1: 1X (1554mm)
 A2: 1X (1954mm)
 A3: 2X (1554mm)
 A4: 1X (3154mm)
 A5: 2X (1554mm)
 A6: 2X (1954mm)
 A7: 2X (2354mm)
 A8: 2X (3154mm)

Geräteschrank
Equipment Locker
Armoire à outils

90: 0X
 150: 1X (614mm)
 190: 1X (614mm)
 230: 1X (614mm)

MiniGarage

M: 2X (1004mm)
 L: 2X (1234mm)

NEO

1A: 1X (1494mm)
 2A: 2X (1494mm)
 1B: 2X (1494mm)
 2B: 2X (2054mm)



Europa

1: 0X
 2: 1X
 2A: 0X
 3: 2X

Europa

4: 2X
 4A: 2X
 5: 3X
 6: 3X
 7: 3X

**HighLine®
Panorama®**

HS: 2X
 1: 2X
 2: 2X
 3: 2X
 4: 4X
 5: 4X
 6: 6X

AvantGarde®

A1: 1X
 A2: 1X
 A3: 2X
 A4: 2X
 A5: 2X
 A6: 2X
 A7: 4X
 A8: 4X

Geräteschrank
Equipment Locker
Armoire à outils

90: 0X
 150: 0X
 190: 0X
 230: 0X

MiniGarage

M: 2X
 L: 2X

NEO

1A: 1X
 2A: 2X
 1B: 2X
 2B: 2X

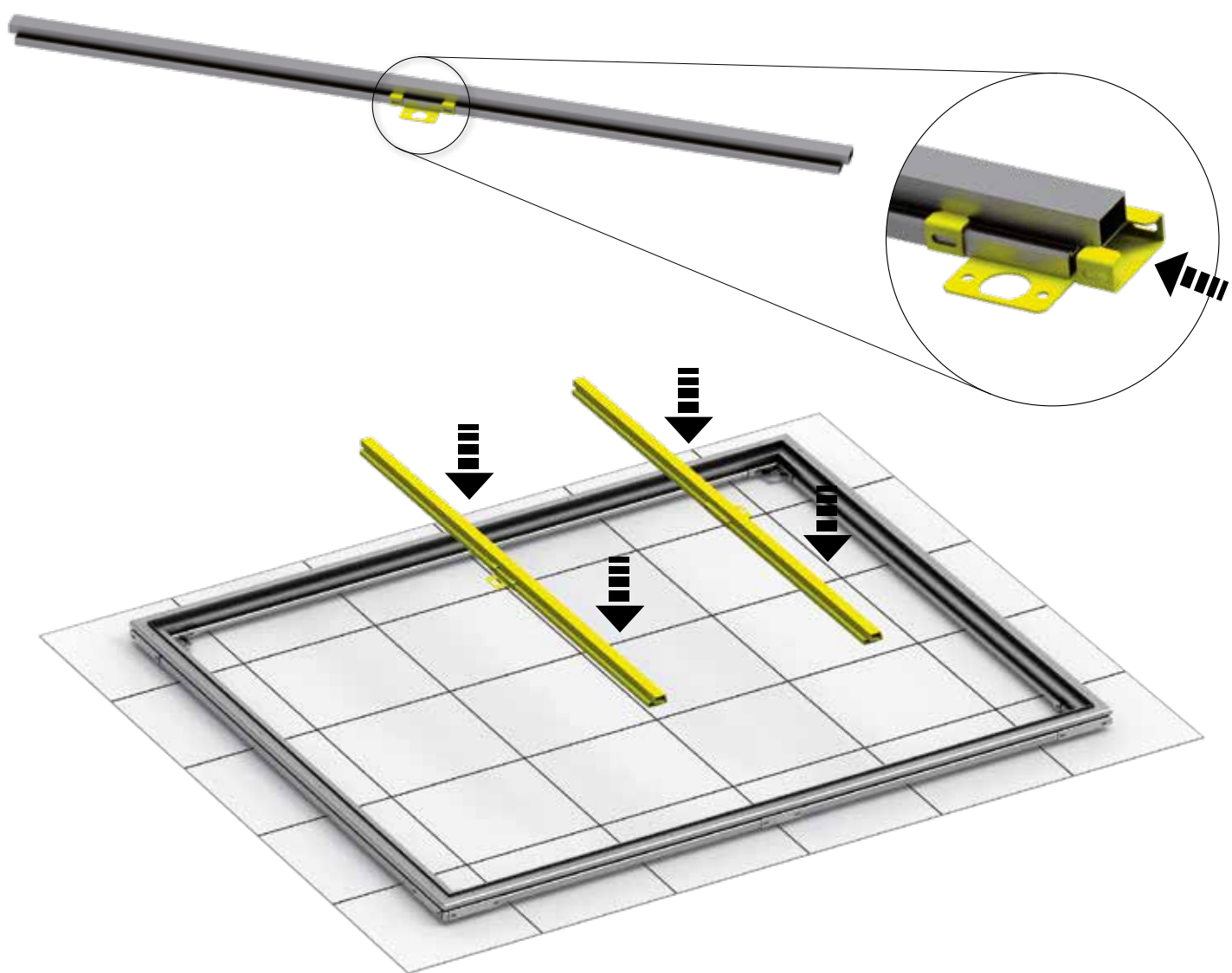

3.

6,3 x 22 *



D1

Europa

- 1: 24x
- 2: 28x
- 2A: 32x
- 3: 36x

Europa

- 4: 36x
- 4A: 36x
- 5: 40x
- 6: 40x
- 7: 52x

HighLine® Panorama®

- HS: 36x
- 1: 36x
- 2: 36x
- 3: 36x
- 4: 44x
- 5: 52x
- 6: 80x

AvantGarde®

- A1: 32x
- A2: 32x
- A3: 36x
- A4: 44x
- A5: 36x
- A6: 36x
- A7: 44x
- A8: 56x

Geräteschrank

Equipment Locker

Armoire à outils

- 90: 24x
- 150: 24x
- 190: 32x
- 230: 32x

MiniGarage

- M: 36x
- L: 36x

NEO

- 1A: 32x
- 2A: 36x
- 1B: 36x
- 2B: 36x

*Selbstschneidende Schraube
Self-tapping screw - Vis autotaraudeuse

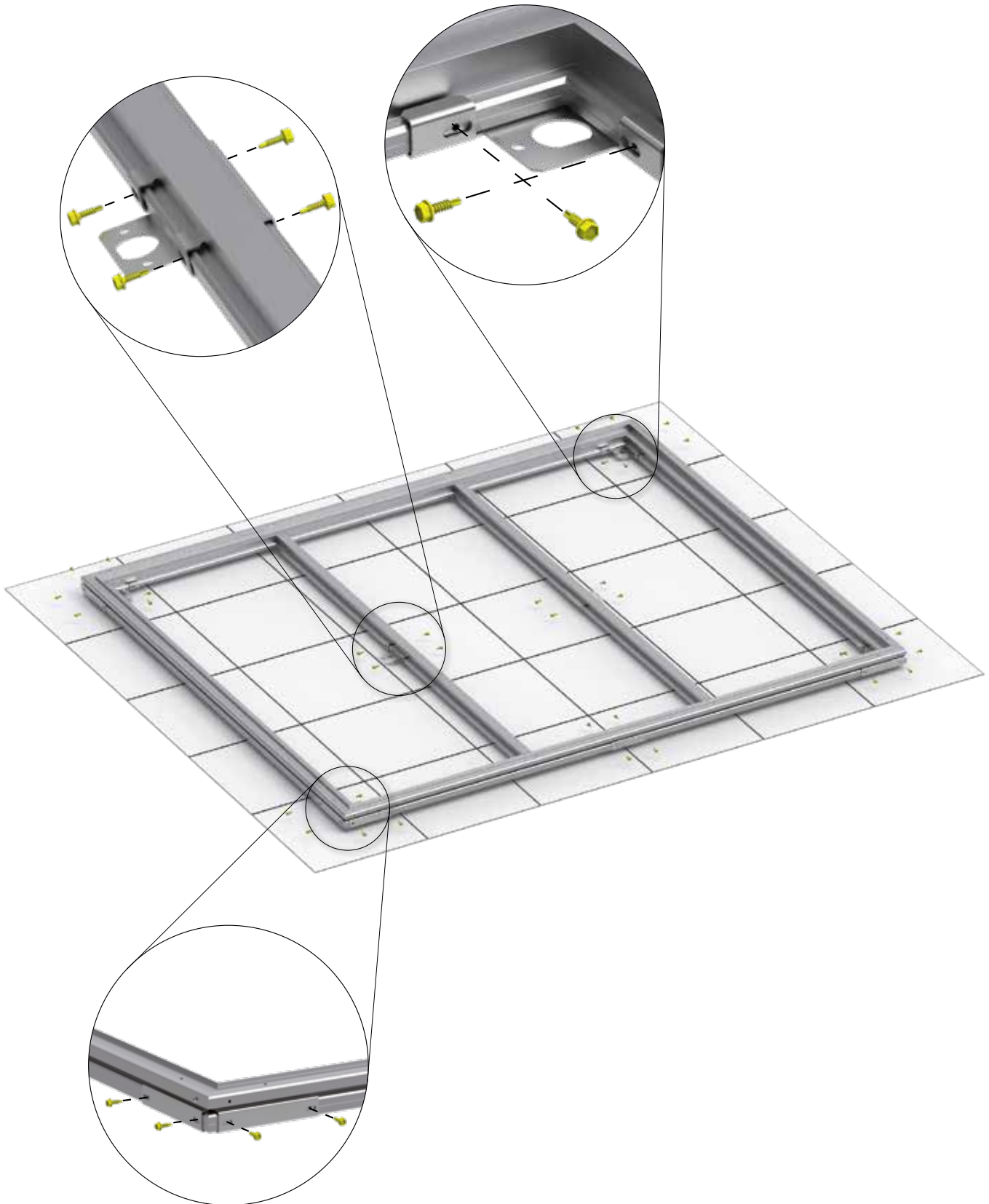

4.



ⓑ

Europa

- 1: 4x
- 2: 5x
- 2A: 6x
- 3: 7x

Europa

- 4: 7x
- 4A: 7x
- 5: 8x
- 6: 8x
- 7: 11x

**HighLine®
Panorama®**

- HS: 7x
- 1: 7x
- 2: 7x
- 3: 7x
- 4: 9x
- 5: 11x
- 6: 16x

AvantGarde®

- A1: 6x
- A2: 6x
- A3: 7x
- A4: 9x
- A5: 7x
- A6: 7x
- A7: 9x
- A8: 12x

Geräteschrank

- Equipment Locker
Armoire à outils
- 90: 4x
 - 150: 4x
 - 190: 6x
 - 230: 6x

MiniGarage

- M: 7x
- L: 7x

NEO

- 1A: 6x
- 2A: 7x
- 1B: 7x
- 2B: 7x

6,3 x 22 *



ⓓ1

Europa

- 1: 4x
- 2: 5x
- 2A: 6x
- 3: 7x

Europa

- 4: 7x
- 4A: 7x
- 5: 8x
- 6: 8x
- 7: 11x

**HighLine®
Panorama®**

- HS: 7x
- 1: 7x
- 2: 7x
- 3: 7x
- 4: 9x
- 5: 11x
- 6: 16x

AvantGarde®

- A1: 6x
- A2: 6x
- A3: 7x
- A4: 9x
- A5: 7x
- A6: 7x
- A7: 9x
- A8: 12x

Geräteschrank

- Equipment Locker
Armoire à outils
- 90: 4x
 - 150: 4x
 - 190: 6x
 - 230: 6x

MiniGarage

- M: 7x
- L: 7x

NEO

- 1A: 6x
- 2A: 7x
- 1B: 7x
- 2B: 7x

M8 x 20



ⓓ1

Europa

- 1: 4x
- 2: 6x
- 2A: 8x
- 3: 10x

Europa

- 4: 10x
- 4A: 10x
- 5: 12x
- 6: 12x
- 7: 18x

**HighLine®
Panorama®**

- HS: 10x
- 1: 10x
- 2: 10x
- 3: 10x
- 4: 14x
- 5: 18x
- 6: 36x

AvantGarde®

- A1: 8x
- A2: 8x
- A3: 10x
- A4: 14x
- A5: 10x
- A6: 10x
- A7: 14x
- A8: 20x

Geräteschrank

- Equipment Locker
Armoire à outils
- 90: 4x
 - 150: 4x
 - 190: 8x
 - 230: 8x

MiniGarage

- M: 10x
- L: 10x

NEO

- 1A: 8x
- 2A: 10x
- 1B: 10x
- 2B: 10x

*Selbstschneidende Schraube
Self-tapping screw - Vis autotaraudeuse

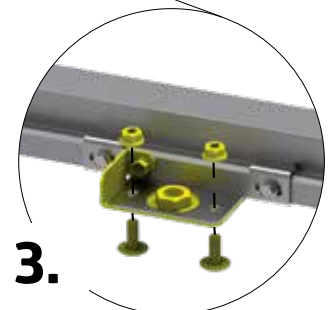
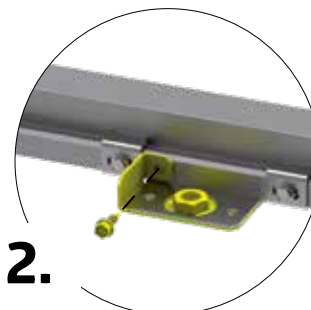
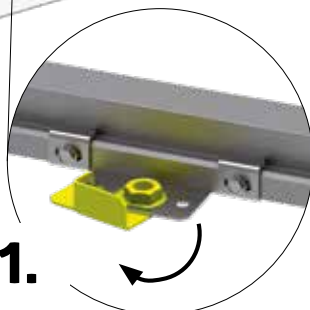
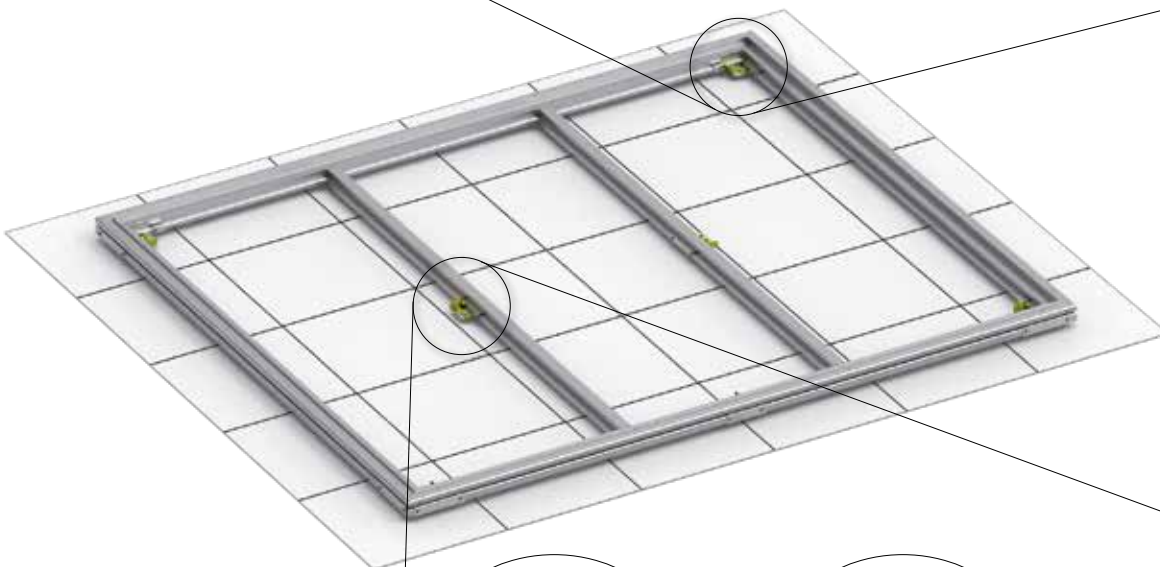
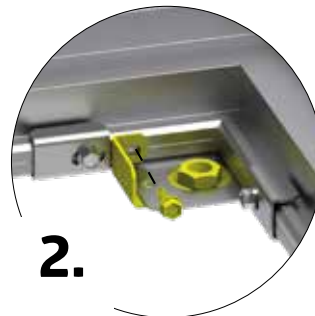
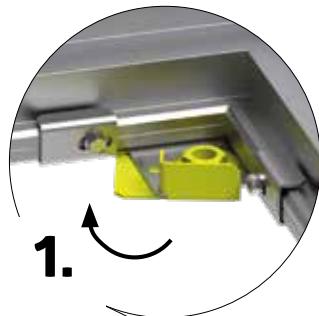

5.



Ⓐ

Europa

- 1: 4x
- 2: 5x
- 2A: 6x
- 3: 7x

Europa

- 4: 7x
- 4A: 7x
- 5: 8x
- 6: 8x
- 7: 11x

**HighLine®
Panorama®**

- HS: 7x
- 1: 7x
- 2: 7x
- 3: 7x
- 4: 9x
- 5: 11x
- 6: 16x

AvantGarde®

- A1: 6x
- A2: 6x
- A3: 7x
- A4: 9x
- A5: 7x
- A6: 7x
- A7: 9x
- A8: 12x

Geräteschrank

Equipment Locker

Armoire à outils

- 90: 4x
- 150: 4x
- 190: 6x
- 230: 6x

MiniGarage

- M: 7x
- L: 7x

NEO

- 1A: 6x
- 2A: 7x
- 1B: 7x
- 2B: 7x

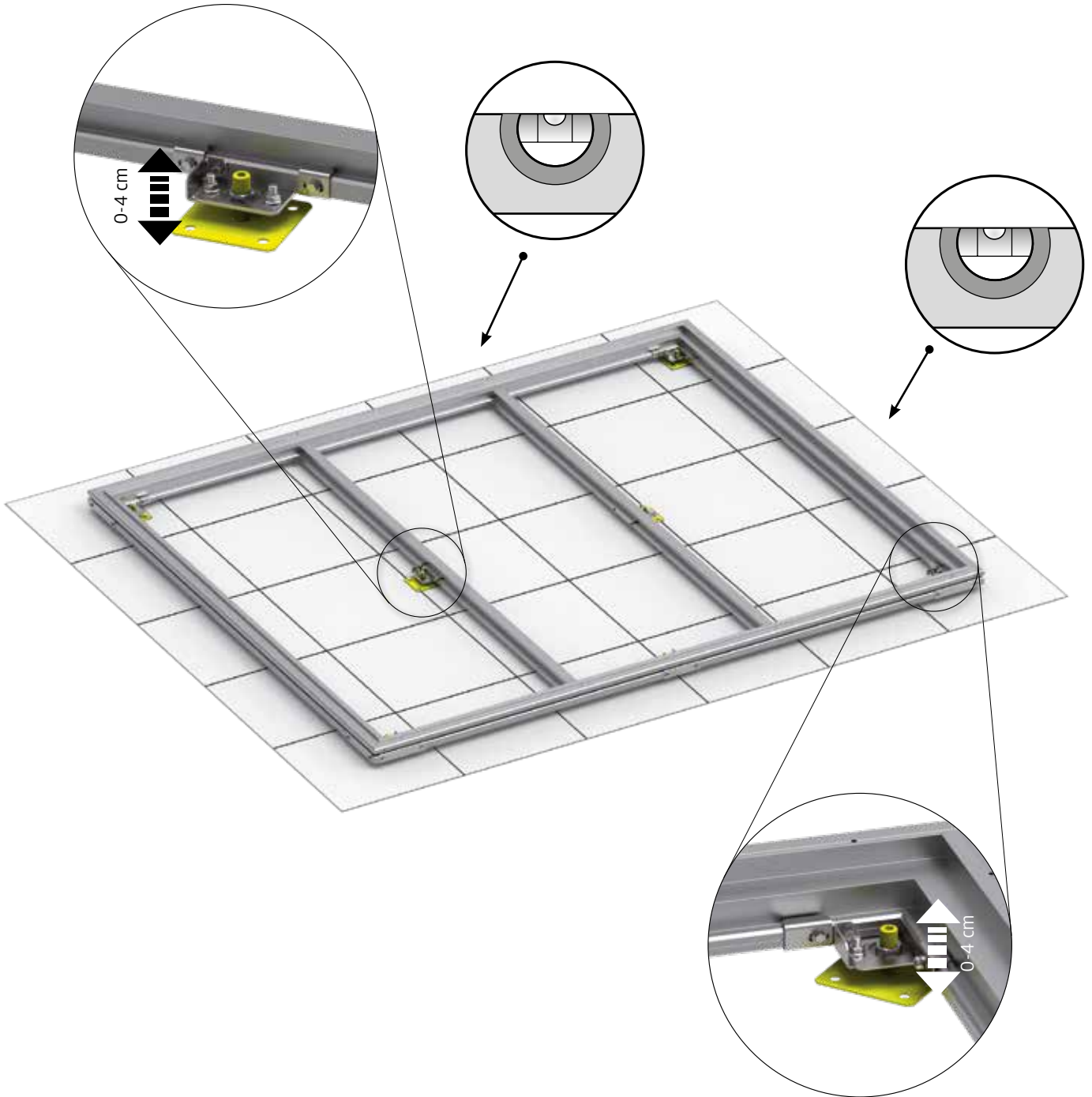

6.

8 x 60



D1

Europa

- 1: 8x
- 2: 10x
- 2A: 12x
- 3: 14x

Europa

- 4: 14x
- 4A: 14x
- 5: 16x
- 6: 16x
- 7: 22x

**HighLine®
Panorama®**

- HS: 14x
- 1: 14x
- 2: 14x
- 3: 14x
- 4: 18x
- 5: 22x
- 6: 32x

AvantGarde®

- A1: 12x
- A2: 12x
- A3: 14x
- A4: 18x
- A5: 14x
- A6: 14x
- A7: 18x
- A8: 24x

Geräteschrank

Equipment Locker

Armoire à outils

- 90: 8x
- 150: 8x
- 190: 12x
- 230: 12x

MiniGarage

- M: 14x
- L: 14x

NEO

- 1A: 12x
- 2A: 14x
- 1B: 14x
- 2B: 14x

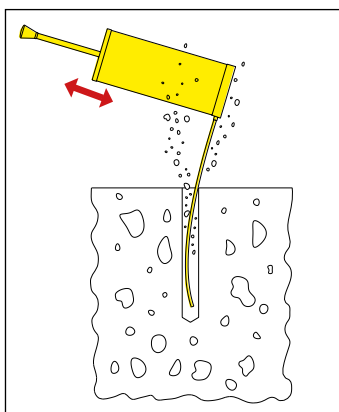
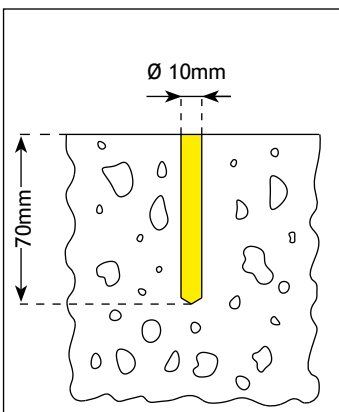
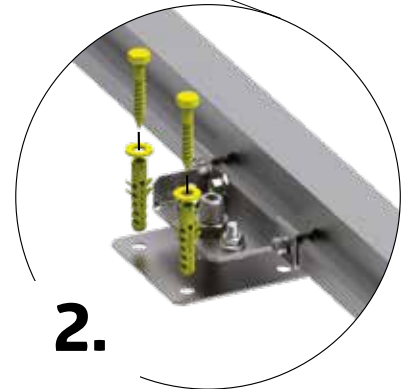
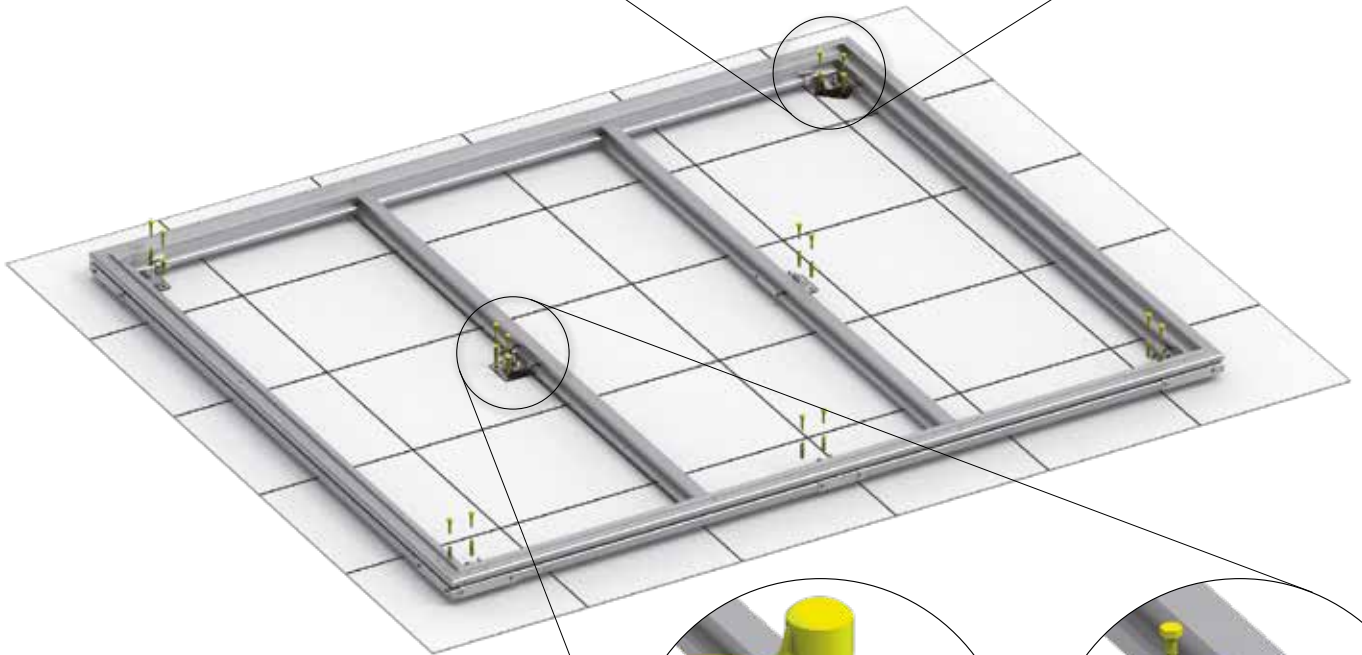
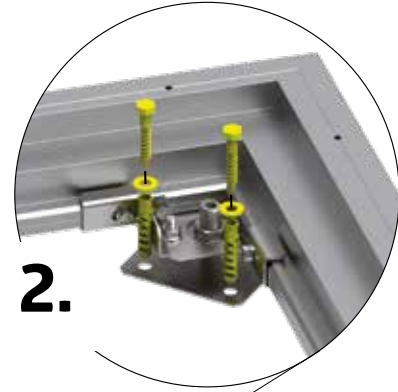
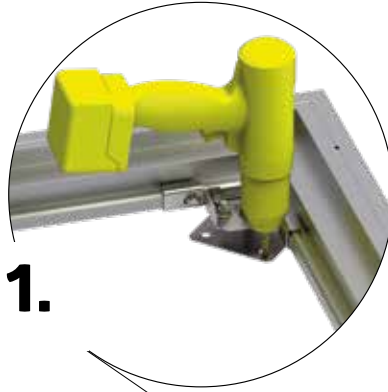

7.

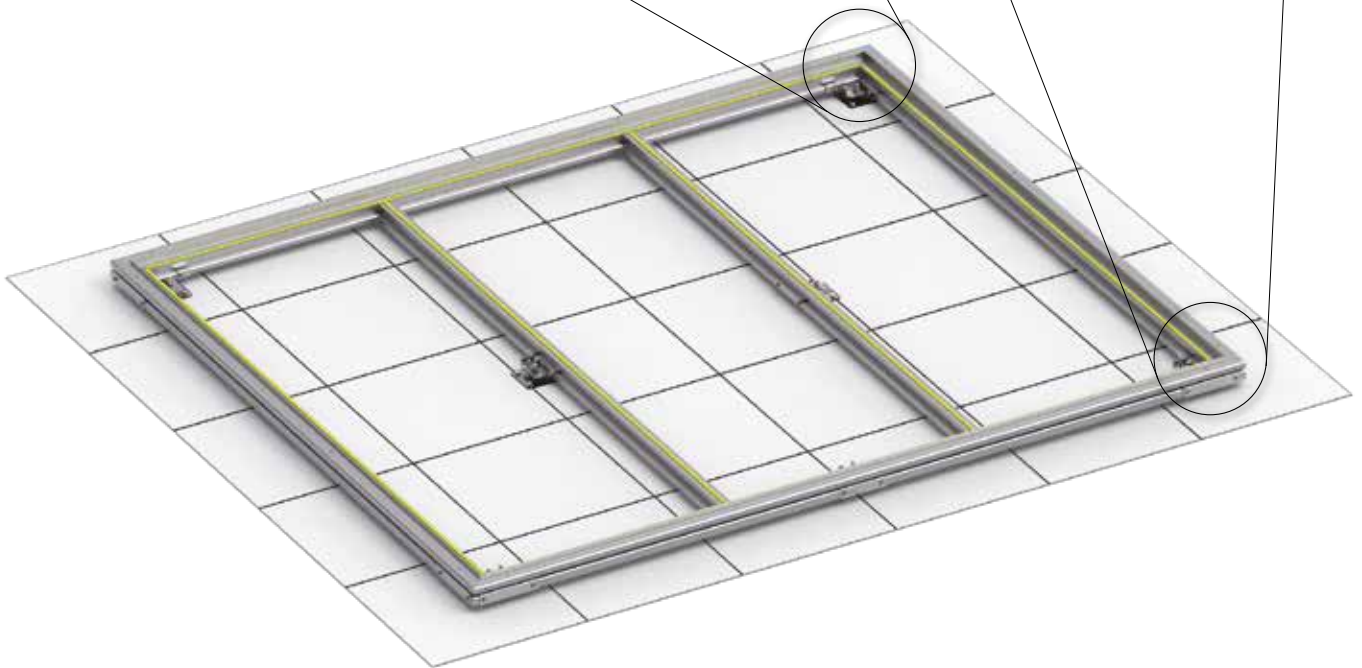
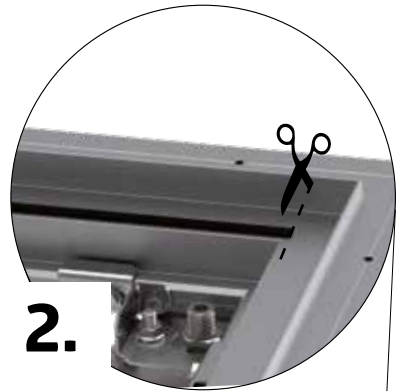
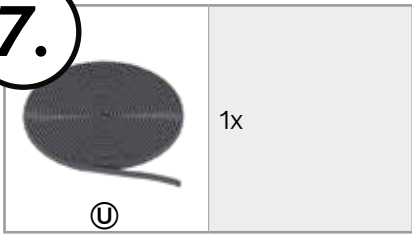

8.

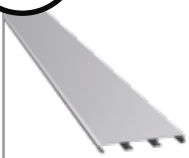

Ⓜ





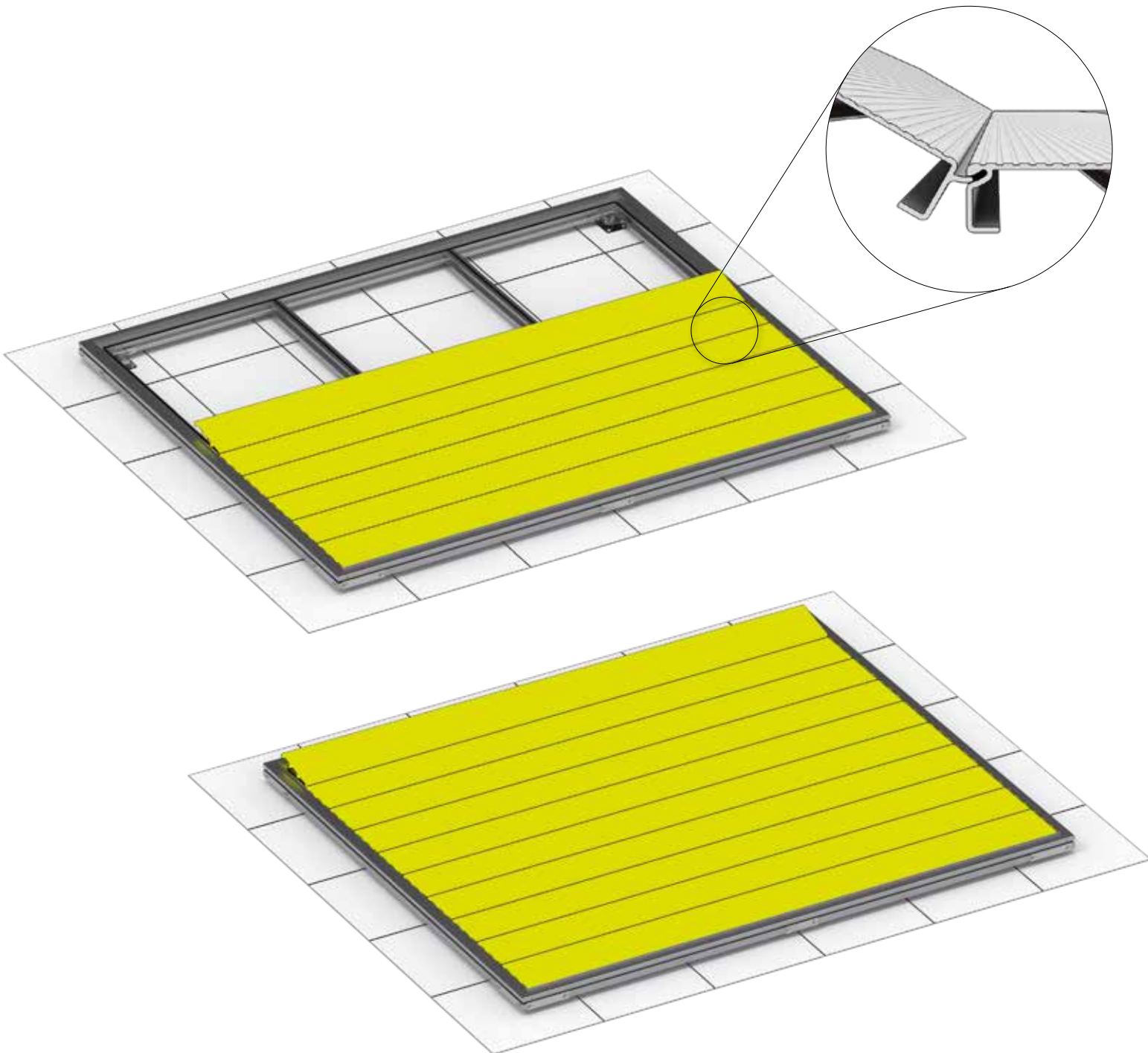

Ⓜ

<p>Europa</p> <p>1: 0X 2: 6X (1400x200mm) 2a: 0X 3: 6X (2120x200mm)</p>	<p>Europa</p> <p>4: 8X (2120x200mm) 4A: 6X (2840x200mm) 5: 8X (2840x200mm) 6: 8X (2840x200mm) 7: 9X (2840x200mm)</p>	<p>HighLine®, Panorama®</p> <p>HS: 6X (2420x200mm) 1: 6X (2420x200mm) 2: 8X (2420x200mm) 3: 10X (2420x200mm) 4: 12X (2420x200mm) 5: 14X (2420x200mm) 6: 14X (2820x200mm)</p>	<p>AvantGarde®</p> <p>A1: 8X (1620x200mm) A2: 10X (1620x200mm) A3: 8X (2420x200mm) A4: 16X (1620x200mm) A5: 8X (2420x200mm) A6: 10X (2420x200mm) A7: 12X (2420x200mm) A8: 16X (2420x200mm)</p>	<p>Geräteschrank Equipment Locker Armoire à outils</p> <p>90: 0X 150: 0X 190: 0X 230: 0X</p>	<p>MiniGarage</p> <p>M: 1X (1880x200mm) L: 3X (1880x200mm)</p> <hr/> <p>NEO</p> <p>1A: 6X (1560x200mm) 2A: 6X (2120x200mm) 1B: 6X (2120x200mm) 2B: 8X (2120x200mm)</p>
<p>Europa</p> <p>1: 4X (1400x170mm) 2: 1X (1400x170mm) 2A: 4X (2120x170mm) 3: 1X (2120x170mm)</p>	<p>Europa</p> <p>4: 3X (2120x170mm) 4A: 1X (2840x170mm) 5: 3X (2840x170mm) 6: 3X (2840x170mm) 7: 6X (2840x170mm)</p>	<p>HighLine®, Panorama®</p> <p>HS: 0X 1: 0X 2: 0X 3: 0X 4: 0X 5: 0X 6: 0X</p>	<p>AvantGarde®</p> <p>A1: 0X A2: 0X A3: 0X A4: 0X A5: 0X A6: 0X A7: 0X A8: 0X</p>	<p>Geräteschrank Equipment Locker Armoire à outils</p> <p>90: 4X (780x170mm) 150: 4X (1400x170mm) 190: 4X (1760x170mm) 230: 4X (2120x170mm)</p>	<p>MiniGarage</p> <p>M: 5X (1880x170mm) L: 4X (1880x170mm)</p> <hr/> <p>NEO</p> <p>1A: 2X (1560x170mm) 2A: 2X (2120x170mm) 1B: 2X (2120x170mm) 2B: 3X (2120x170mm)</p>



9.

 	Europa 1: 2X (684mm) 2: 4X (1404mm) 2A: 2X (684mm) 3: 2X (1404mm)	Europa 4: 4X (2124mm) 4A: 2X (1404mm) 5: 2X (2124mm) 6: 2X (2124mm) 7: 4X (2844mm)	HighLine® Panorama® HS: 2X (1224mm) 1: 2X (1224mm) 2: 2X (1624mm) 3: 2X (2024mm) 4: 4X (2424mm) 5: 2X (2424mm) 6: 4X (2824mm)	AvantGarde® A1: 4X (1624mm) A2: 2X (1624mm) A3: 2X (1624mm) A4: 2X (1624mm) A5: 2X (2424mm) A6: 2X (2424mm) A7: 4X (2424mm) A8: 2X (2424mm)	Geräteschrank Equipment Locker Armoire à outils 90: 2X (684mm) 150: 2X (684mm) 190: 2X (684mm) 230: 2X (684mm)	MiniGarage M: 2X (1884mm) L: 2X (1884mm)
	NEO 1A: 4X (1564mm) 2A: 2X (2124mm) 1B: 2X (2124mm) 2B: 4X (2124mm)					
 	Europa 1: 2X (1404mm) 2: 0X 2A: 2X (2124mm) 3: 2X (2124mm)	Europa 4: 0X 4A: 2X (2844mm) 5: 2X (2844mm) 6: 2X (2844mm) 7: 0X	HighLine® Panorama® HS: 2X (2424mm) 1: 2X (2424mm) 2: 2X (2424mm) 3: 2X (2424mm) 4: 0X 5: 2X (2824mm) 6: 0X	AvantGarde® A1: 0X A2: 2X (2024mm) A3: 2X (2424mm) A4: 2X (3224mm) A5: 2X (1624mm) A6: 2X (2024mm) A7: 0X A8: 2X (3224mm)	Geräteschrank Equipment Locker Armoire à outils 90: 2X (784mm) 150: 2X (1404mm) 190: 2X (1764mm) 230: 2X (2124mm)	MiniGarage M: 2X (1074mm) L: 2X (1304mm)
	NEO 1A: 0X 2A: 2X (1564mm) 1B: 2X (1564mm) 2B: 0X					

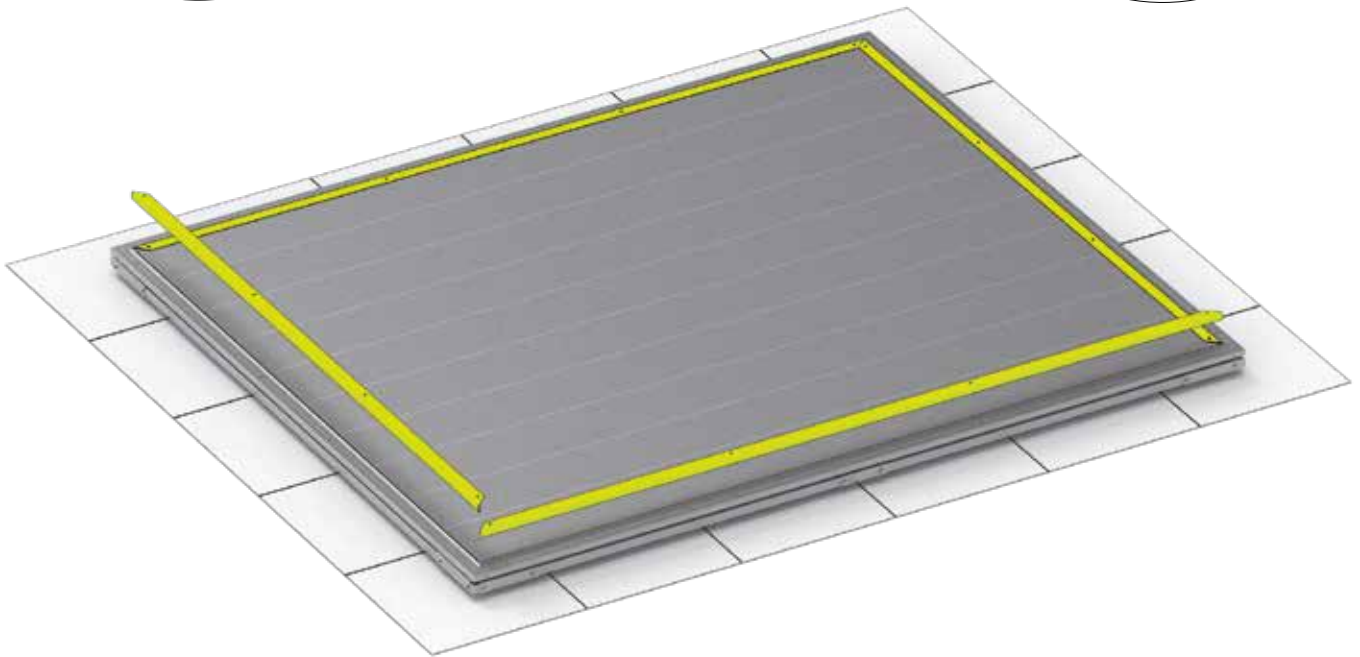
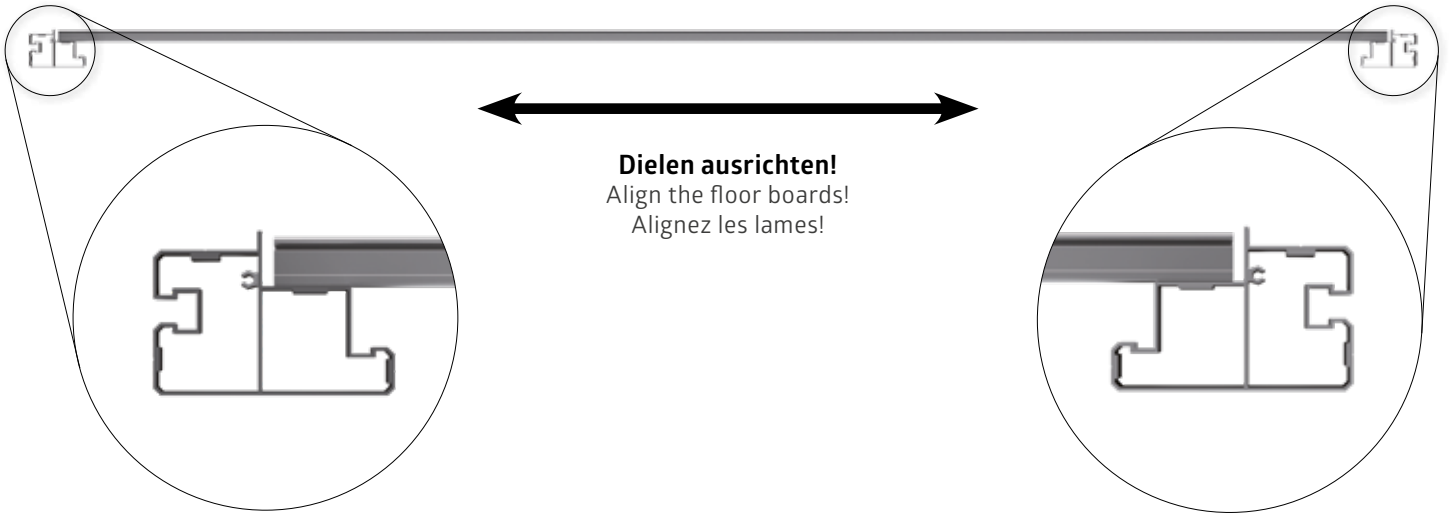

10.

4,8 x 45



D1

Europa	Europa	HighLine® Panorama®	AvantGarde®	Geräteschrank Equipment Locker Armoire à outils	MiniGarage
1: 12x 2: 16x 2A: 12x 3: 16x	4: 16x 4A: 20x 5: 20x 6: 20x 7: 24x	HS: 16x 1: 16x 2: 16x 3: 16x 4: 16x 5: 20x 6: 24x	A1: 16x A2: 16x A3: 16x A4: 20x A5: 16x A6: 16x A7: 16x A8: 20x	90: 8x 150: 12x 190: 12x 230: 12x	M: 14x L: 14x
					NEO
					1A: 12x 2A: 14x 1B: 14x 2B: 16x

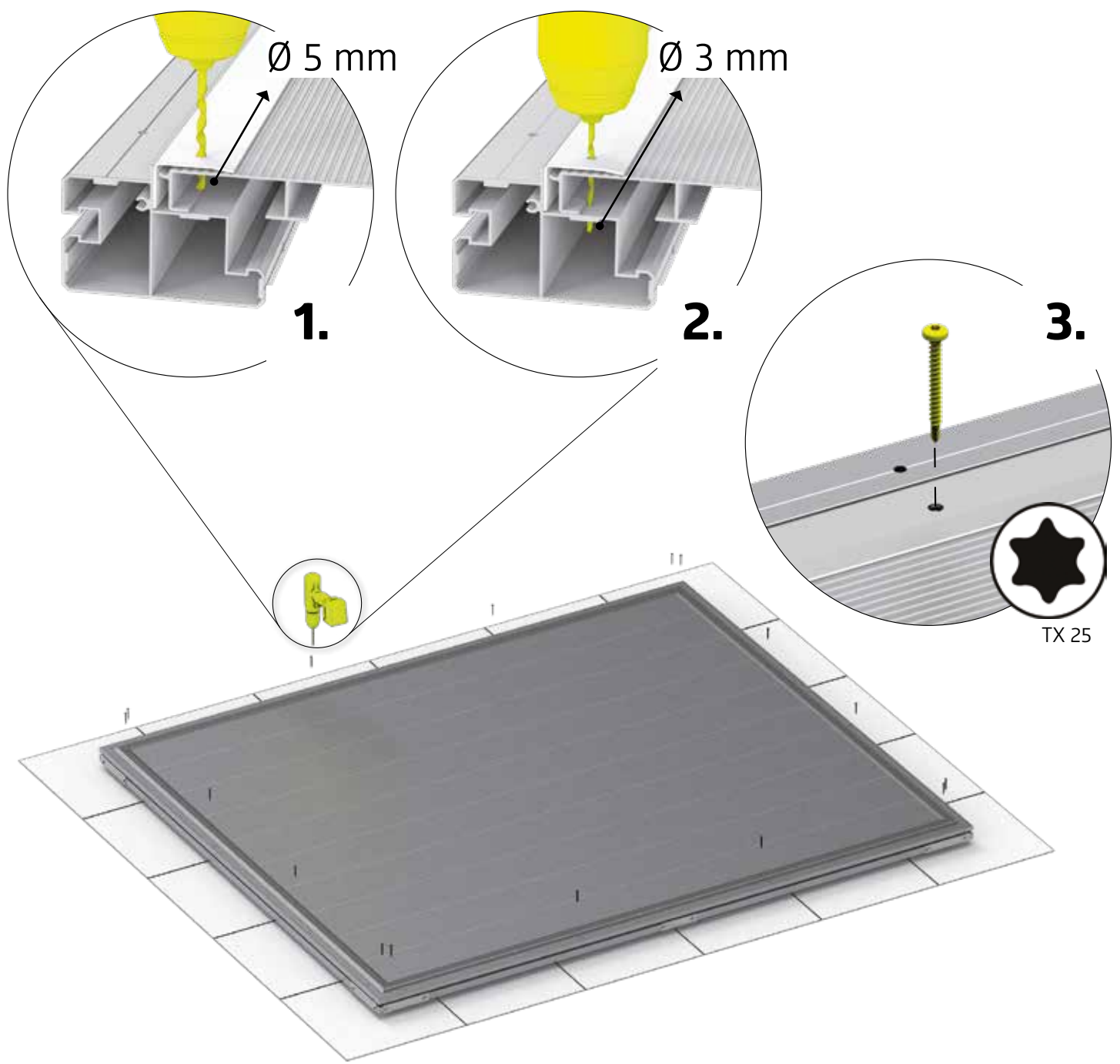

11.

22 x 2



D1

Europa
 1: 14x
 2: 20x
 2A: 14x
 3: 20x

Europa
 4: 20x
 4A: 20x
 5: 20x
 6: 20x
 7: 20x

**HighLine®
 Panorama®**
 HS: 14x
 1: 14x
 2: 18x
 3: 16x
 4: 16x
 5: 18x
 6: 24x

AvantGarde®
 A1: 20x
 A2: 18x
 A3: 18x
 A4: 20x
 A5: 18x
 A6: 16x
 A7: 16x
 A8: 20x

Geräteschrank
 Equipment Locker
 Armoire à outils
 90: 8x
 150: 14x
 190: 10x
 230: 14x

MiniGarage
 M: 14x
 L: 14x
NEO
 1A: 0x
 2A: 0x
 1B: 0x
 2B: 0x

6,3 x 22 *



D1

Europa
 1: 14x
 2: 20x
 2A: 14x
 3: 20x

Europa
 4: 20x
 4A: 20x
 5: 20x
 6: 20x
 7: 20x

**HighLine®
 Panorama®**
 HS: 14x
 1: 14x
 2: 18x
 3: 16x
 4: 16x
 5: 18x
 6: 24x

AvantGarde®
 A1: 20x
 A2: 18x
 A3: 18x
 A4: 20x
 A5: 18x
 A6: 16x
 A7: 16x
 A8: 20x

Geräteschrank
 Equipment Locker
 Armoire à outils
 90: 8x
 150: 14x
 190: 10x
 230: 14x

MiniGarage
 M: 14x
 L: 14x
NEO
 1A: 16x
 2A: 14x
 1B: 14x
 2B: 12x

*Selbstschneidende Schraube
 Self-tapping screw - Vis autotaraudeuse

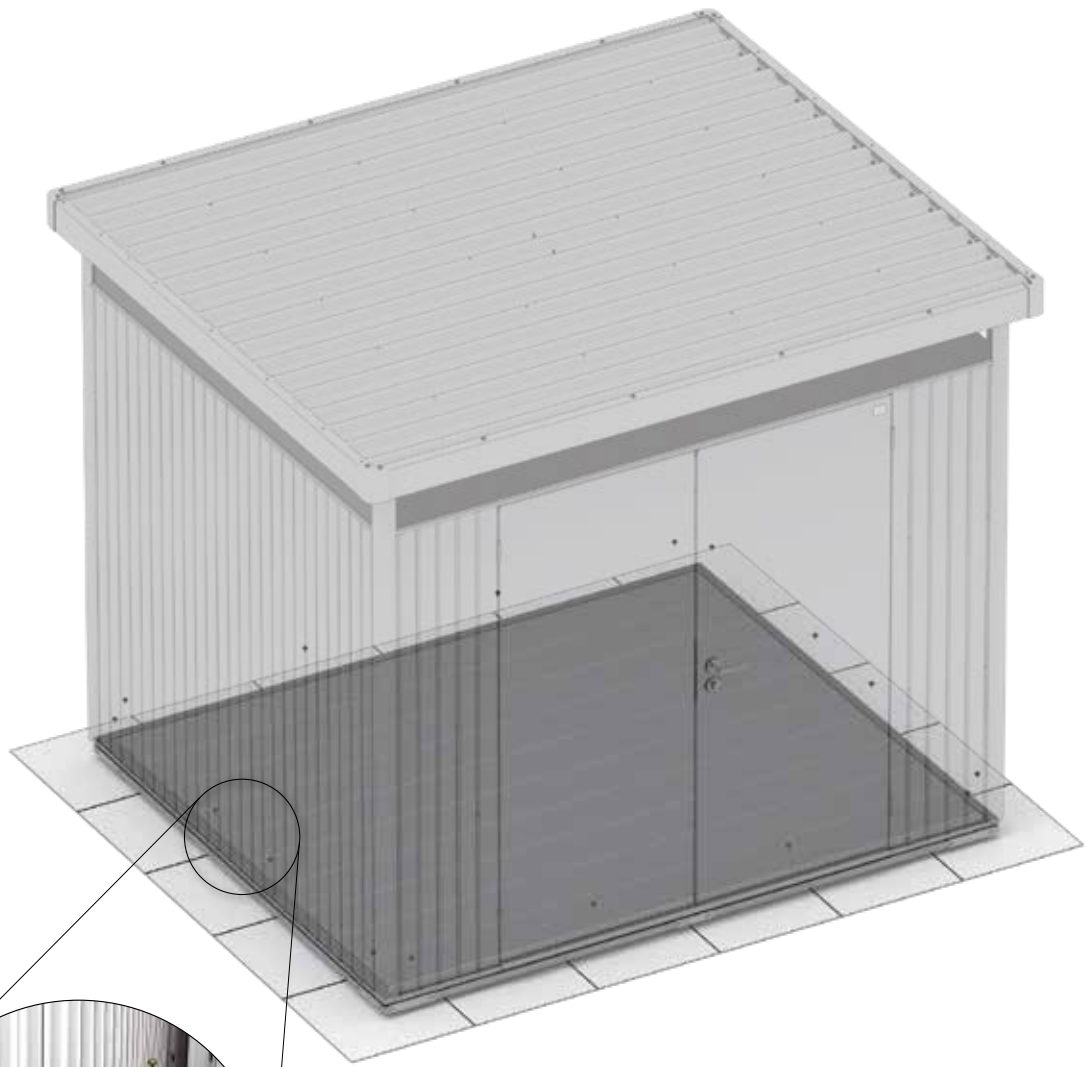



GERÄTEHÄUSER – Setzen Sie auf Qualität & Langlebigkeit
GARDEN SHEDS – rely on quality & longevity



GARTENBOXEN – Outdoorboxen für Garten, Terrasse & Co.
OUTDOOR BOXES – outdoor boxes for garden, patio & more



FAHRRAD-GARAGEN – Fahrräder, Roller & Co sicher verstaut
BICYCLE STORAGE – for safe storage of bicycles, scooters & more



MÜLLTONNEN-BOXEN – Stylish, praktisch & wartungsfrei
DUSTBIN STORAGE – stylish, practical & maintenance free



GARTEN-HELFER – Gartendesign in Bestform
GARDENING HELPERS – garden design at its best

Kontrollnummer:
 Control-number / Contrôle-Qualité / Controlnummer:



Bei Reklamationen bitte anführen:
 Kontrollnummer und Artikelnummer des reklamierten Teils.

GB: In case of complaint please indicate the control-number and the number of the item, which is subject of complaint.

F: Pour toutes réclamations: prière de joindre le numéro de contrôle et le numéro d'article de la pièce litigieuse.

NL: Bij reclamaties svp doorgeven: controlnummer en artikelnummer van het desbetreffende onderdeel.



Biohort steht für
 „LEBEN IM GARTEN“

Biohort stands for
 „LIFE IN THE GARDEN“

follow us:



Biohort GmbH
 Pürnstern 43, 4120 Neufelden, Österreich
 Tel: +43-7282-7788-0
 E-Mail: office@biohort.at, www.biohort.com