

92972 92972

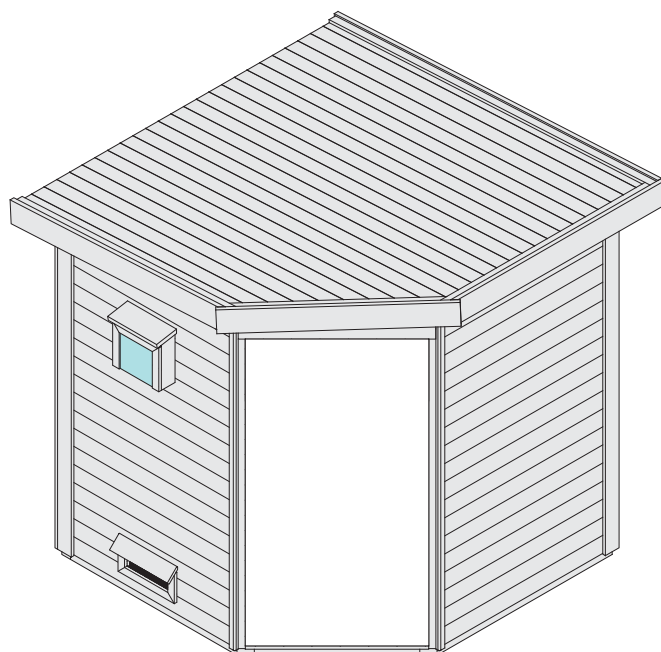

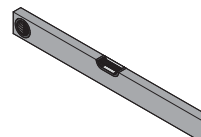

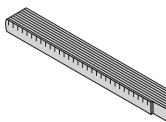
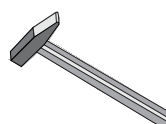
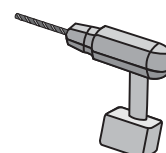
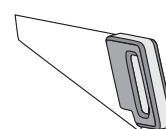

-  **Aufbauanleitung**
-  **Building Instructions**
-  **notice de montage**
-  **montagehandleiding**
-  **Montagevejledning**
-  **Instrucciones de construcción**
-  **Istruzioni per il montaggio**
-  **Montážní návod**











Bitte bewahren Sie die Anleitung und den Garantieschein zur Seriennummer auf.  
Vernichten Sie diese erst nach Ablauf der Garantiezeit.  
Eventuelle Beanstandungen können mithilfe der Stückliste einfacher zugeordnet werden.





#### Beigelegte Dokumente

- Informationsheft
- Garantieschein zur Seriennummer
- Typenschild inkl. Warnhinweise (Sauna)
- ggf. Zubehör-Anleitungen in externen Paketen





- \*  Nicht im Lieferumfang enthalten  
 Not included  
 Non comprises dans la livraison  
 Niet bijgeleverd

-  No forman parte del suministro  
 Non incluso  
 V ceně není zahrnuto  
 Ikke inkluderet

- 1  Länge muss ermittelt und zugesägt werden  
 Length must be determined and sawn  
 La longueur doit être déterminée et sciée  
 De lengte moet worden bepaald en worden gezaagd

-  La longitud debe ser determinada y aserrada  
 La lunghezza deve essere determinata e segata  
 Délka musí být určena a rozřezána  
 Længden skal bestemmes og savnes





- 2  Nicht gebraucht  
 Not needed  
 Pas nécessaire  
 Niet nodig

-  No es necesario  
 Non necessario  
 Není nutná  
 Ikke nødvendigt





- 3  Mit Zubehör  
 With accessories  
 Avec accessoires  
 Met toebehoren

-  Con accesorios  
 Con accessori  
 S příslušenstvím  
 Med tilbehør

- 4  Fixiert vorübergehend  
 Fixed temporarily  
 Temporairement fixe  
 Tijdelijk vast

-  Temporalmente fijo  
 Temporaneamente fisso  
 Dočasně pevný  
 Midlertidigt rettet

- 5  Bestand vom Haus  
 Inventory of the house  
 Inventaire de la maison  
 Inventaris van het huis

-  Inventario de la casa  
 Inventario della casa  
 Inventář domu  
 Inventar af huset

Werkzeuge / Tools\*

X

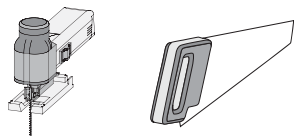

X

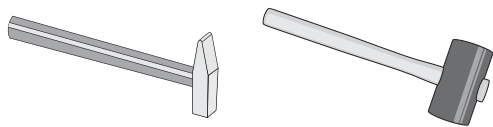

X

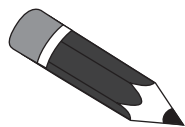

X

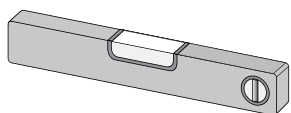

X

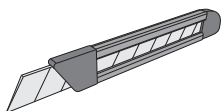

X

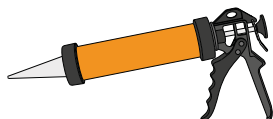
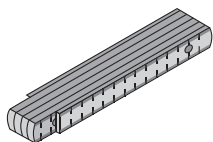

X

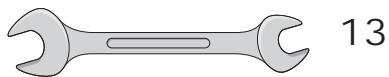
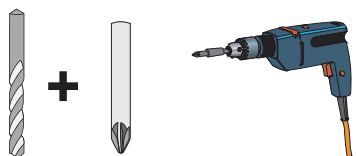

X

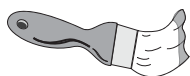

X



Technische Daten

In der Auftragsbestätigung bzw. Lieferschein ist der gekaufte Ofentyp bzw. das erworbene Steuergerät zu finden. Bitte entnehmen Sie die technischen Daten Ihrer Geräte der folgenden Auflistung

Gerät	Netzspannung	Wattage
<b>Öfen</b>		
9kW Ofen Bio	400V ~ 3N	9kW
9kW Ofen (Finnisch)	400V ~ 3N	9kW
9kW Ofen integr. Steuerung	400V ~ 3N	9kW
4,5kW Ofen Bio	400V ~ 3N	4,5kW
4,5kW Ofen (Finnisch)	400V ~ 3N	4,5kW
4,5kW Ofen integr. Steuerung	400V ~ 3N	4,5kW
3,6kW Ofen Bio	230V ~ 1N	3,6kW
3,6kW Ofen (Finnisch)	230V ~ 1N	3,6kW
3,6kW Ofen integr. Steuerung	230V ~ 1N	3,6kW
<b>Steuergeräte</b>		
externe Steuerung Easy Bio	400V ~ 3N	max. 10,8kW
externe Steuerung Plug&Play Bio	240V ~ 3N	max. 10,8kW
externe Steuerung (Finnisch)	400V ~ 3N	max. 10,8kW
externe Steuerung Plug&Play (Finnisch)	240V ~ 3N	max. 10,8kW
Multisteuergerät	400V ~ 3N	max. 10,5kW
externe Steuerung Classic Bio	400V ~ 3N	max. 9kW
externe Steuerung Classic (Finnisch)	400V ~ 3N	max. 9kW
externe Steuerung Premium Bio	400V ~ 3N	max. 12kW
externe Steuerung Premium (Finnisch)	400V ~ 3N	max. 9kW



Vergleichen Sie zuerst die Material-liste mit Ihrem Paketinhalt! Bitte haben Sie Verständnis, dass Beanstandungen nur im nicht aufgebauten Zustand bearbeitet werden können!



Vergelijk eerst de lijst van materialen met de inhoud van uw pakket! Reclamaties kunnen alleen in behandeling worden genomen zolang de onderdelen nog niet zijn gemonteerd!



Confrontate questa distinta materiali prima con il contenuto del pacchetto! Vi preghiamo di comprendere che eventuali reclami possono essere accolti solo prima del montaggio!



First compare the list of materials with your package contents! Please understand that complaints can be processed in the non-built status only!



Start med at kontrollere materialelisten med indholdet af den leverede pakke! Vi gør venligst opmærksom på at reklamationer kun kan behandles for materialer som ikke er blevet bearbejdet!



Nejprve přezkontrolujte obsah balení podle materiálového listu! Mějte pochopení pro to, že případnou reklamaci se můžeme zabývat pouze tehdy, když díly nebudou smontované! Za pomoci tohoto seznamu můžete jednotlivé díly přiřadit k montážnímu návodu.



Commencez par comparer la liste du matériel avec le contenu de votre paquet! Sachez que nous traitons uniquement les réclamations concernant le matériel à l'état non monté!



En primer lugar, compare la lista de material con el contenido del paquete. Rogamos entienda que las reclamaciones sólo pueden ser tramitadas antes de montar el objeto!

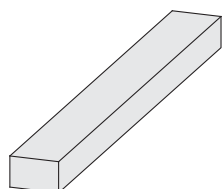
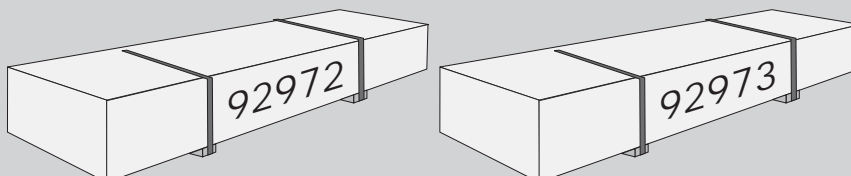

1 x B1	1920 x	20 x	3 mm	ID 20799
2 x B2	1810 x	90 x	16 mm	ID 71513
2 x B3	800 x	45 x	18 mm	ID 24796
2 x B4	906 x	45 x	18 mm	ID 27383
5 x B5	2100 x	45 x	18 mm	ID 19547
1 x B6	300 x	95 x	18 mm	ID 19130
4 x B7	480 x	95 x	18 mm	ID 20930
4 x B8	565 x	95 x	18 mm	ID 15498
6 x B9	2300 x	95 x	18 mm	ID 16177
1 x B10	1210 x	140 x	26 mm	ID 36420
1 x B11	2250 x	140 x	26 mm	ID 50192
4 x B12	1756 x	38 x	28 mm	ID 20699
2 x B13	800 x	58 x	28 mm	ID 15493
1 x B14	946 x	58 x	28 mm	ID 21156
2 x B15	1853 x	45 x	38 mm	ID 27380
3 x B16	1790 x	60 x	40 mm	ID 63757
1 x B17	1910 x	60 x	40 mm	ID 29452
3 x B18	2160 x	45 x	45 mm	ID 59218

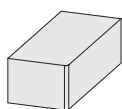

4 x S1	60 x	36 x	36 mm	ID 5512
--------	------	------	-------	---------

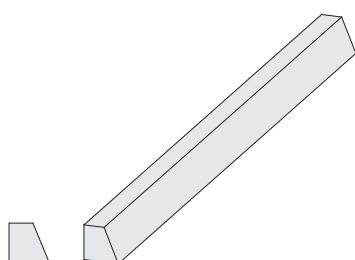

2 x F1	2175 x	25 x	38 mm	ID 27378
2 x F2	2175 x	45 x	38 mm	ID 27377

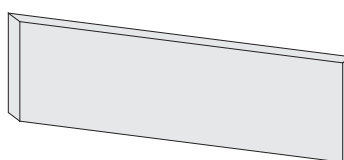

2 x C1	1470 x	140 x	26 mm	ID 70397
--------	--------	-------	-------	----------

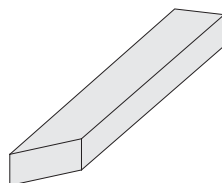

1 x C2	1216 x	60 x	40 mm	ID 70403
1 x C3	1276 x	60 x	40 mm	ID 70406

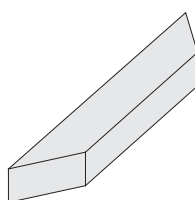

1 x C4	932 x	60 x	40 mm	ID 70414
--------	-------	------	-------	----------

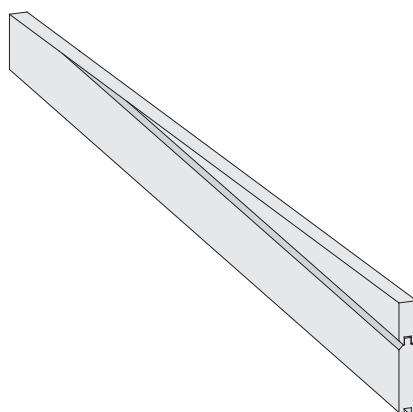

1 x G1	1141 x	162 x	38 mm	ID 27370
1 x G2	1845 x	200 x	38 mm	ID 27372

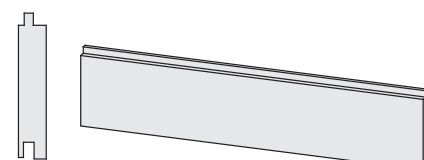

21 x R1	1845 x	96 x	19 mm	ID 18474
26 x R2	2240 x	96 x	19 mm	ID 42283

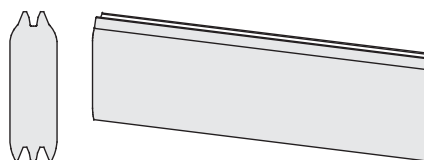

1 x W1	424 x	121 x	38 mm	ID 48175
1 x W2	442 x	121 x	38 mm	ID 24193
3 x W3	996 x	121 x	38 mm	ID 27374
37 x W4	1141 x	121 x	38 mm	ID 27371
36 x W5	1845 x	121 x	38 mm	ID 70465

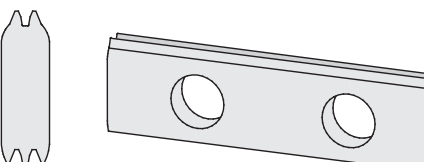

1 x W6	1845 x	121 x	38 mm	ID 5968
--------	--------	-------	-------	---------

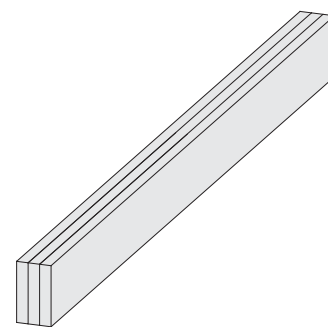

7 x P1	150 x	95 x	54 mm	ID 63278
2 x P2	1843 x	95 x	54 mm	ID 22596



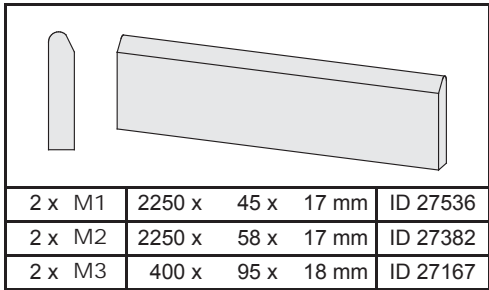

2 x M1	2250 x	45 x	17 mm	ID 27536
2 x M2	2250 x	58 x	17 mm	ID 27382
2 x M3	400 x	95 x	18 mm	ID 27167

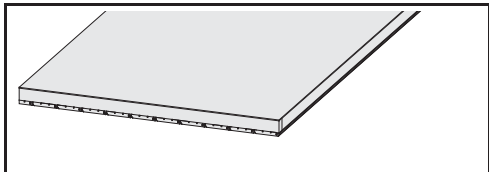

1 x N1	1839 x	918 x	57 mm	ID 5986
--------	--------	-------	-------	---------

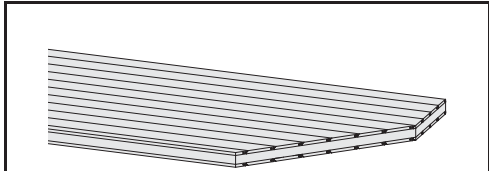

1 x N2	1839 x	918 x	57 mm	ID 27368
--------	--------	-------	-------	----------

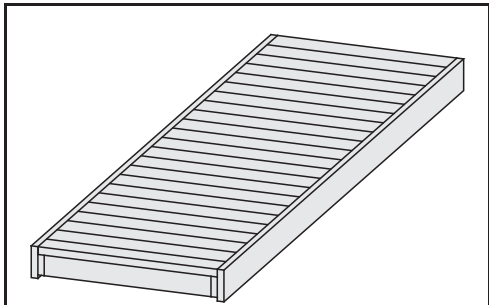

2 x L1	1810 x	550 x	95 mm	ID 43994
--------	--------	-------	-------	----------

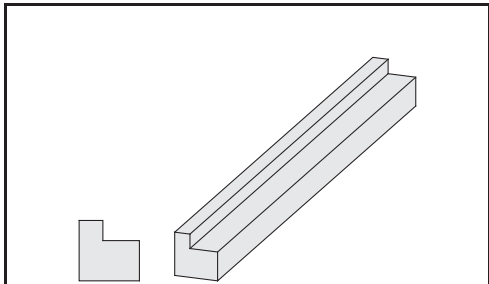

2 x L2	555 x	45 x	45 mm	ID 40301
2 x L3	1100 x	45 x	45 mm	ID 40302

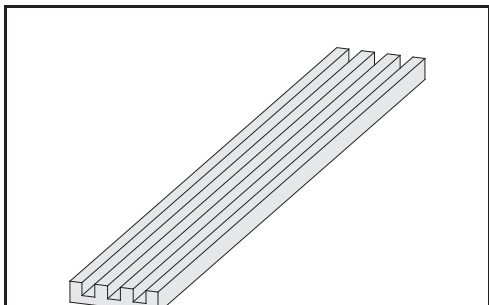

1 x E1	1820 x	140 x	26 mm	ID 26480
--------	--------	-------	-------	----------

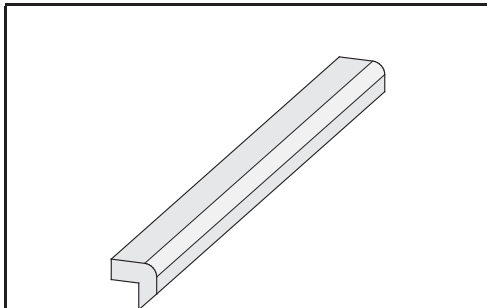

1 x E2	960 x	52 x	23 mm	ID 22599
--------	-------	------	-------	----------

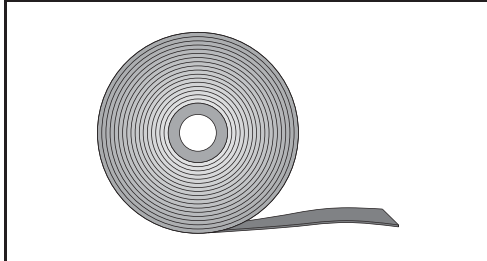

10 m				ID 14025
------	--	--	--	----------

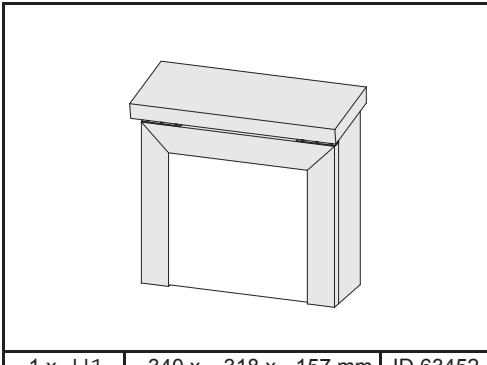

1 x H1	340 x	318 x	157 mm	ID 63452
--------	-------	-------	--------	----------

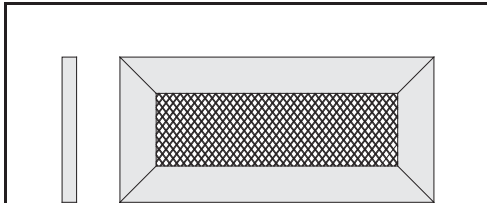

2 x H2				ID 86726
--------	--	--	--	----------



1 x				ID 71504
-----	--	--	--	----------

25 x	4 x 30 mm	ID 3686
130 x	4 x 35 mm	ID 3687
95 x	4 x 40 mm	ID 21925
100 x	4 x 50 mm	ID 3688
20 x	4,5 x 80 mm	ID 9204
350 x	5 x 70 mm	ID 93009
2 x	6 x 60 mm	ID 14014
16 x	6 x 80 mm	ID 47558
16 x	6 x 100 mm	ID 11749

400 x		ID 5621

8 x		ID 21292



1 x		ID 15979

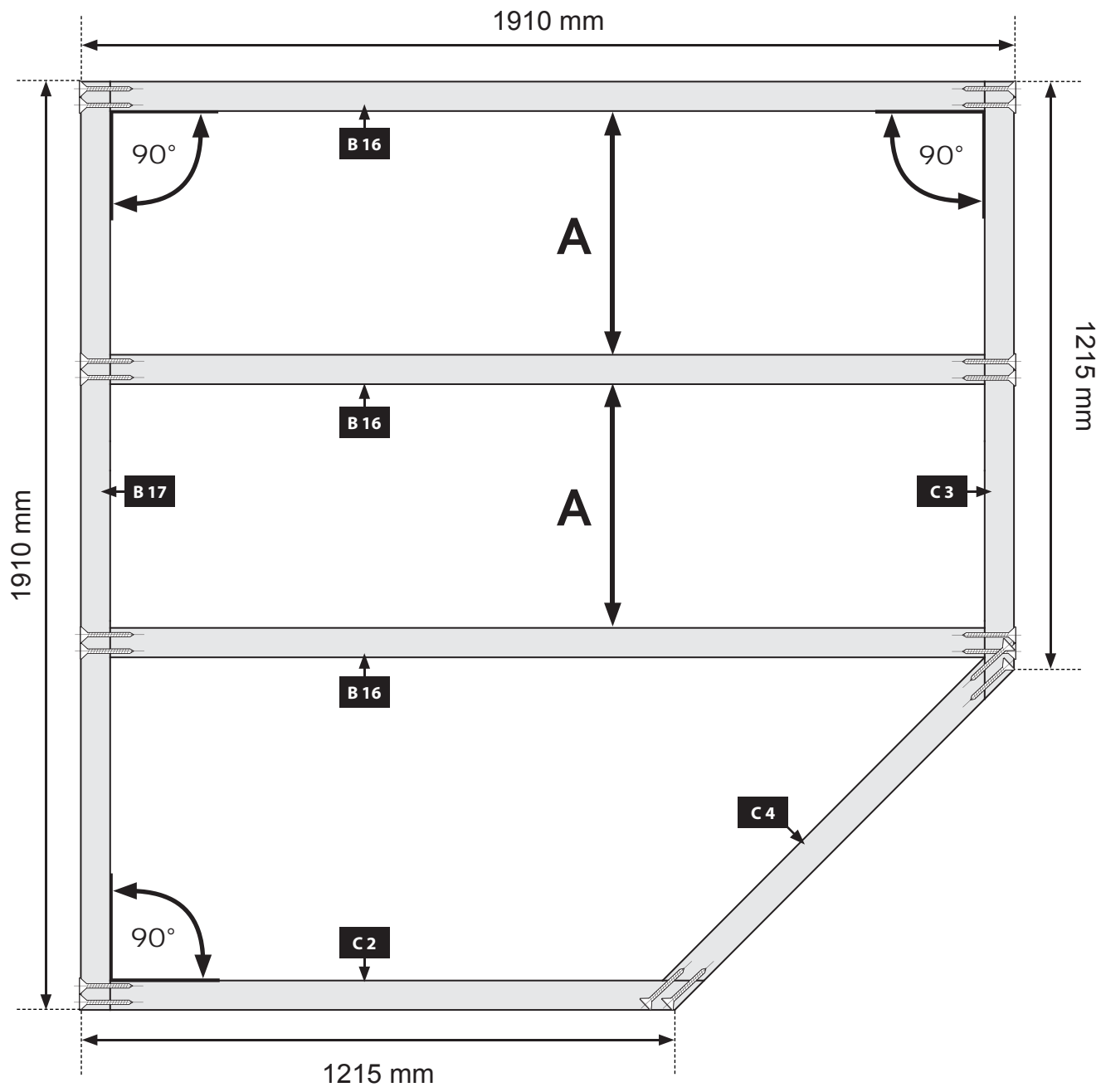
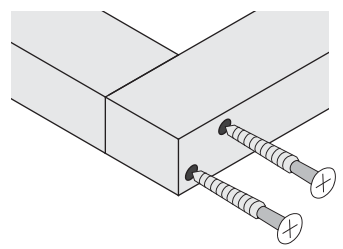
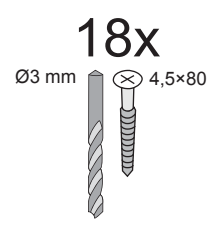
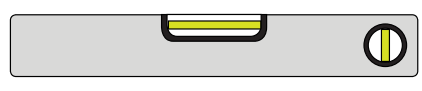

5 x	3 x 16mm	ID 46376

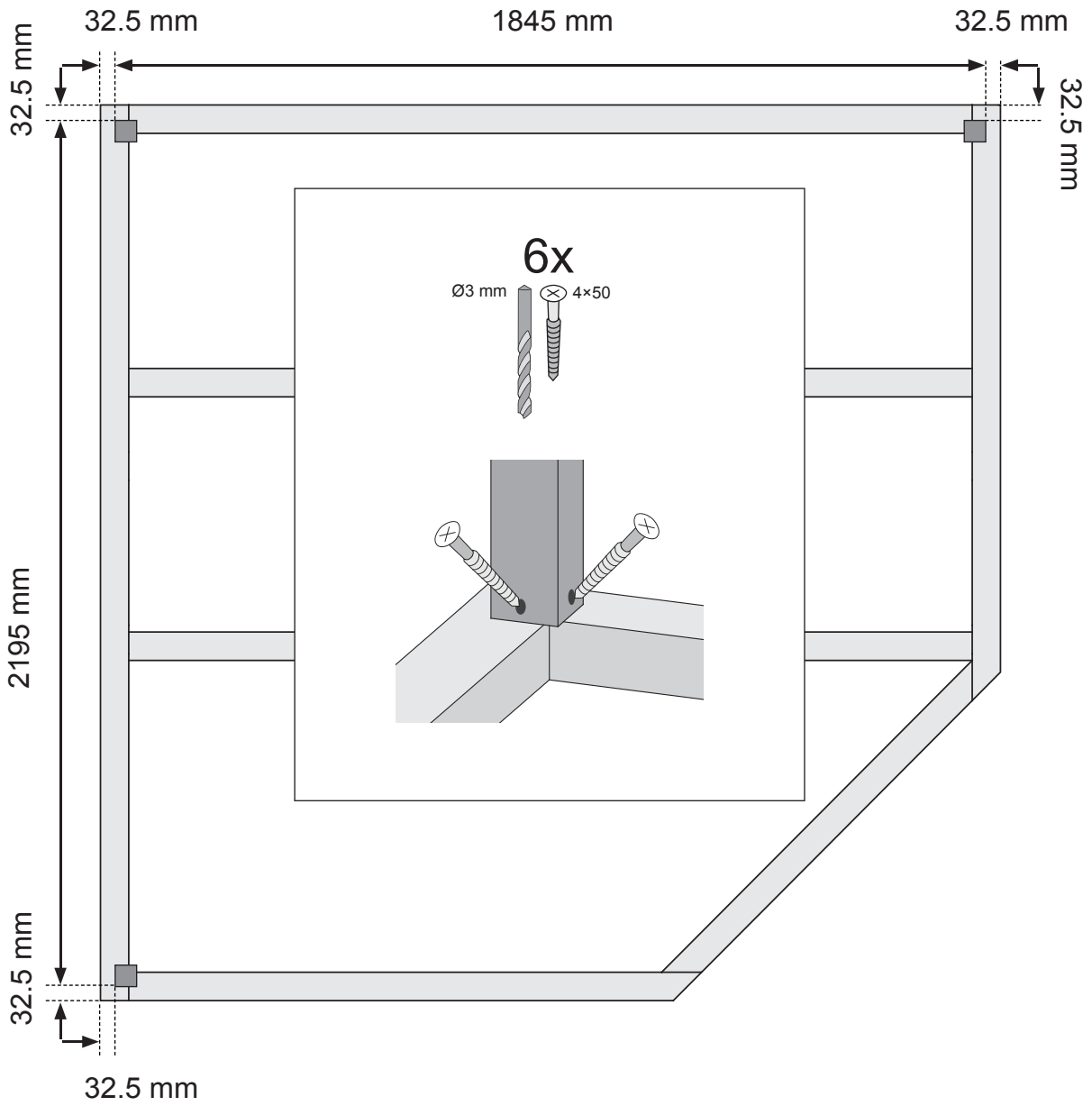
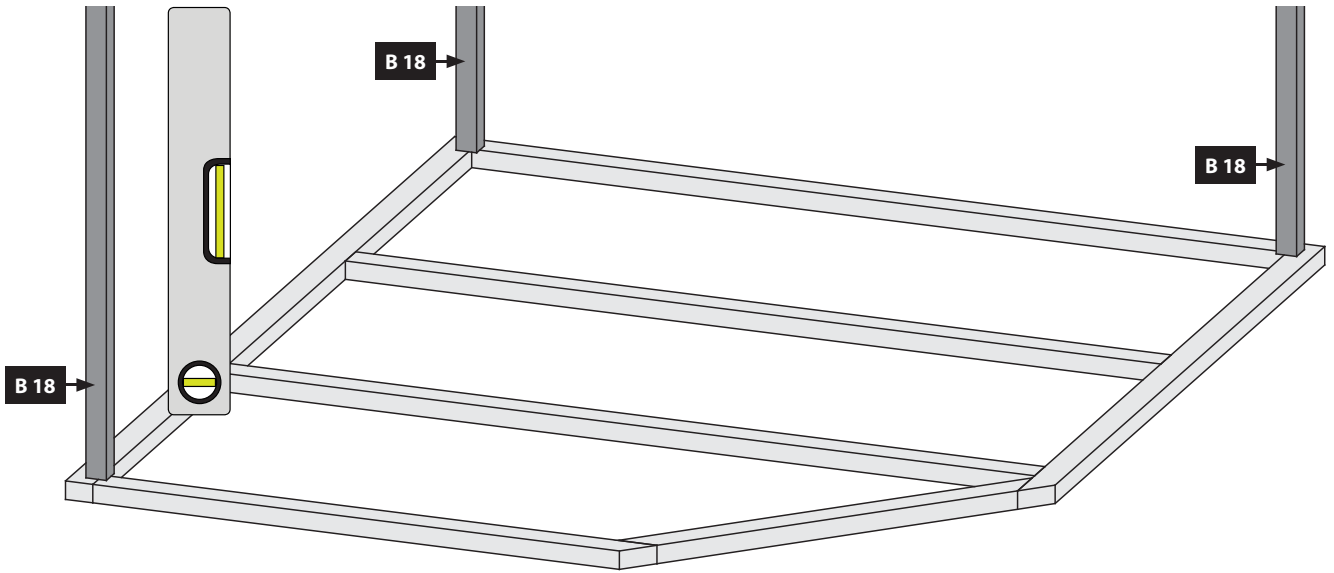

1 x		ID 50420





 Leim! Achten Sie auf die gleiche Höhe  
 Glue! Look for the same height  
 Colle! Faites attention à la même hauteur

 Lijm! Besteed aandacht aan de dezelfde hoogte  
 Lim! Vær opmærksom på samme højde  
 Pegamento! Prestar atención a la misma altura

 Colla! Prestare attenzione alla stessa altezza  
 Klíh! Dávejte pozor na stejnou výšku





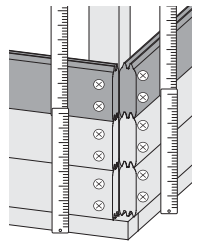
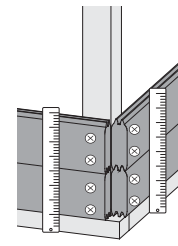
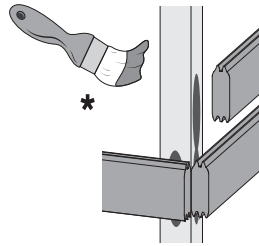
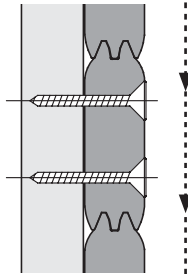
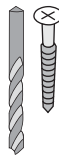

Ø4 mm 5x70

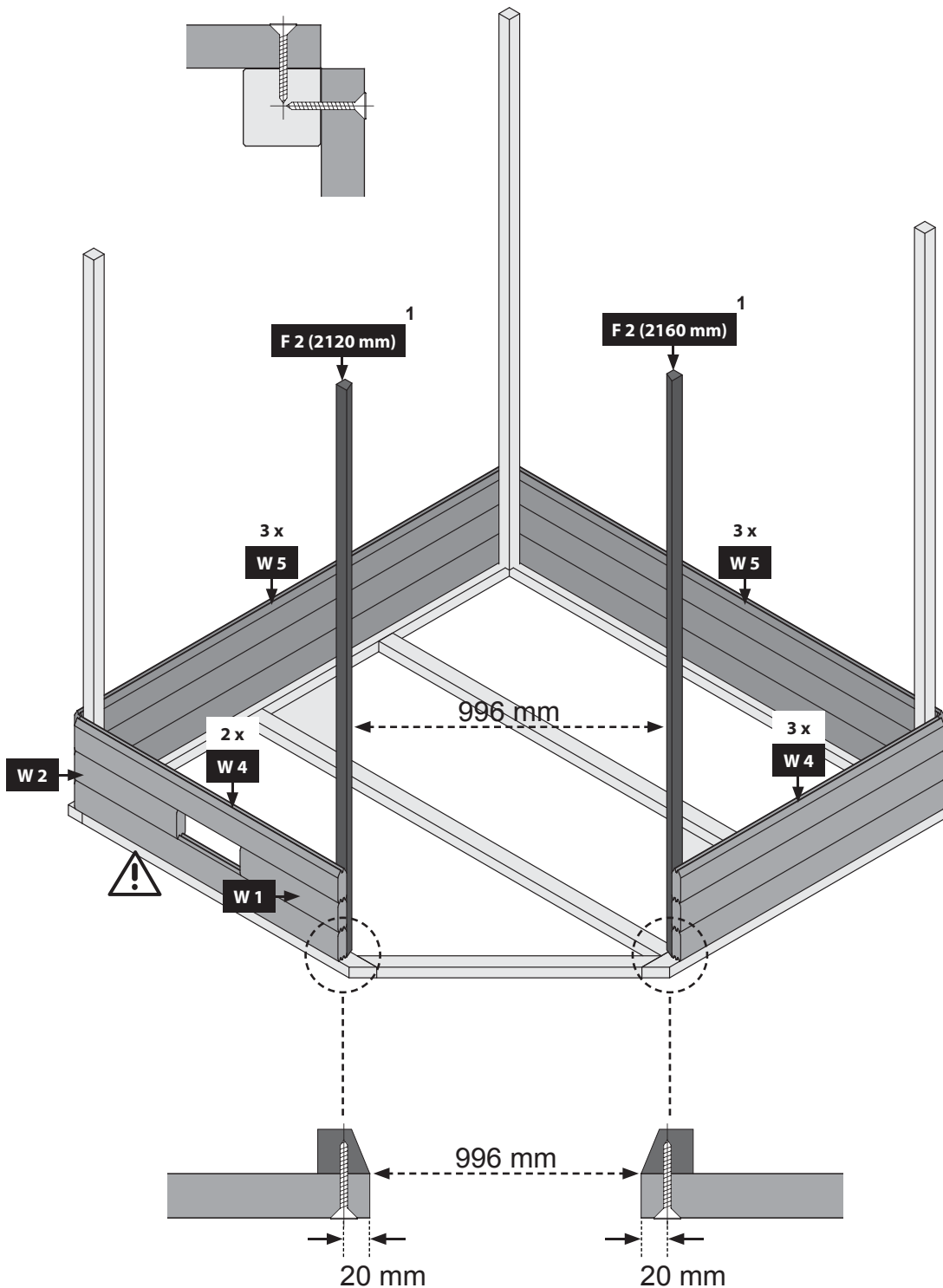

48x





03



 Leim! Achten Sie auf die gleiche Höhe  
 Glue! Look for the same height  
 Colle! Faites attention à la même hauteur

 Lijm! Besteed aandacht aan de dezelfde hoogte  
 Lim! Vær opmærksom på samme højde  
 Pegamento! Prestar atención a la misma altura

 Colla! Prestare attenzione alla stessa altezza  
 Klíh! Dávejte pozor na stejnou výšku



Ø4 mm 5×70

240x

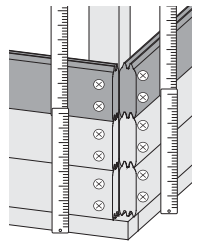
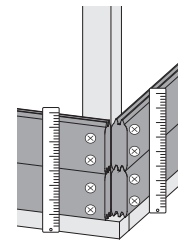
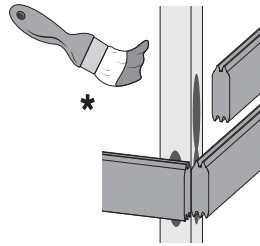
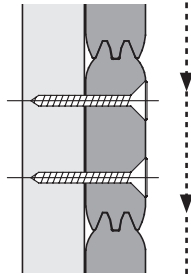
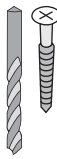

04

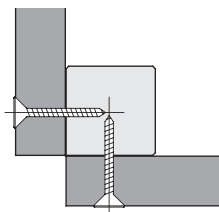
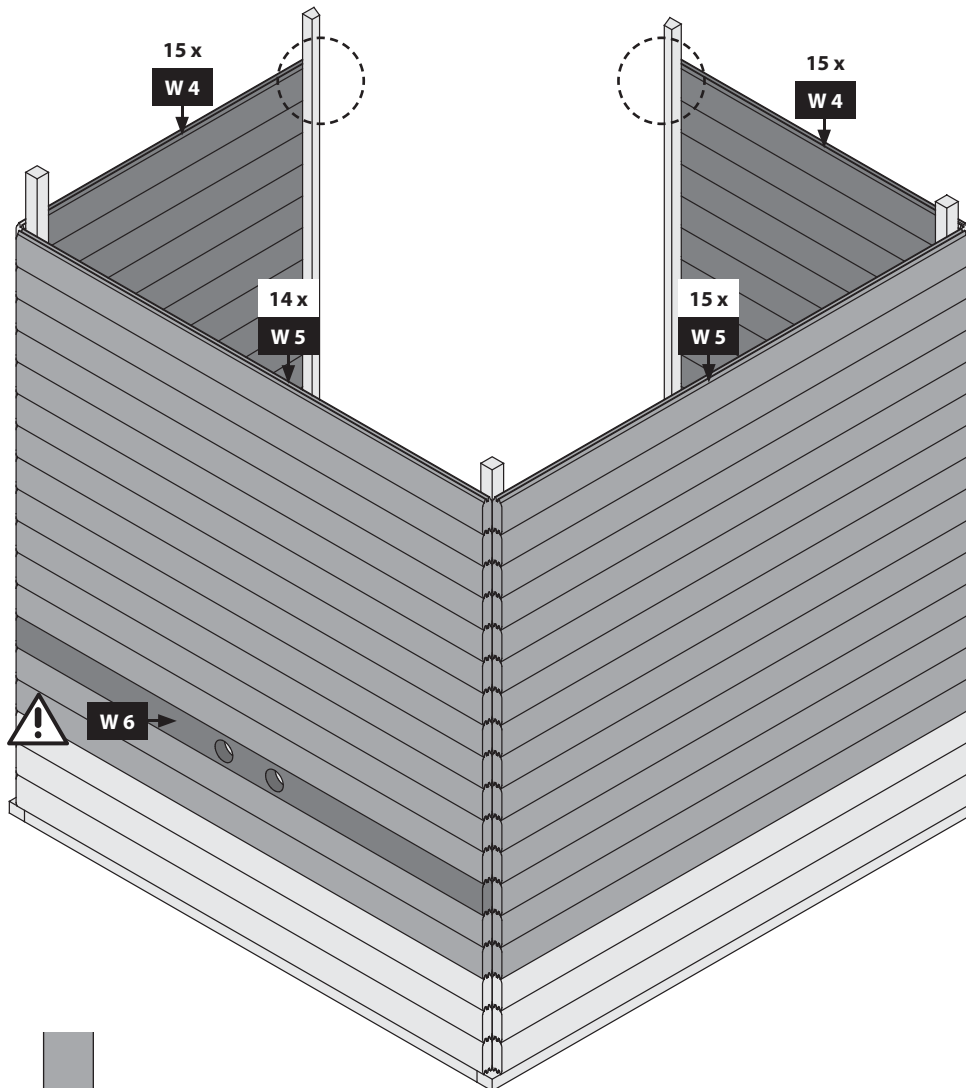
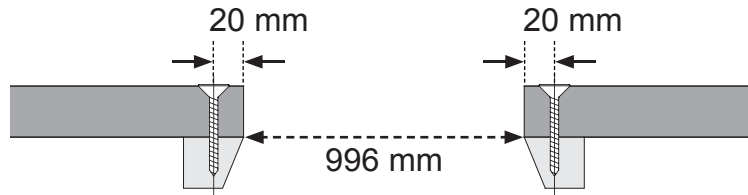

-  Bündig!
-  Flush!
-  Affleurement!
-  I flugt!
-  Gelijk!
-  Aras!
-  Combacia!
-  Stejný !

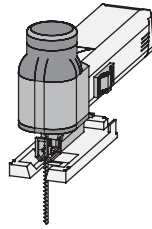

11x

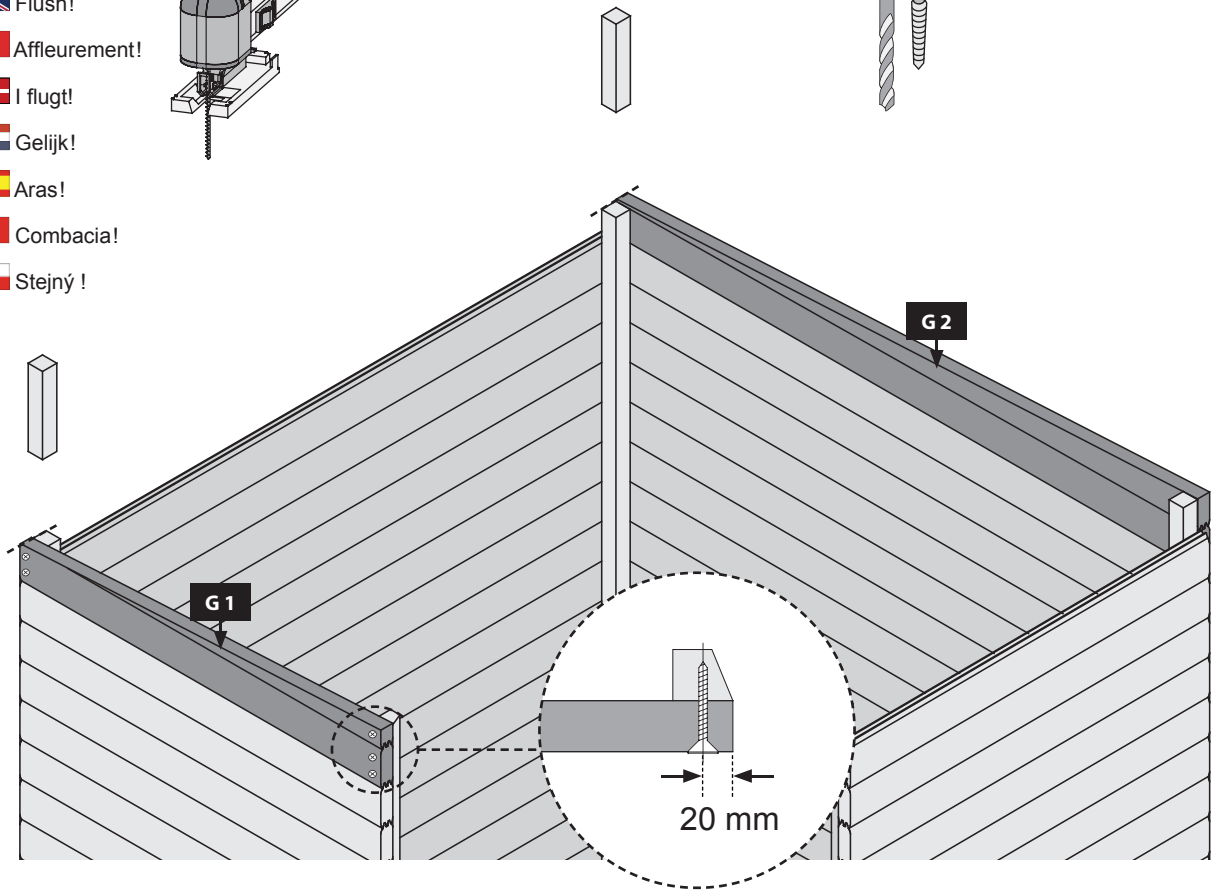
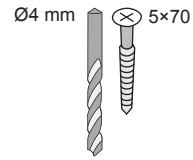

-  Bündig!
-  Flush!
-  Affleurement!
-  I flugt!
-  Gelijk!
-  Aras!
-  Combacia!
-  Stejný !

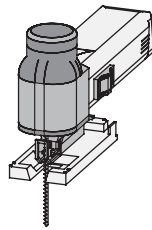

12x

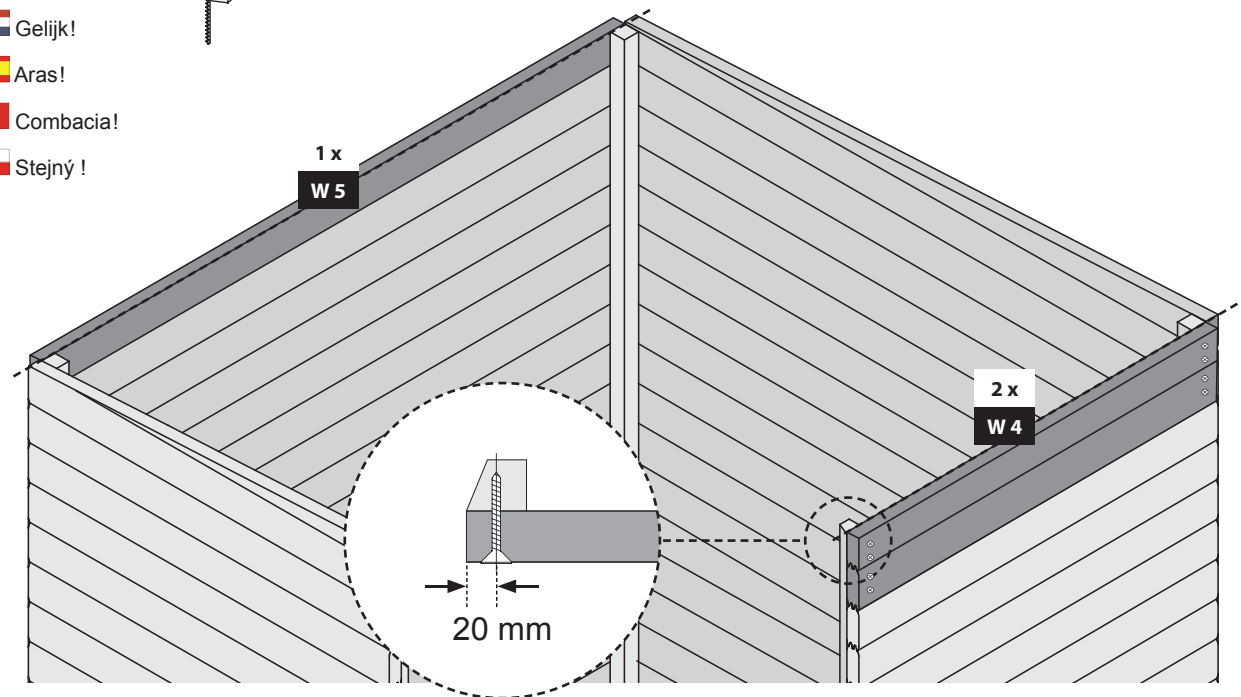
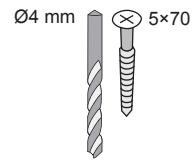

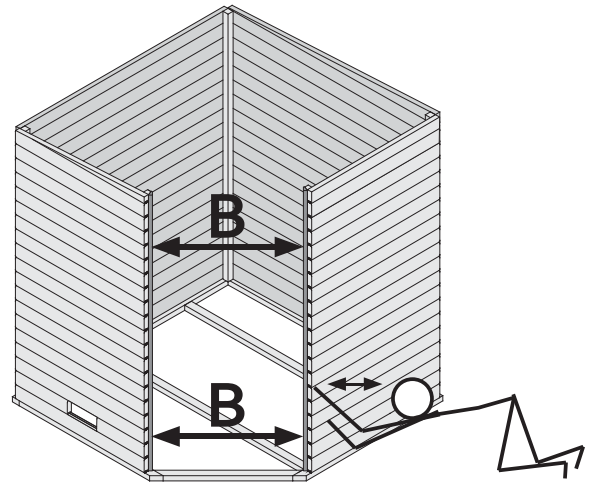
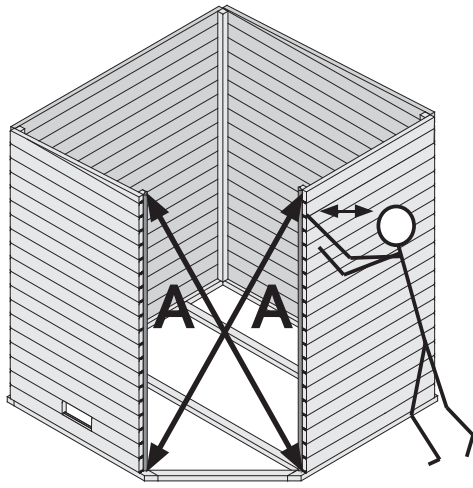

07

-  Leim
-  Glue
-  Colle
-  Lim
-  Lijm
-  Pegamento
-  Colla
-  Klíh

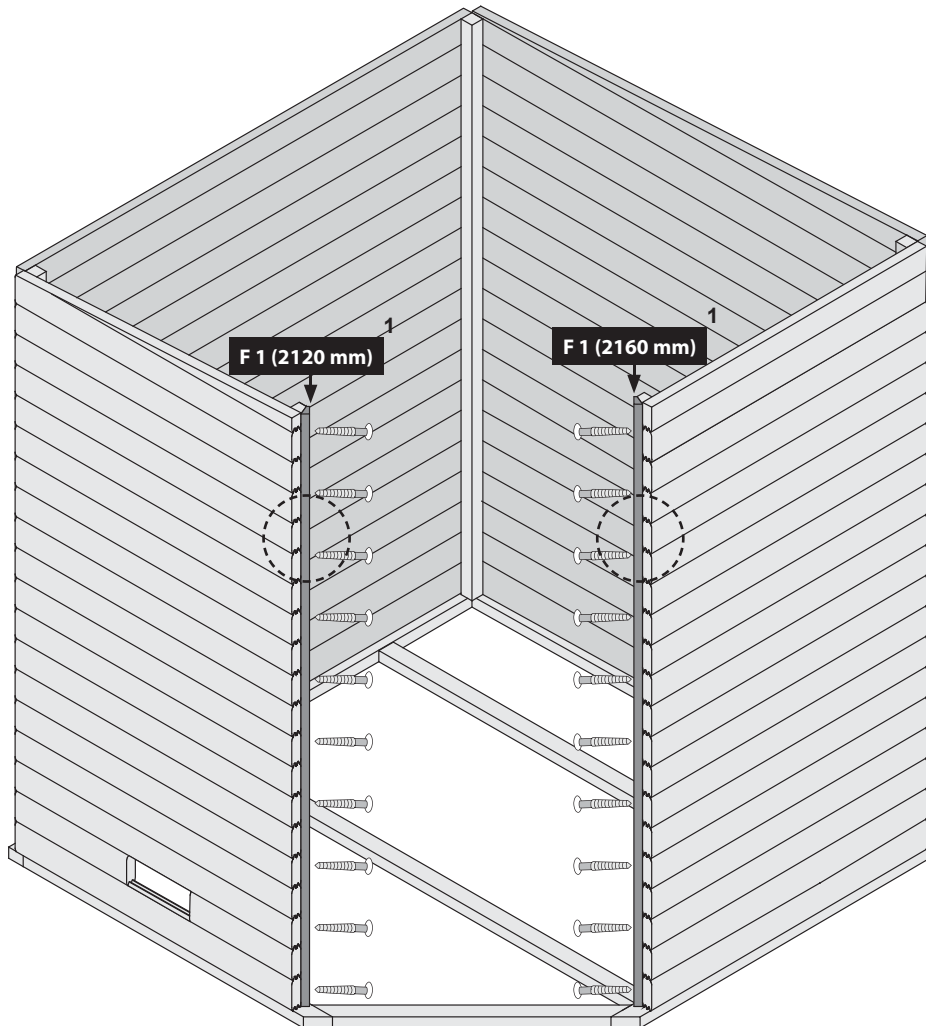
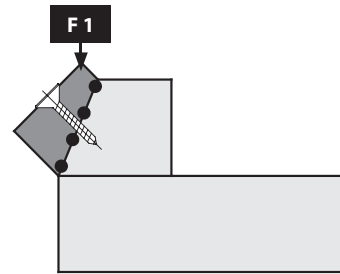
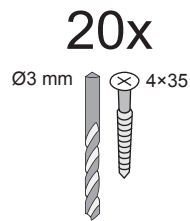
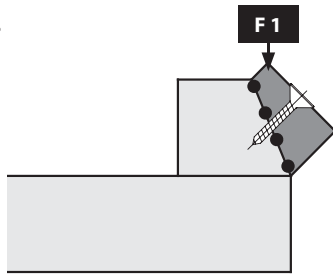

Ø4 mm  
11x  
5×70

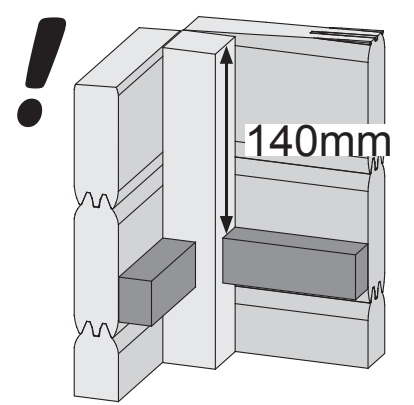
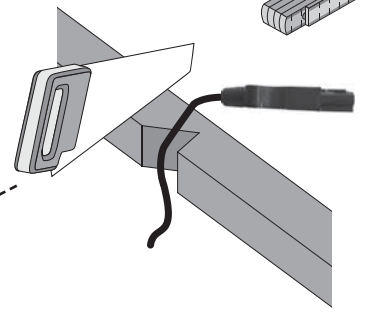
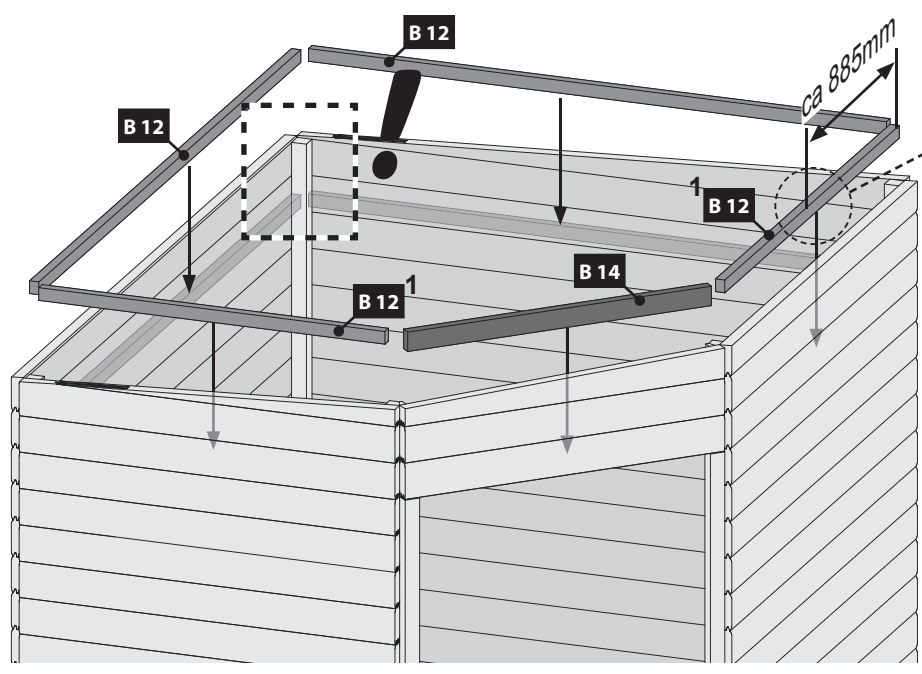
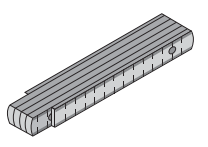
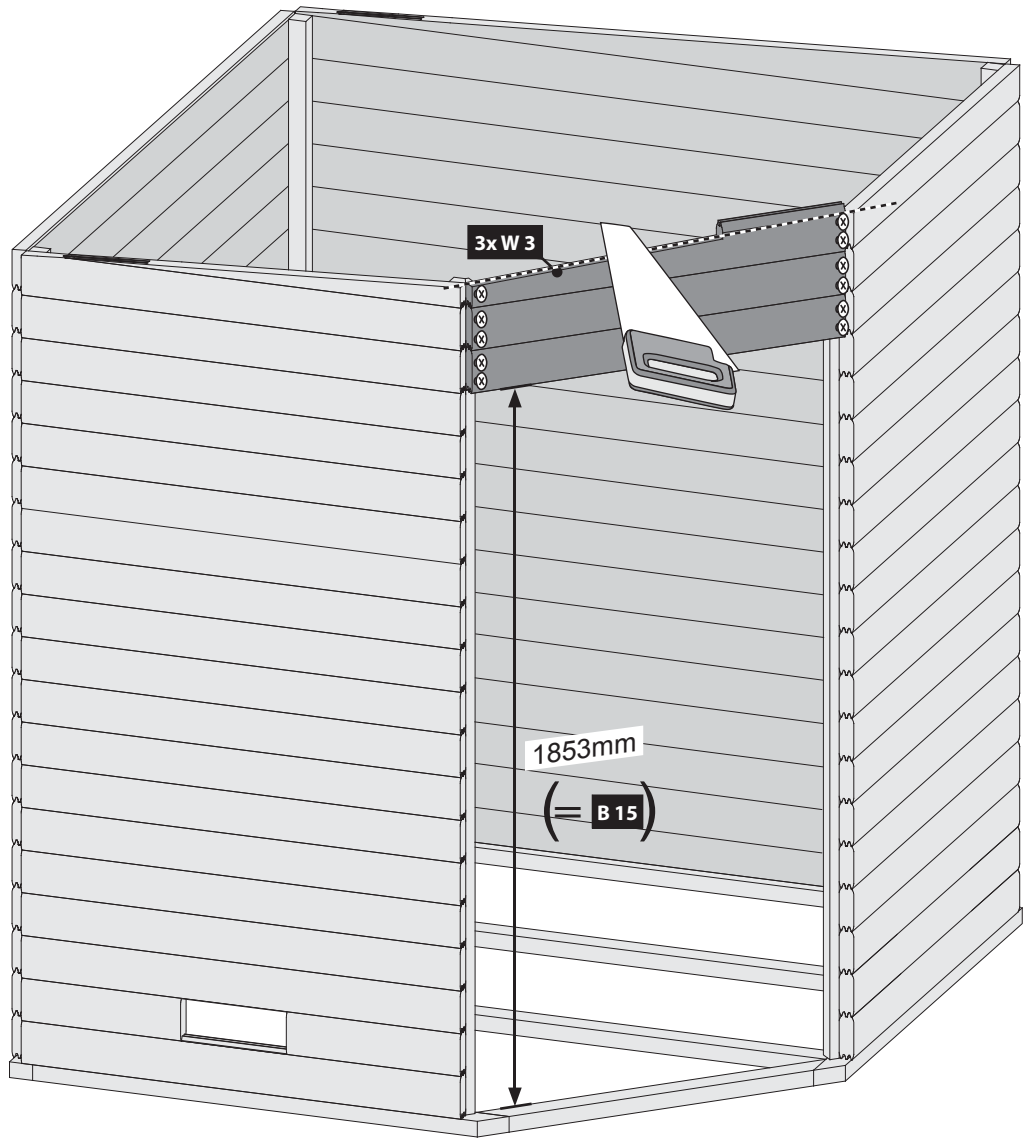



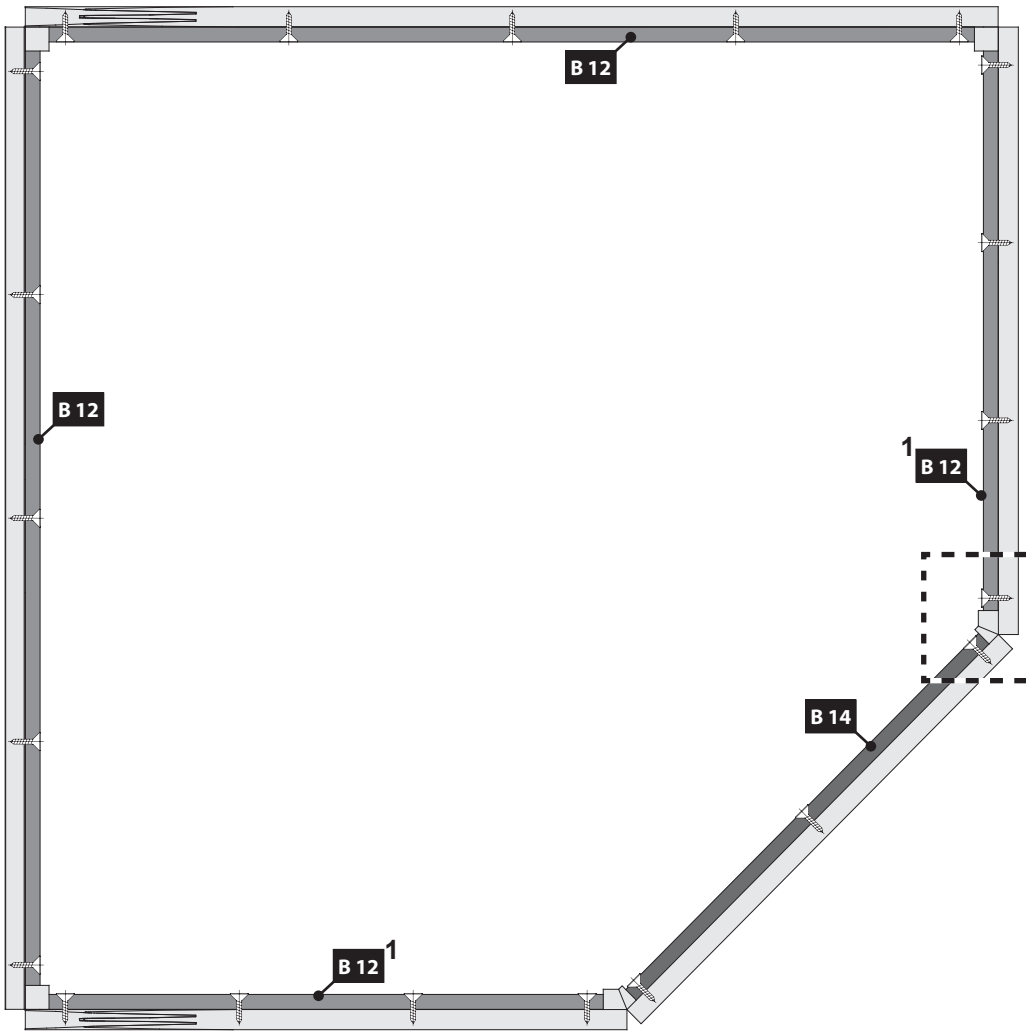

Ø3 mm 4x40

21x

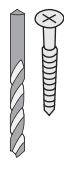

-  Bündig!
-  Flush!
-  Affleurement!
-  Gelijk!
-  I flugt!
-  Aras!
-  Combacia!
-  Stejný !

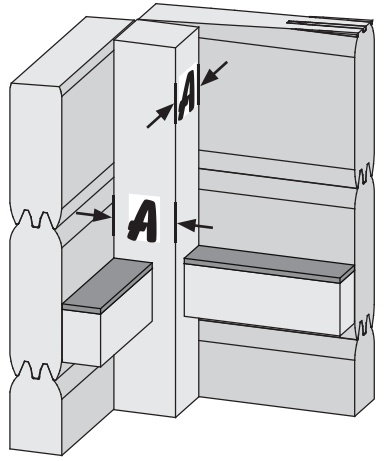
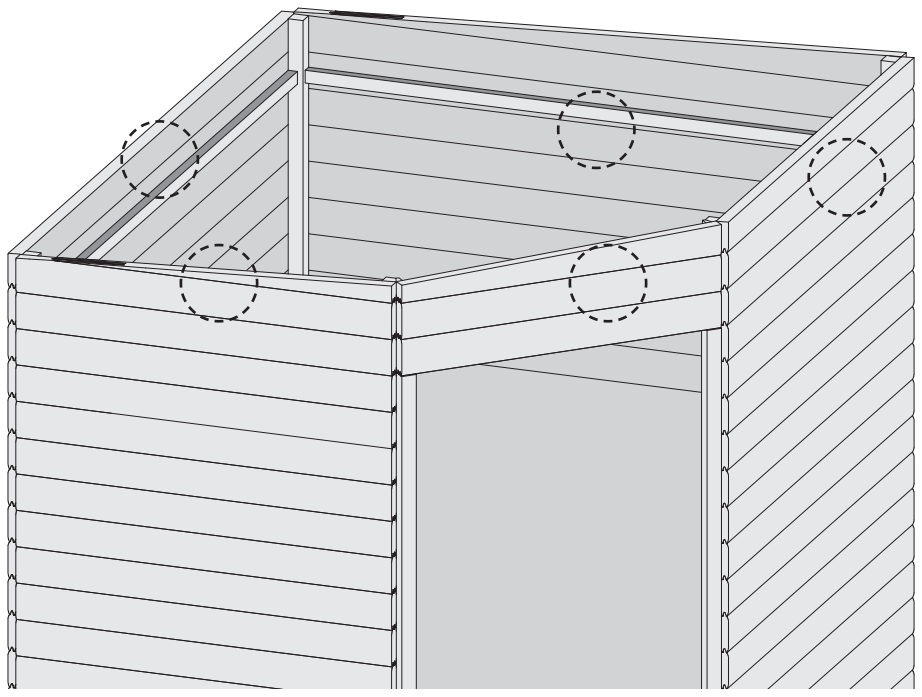
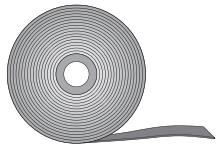
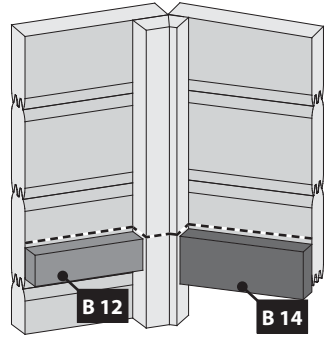

12

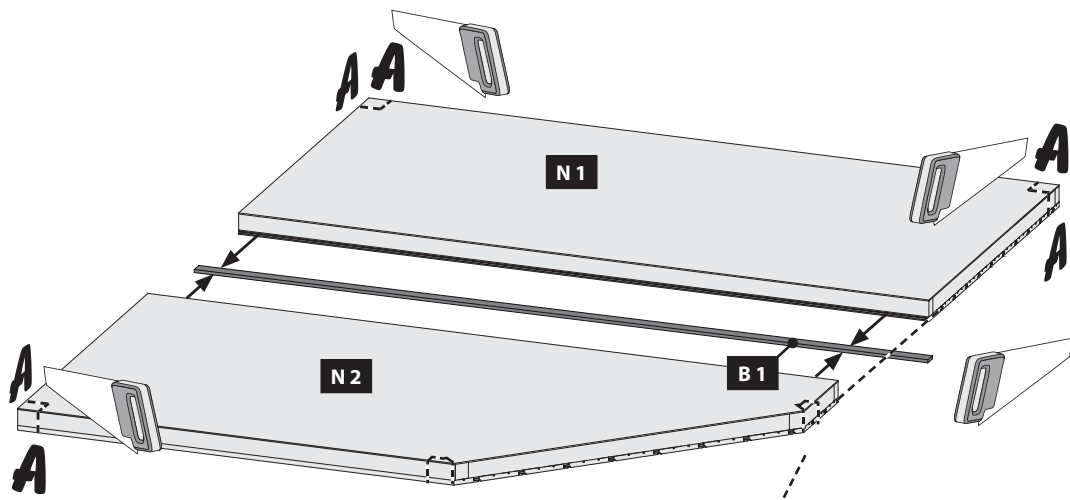

13

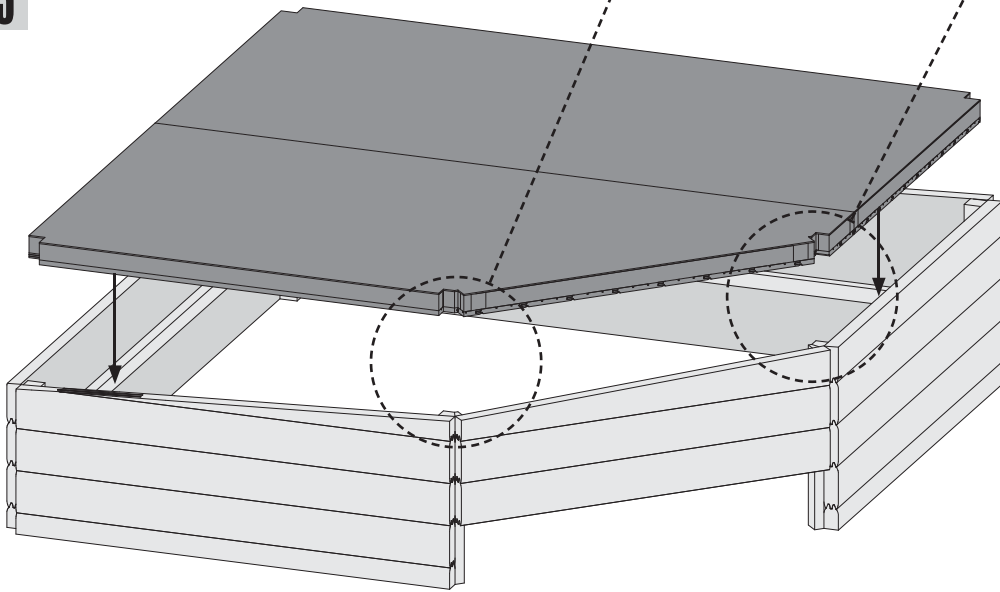

14

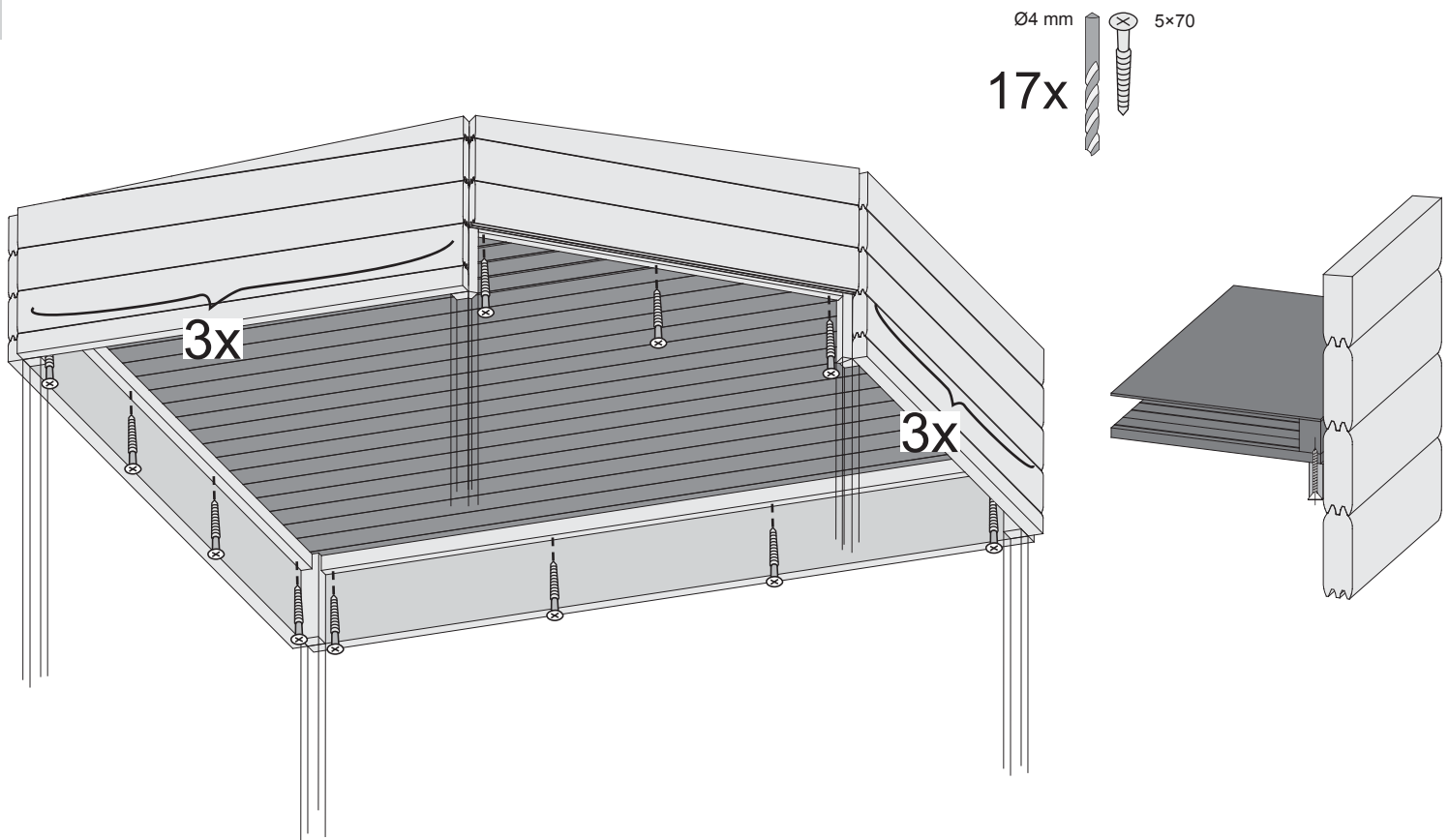

Ø3 mm 4x35



Ø3 mm 4x50

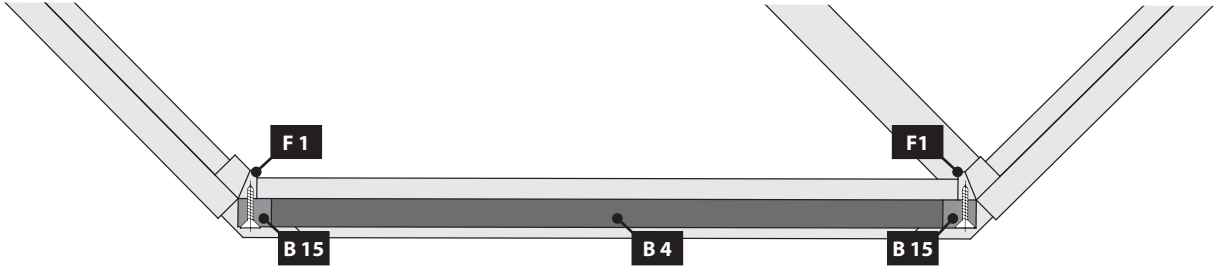

3x



10x





 Breite Seite nach oben  
 Width side up  
 Largeur vers le haut

 Breedte side up  
 Ancho de banda de hasta  
 Larghezza verso l'alto

 Šířka stranou nahoru  
 Bred side op

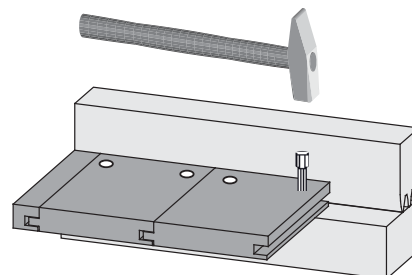
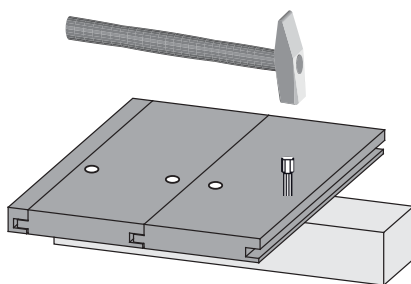
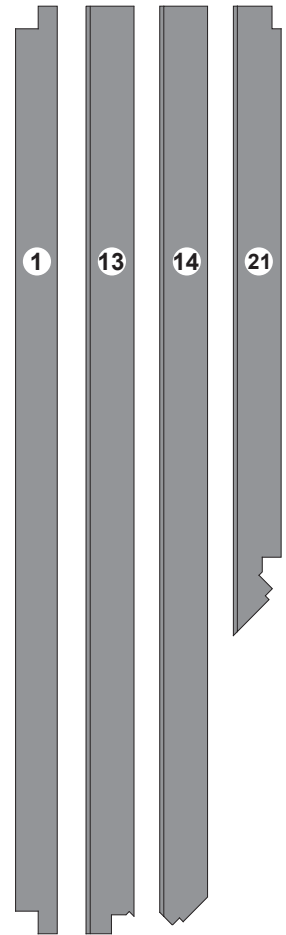
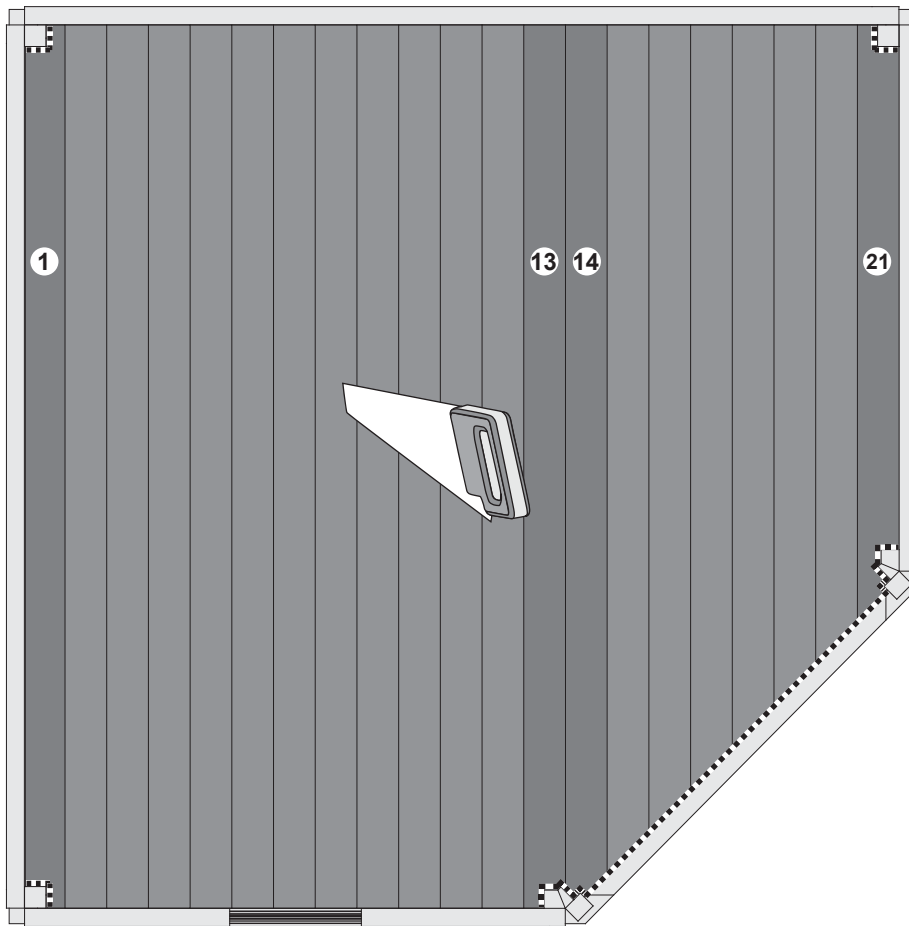
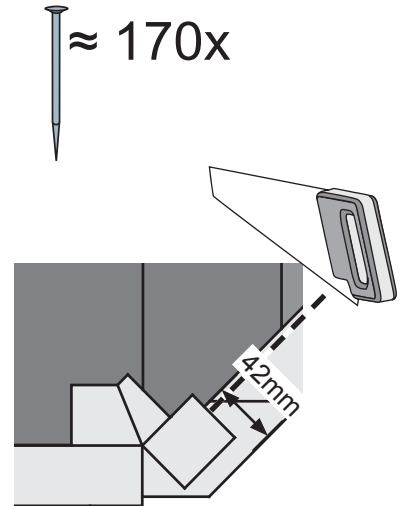
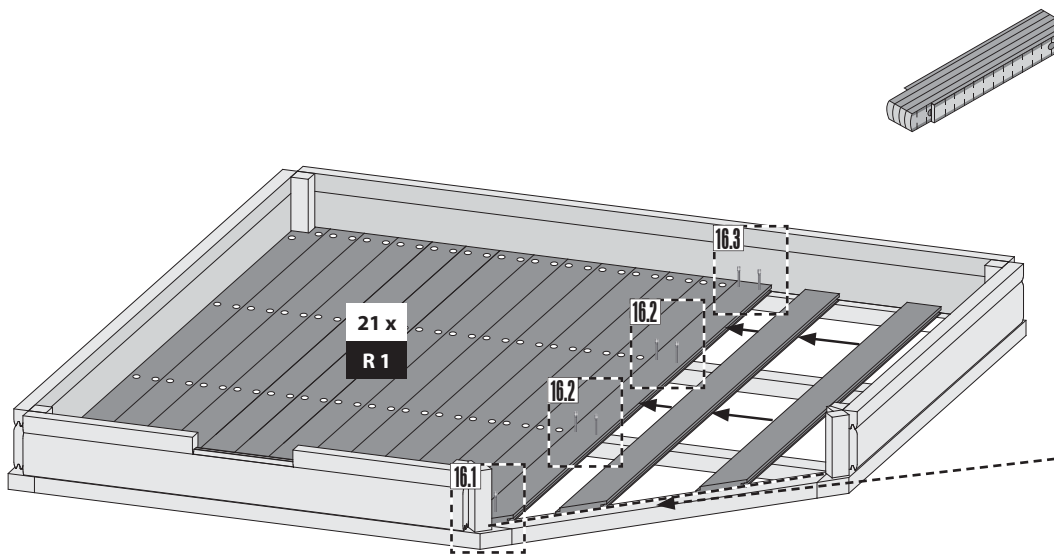

16



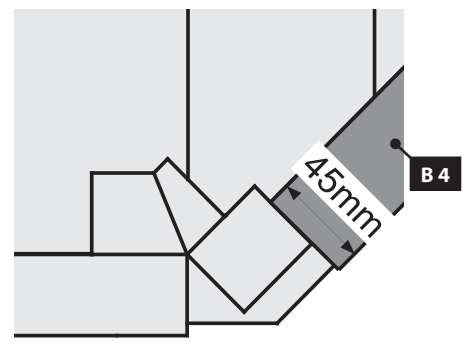
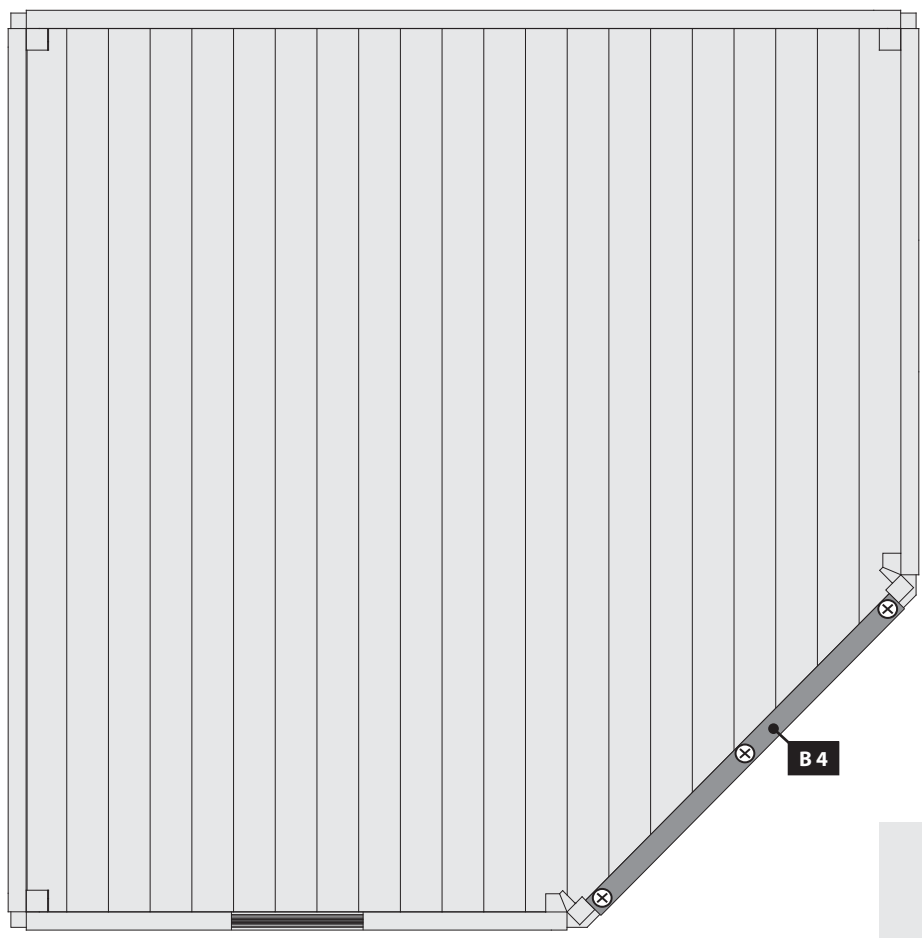

Ø3 mm 4x35  
3x











 Einbau Tür  
 Installation door  
 Porte d'installation

 Installatie deur  
 Installationsdør  
 Puerta de instalación







 Porta di installazione  
 Montážní dveře



-  Anleitung
-  Building instructions
-  Notice de montage
-  Montagehandleiding
-  Montagevejledning
-  Instrucciones de construcción
-  Istruzioni per il montaggio
-  Montážní návod

☎ +49 421 3899 33



-  Anleitung
-  Building instructions
-  Notice de montage
-  Montagehandleiding
-  Montagevejledning
-  Instrucciones de construcción
-  Istruzioni per il montaggio
-  Montážní návod

Karcher Hausbauwerk GmbH • Bismarckstraße 11 • 32717 Bremen • [info.karcher.de](http://info.karcher.de)

 Siehe Türpaket  
 Opmerking Door Package  
 Note Door Package  
 Remarque Package porte  
 Nota Paquete Puerta  
 Nota Door Package  
 Poznámka Door balíček

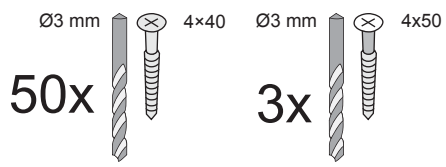

-  Bündig!
-  Flush!
-  Affleurement!
-  Gelijk!
-  I flugt!
-  Aras!
-  Combacia!
-  Stejný !

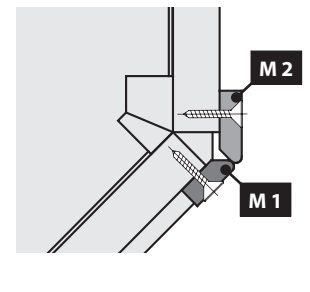
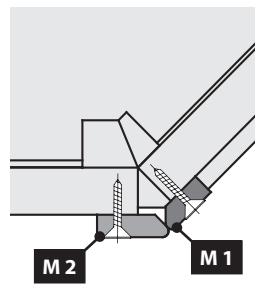
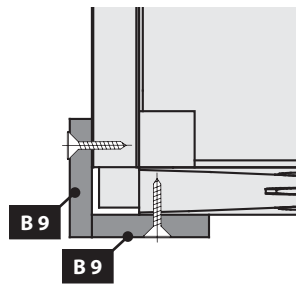
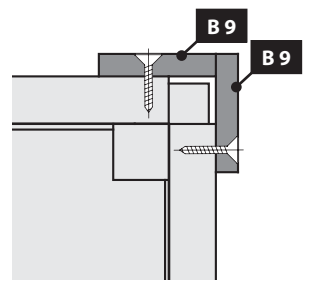
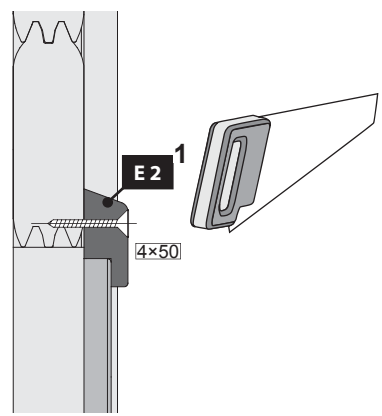
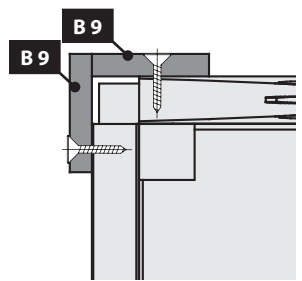
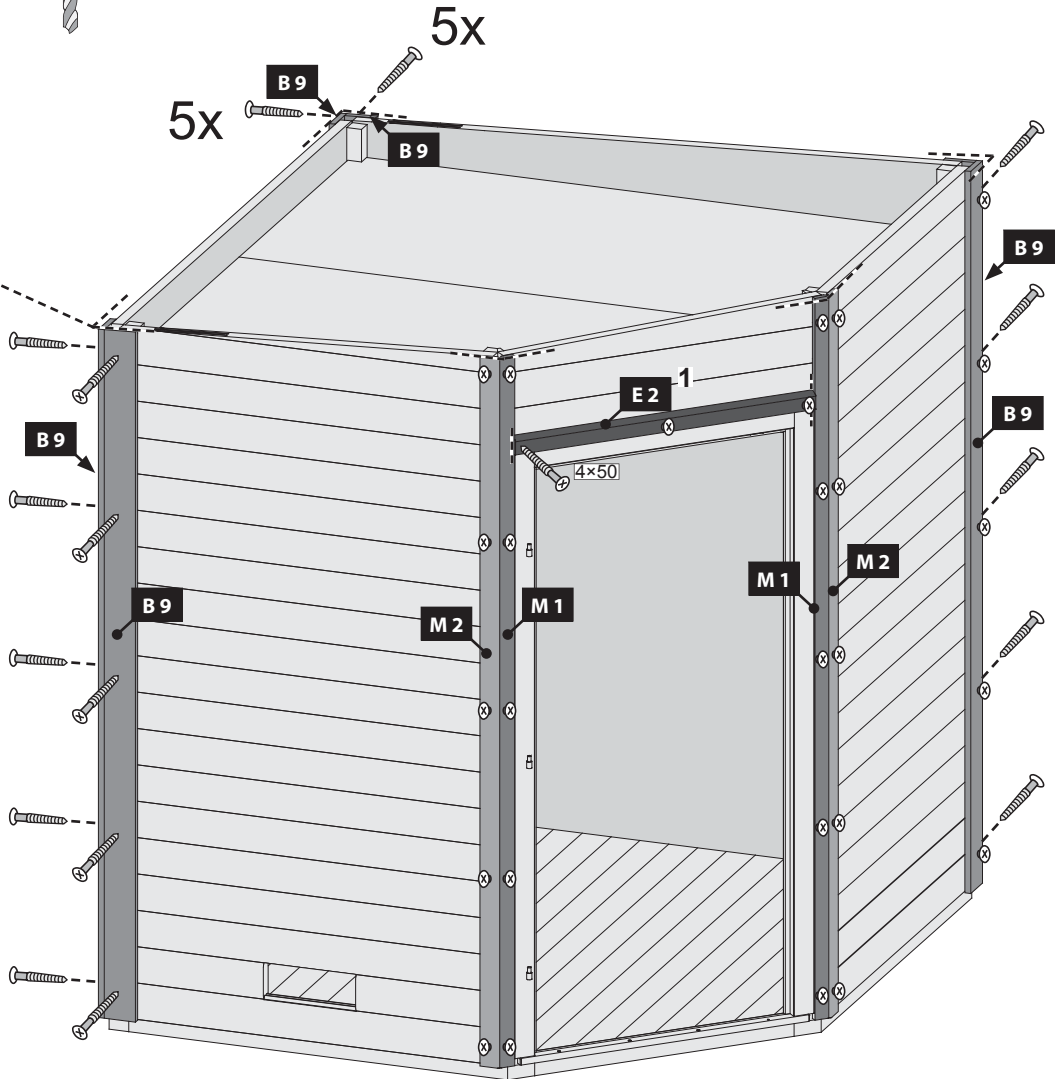
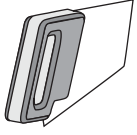

Ø3 mm 4x50  
14x

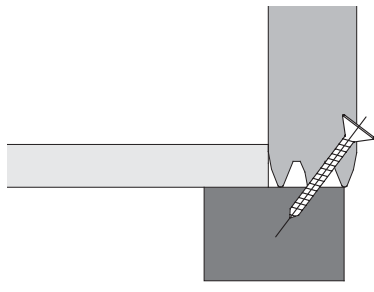
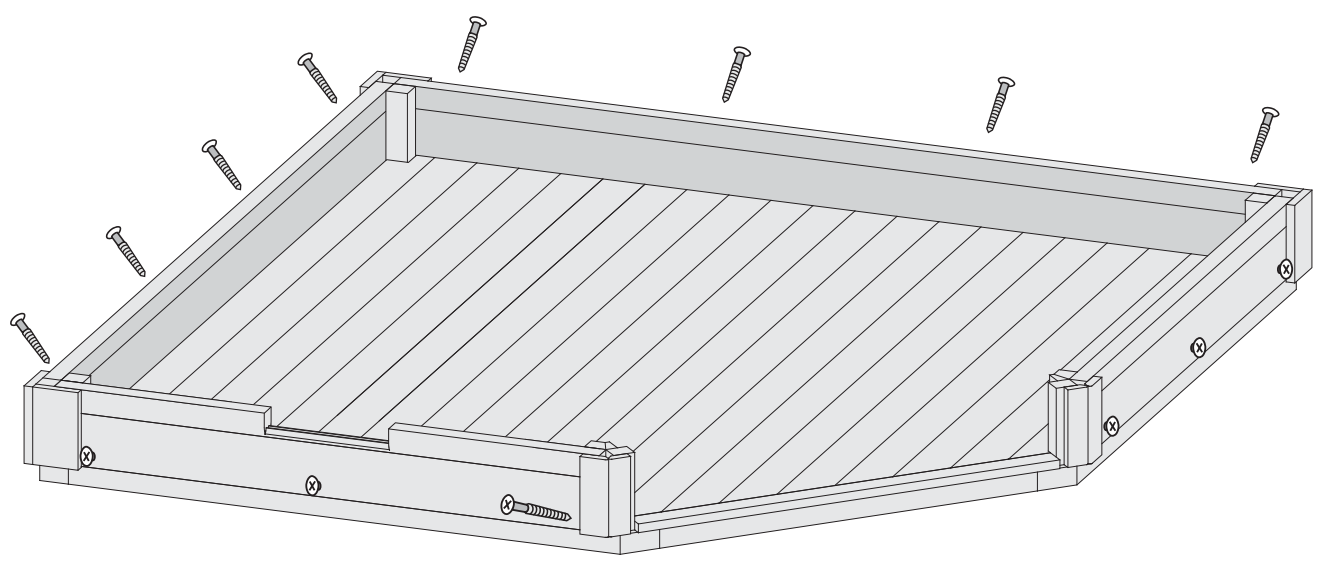

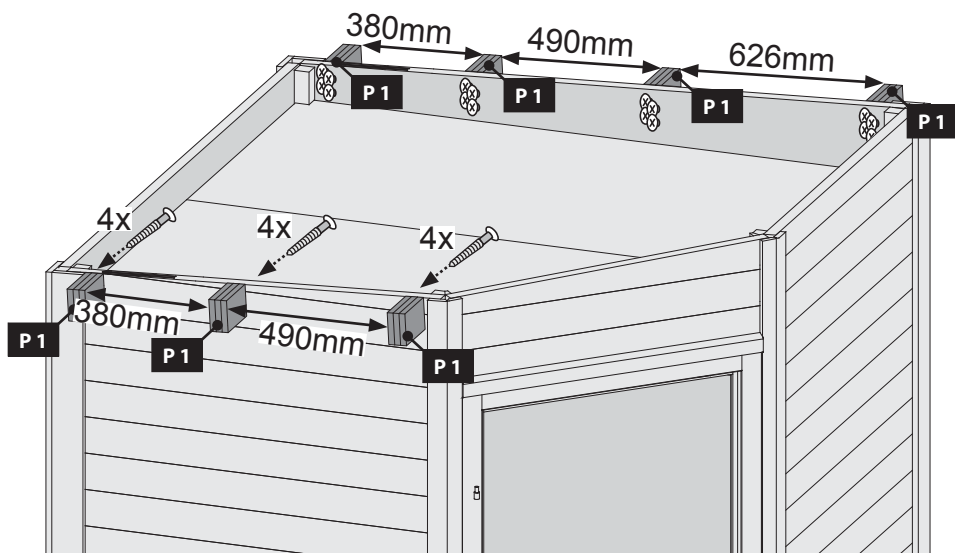

Ø5 mm 6x100

16x

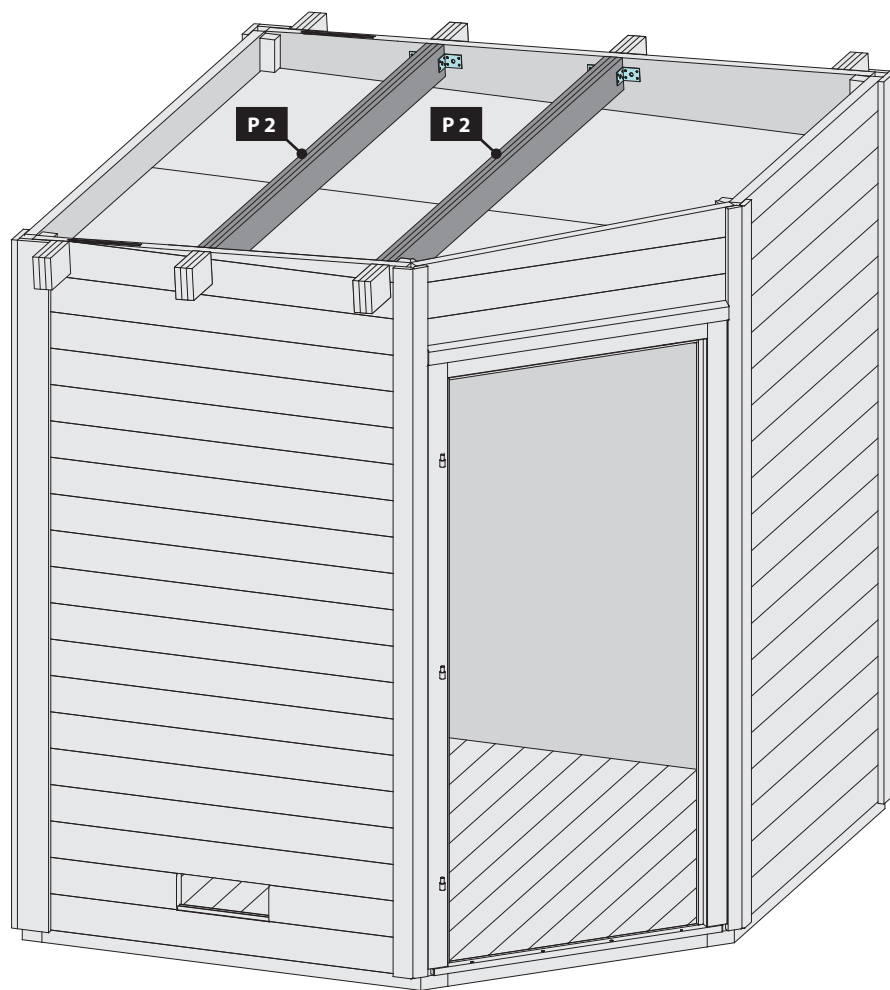
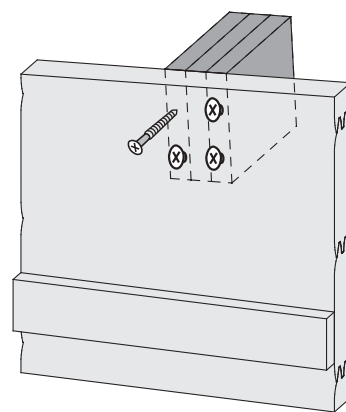

8x

Ø3 mm 4x35

64x



# 22 2x

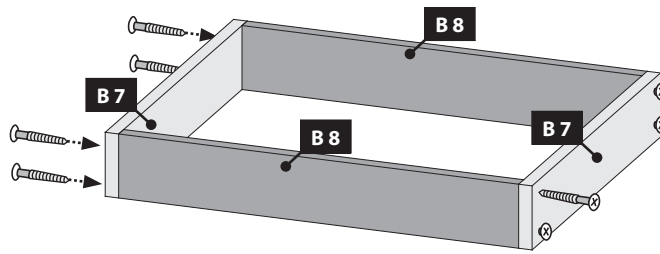





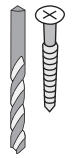

Ø3 mm 4x35

## 16x



# 23 a

-  Nur bei 4,5 / 9 kW-Ofen
-  Seulement 4,5 / 9 kW chauffe
-  Only 4,5 / 9 kW heater
-  Slechts 4,5 / 9 kW heater
-  Sólo calentador de 4,5 / 9 kW
-  Solo riscaldamento 4,5 / 9 kW
-  Pouze topné těleso 4,5 / 9 kW
-  Kun ved 4,5 / 9 kW ovn

Ø3 mm 4x35

## 16x

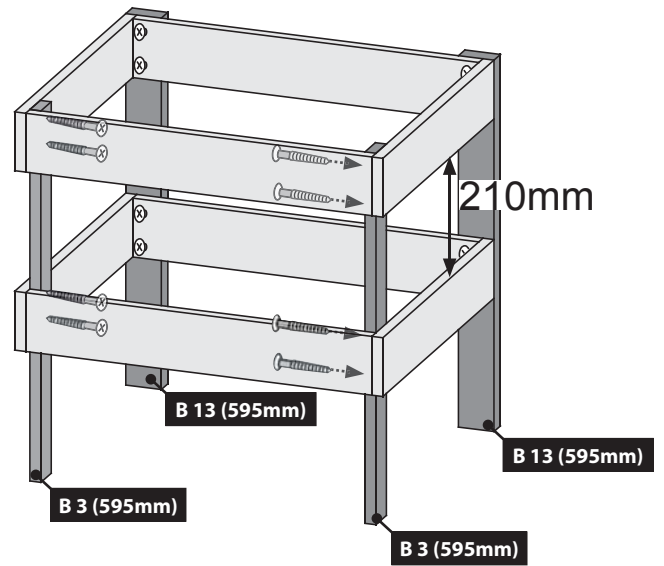
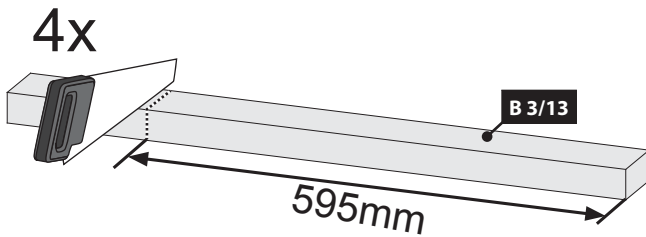
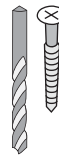

# 23 b

-  Bei allen anderen Öfen
-  Pour tous les autres fours
-  For all other furnaces
-  Voor alle andere ovens
-  Para todos los otros hornos
-  Per tutti gli altri tipi di forni
-  U všech ostatních pecích
-  Til alle andre ovne

Ø3 mm 4x35

## 16x

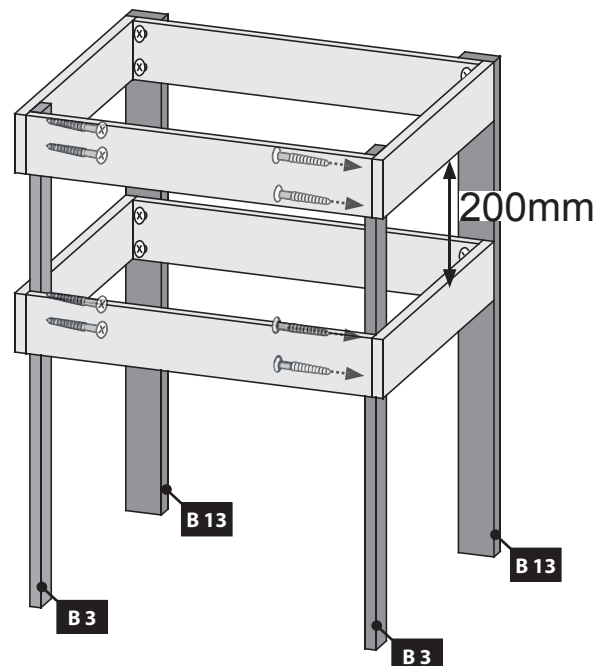
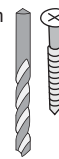

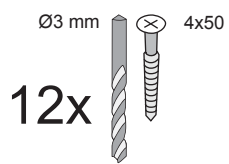
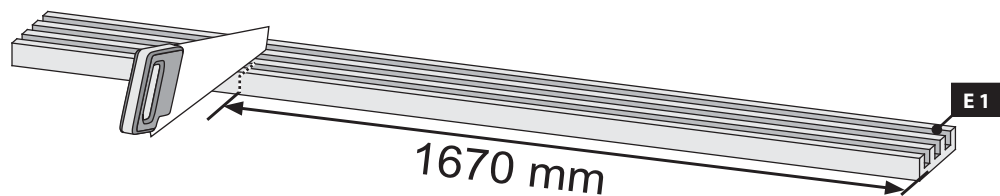

1.  Ø15mm
- 2.

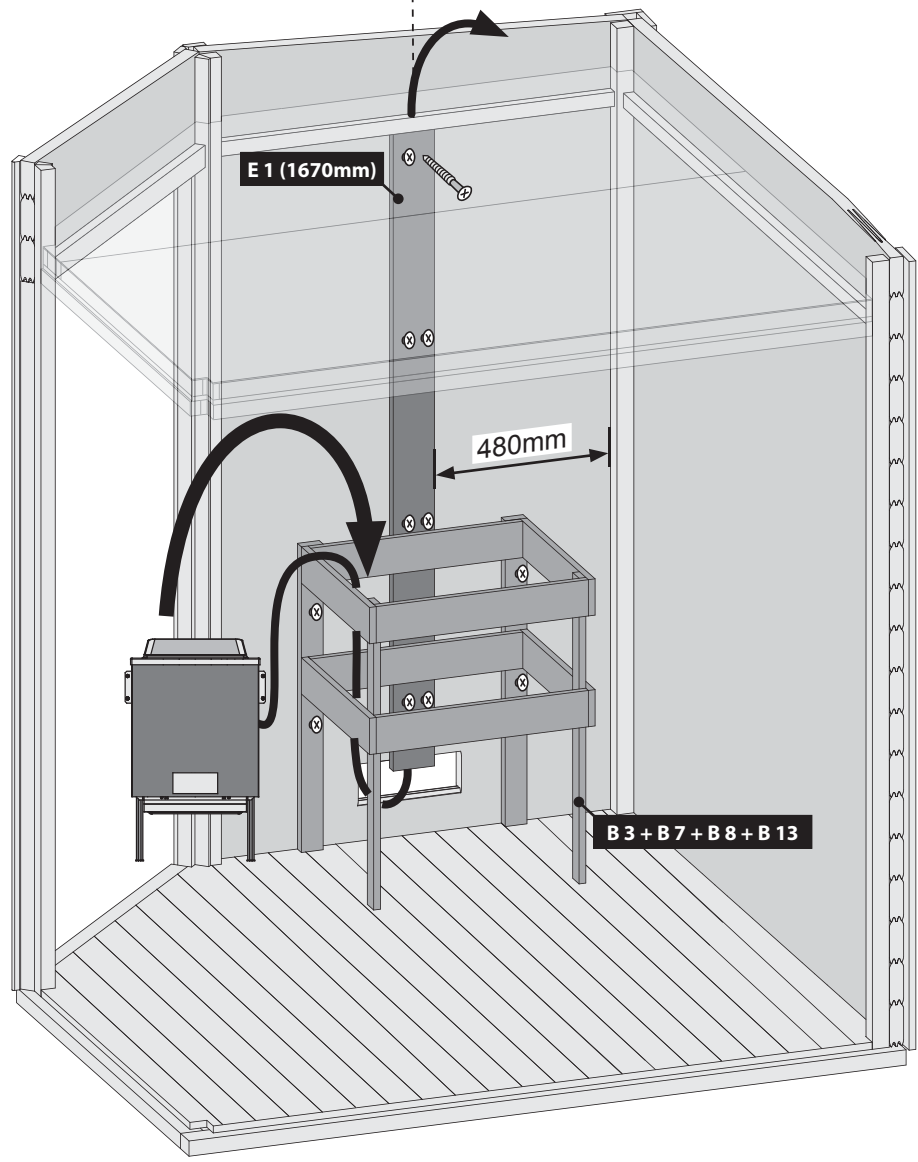

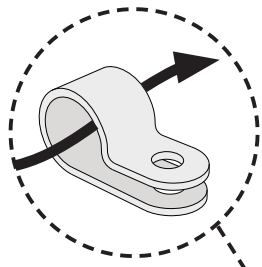

Ø2 mm 3x16  
1x

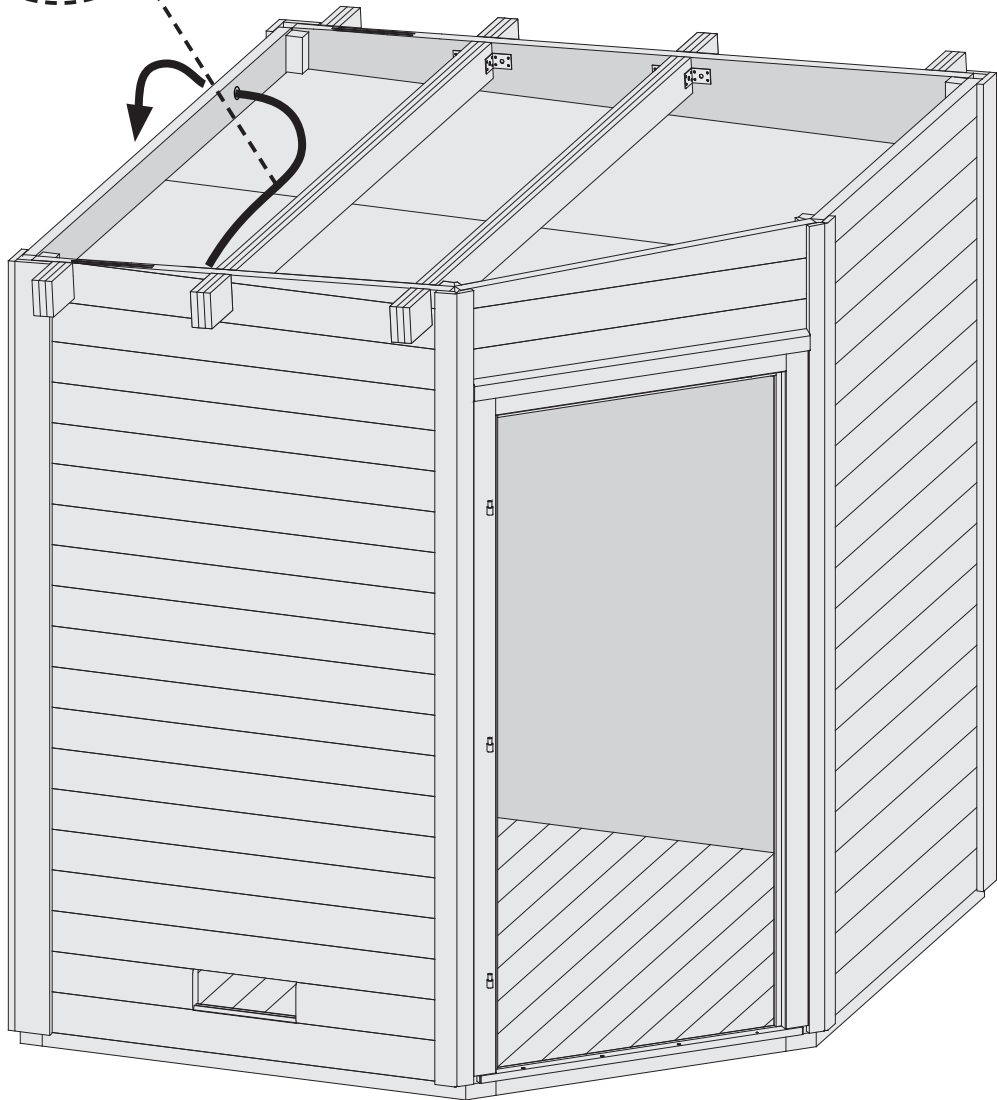
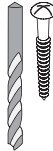

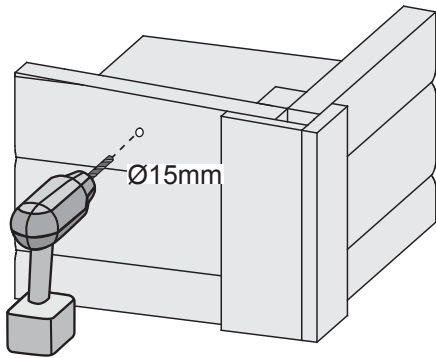

1.



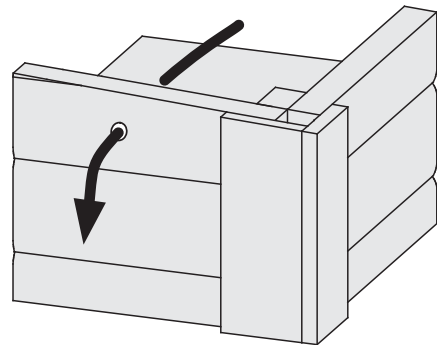



2.





-  Schmale Seite nach oben
-  Narrow side up
-  Smal side op

-  Narrow vers le haut
-  Smalle kant naar boven
-  Estrecha hacia arriba
-  Stretta verso l'alto
-  Úzká stranou nahoru

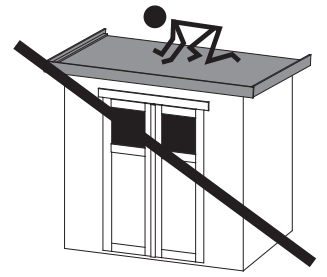
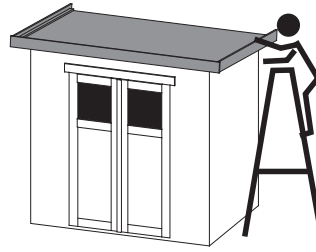

27

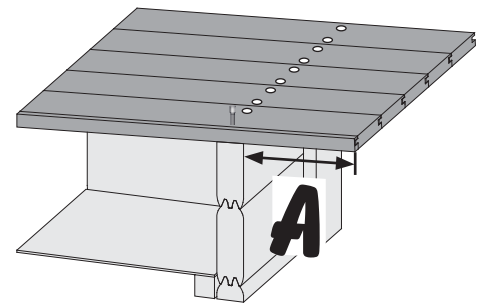
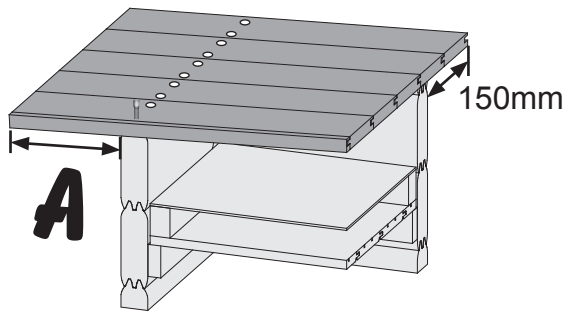
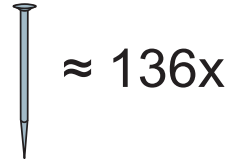
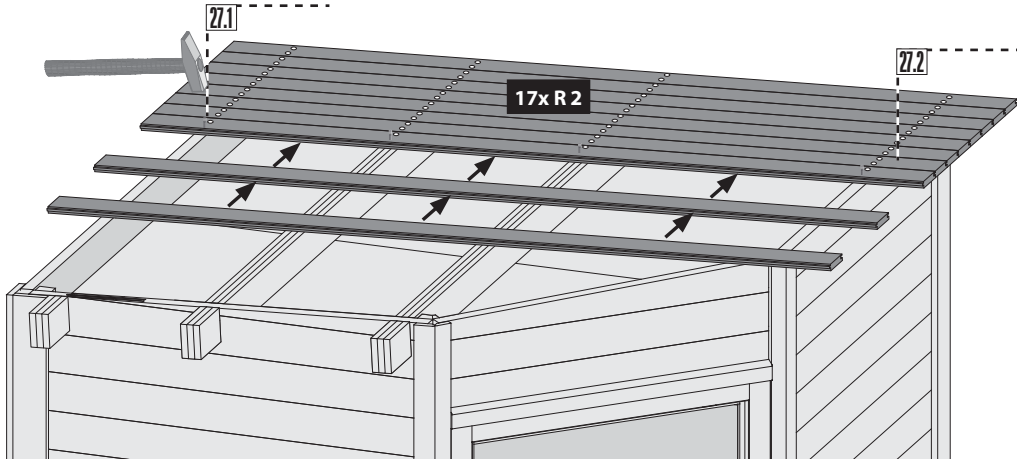

28

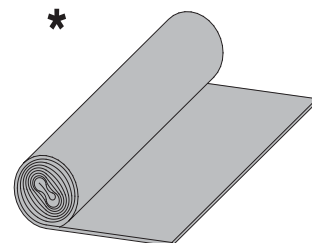
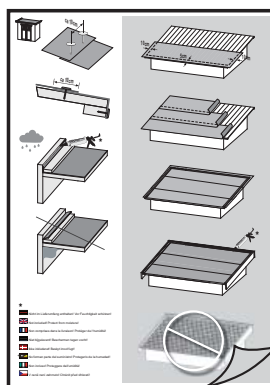
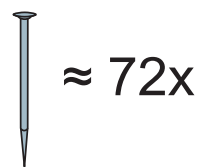
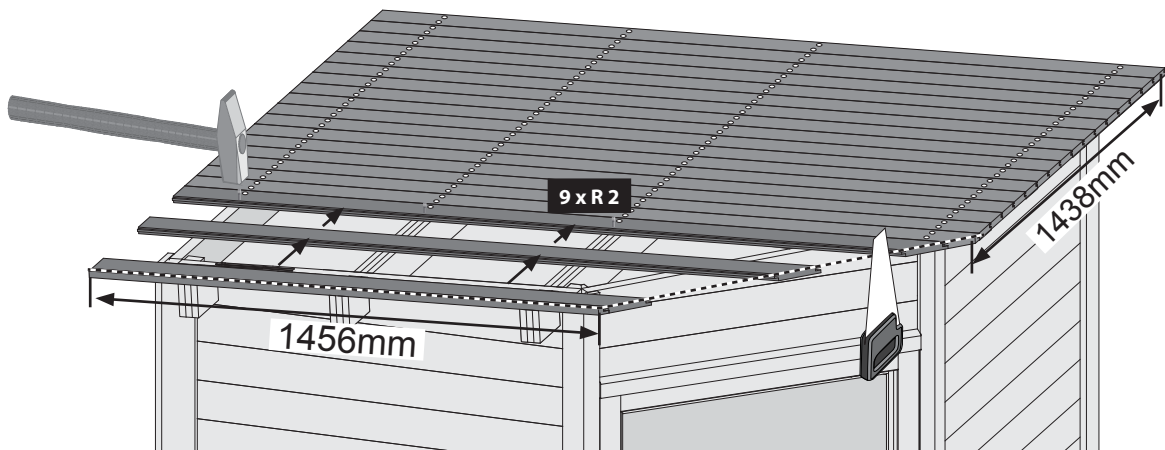

 Montage Bitumendachbelag

 Montage de toiture en bitume

 Montage bitumen underpap

 Copertura bituminosa

 Roofing felt installation

 Montage dakvilt

 Montaje de tela asfáltica

 montáž střešní krytiny

 Achtung, dies ist nur ein Verlegebeispiel!

Die Anzahl der Bahnen richtet sich nach Ihrer Hausgröße. Verbindungen zwischen den Bahnen sind mit einer Überlappung von ca. 10 cm auszuführen. Das Dach ist nicht begehrbar. Die Konstruktion ist für eine Gesamtbelastung (Schnee, Wind) und nicht für eine Punktbelastung ausgelegt. Zur Montage empfehlen wir eine bauseitige Abstützung des Daches von unten. Die Abdichtung der Dachflächen zu angrenzenden Bauteilen mit Bitumendichtmasse ist bauseits zu lösen! Sofern es sich um ein Haus mit Satteldach handelt, sollte bei der Verwendung von Dachschindeln keine Voreindeckung mit Dachpappe vorgenommen werden. Hier sollte lediglich an den beiden Traufseiten ein 20 cm breiter Streifen mit Überstand angebracht werden. Bei Häusern mit einem Tonnendach, verlegen Sie bitte einen Bitumenbelag unter die Schindeln. Bei einem Flachdach ist die Verlegung von Dachschindeln nicht möglich!

 Note! This description is only an example!

The number of bitumen strips to be used depends on your actual house size. When joining rolls of roofing felt end to end, the overlap must be approximately 10cm. The roof is not safe to walk on. The roof is designed for a total load (snow, wind) and not for a point load. We recommend you to always support the roof from below during installation. The sealing of the roof surfaces to adjacent components with bitumen sealant has to be effected by the customer! If it is a saddle-roofed house, do not use roofing tiles for roofing. In this case, a 20 cm wide strip of bitumen with overhang should be installed on both sides of the eaves. For houses with a tonne roof, please install a bitumen roofing under the shingles. In the case of a flat roof the laying of roof shingles is not possible!

 Attention, il s'agit uniquement d'un exemple de pose!

Le nombre de bandes de bitume utilisés dépend de la dimension de la maison. La jointure des bandes de bitume doit être réalisée avec un chevauchement de 10 cm. Ne pas marcher sur le toit! La construction est appropriée pour une charge totale (neige, vent) et ne pas une charge ponctuelle sur un point précis. Lors du montage, il vous est recommandé de soutenir le toit d'en dessous. L'imperméabilisation des surfaces de toit aux composants adjacents avec un mastic de bitume doit être effectuée par le client! Lorsque vous utilisez des bardeaux pour couvrir une maison avec un toit à deux versants, ne jamais utiliser toiture en bitume ci-dessous. Pour les maisons avec toit en berceau, poser du carton bitumé sous les bardeaux. Pour les maisons de toit plat de la pose de bardeaux de toiture n'est pas possible!

 Let op, dit is slechts een montagevoorbeeld!

Het aantal dakviltbanen is afhankelijk van de grootte van uw huis. Verbindingen tussen de stroken uit te voeren met een overlapping van ongeveer 10 cm. Het dak is niet beloopbaar. De constructie is ontworpen voor een totaalbelasting (sneeuw, wind) en niet voor een puntbelasting. Voor de montage adviseren we te voorzien in een zelf aan te brengen steun voor het dak van onderen. De afdichting van de dakoppervlakken van aangrenzende componenten met bitumen afdichtmiddel op te lossen door de klant! Als het gaat om huis met een zadeldak, mag geen Voreindeckung worden gemaakt met dakleer in het gebruik van dakbedekking gordelroos. Hier, moet alleen de twee dakrand zijden een 20cm brede strook dakleer aan te leggen met een overstek. Voor huizen met een dak vat installeer dan een dakleer onder de gordelroos. Met een plat dak leggen shingles is niet mogelijk!

 Bemærk, dette er kun et monteringsseksempel!

Antallet af påkrævede ruller af tagbeklædning afhænger af husets faktiske størrelse. Ved sammenføjning af tagdækning ruller ende til ende, skal overlappningen være 10 cm. Når du kun bruger 4 baner af tagpap, skal du altid dække den vandrette kantbjælke med rullerne fra begge sider. Taget er ikke sikkert at gå på. Taget er designet til en total belastning (sne, vind) og ikke for en punktbelastning. Vi anbefaler at du altid støtter taget nedenunder under installationen. Tætningen af tagfladerne til vindbrættet i forenderne skal løses af kunden! Når du bruger tagshingles til at inddække et hus med gavtag, skal du altid bruge underpap tagbeklædningen. Her lægges et 20 cm bredt bånd af tagbeklædning med overlæg på begge sider. Monter altid underpap tagbeklædningen under tagshingles til huse med et buet tag. Ved fladt tag kan tagshingles ikke anvendes!

 Cuidado, éste es sólo un ejemplo de instalación!

La cantidad de tiras de tela asfáltica depende del tamaño de su caseta. Las juntas de tela en una tira se realizan solapando la tela asfáltica 10 cm. El techo no es transitable. La construcción está preparada para cargas totales (nieve, viento) y no para cargas puntuales. Para el montaje se recomienda apuntalar el techo por debajo. A menos que haya una casa de techo a dos aguas, sin Voreindeckung debe hacerse con tela asfáltica en el uso de tejas para techos. En este caso, sólo los dos aleros partes deben ser de una amplia franja de 20 cm de tela asfáltica que deben colocarse con un voladizo. Para las casas con el techo abovedado y por favor, instale un techo sintió debajo de las tejas. Con un techo plano por el que las tejas no es posible!

 Attenzione, questo è solo un esempio di posa!

La quantità dei rulli di cartone catramato dipende dalle dimensioni della casa. Il concatenamento tra i nastri deve essere effettuata con una sovrapposizione di circa 10 cm. Non salire sul tetto. La costruzione è progettata per un carico diffuso (neve, vento) e non per una concentrazione puntuale del peso. Per il montaggio si consiglia un supporto del tetto con una costruzione posta sotto di esso. Se si dispone di una casa con un tetto a capanna e si desidera utilizzare tegole di copertura, deve essere posato senza fogli di bitume. Qui, un largo 20 cm striscia di bitume deve essere montato esclusivamente ad entrambi i lati della grondaia sporgente 20 cm. Per le case con fogli di bitume per tetti a botte sotto il fuoco di Sant'Antonio da installare. Si prega di non utilizzare il fuoco di Sant'Antonio Dackdeckung con un tetto piatto.

 Pozor, toto je jen příklad, kterým!

Počet Dachpappbahnen závisí na velikosti domu. Spojení mezi asfaltem pásu má být provedena s přesahem asi 10 cm. Při použití pouze čtyř běhy ne Firstbahn použití, boční panely s ležel přes hřeben. Střecha není přístupný. Konstrukce je (sníh, vítr) a není určen pro bodové zatížení na celkové zatížení. Pro montáž doporučujeme znovu podporu na místě střechy zespodu. Utěsnění střešních oblastí do podhledů na čelních plochách je na místě řešit! Máte-li dům se sedlovou střechou, je třeba žádné Asfaltové pásy umístěny pod šindele. Zde je 20 cm široký pás střešní plst' je pouze na obou stranách okapového se supernatantem odloženou. Pro rodinné domy s valenou střechou prosím ležel lepenkový pod šindelem. Pro ploché střechy domů pokládka střešních šindelů není možné!

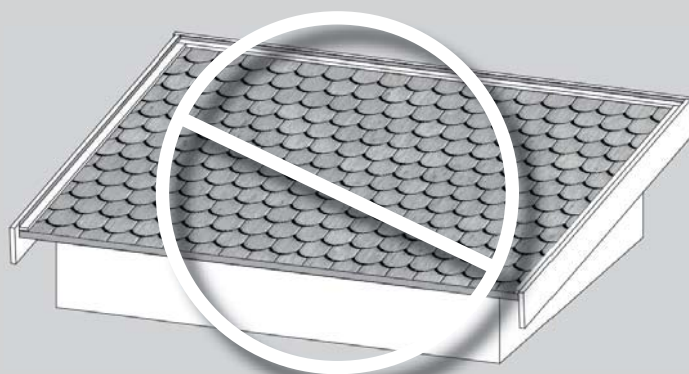
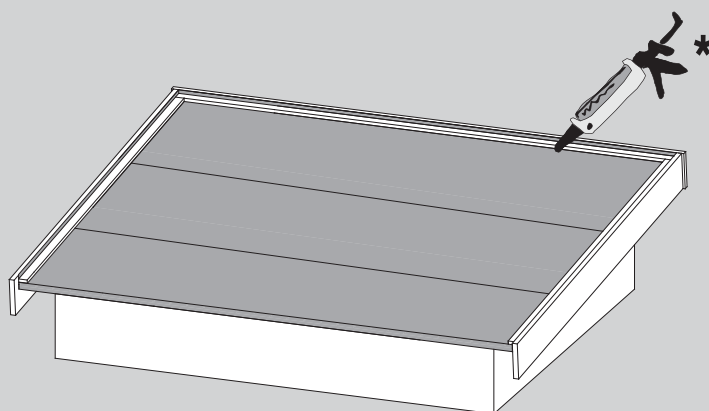
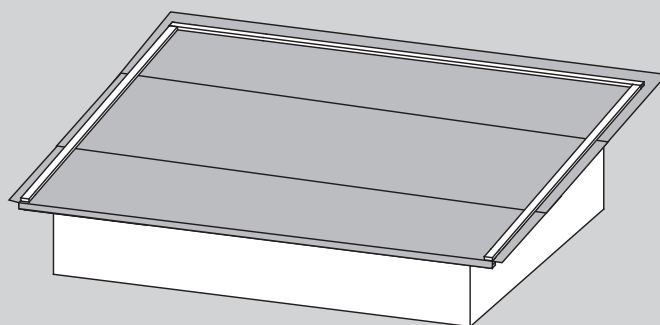
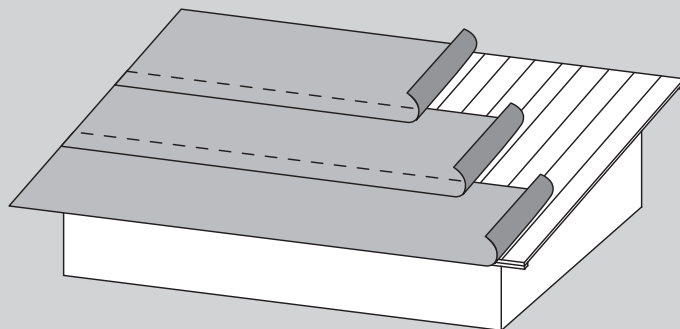
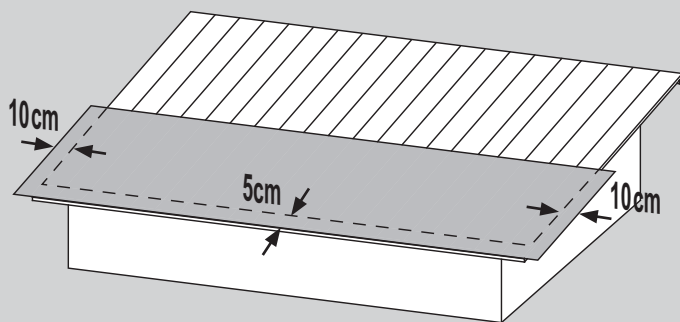
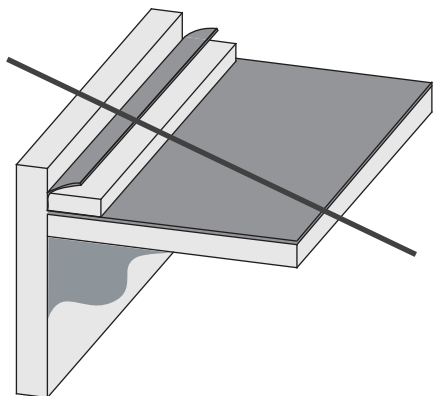
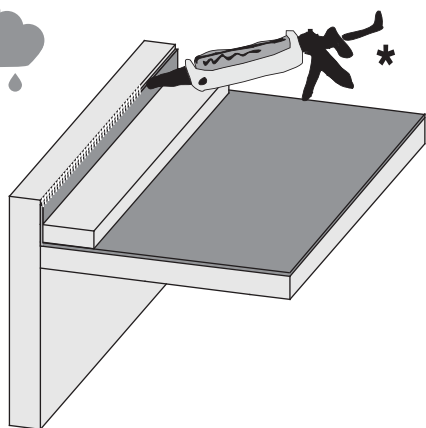
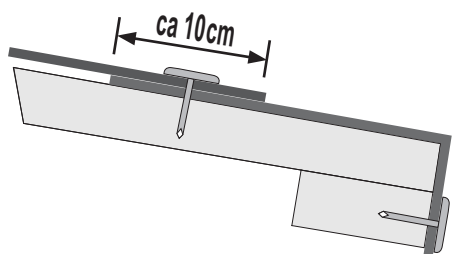
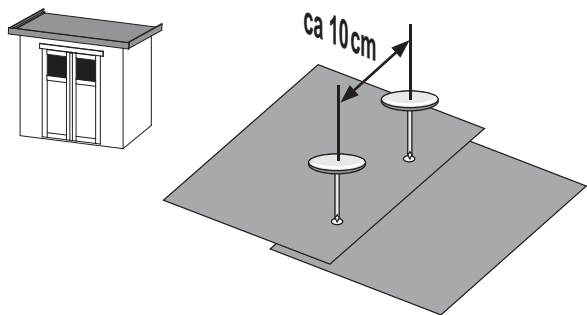



\*

 Nicht im Lieferumfang enthalten! Vor Feuchtigkeit schützen!

 Not included! Protect from moisture!

 Non comprises dans la livraison! Protéger de l'humidité!

 Niet bijgeleverd! Beschermen tegen vocht!

 Ikke inkluderet! Beskyt imod fugt!

 No forman parte del suministro! Protegerlo de la humedad!

 Non incluso! Proteggere dall'umidità!

 V ceně není zahrnuto! Chránit před vlhkostí!

29

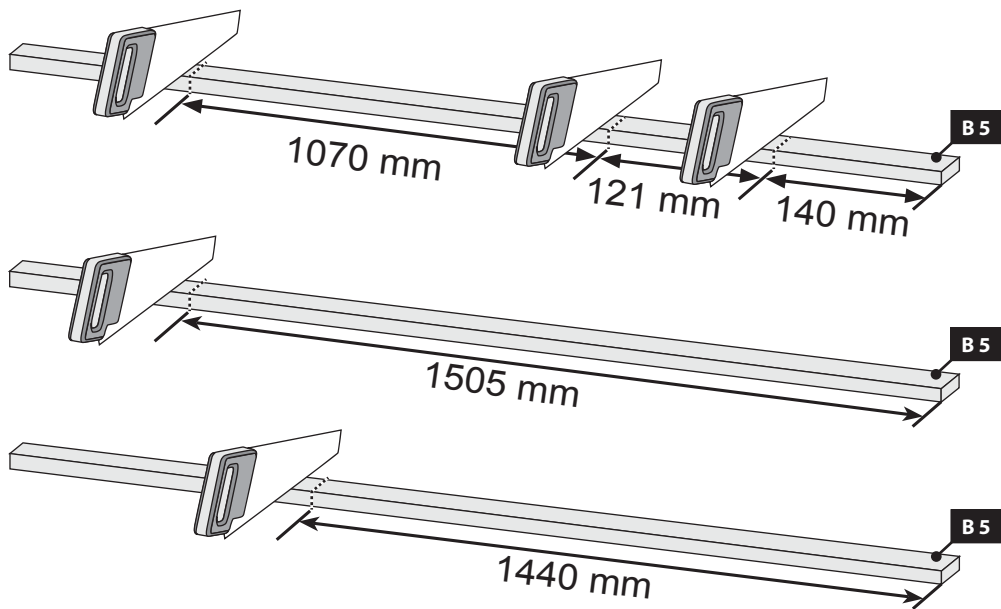

30

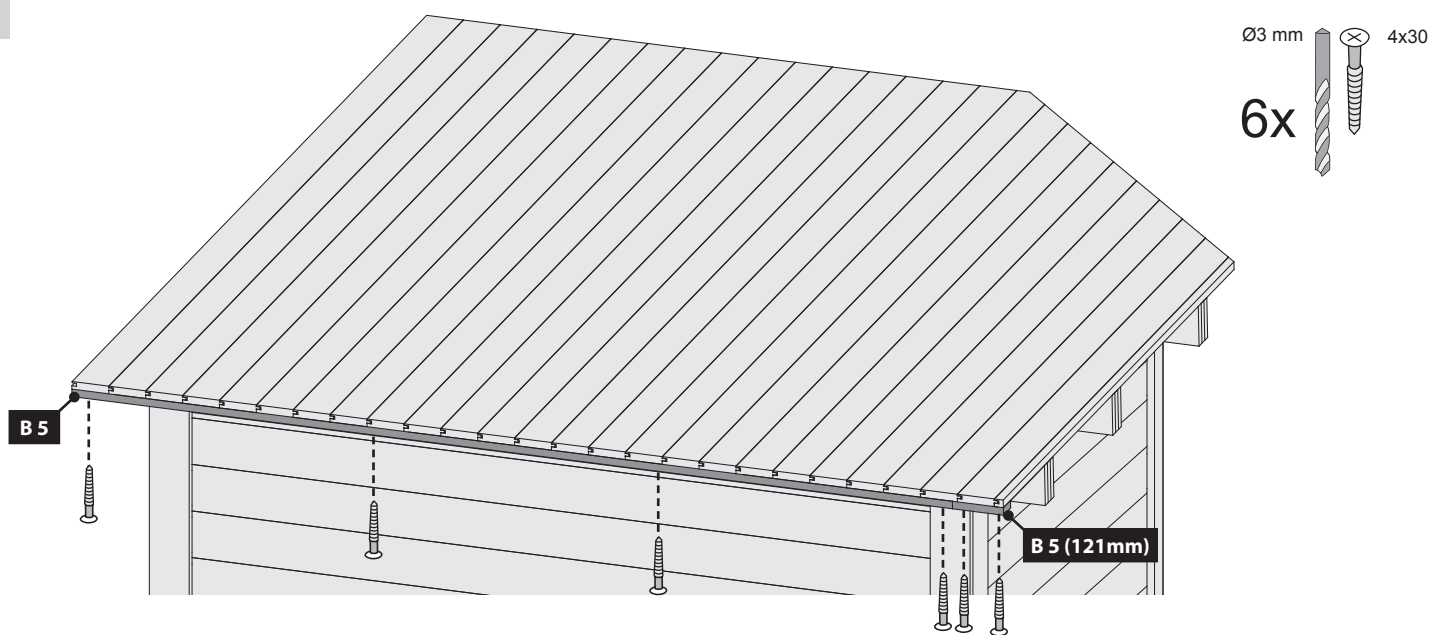

31

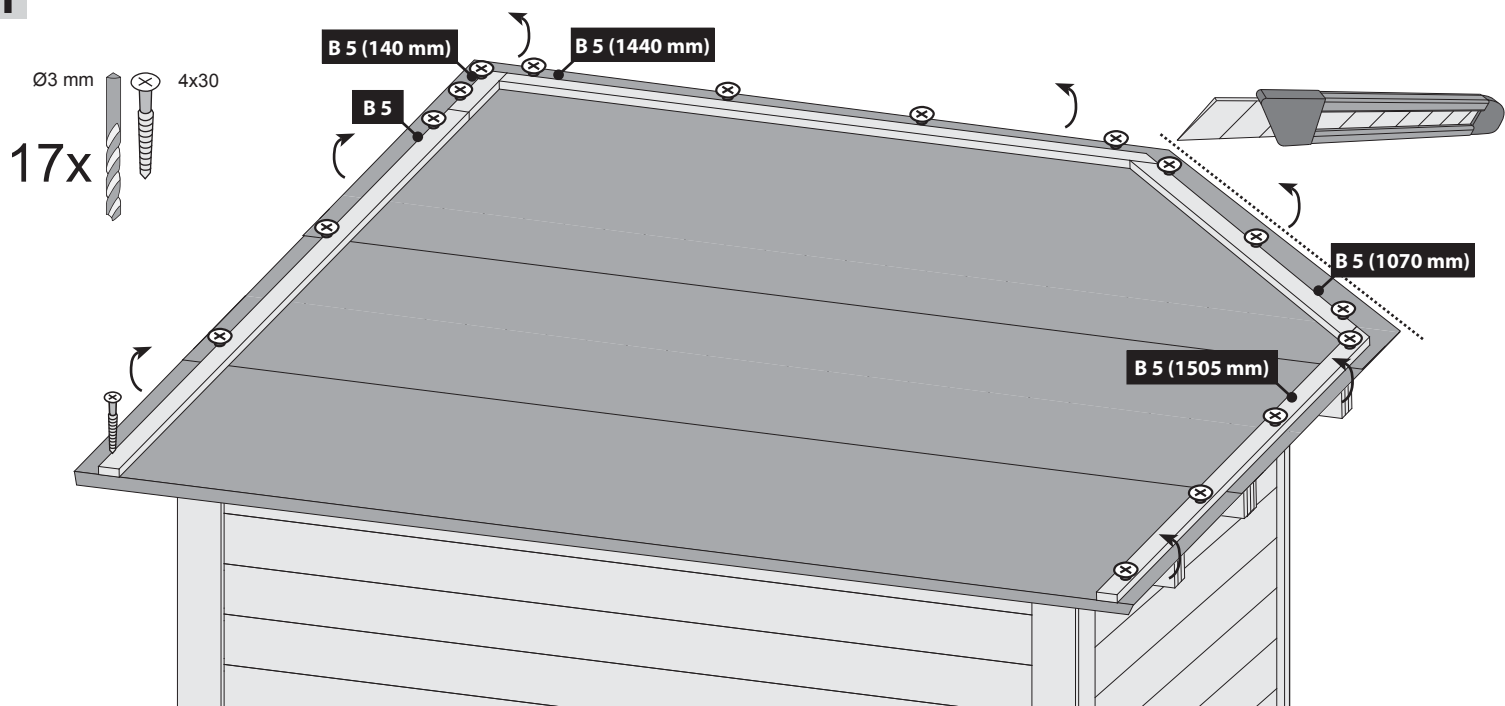



Ø3 mm 13x  
4x50

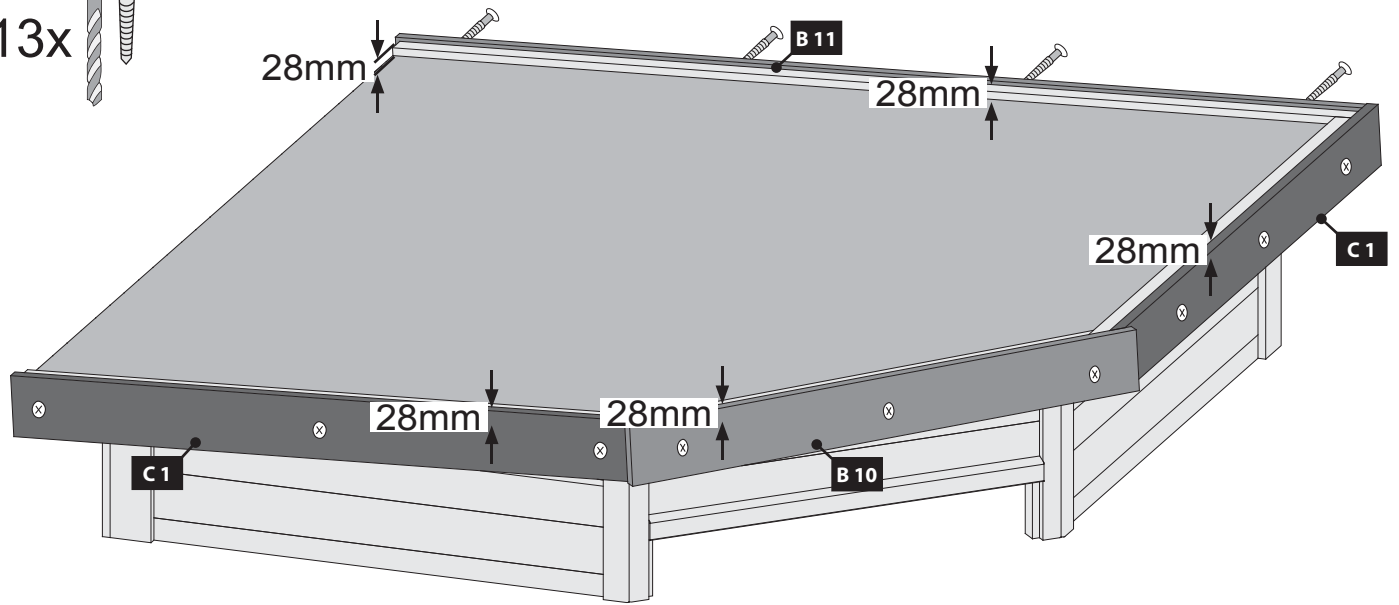

Ø5 mm 2x  
6x60

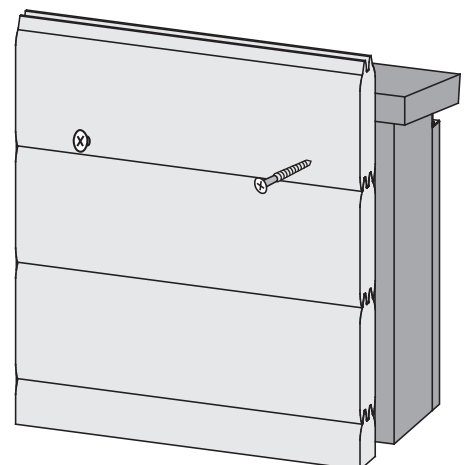
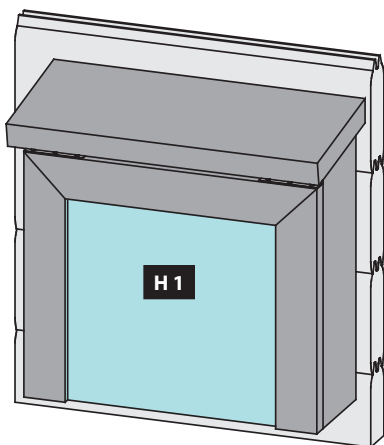



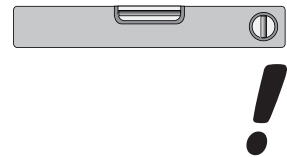
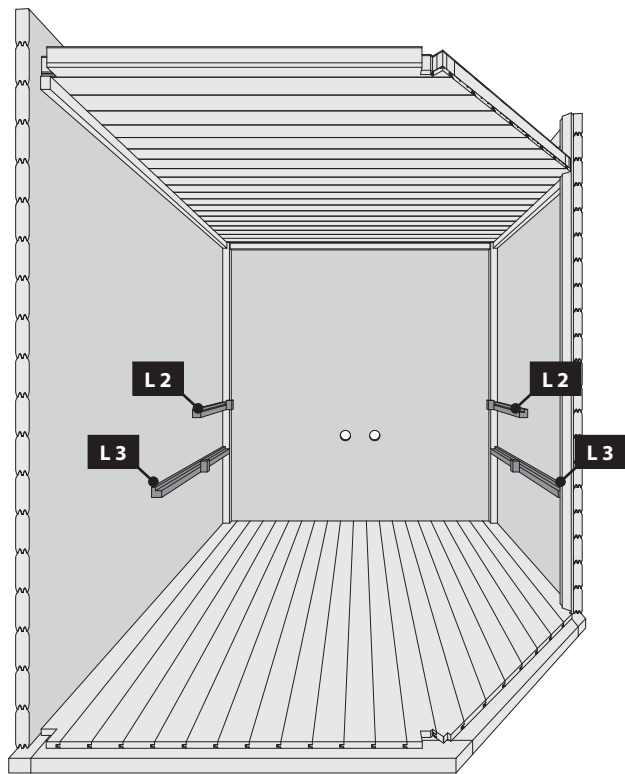

Ø5 mm 6x80

7x

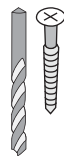

Ø5 mm 6x80

7x

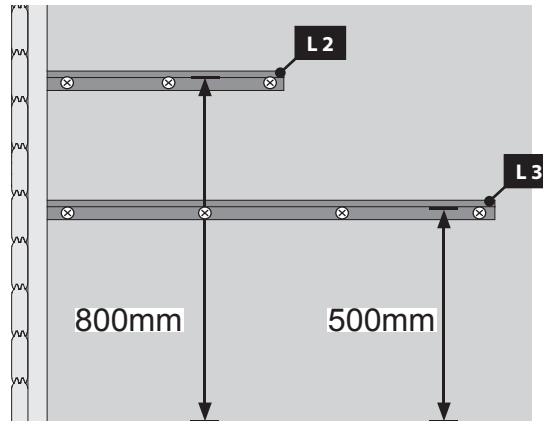
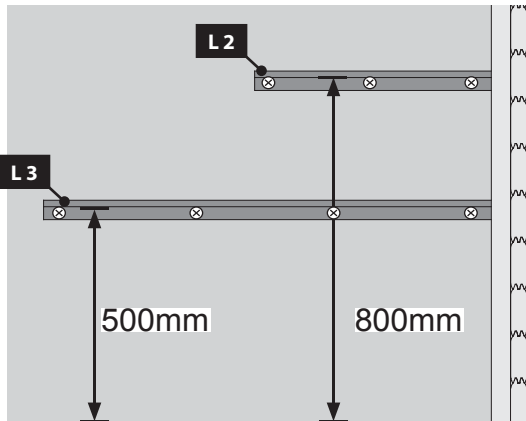
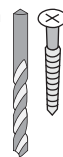

Ø3 mm 4x50

4x

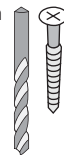

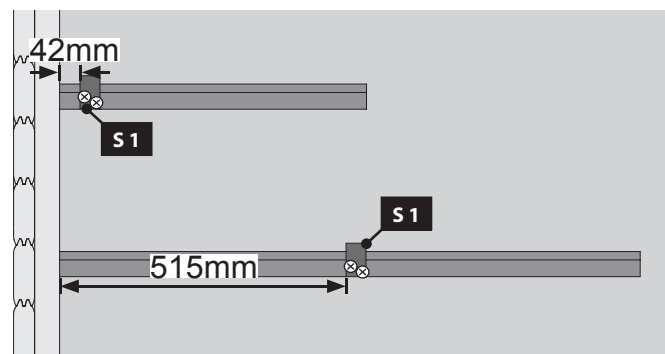
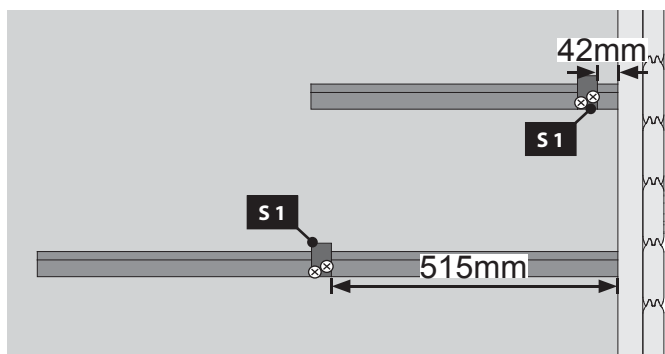
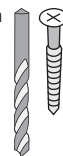

Ø5 mm 4x50

4x

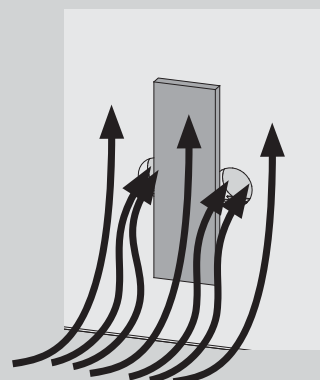
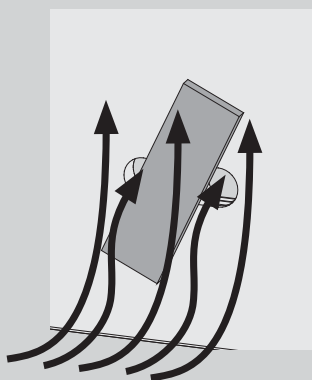
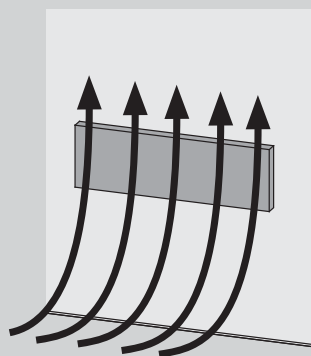
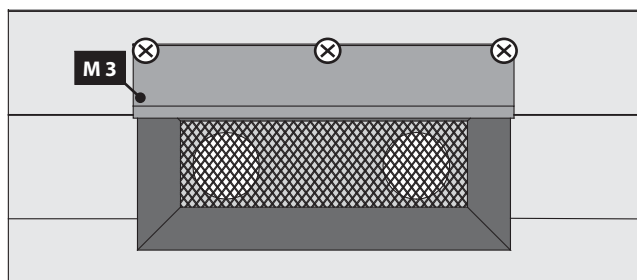
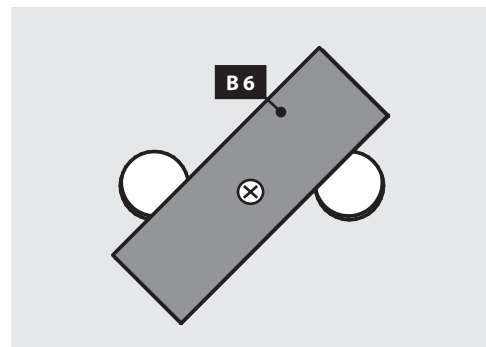
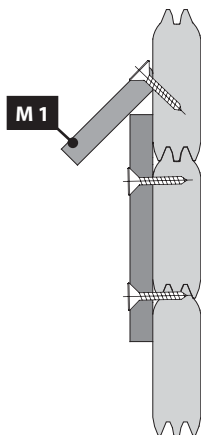
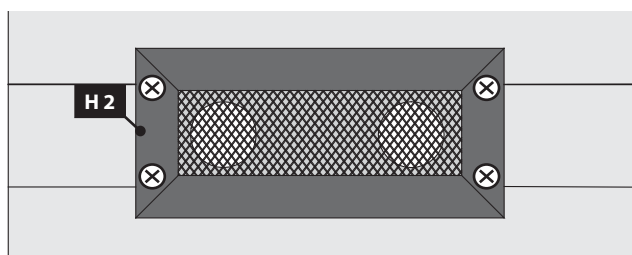
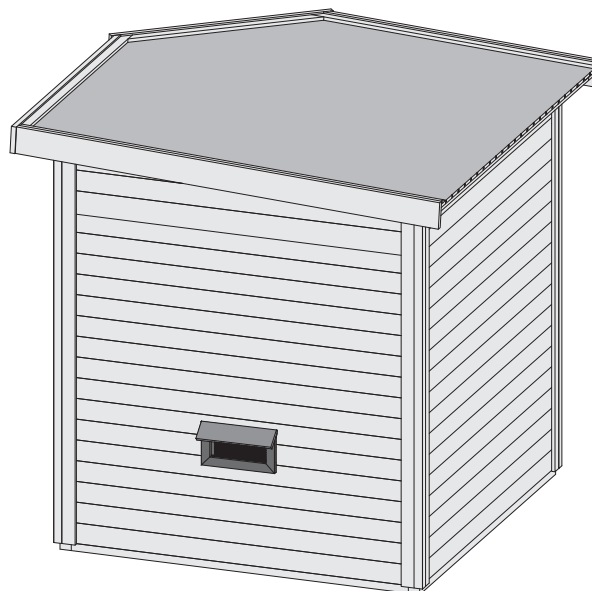
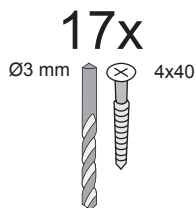





 Hier ist die Funktionsweise des Brettes abgebildet. Regeln Sie damit die Abluft nach Ihren eigenen Wünschen.

 Ceci représente le mode de fonctionnement de la planche. Avec elle, réglez l'écoulement de l'air selon vos désirs.

 This figure shows the functional principle of the board. Regulate the exhaust air according to your own wishes.

 Hier is de werking van het plankje afgebeeld. Regel daarmee de luchtafvoer naar eigen wens.

 Aquí está representada la forma de funcionamiento de la tabla. Regule con ello el aire de salida según sus propios deseos.

 Viene illustrato il principio di funzionamento della tavoletta di regolazione della ventilazione. Con essa si può regolare a piacere la ventilazione.

 Zde je zobrazená funkce desky. Regulujte s ní odsávací vzduch dle Vašeho přání.

 Sådan fungerer styret. Brug den til at regulere udstødningsluften efter dine egne ønsker.

36 2x

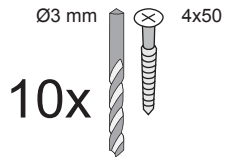
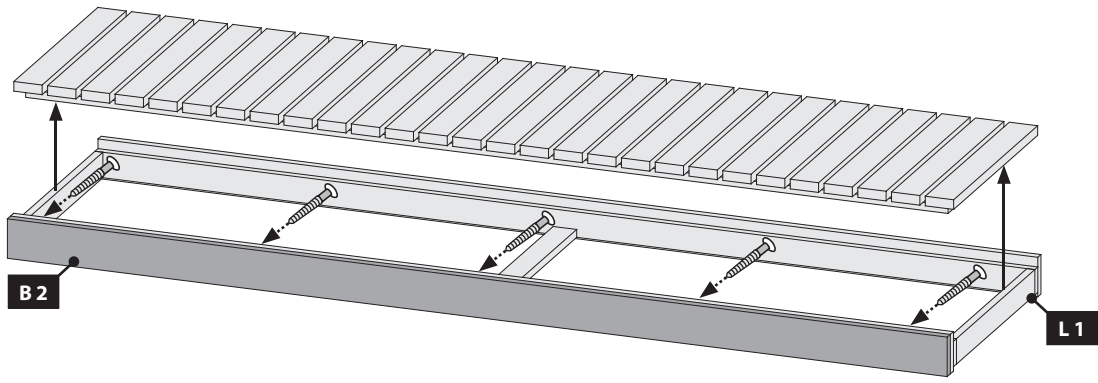
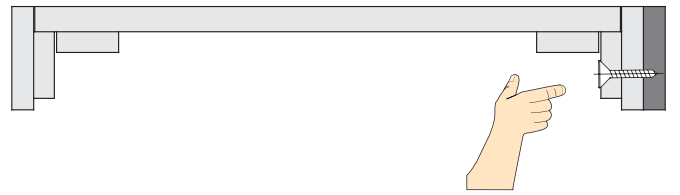

37

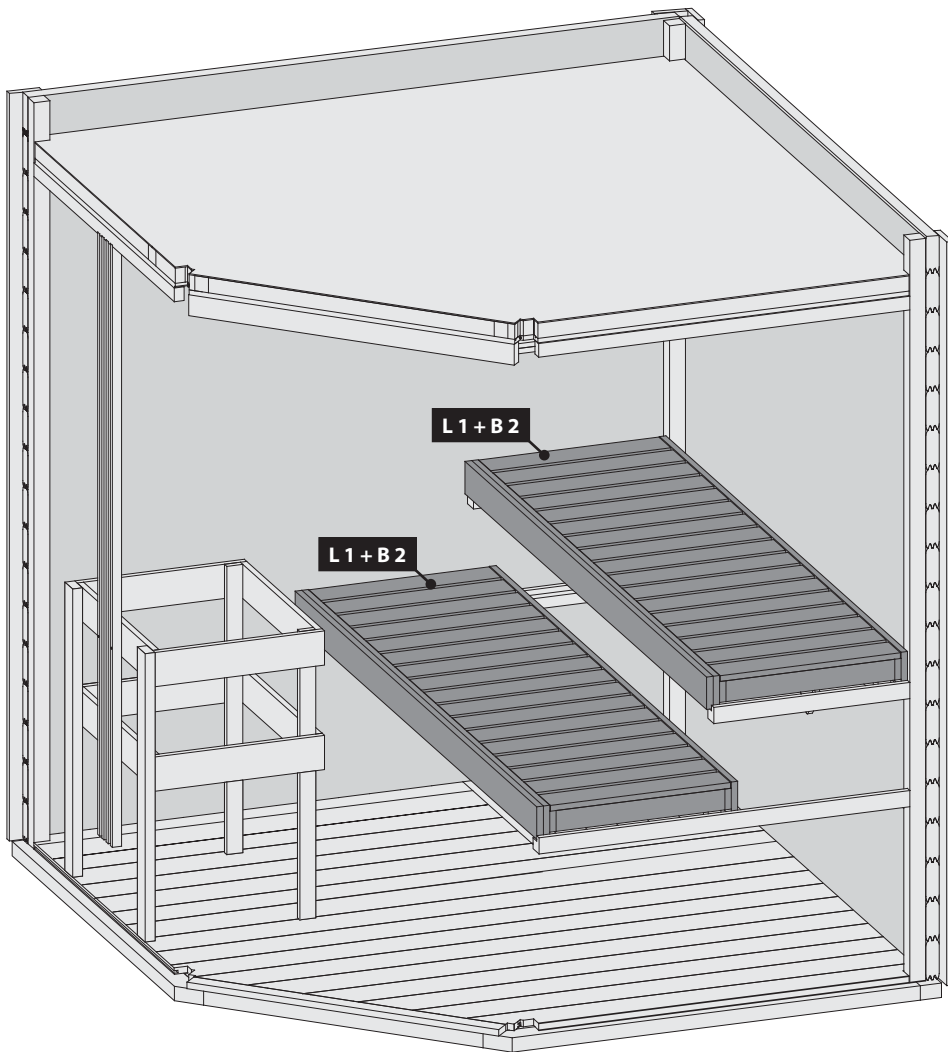

-  Ofenbefestigung
-  oven vaststelling
-  oven fixing
-  fixation four
-  fijación horno
-  fissaggio forno
-  upevňovací trouba
-  ovn fastsættelse

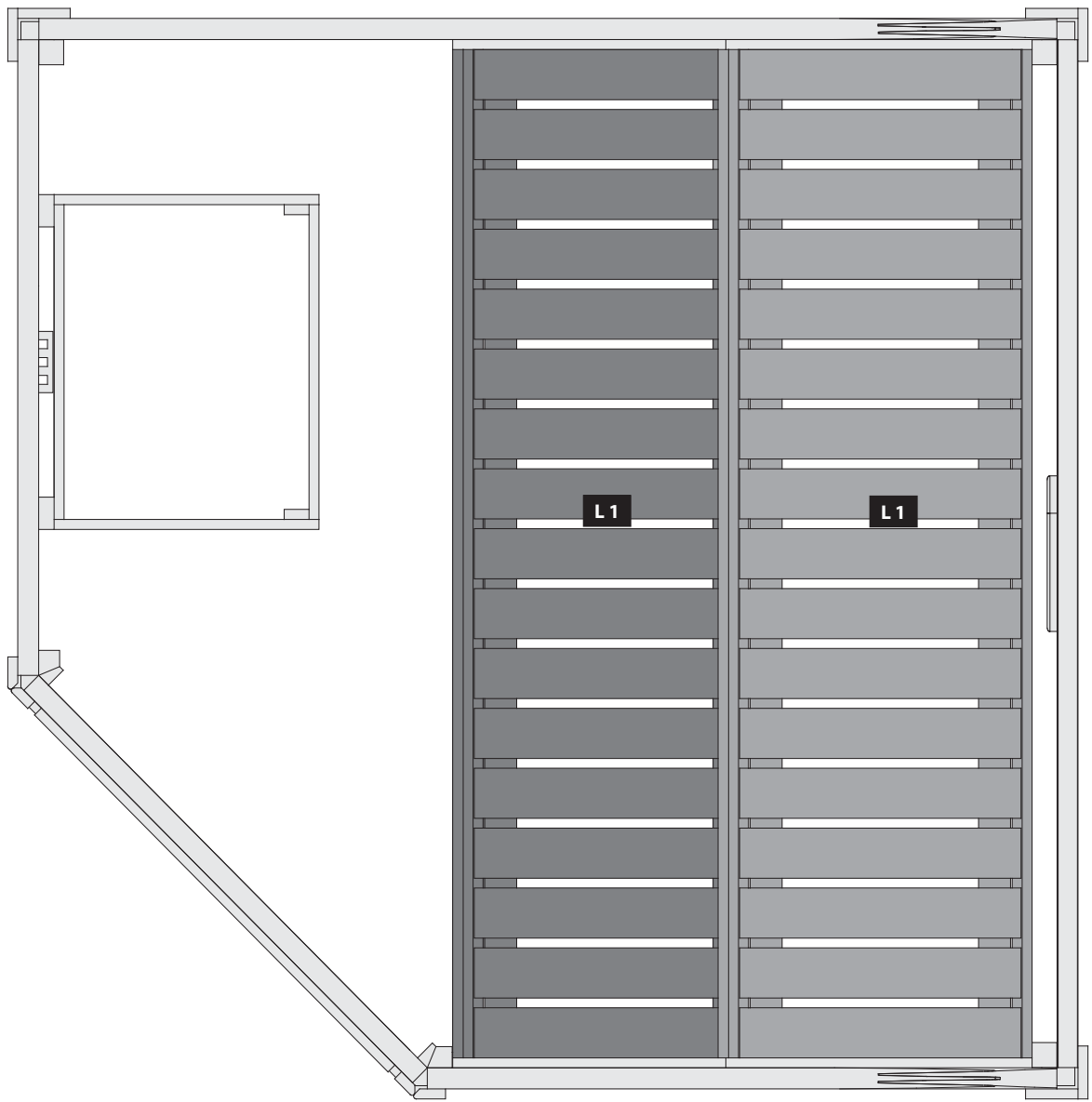
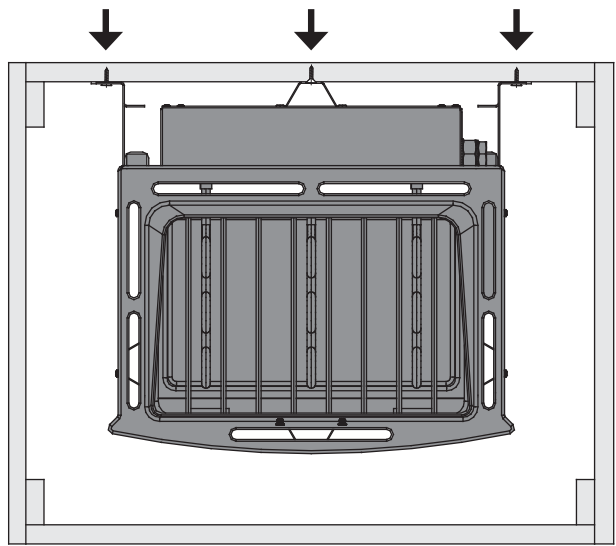
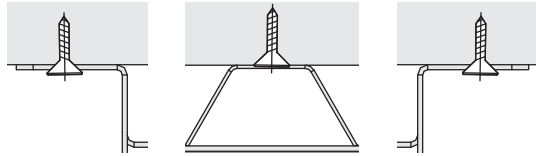

01

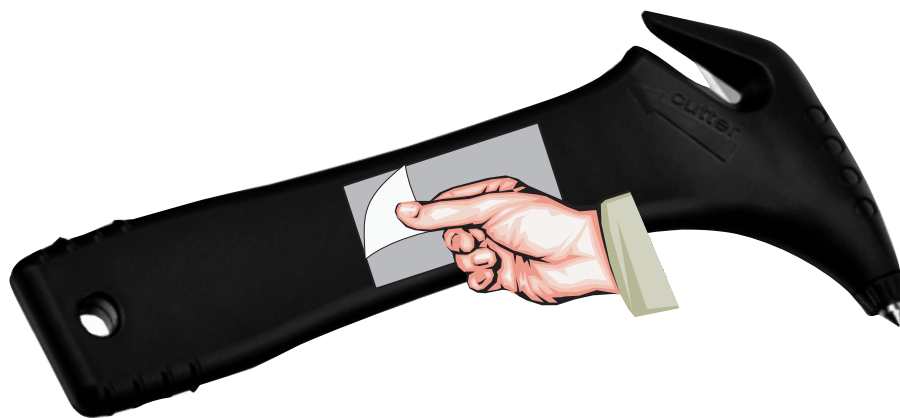

02

