

44293

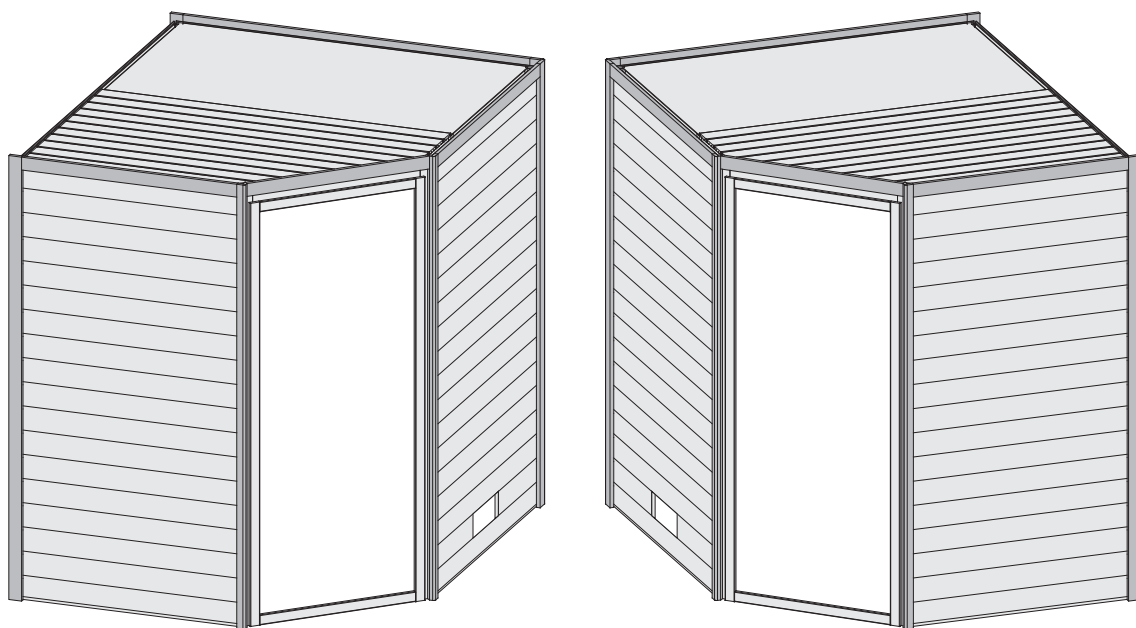

-  **Aufbauanleitung**
-  **Building Instructions**
-  **notice de montage**
-  **montagehandleiding**
-  **Montagevejledning**
-  **Instrucciones de construcción**
-  **Istruzioni per il montaggio**
-  **Montážní návod**
-  **Navodila za sestavljanje**

Bitte bewahren Sie die Anleitung und den Garantieschein zur Seriennummer auf.

Vernichten Sie diese erst nach Ablauf der Garantiezeit.





Eventuelle Beanstandungen können mithilfe der Stückliste einfacher zugeordnet werden.

#### Beigelegte Dokumente

- Informationsheft
- Garantieschein zur Seriennummer
- Typenschild inkl. Warnhinweise (Sauna)
- ggf. Zubehör-Anleitungen in externen Paketen

- \*  Nicht im Lieferumfang enthalten  
 Not included  
 Non comprises dans la livraison  
 Niet bijgeleverd

-  No forman parte del suministro  
 Non incluso  
 V ceně není zahrnuto  
 Ikke inkluderet  
 Ni včlučeno v obseg dobave

- 1  Länge muss ermittelt und zugesägt werden  
 Length must be determined and sawn  
 La longueur doit être déterminée et sciée  
 De lengte moet worden bepaald en worden gezaagd

-  La longitud debe ser determinada y aserrada  
 La lunghezza deve essere determinata e segata  
 Délka musí být určena a rozřezána  
 Længden skal bestemmes og saves  
 Določiti je treba dolžino in jo odrezati po velikosti.

- 2  Nicht gebraucht  
 Not needed  
 Pas nécessaire  
 Niet nodig

-  No es necesario  
 Non necessario  
 Není nutná  
 Ikke nødvendigt  
 Ne uporabljaja se

- 3  Mit Zubehör  
 With accessories  
 Avec accessoires  
 Met toebehoren

-  Con accesorios  
 Con accessori  
 S příslušenstvím  
 Med tilbehør  
 Z dodatki

- 4  Fixiert vorübergehend  
 Fixed temporarily  
 Temporairement fixe  
 Tijdelijk vast

-  Temporalmente fijo  
 Temporaneamente fisso  
 Dočasně pevný  
 Midlertidigt rettet  
 Začasno popravi

- 5  Bestand vom Haus  
 Inventory of the house  
 Inventaire de la maison  
 Inventaris von het huis

-  Inventario de la casa  
 Inventario della casa  
 Inventář domu  
 Inventar af huset  
 Inventarizacija hiše

 Vergleichen Sie zuerst die Material-liste mit Ihrem Paketinhalt! Bitte haben Sie Verständnis, dass Beanstandungen nur im nicht aufgebauten Zustand bearbeitet werden können!

 First compare the list of materials with your package contents! Please understand that complaints can be processed in the non-built status only!

 Commencez par comparer la liste du matériel avec le contenu de votre paquet! Sachez que nous traitons uniquement les réclamations concernant le matériel à l'état non monté!

 Vergelijk eerst de lijst van materialen met de inhoud van uw pakket! Reclamaties kunnen alleen in behandeling worden genomen zolang de onderdelen nog niet zijn gemonteerd!

 Start med at kontrollere materialelisten med indholdet af den leverede pakke! Vi gør venligst opmærksom på at reklamationer kun kan behandles for materialer som ikke er blevet bearbejdet!

 En primer lugar, compare la lista de material con el contenido del paquete. Rogamos entienda que las reclamaciones sólo pueden ser tramitadas antes de montar el objeto!

 Confrontate questa distinta materiali prima con il contenuto del pacchetto! Vi preghiamo di comprendere che eventuali reclami possono essere accolti solo prima del montaggio!

 Nejprve přezkontrolujte obsah balení podle materiálového listu! Mějte pochopení pro to, že případnou reklamaci se můžeme zabývat pouze tehdy, když díly nebudou smontované! Za pomoci tohoto seznamu můžete jednotlivé díly přiřadit k montážnímu návodu.

 Najprej primerajte zoznam materialov z vsebino vašega paketa! Upoštevajte, da lahko pritožbe obravnavamo le v nesestavljenem stanju!

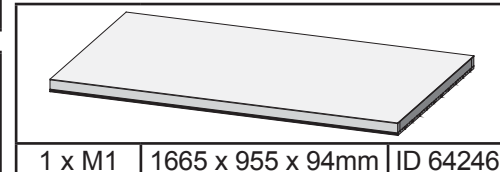
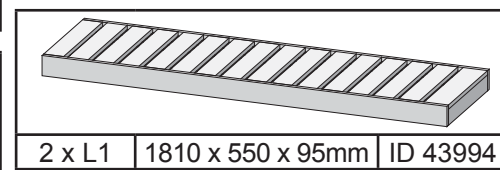
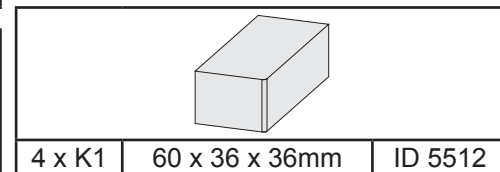
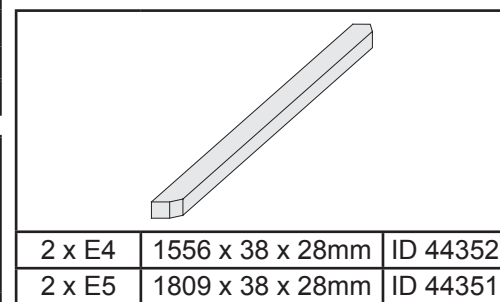
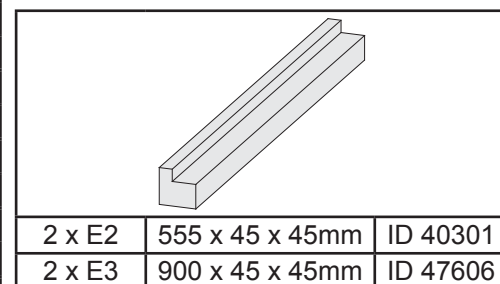
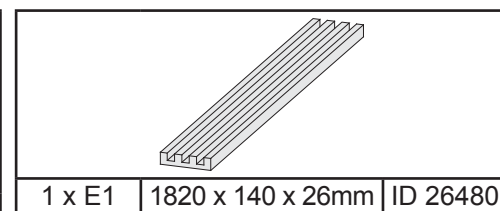
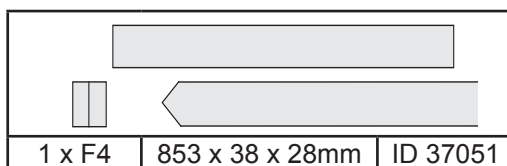
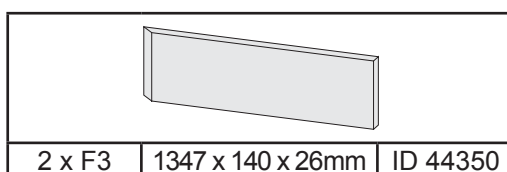
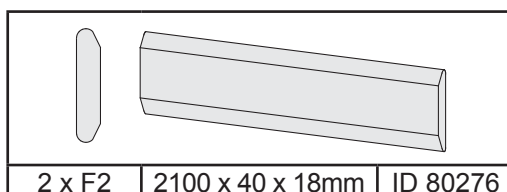
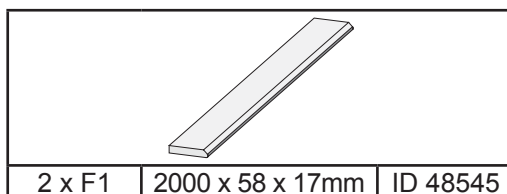
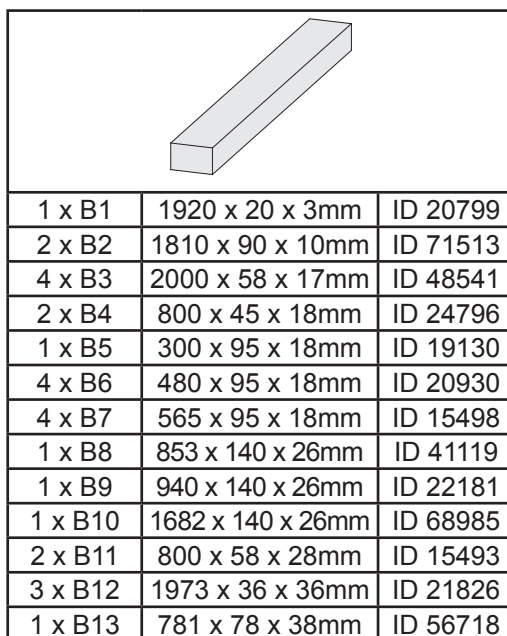
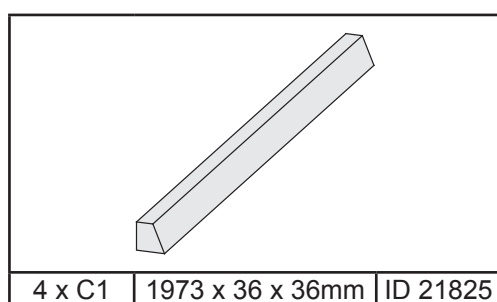
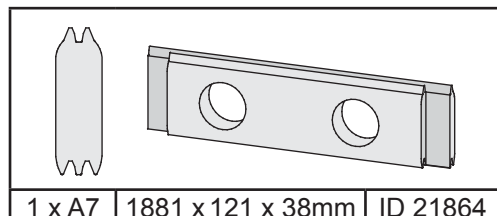
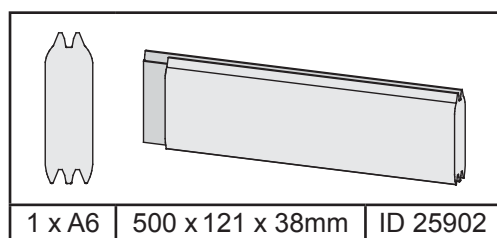
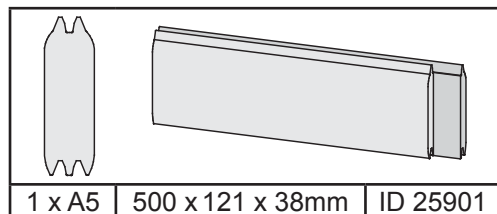
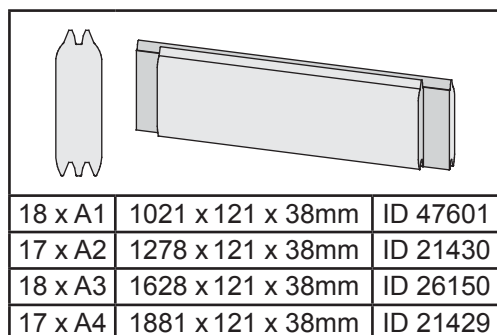
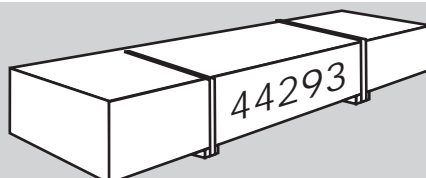

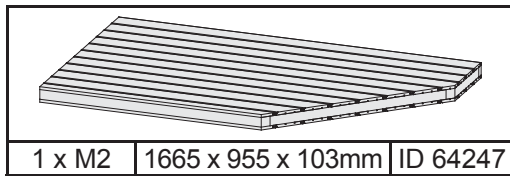

1 x M2 | 1665 x 955 x 103mm | ID 64247

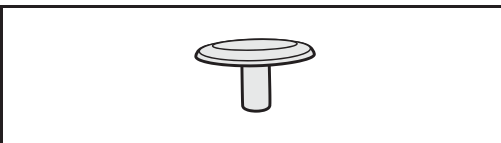

48 x S1 | 4 x 30mm | ID 26116  
6 x S2 | 12 x 18mm | ID 46403

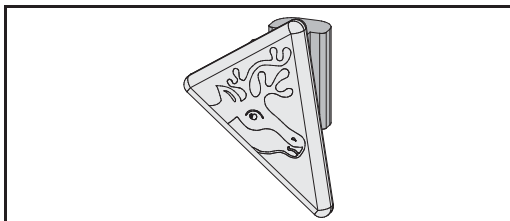

1 x | ID 26114

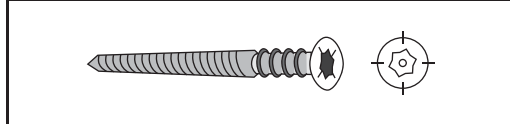

6 x | 6 x 80 mm | ID 14266

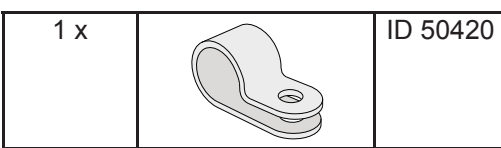

1 x | ID 50420

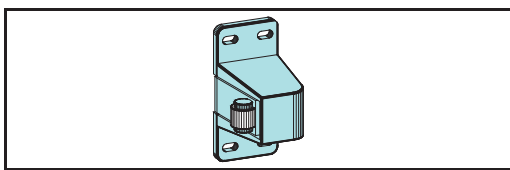

1 x R1 | ID 64245

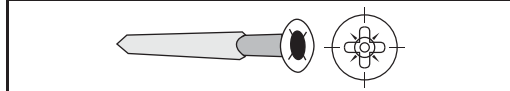

48 x | 4,5 x 40mm | ID 26285

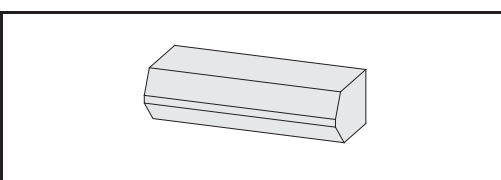

1 x Z1 | ID 64800

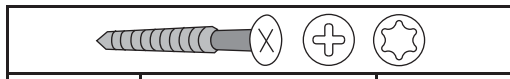

14 x	4 x 30mm	ID 3686
45 x	4 x 35mm	ID 3687
231 x	4 x 40mm	ID 21925
26 x	4 x 50mm	ID 3688
30 x	4 x 70mm	ID 3689
8 x	4,5 x 80mm	ID 9204
2 x	6 x 60mm	ID 14014
14 x	6 x 80mm	ID 47558
72 x	6 x 90mm	ID 26715

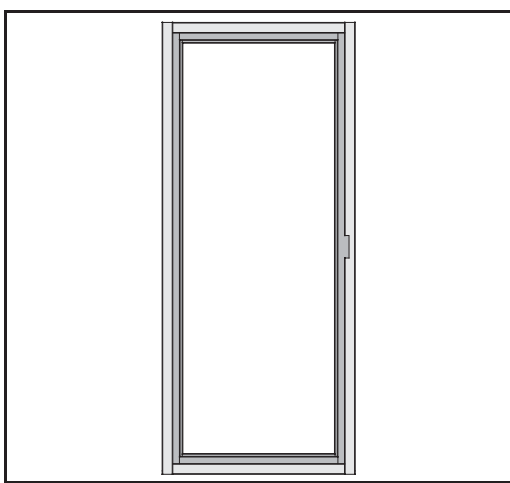

1 x D1 (2) | ID 70351

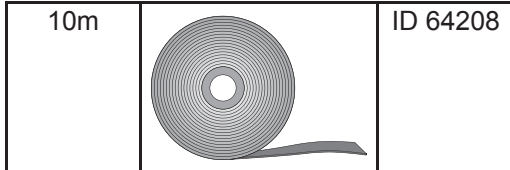

10m | ID 64208

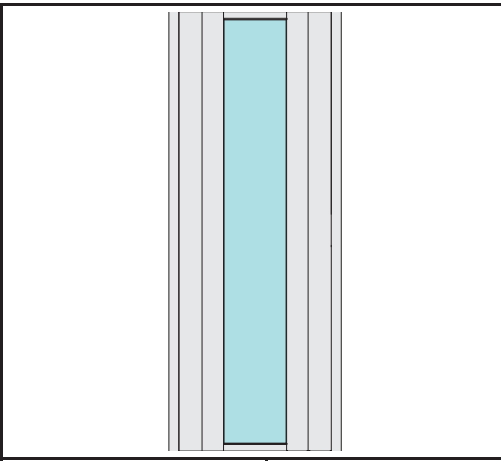

1 x D1 (1) | ID 64238

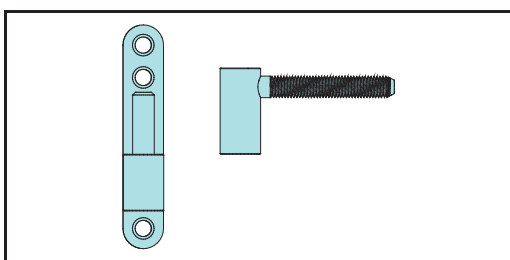

3 x | ID 3717

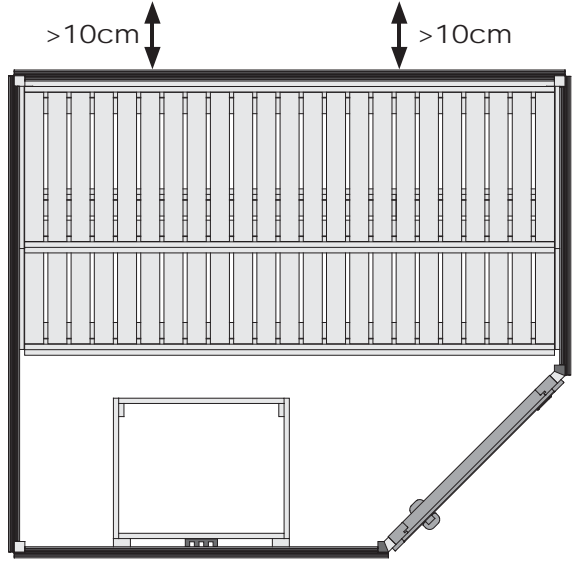
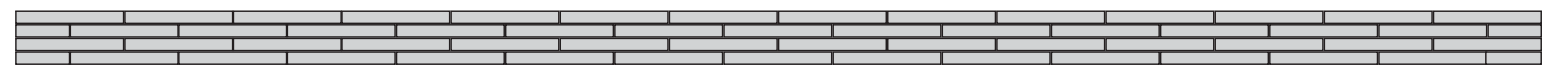



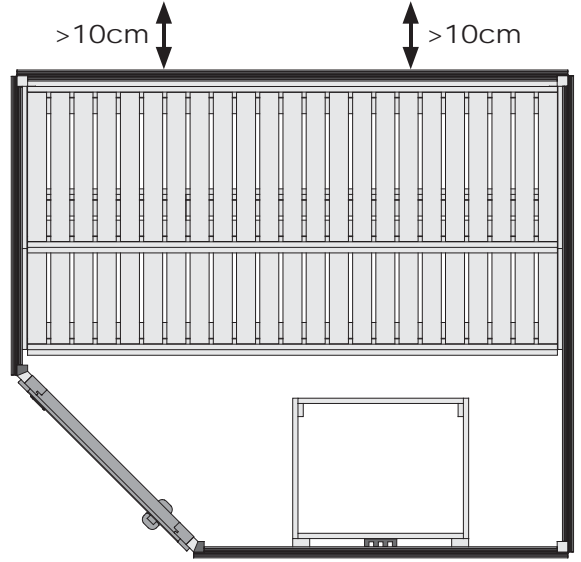



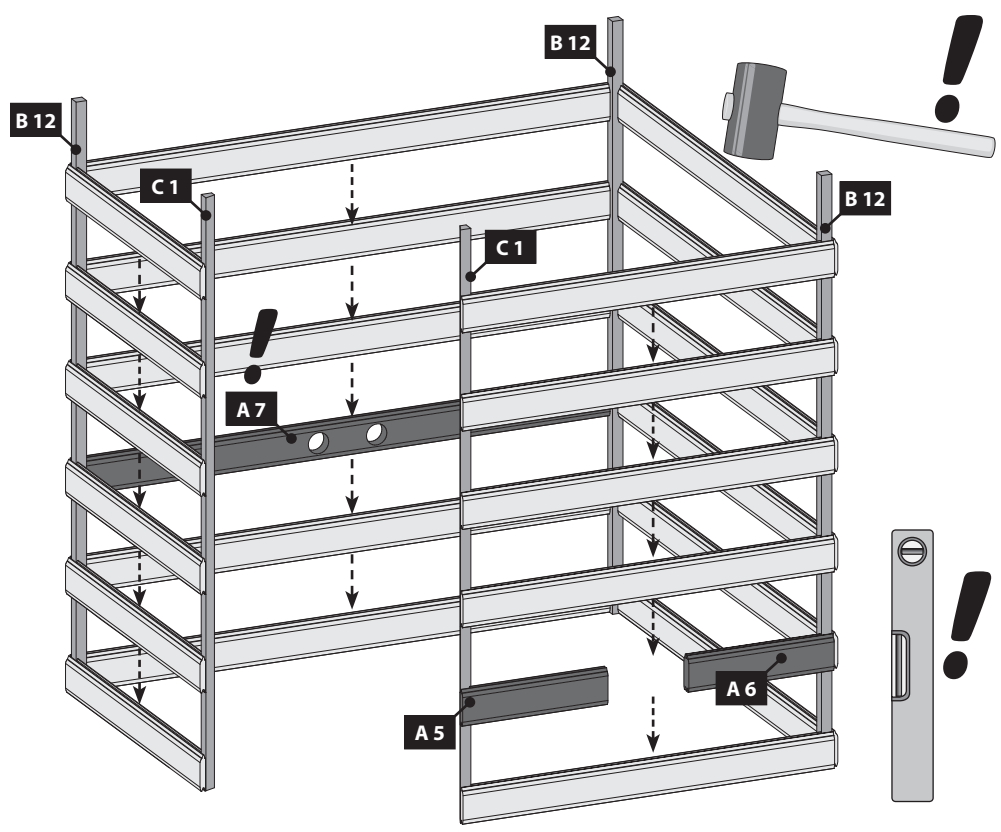

-  Draufsicht
-  Top view
-  vue de dessus
-  Øverste visning
-  bovenaanzicht
-  vista desde arriba
-  vista dall'alto
-  pùdorys
-  Pohľad od zgoraj







-  Achten Sie auf die gleiche Höhe
-  Look for the same height
-  Faites attention à la même hauteur
-  Besteed aandacht aan de dezelfde hoogte
-  Besteed aandacht aan de dezelfde hoogte

-  Prestar atención a la misma altura
-  Prestare attenzione alla stessa altezza
-  Dávejte pozor na stejnou výšku
-  Vær opmærksom på samme højde

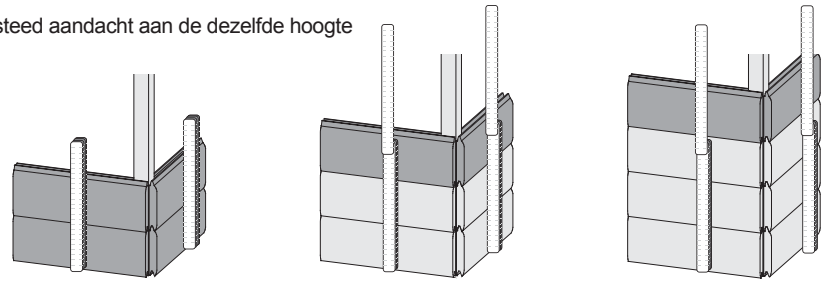

### 02.1

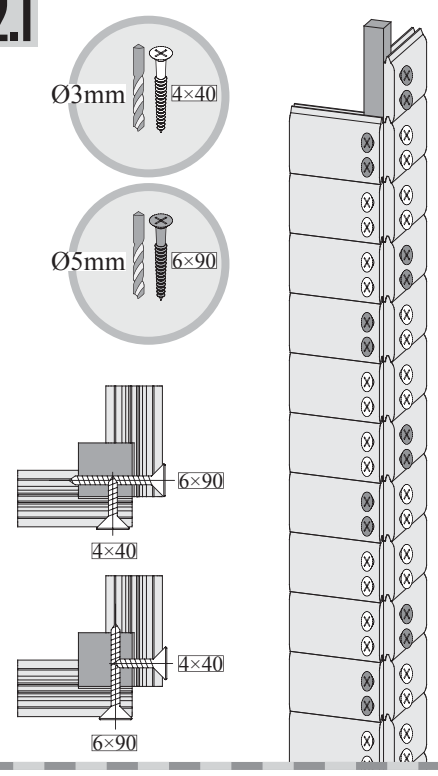

### 02

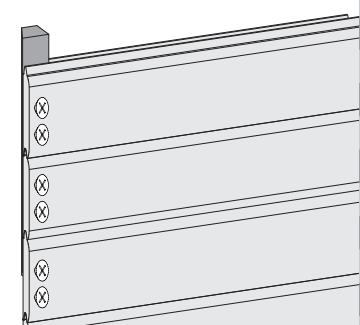
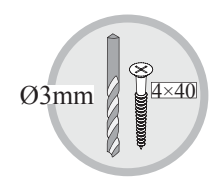
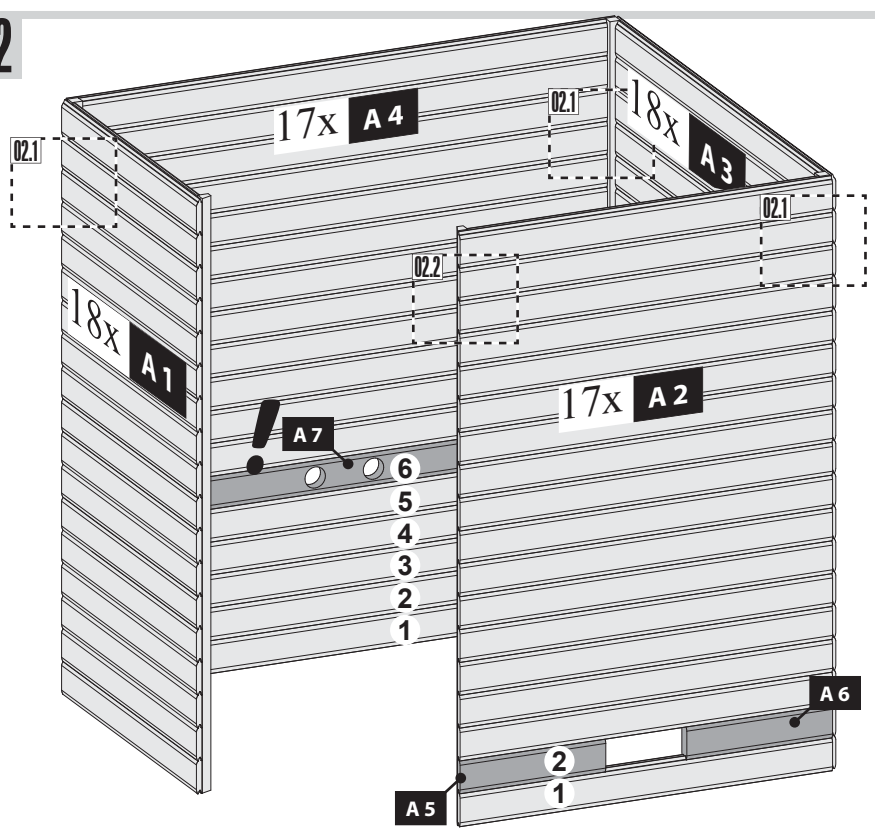

03

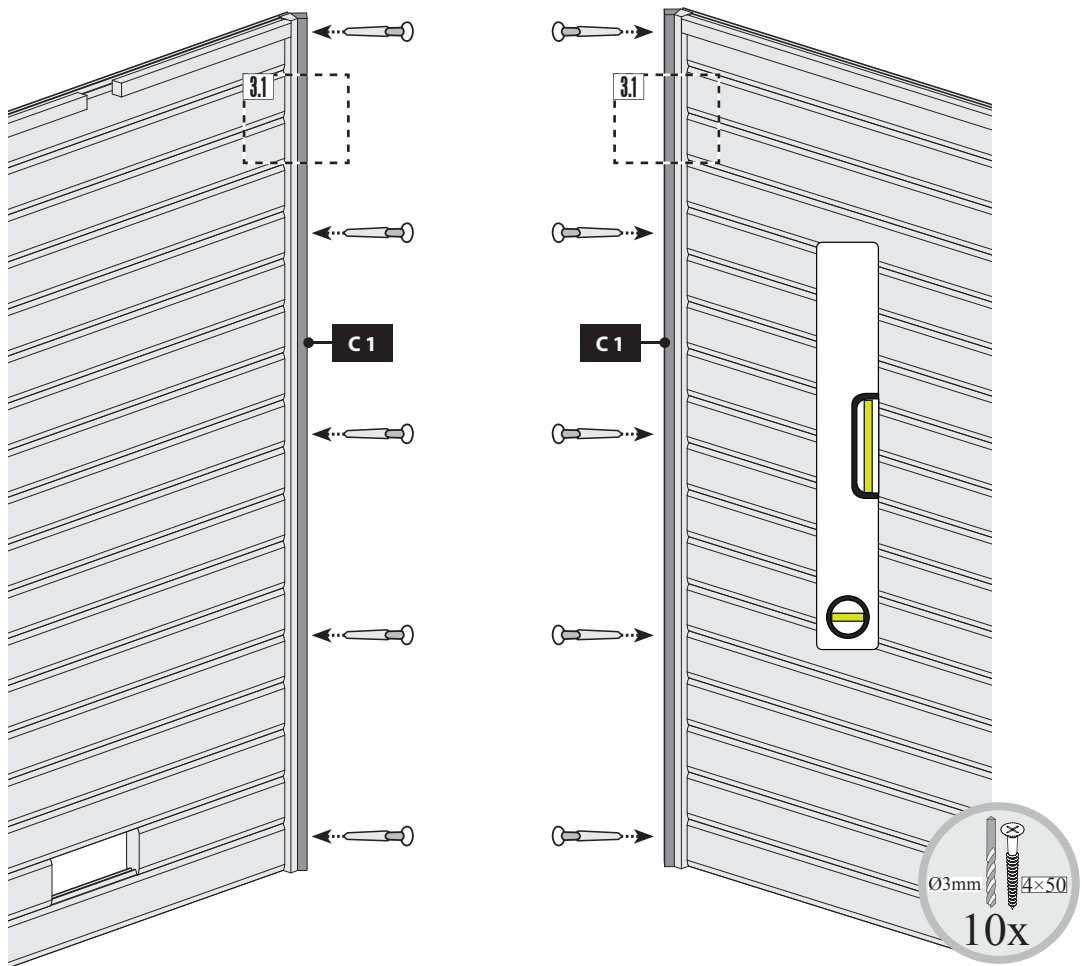

03.1

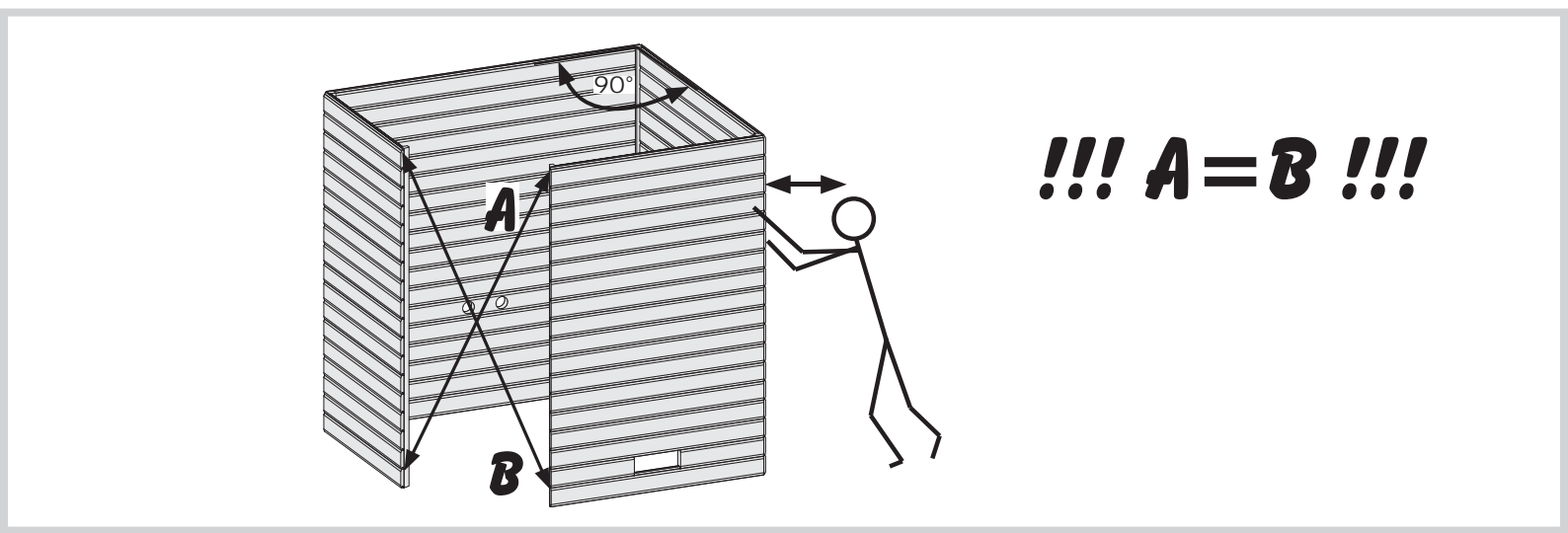
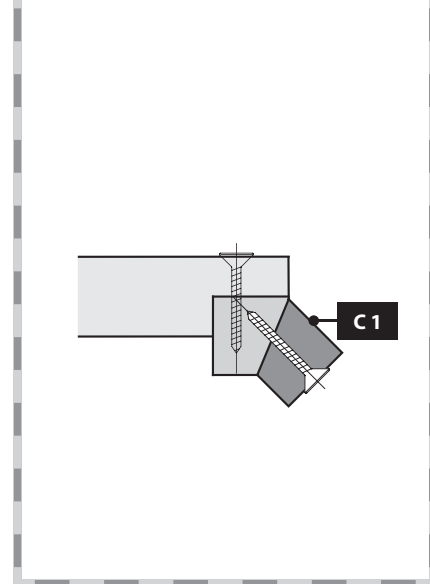

04

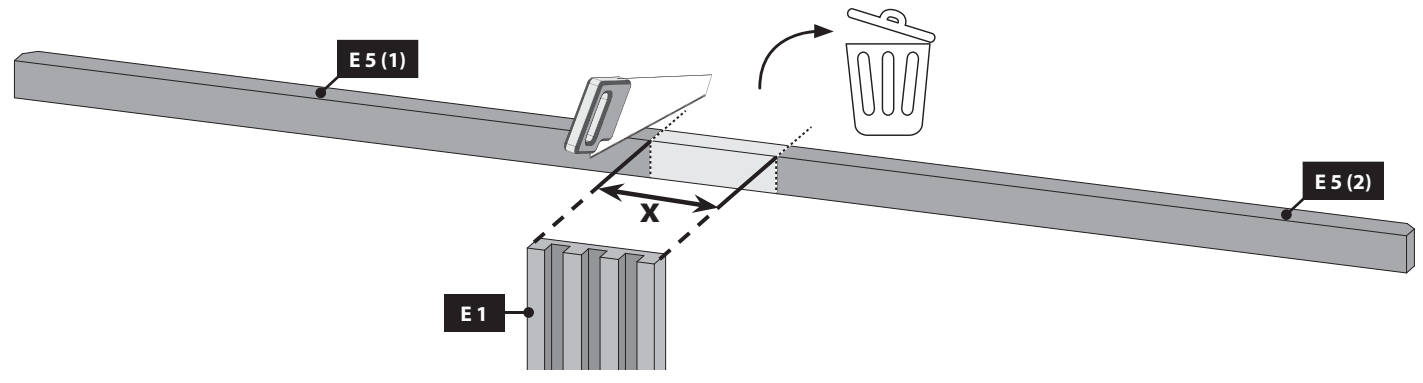

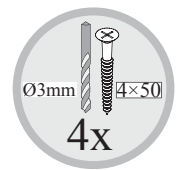
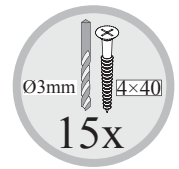
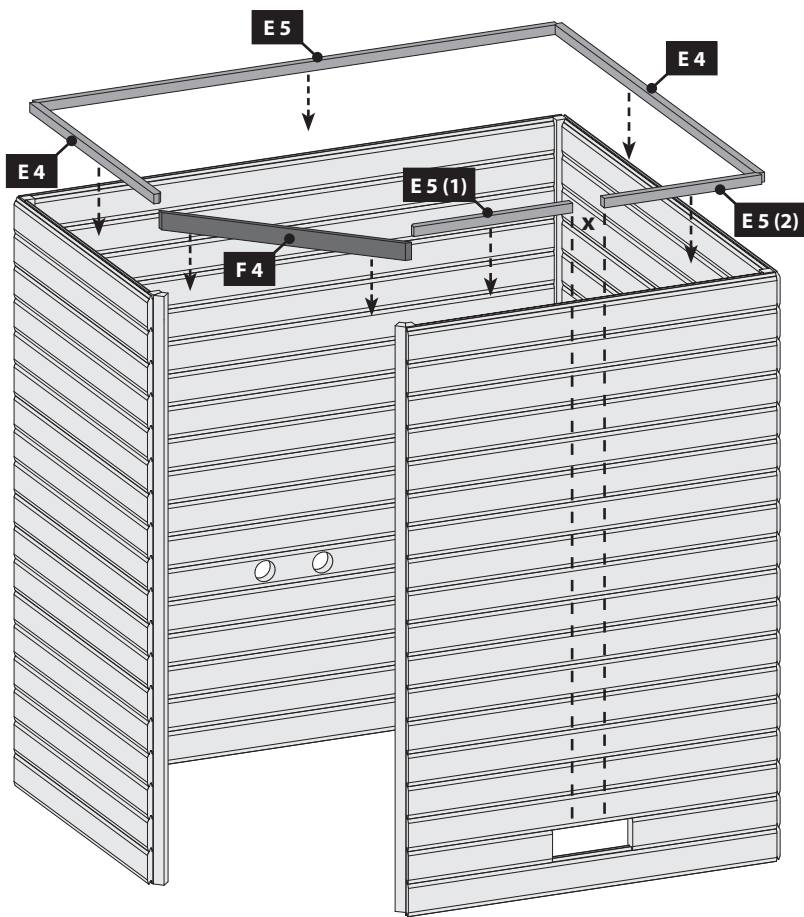

05.1

-  Bündig!
-  Flush!
-  Affleurement!
-  Gelijk!
-  I flugt!
-  Aras!
-  Combacia!
-  Stejný!
-  Splakovanje!

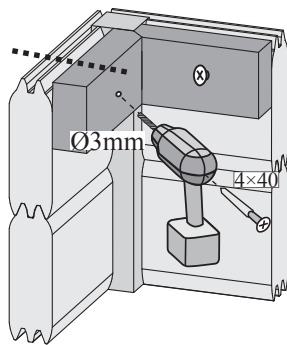

05.2

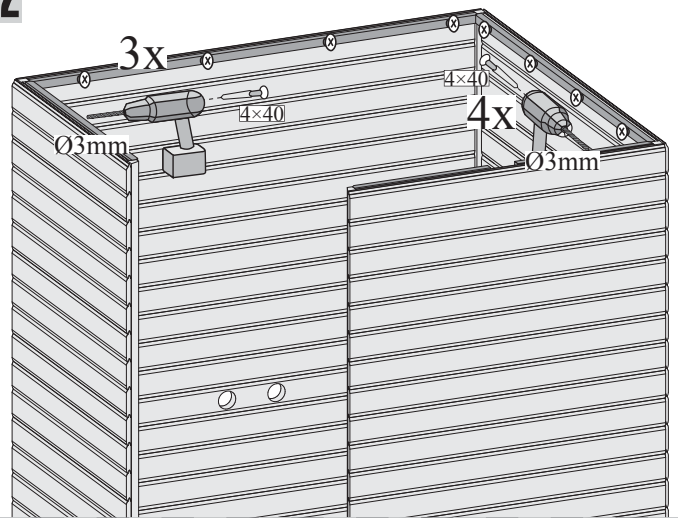

05.3

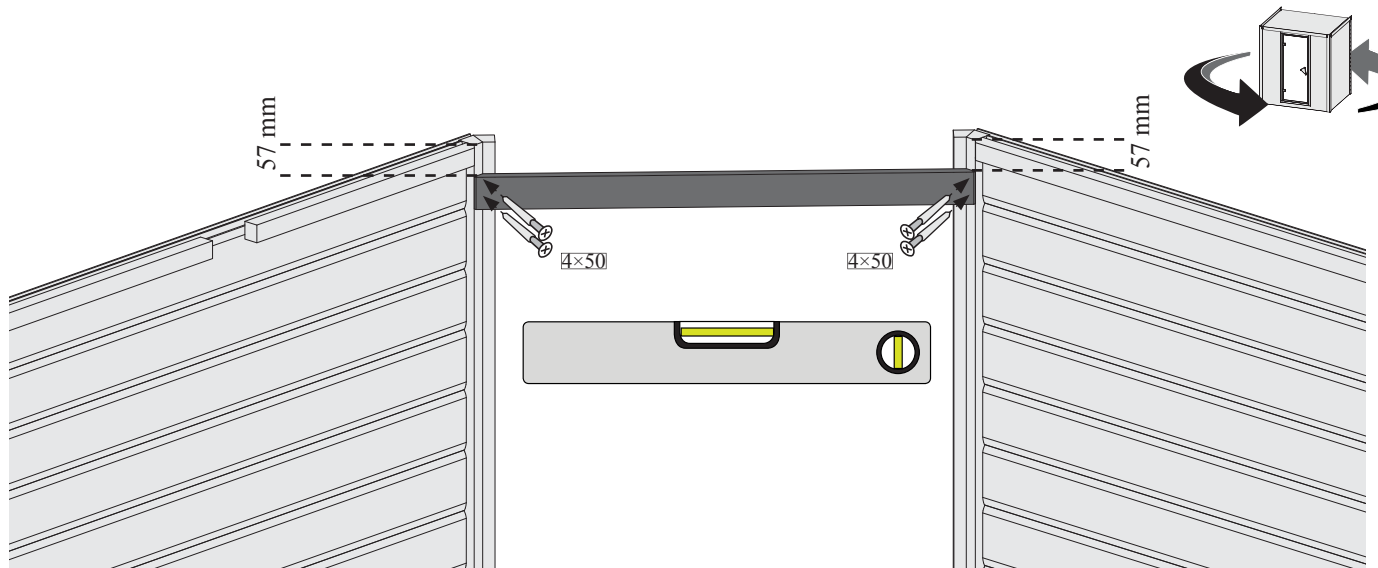



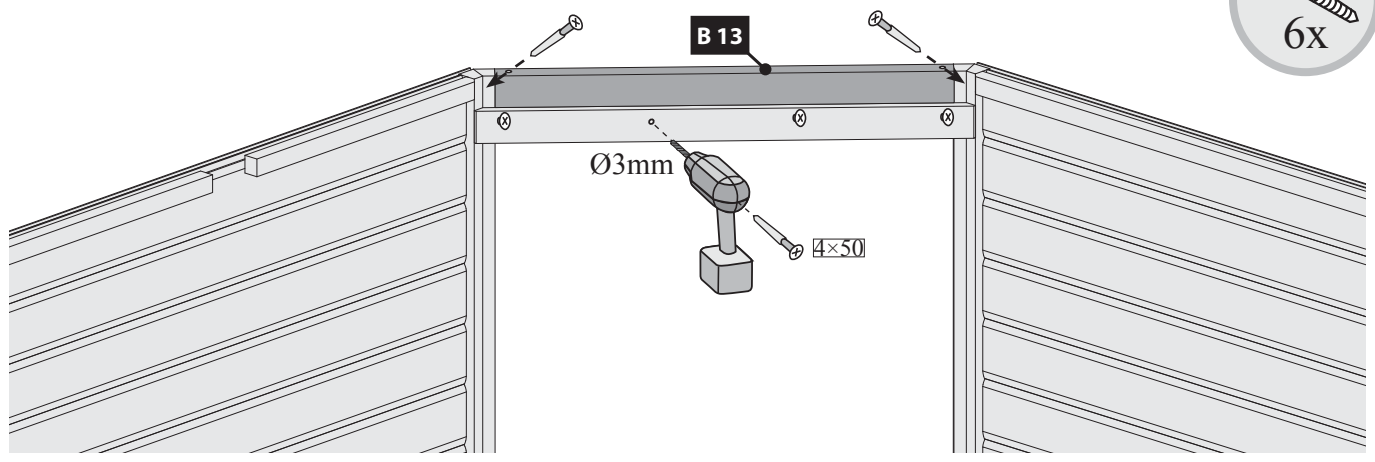

06.1

-  Bündig!
-  Flush!
-  Affleurement!
-  Gelijk!
-  I flugt!
-  Aras!
-  Combacia!
-  Stejný!
-  Splakovanie!

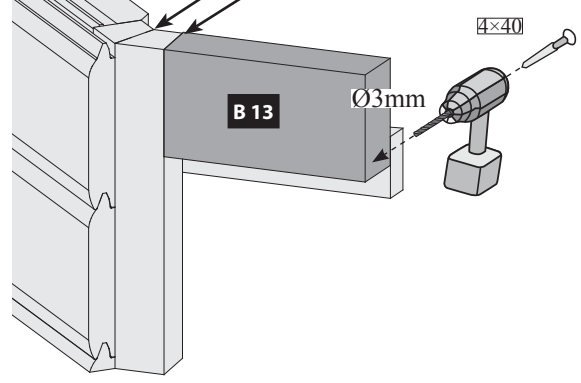

06.2

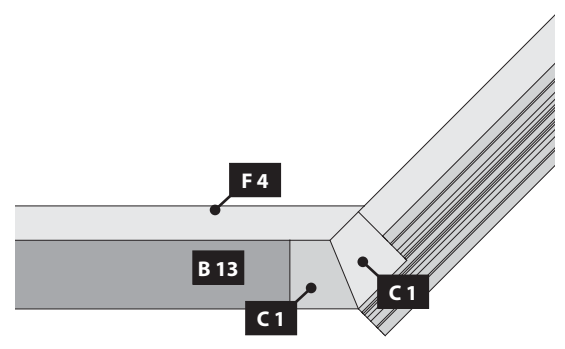

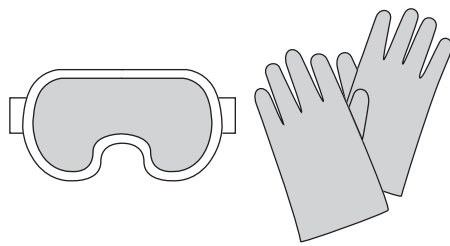

07

-  Tür in den Rahmen legen
-  Put the door in the frame
-  Mettez la porte dans le cadre
-  Plaats de deur in het frame
-  Sæt døren i rammen
-  Pon la puerta en el marco
-  Metti la porta nel telaio
-  Vložte dveře do rámu
-  Vrata namestite v okvir

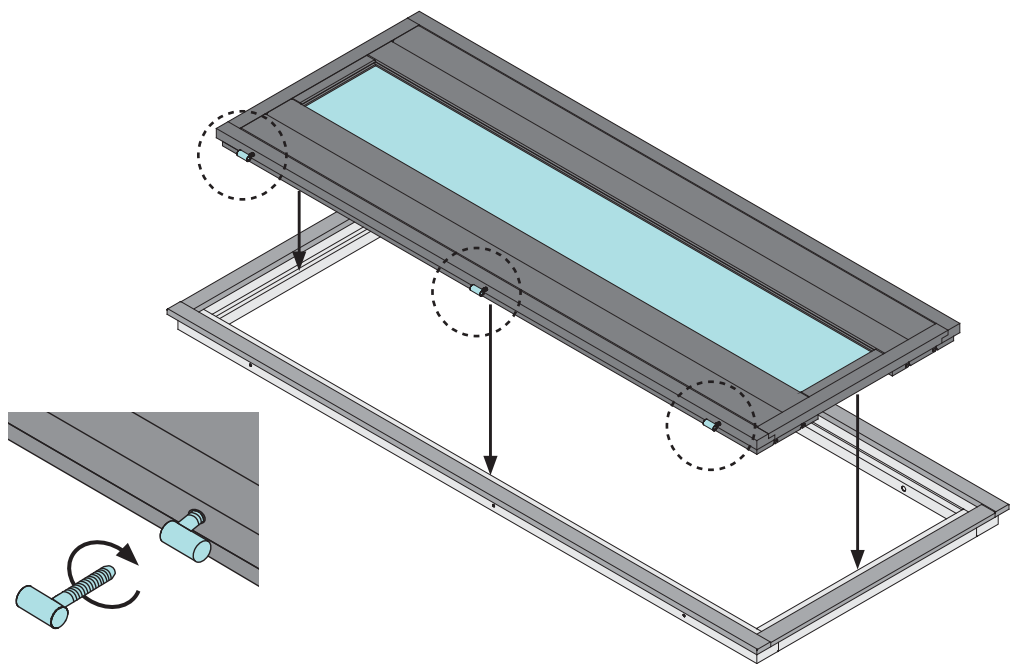

08

-  Tür im Rahmen ausrichten
-  Center the door in the frame
-  Aligner la porte dans le cadre
-  Lijn de deur in het frame uit
-  Juster døren i rammen
-  Alinea la puerta en el marco
-  Allinea la porta nella cornice
-  Zarovnejte dveře do rámu
-  Poravnajte vrata v okvir

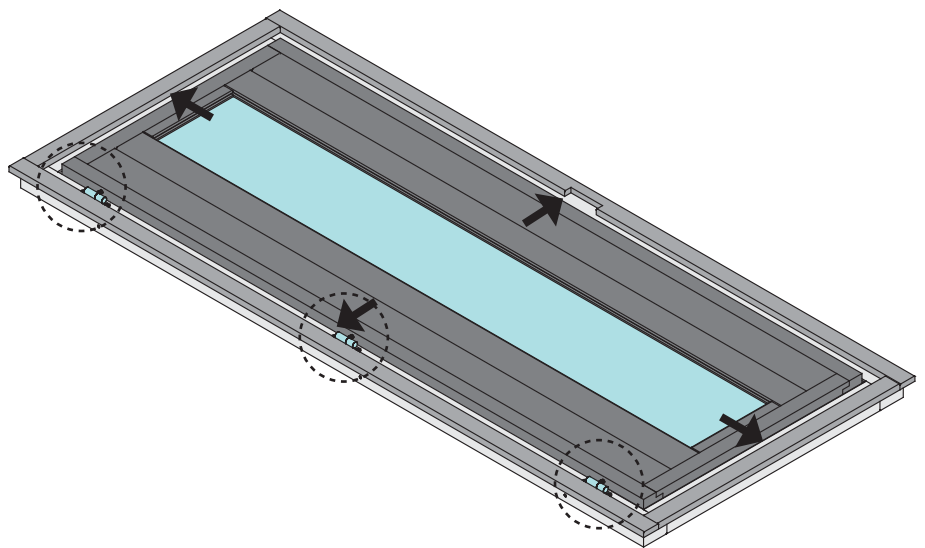

1.

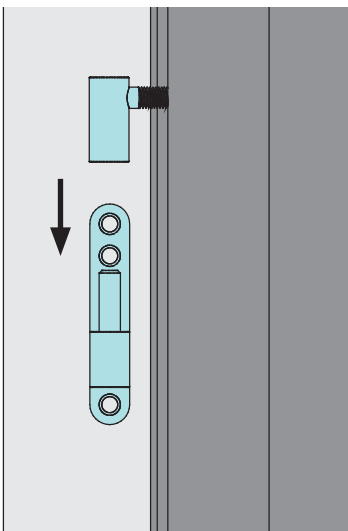

2.

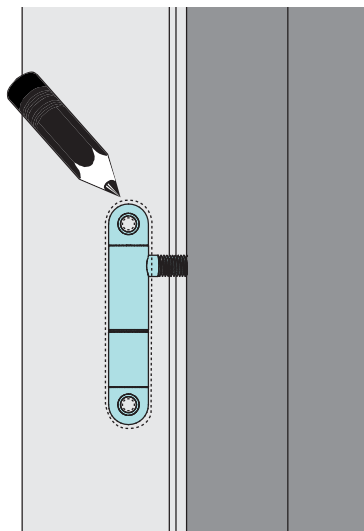

3.

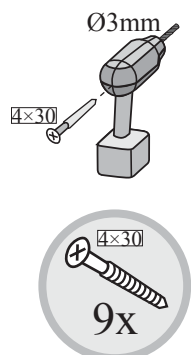
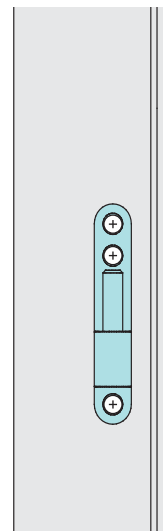

1.

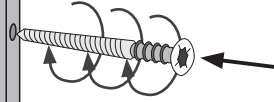
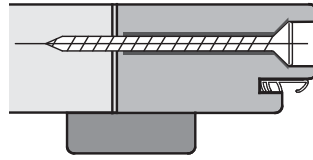
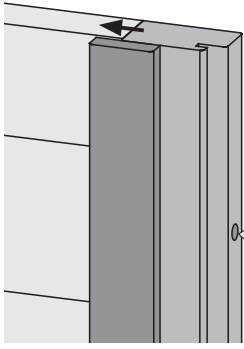

2.

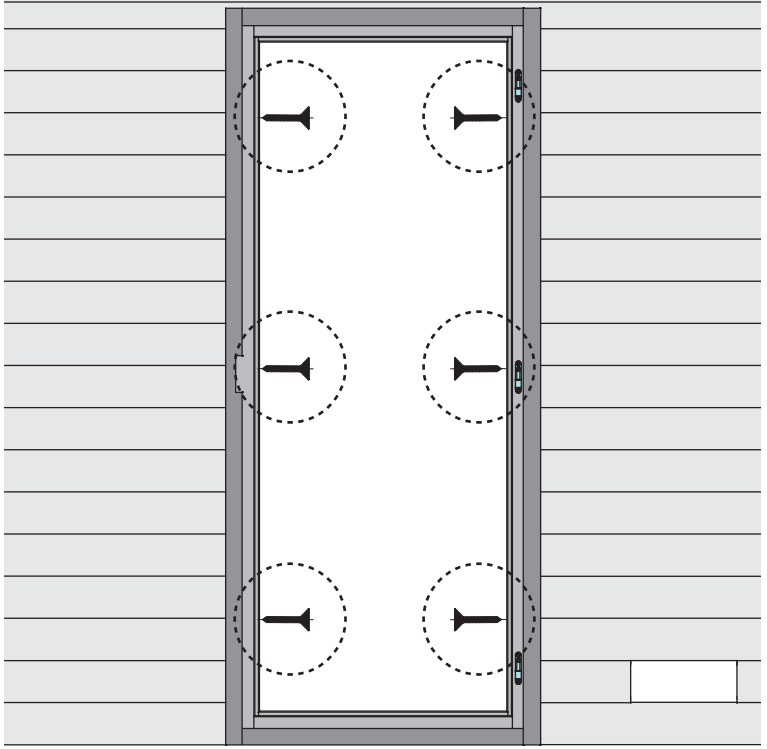
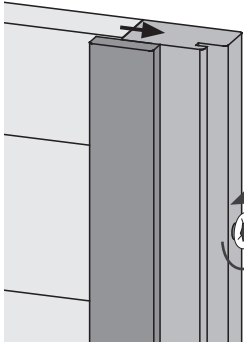

# 1.

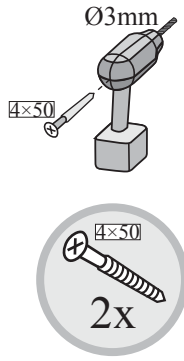
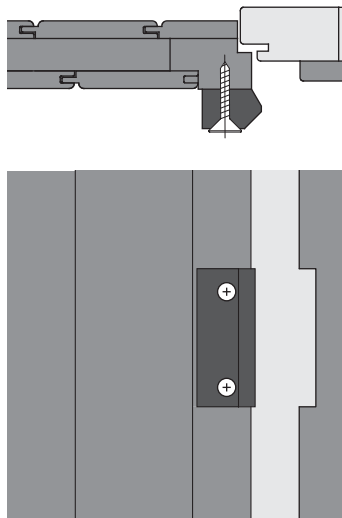

# 2.

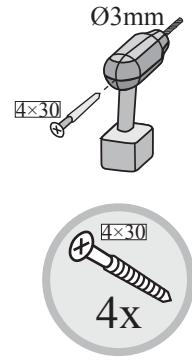
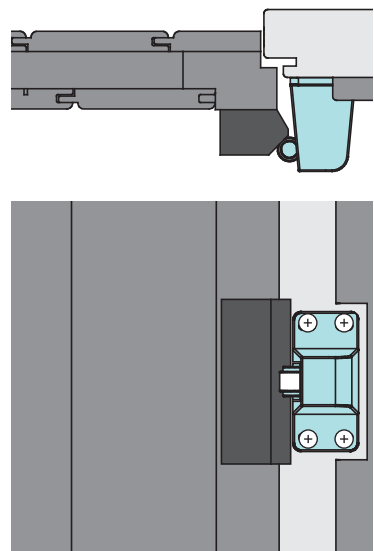

# 3.

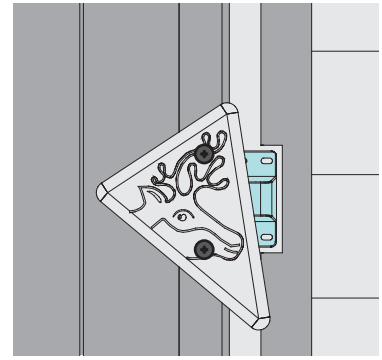
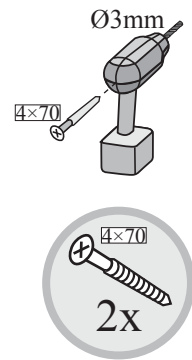
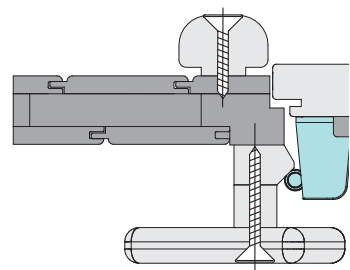
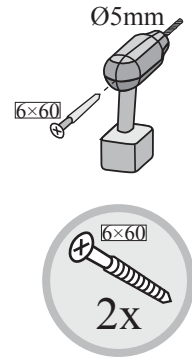
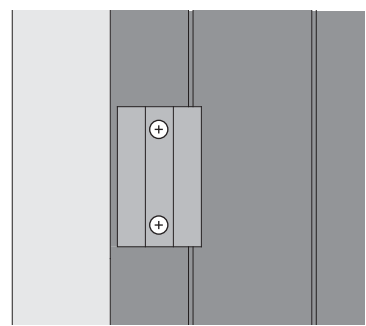
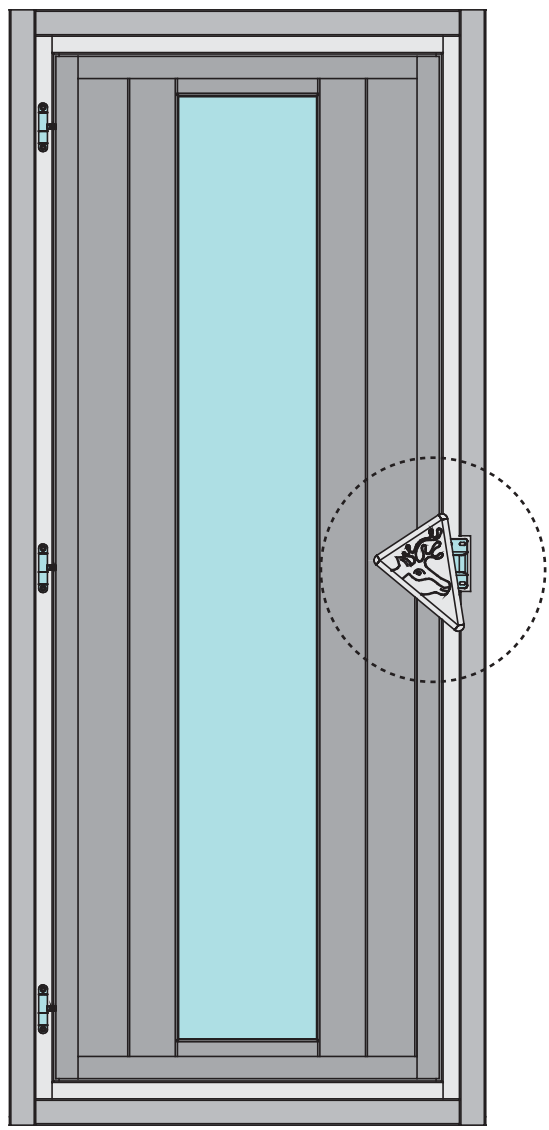

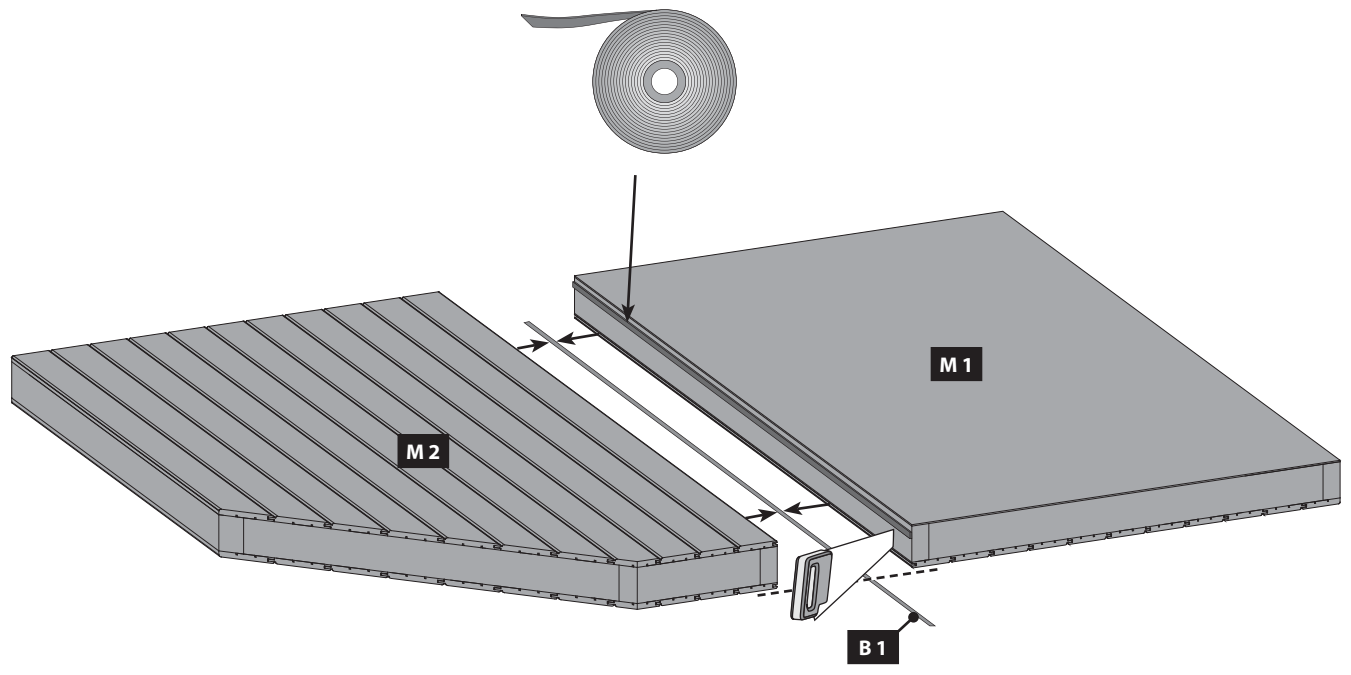
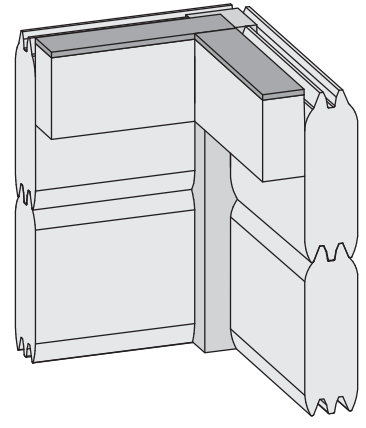
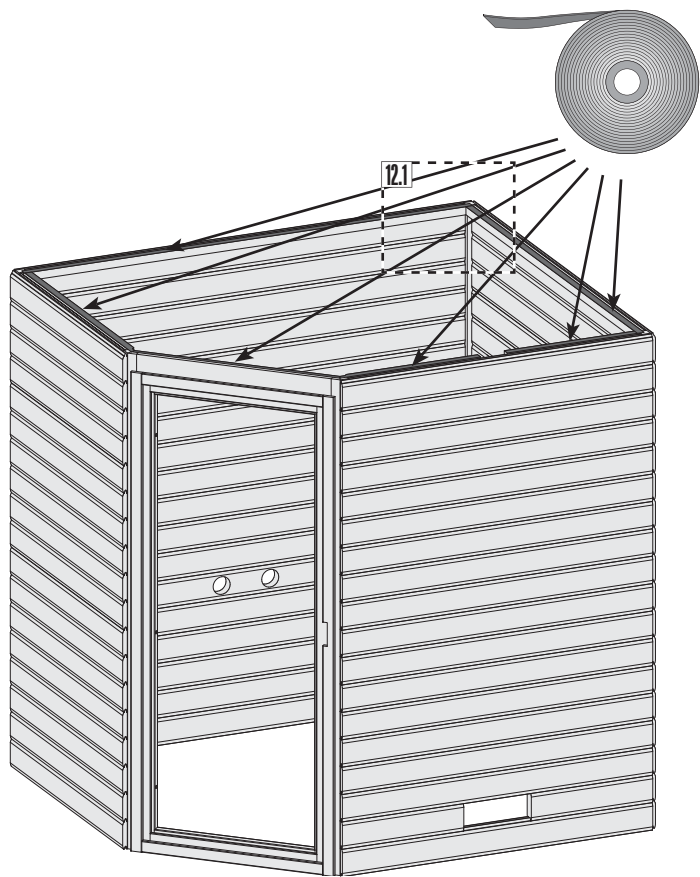

13

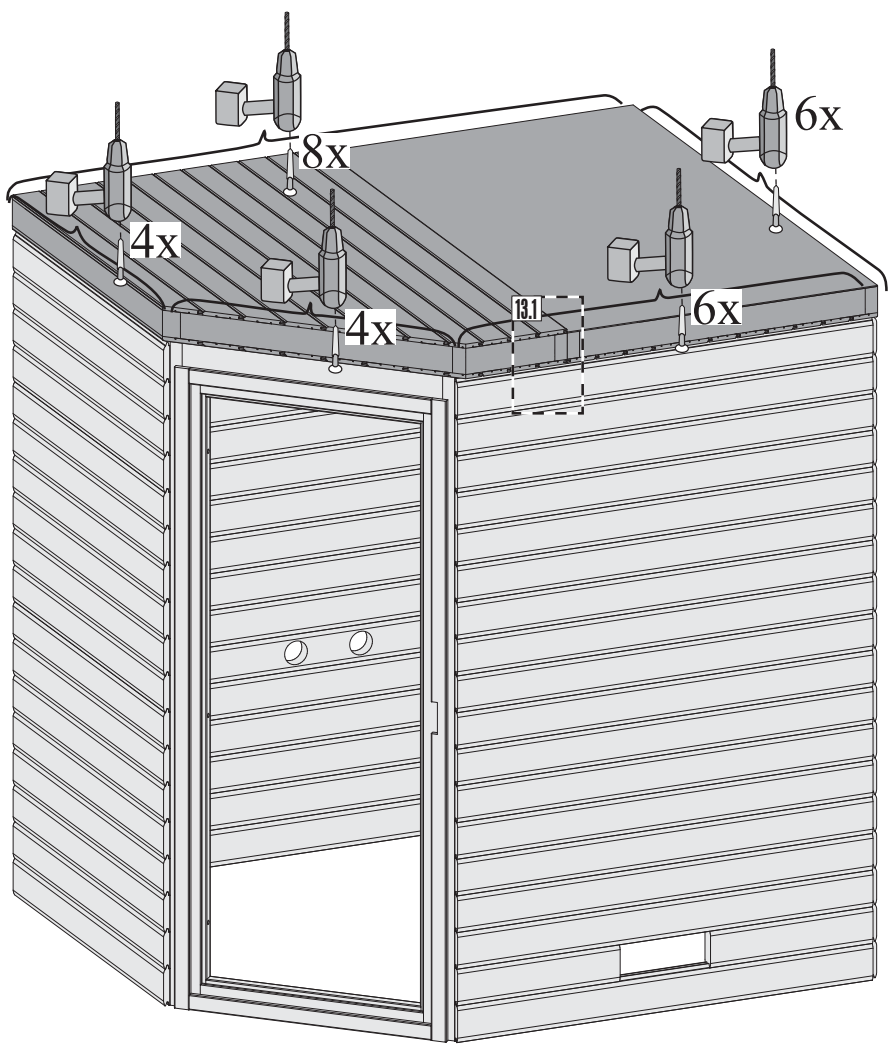

13.1

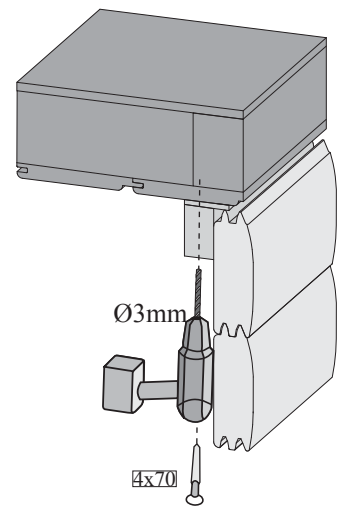

14

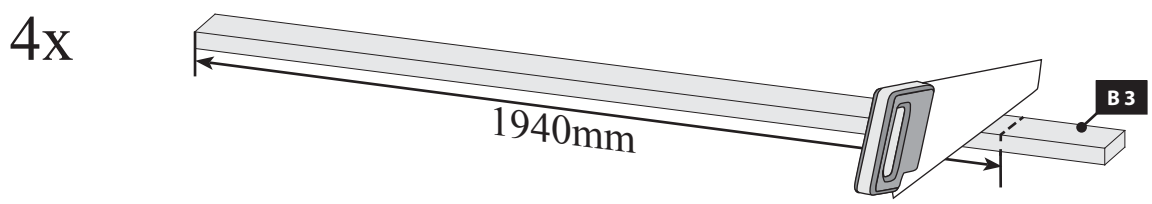

15

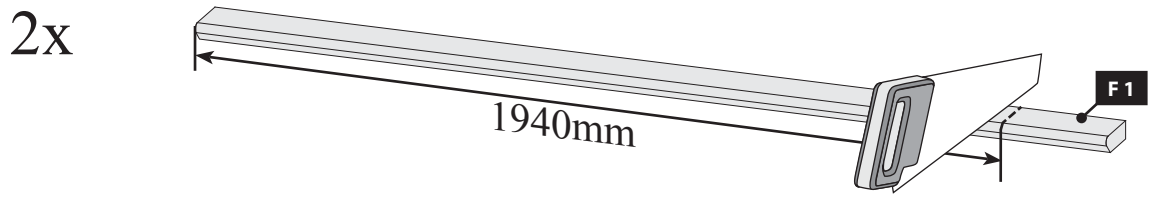

16

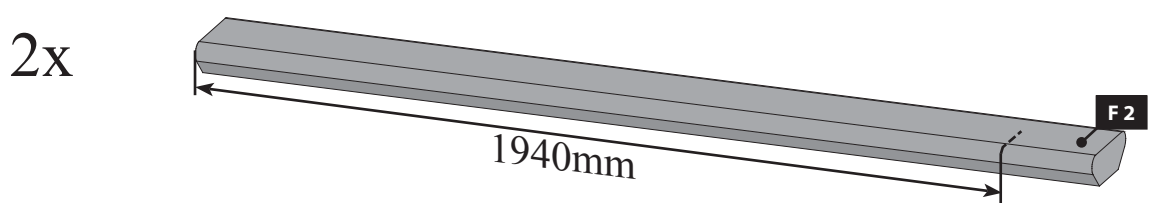

17

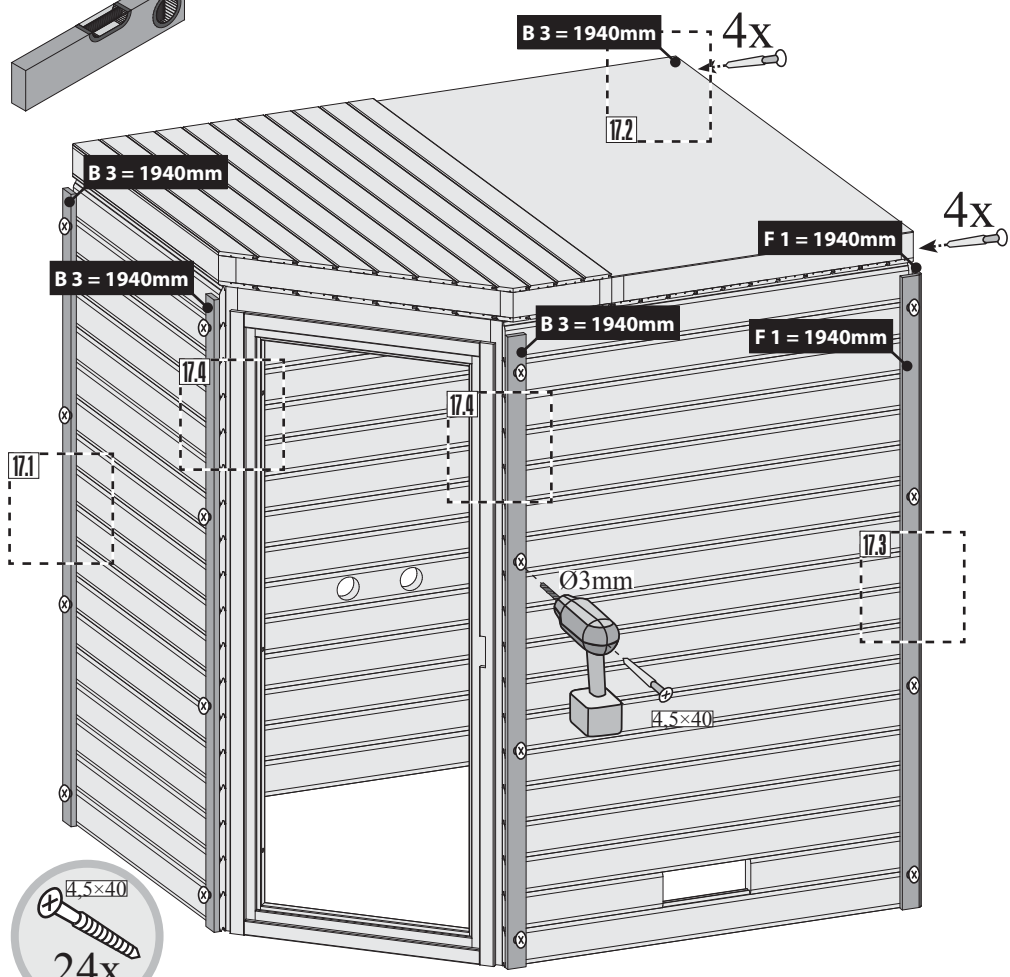
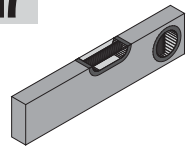

17.1

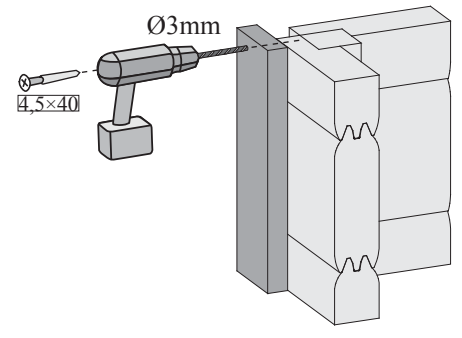

17.2

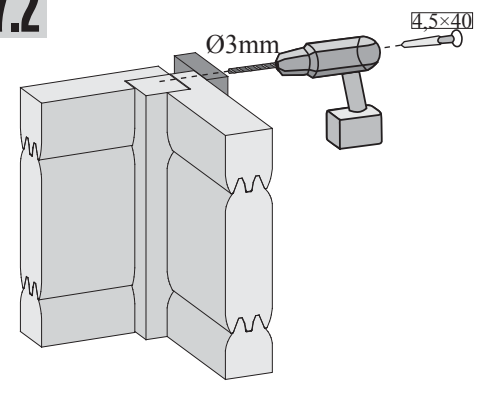

17.3

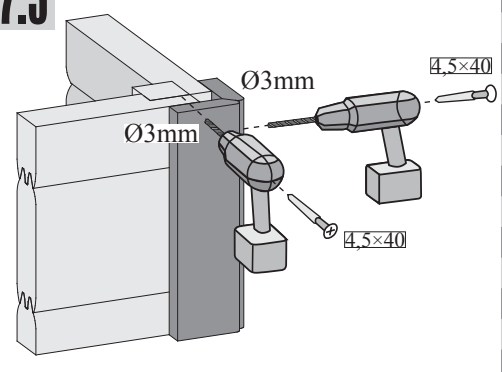

17.4

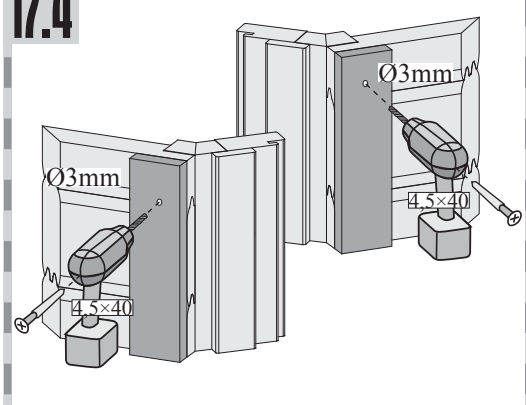

18

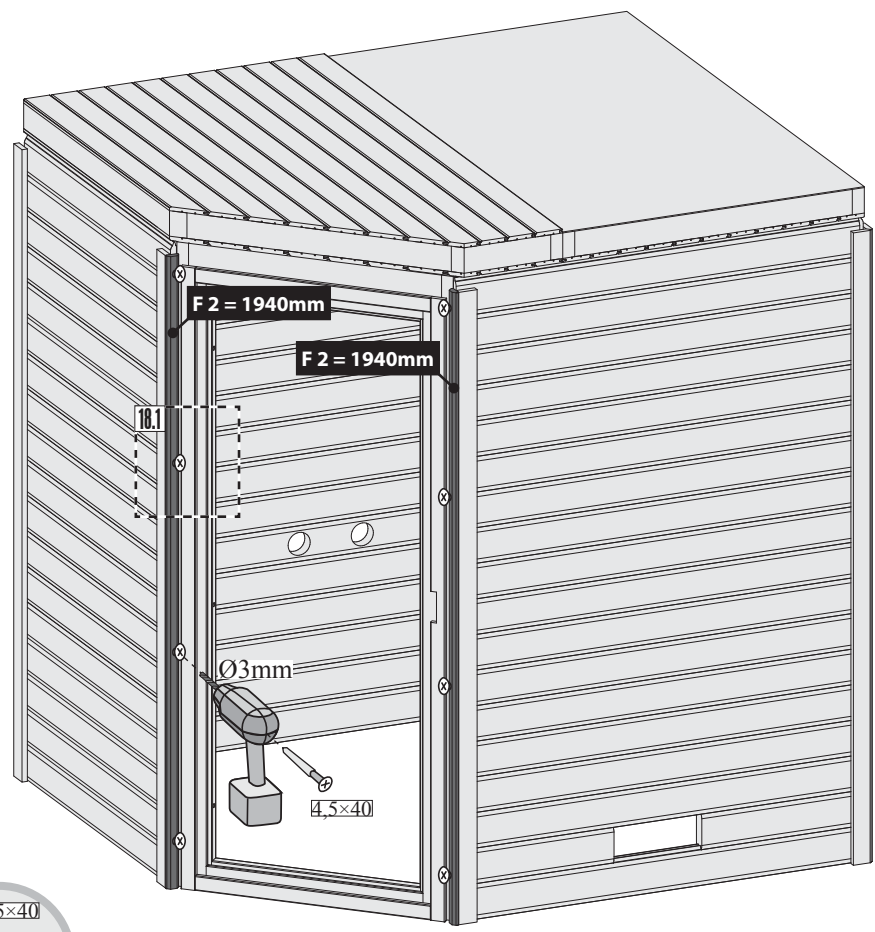

18.1

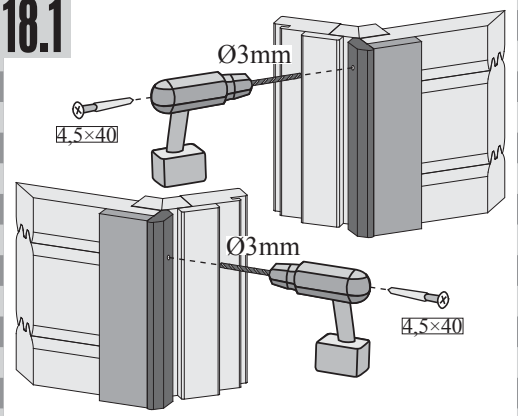

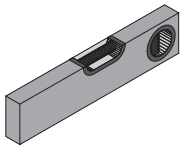

-  Bündig!
-  Flush!
-  Affleurement!
-  Gelijk!
-  I flugt!
-  Aras!
-  Combacia!
-  Stejný!
-  Splakovanje!

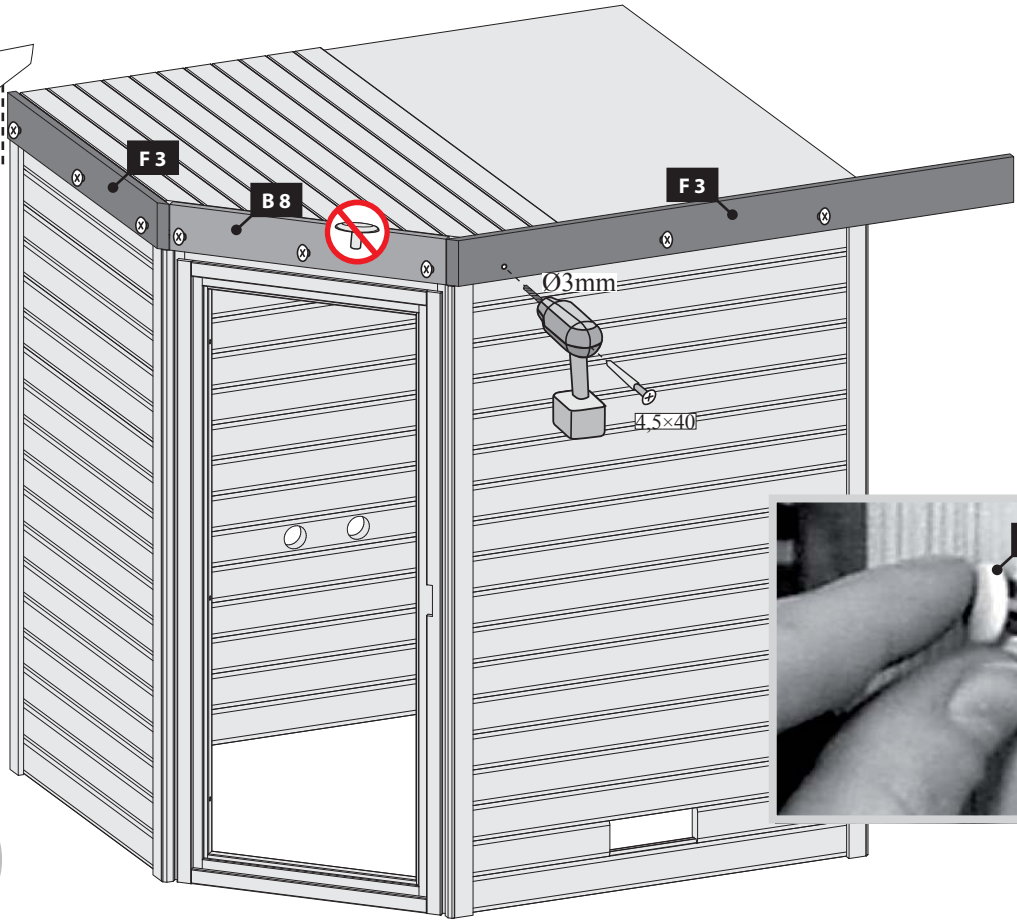

19.1

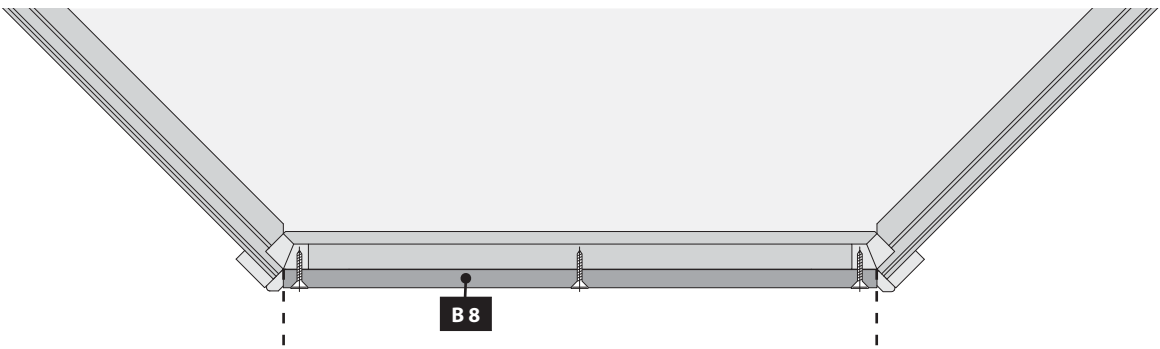

19.2

-  Bündig!
-  Flush!
-  Affleurement!
-  Gelijk!
-  I flugt!
-  Aras!
-  Combacia!
-  Stejný!
-  Splakovanje!



-  Bündig!
-  Flush!
-  Affleurement!
-  Gelijk!
-  I flugt!
-  Aras!
-  Combacia!
-  Stejný!
-  Splakovanje!





-  Bündig!
-  Flush!
-  Affleurement!
-  Gelijk!
-  I flugt!
-  Aras!
-  Combacia!
-  Stejný!
-  Splakovanie!

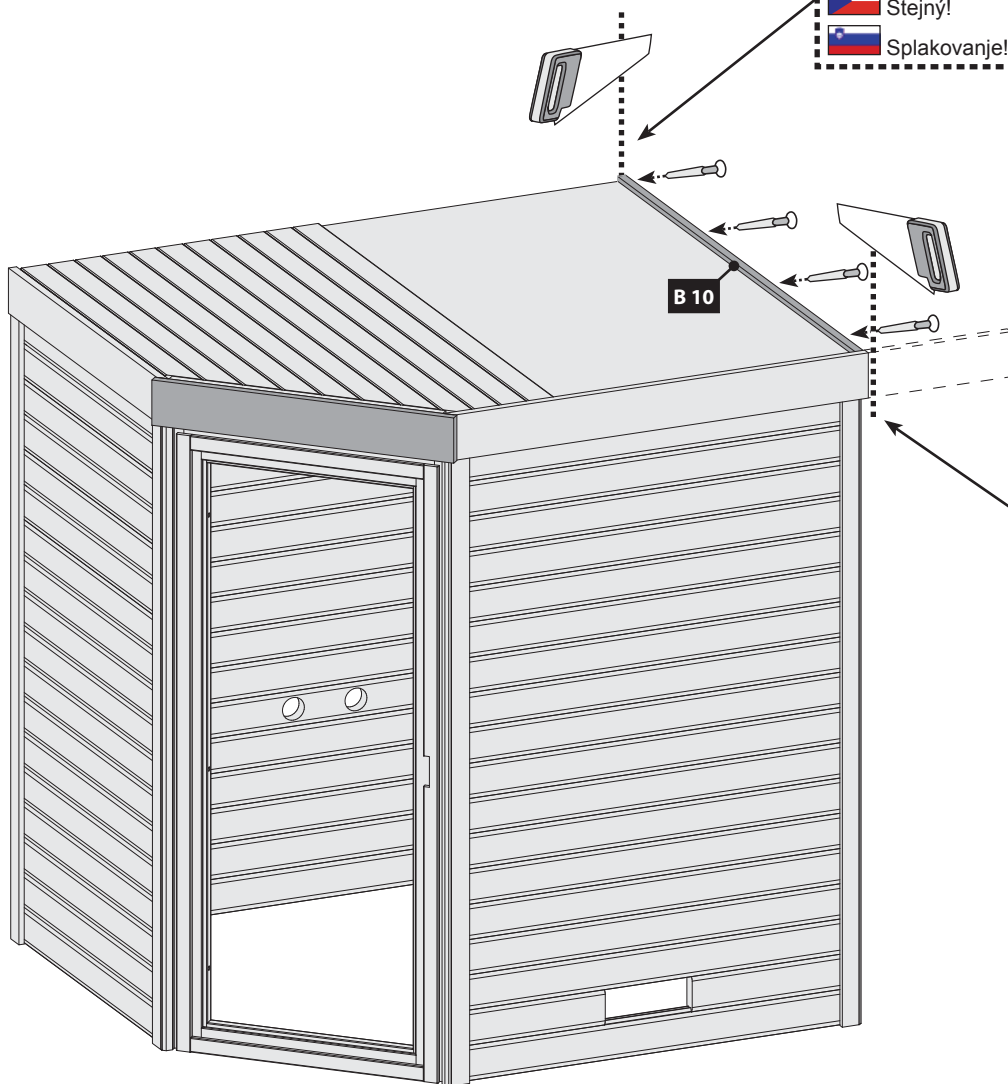

-  Bündig!
-  Flush!
-  Affleurement!
-  Gelijk!
-  I flugt!
-  Aras!
-  Combacia!
-  Stejný!
-  Splakovanie!

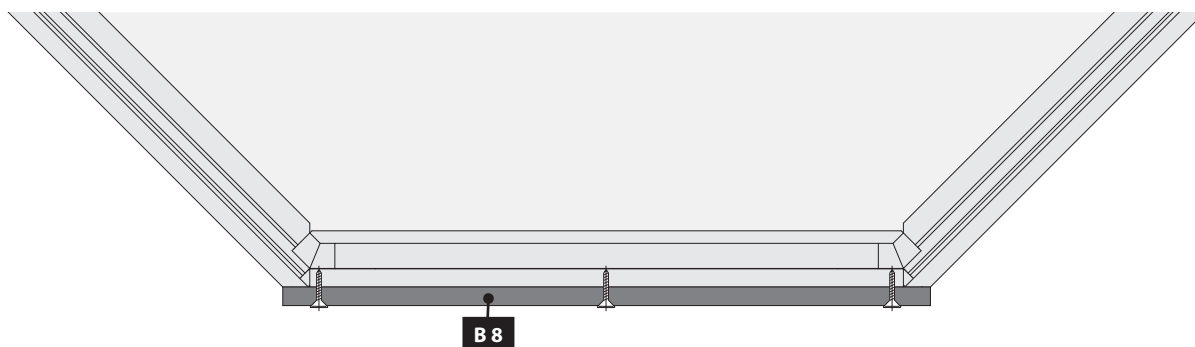

B 8

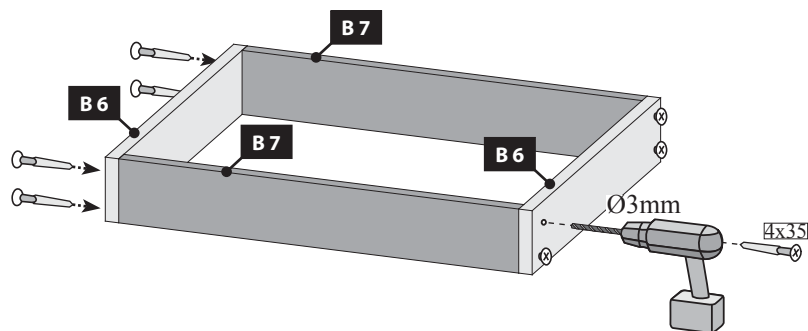
**21 2x****22 a**

-  Nur bei 9 kW-Ofen
-  Only 9 kW heater
-  Seulement 9 kW chauffe
-  Kun ved 9 kW ovn
-  Slechts 9 kW heater
-  Sólo calentador de 9 kW
-  Solo riscaldamento 9 kW
-  Pouze topné těleso 9 kW
-  Samo s pečjo 9 kW

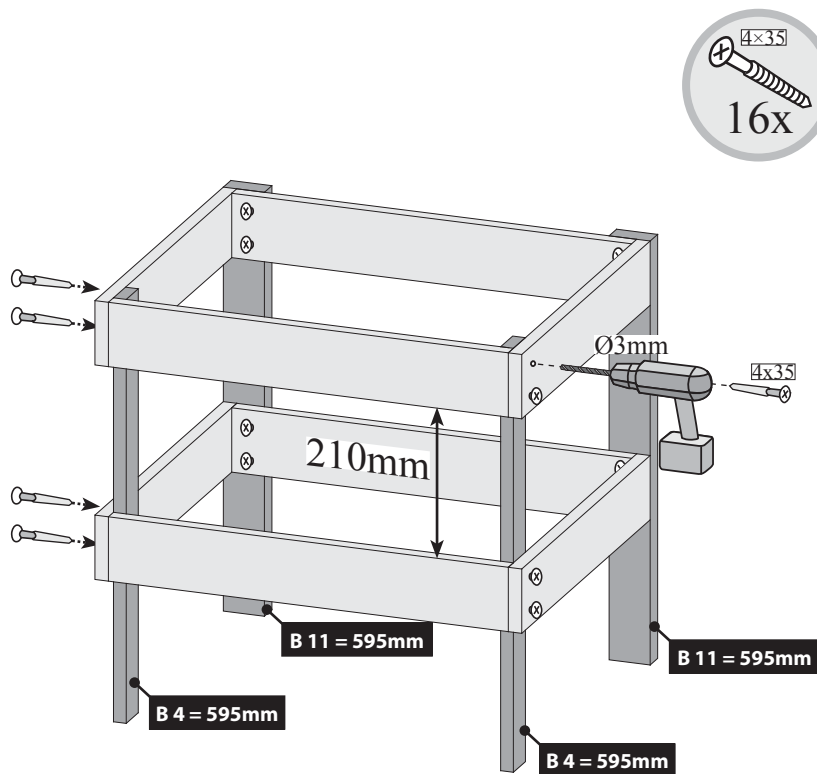
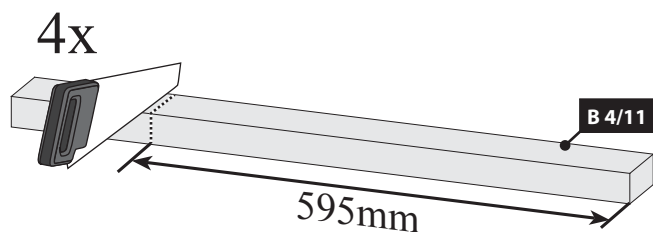
**22 b**

-  Bei allen anderen Öfen
-  For all other furnaces
-  Pour tous les autres fours
-  Kun ved 9 kW ovn
-  Voor alle andere ovens
-  Para todos los otros hornos
-  Per tutti gli altri tipi di forni
-  U všech ostatních pecích
-  Za vse druge pečji

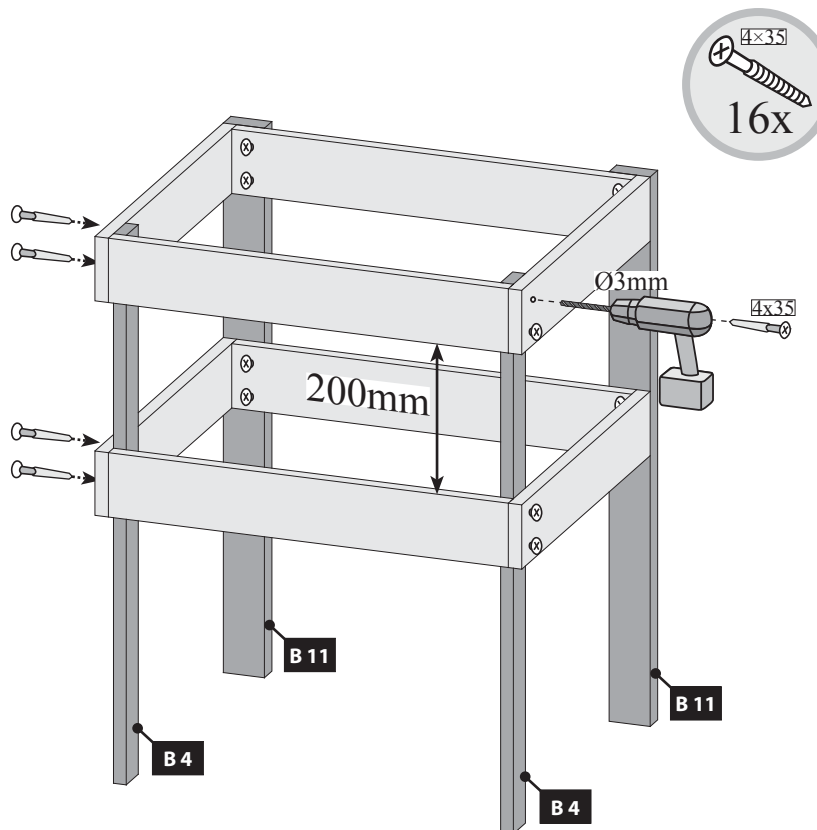

23

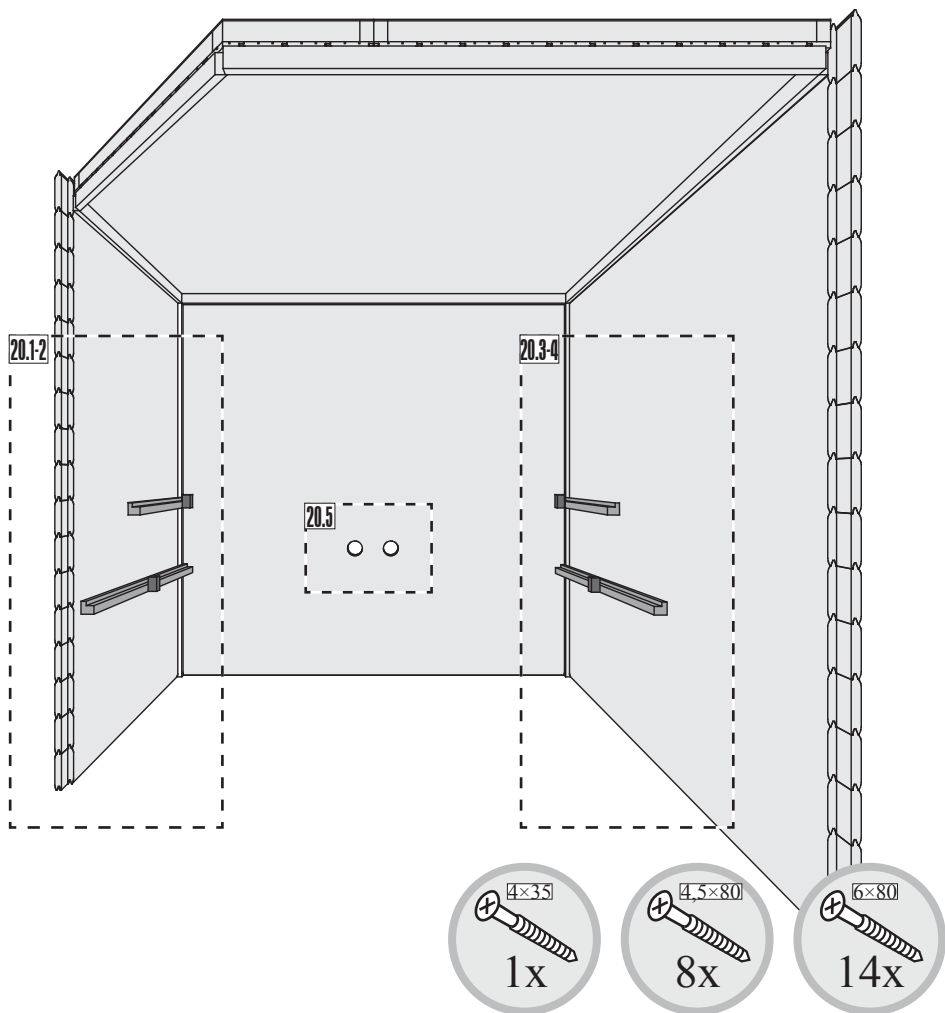

23.1

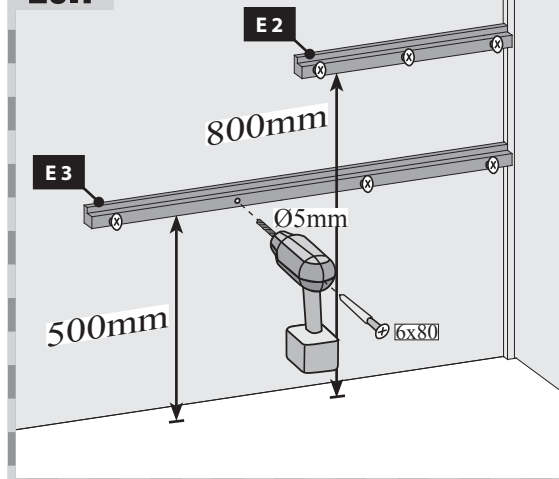

23.2

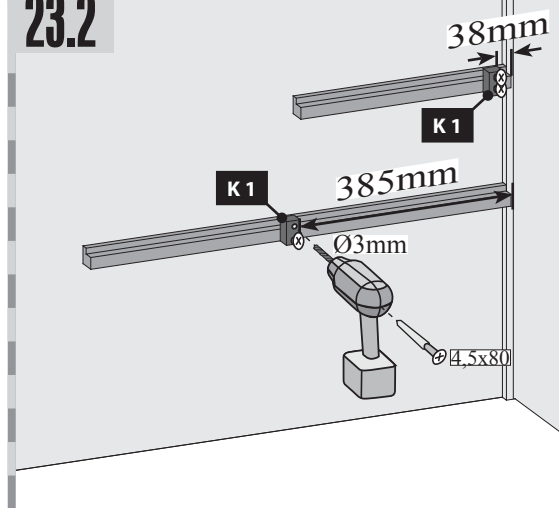

23.5

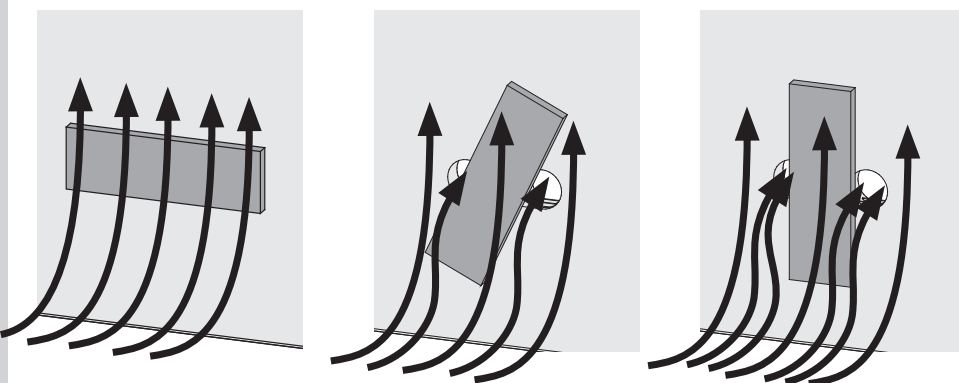
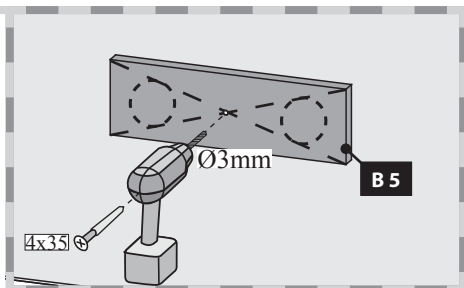

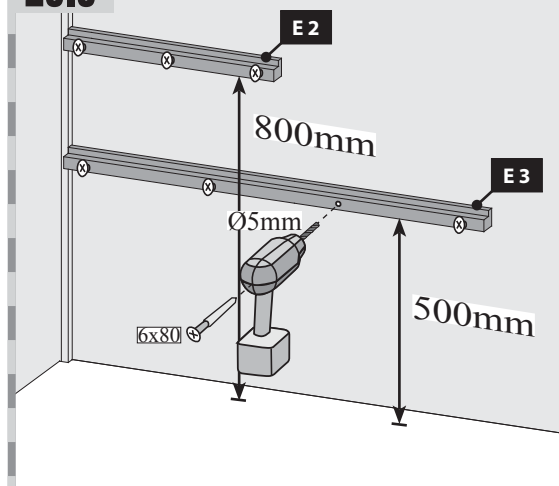

23.3



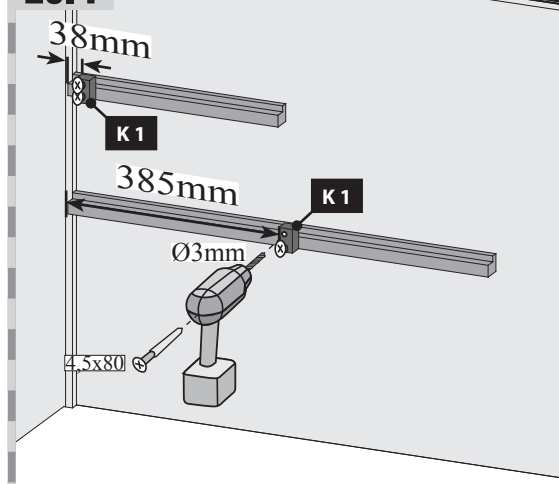

23.4





 Hier ist die Funktionsweise des Brettes abgebildet. Regeln Sie damit die Abluft nach Ihren eigenen Wünschen.

 Ceci représente le mode de fonctionnement de la planche. Avec elle, réglez l'écoulement de l'air selon vos désirs.

 This figure shows the functional principle of the board. Regulate the exhaust air according to your own wishes.

 Hier is de werking van het plankje afgebeeld. Regel daarmee de luchtafvoer naar eigen wens.

 Aquí está representada la forma de funcionamiento de la tabla. Regule con ello el aire de salida según sus propios deseos.

 Viene illustrato il principio di funzionamento della tavoletta di regolazione della ventilazione. Con essa si può regolare a piacere la ventilazione.

 Zde je zobrazená funkce desky. Regulujte s ní odsávací vzduch dle Vašeho přání.

 Tukaj si lahko ogledate delovanje plošče. Z njo lahko uravnavate izpušni zrak po lastnih željah.

24 2x

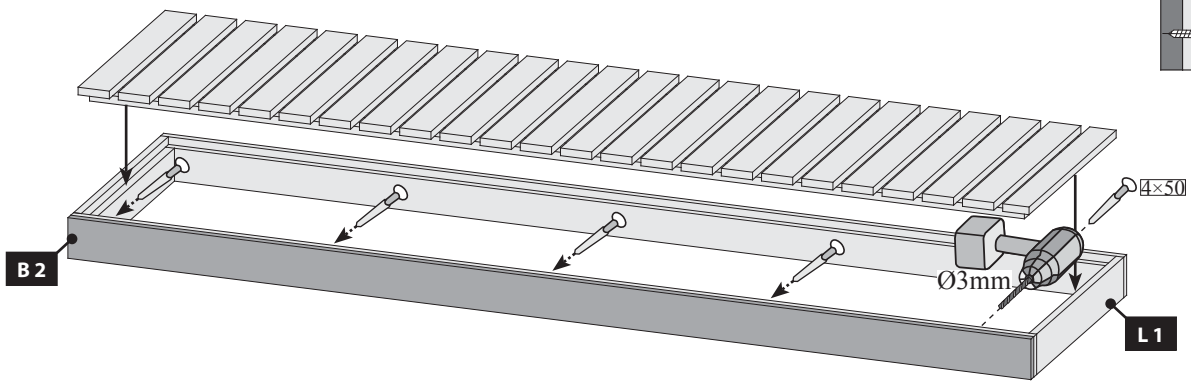
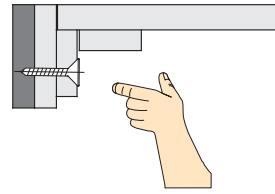

25

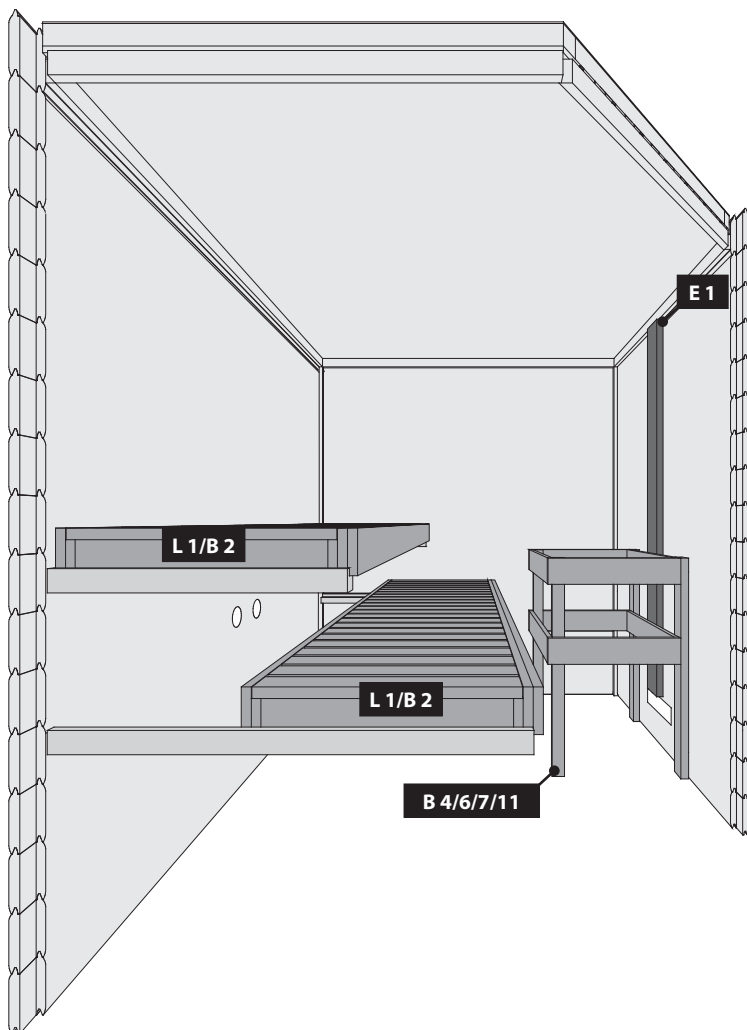
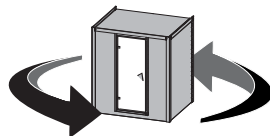

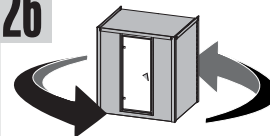

26

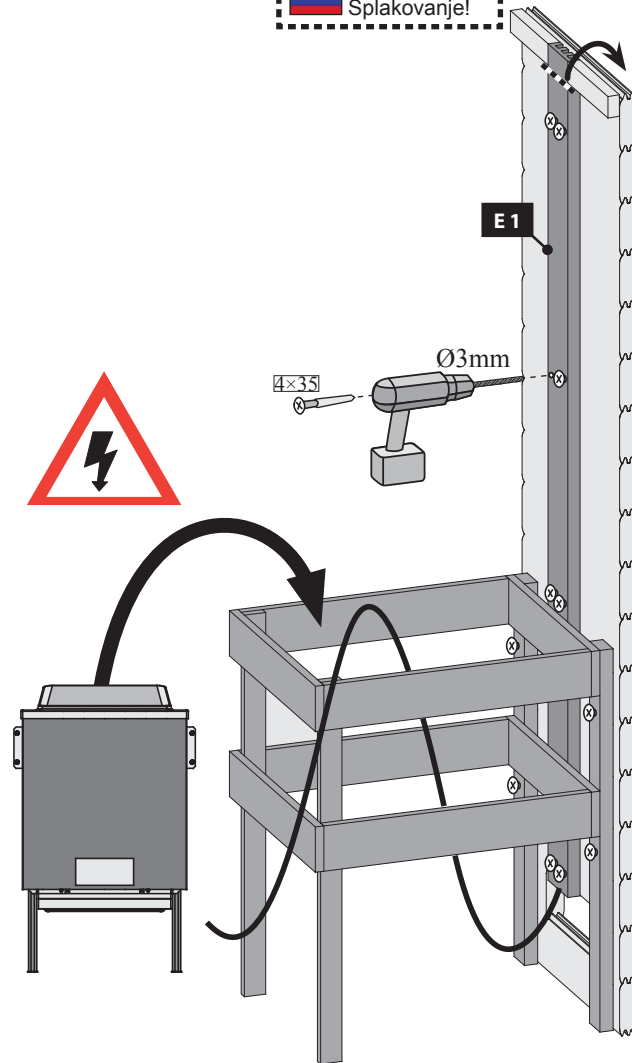
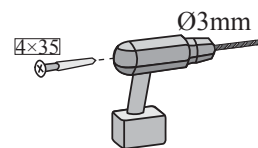
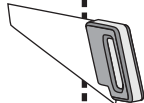

-  Bündig!
-  Flush!
-  Affleurement!
-  Gelijk!
-  I flugt!
-  Aras!
-  Combacia!
-  Stejný!
-  Splakovanie!



 Exemplarische Kabelverlegung

 Voorbeeld van het leggen van kabels

 Esempi di posa di cavi

 Exemplary cable laying

 Eksempel på kabellægning

 Příkladné pokládání kabelů

 Exemple de pose de câbles

 Tendido de cables ejemplar

 Vzorčno polaganje kablov

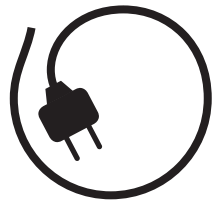

 Lampe

 Lamp

 Lampe

 Lampe

 Lamp

 Lámpara

 Lampada

 Lampy

 Svetilka



 380 V

 Fühler Ofen

 Oven sensor

 Sonde du four

 Ovnprobe

 Ovensonde

 Sonda del horno

 Sonda del forno

 Sonda do trouby

 Sonda v pečici

 Steuergerät

 Control unit

 Unité de contrôle

 Kontrolenhed

 Besturingseenheid

 Unidad de control

 Unità di controllo

 Řídicí jednotka

 Nadzorna enota

 Ofen

 Oven

 Four

 Ovn

 Oven

 Horno

 Forno

 Trouba

 Pečica

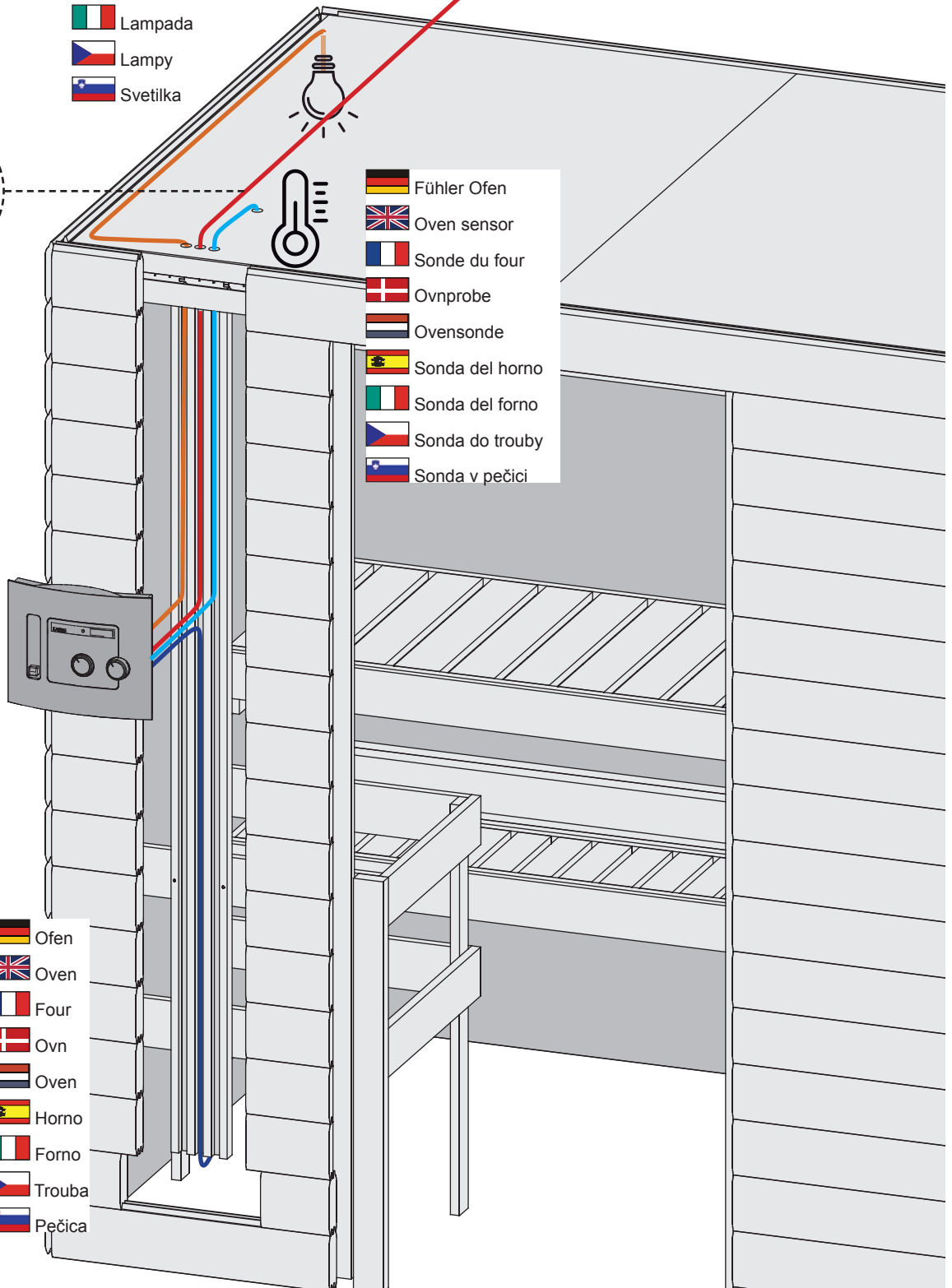



 Exemplarische Kabelverlegung

 Voorbeeld van het leggen van kabels

 Esempi di posa di cavi

 Exemplary cable laying

 Eksempel på kabellægning

 Příkladné pokládání kabelů

 Exemple de pose de câbles

 Tendido de cables ejemplar

 Vzorčno polaganje kablov

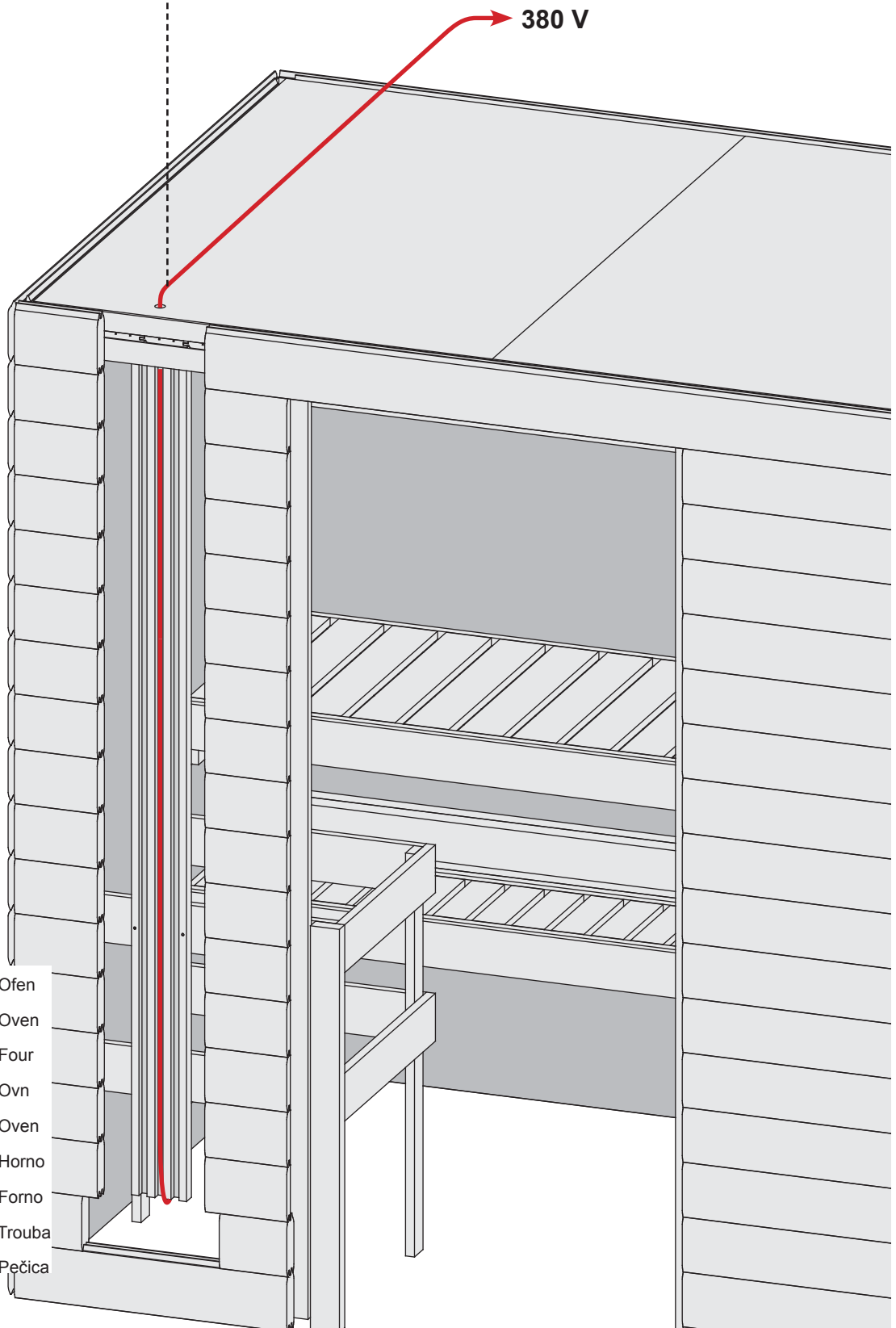
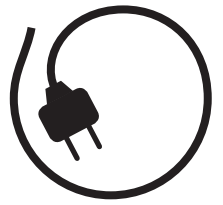

-  Ofen
-  Oven
-  Four
-  Ovn
-  Oven
-  Horno
-  Forno
-  Trouba
-  Pečica