

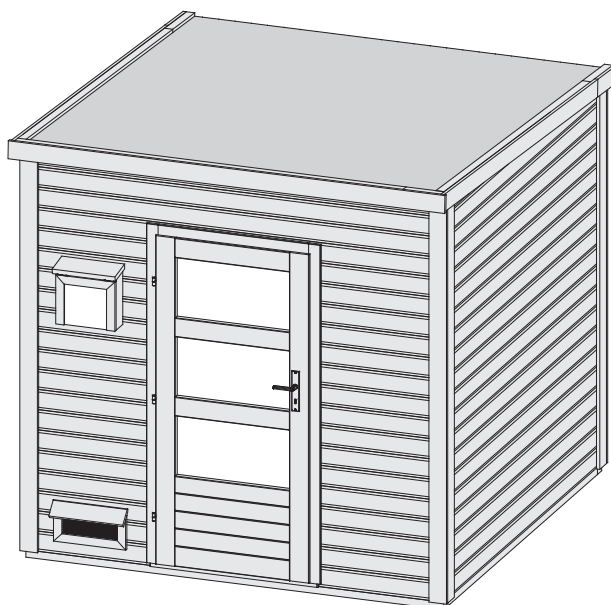

27306

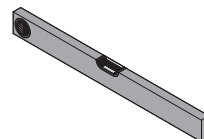

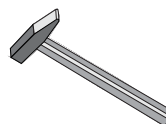



-  **Aufbauanleitung**
-  **Building Instructions**
-  **notice de montage**
-  **montagehandleiding**
-  **Montagevejledning**
-  **Instrucciones de construcción**
-  **Istruzioni per il montaggio**
-  **Montážní návod**











 Bitte bewahren Sie die Anleitung und den Garantieschein zur Seriennummer auf. Vernichten Sie diese erst nach Ablauf der Garantiezeit. Eventuelle Beanstandungen können mithilfe der Stückliste einfacher zugeordnet werden.





Beigelegte Dokumente:

- Informationsheft
- Garantieschein zur Seriennummer
- Typenschild inkl. Warnhinweise (Sauna)
- ggf. Zubehör-Anleitungen in externen Paketen

- \*  Nicht im Lieferumfang enthalten  
 Not included  
 Non comprises dans la livraison  
 Niet bijgeleverd



-  No forman parte del suministro  
 Non incluso  
 V ceně není zahrnuto  
 Ikke inkluderet

- 1  Länge muss ermittelt und zugesägt werden  
 Length must be determined and sawn  
 La longueur doit être déterminée et sciée  
 De lengte moet worden bepaald en worden gezaagd

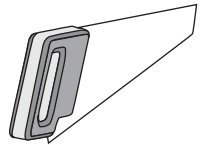
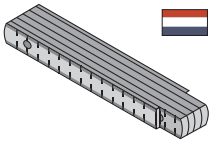
-  La longitud debe ser determinada y aserrada  
 La lunghezza deve essere determinata e segata  
 Délka musí být určena a rozřezána  
 Længden skal bestemmes og saves



- 2  Nicht gebraucht  
 Not needed  
 Pas nécessaire  
 Niet nodig



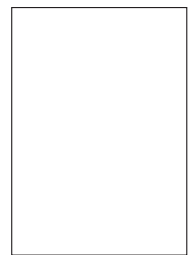

-  No es necesario  
 Non necessario  
 Není nutná

- 3  mit Zubehör!  
 met toebehoren!  
 with accessories!  
 avec accessoires!





-  con accesorios!  
 con accessori!  
 s příslušenstvím!  
 z dodatki!



- 4  Fixiert vorübergehend  
 tijdelijk vast  
 Fixed temporarily  
 temporairement fixe

-  temporalmente fijo  
 temporaneamente fisso  
 dočasně pevný  
 Zčasno pritrjeno

- 5  Bestand vom Haus  
 Inventaris van het huis  
 Inventory of the house  
 Inventaire de la maison

-  Inventario de la casa  
 Inventario della casa  
 Inventář domu  
 Inventar hiše

Werkzeuge / Tools\*

X

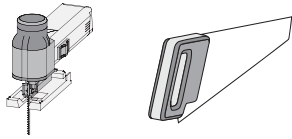

X

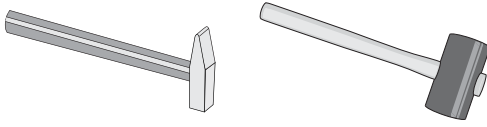

X

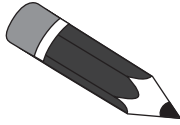

X

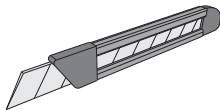
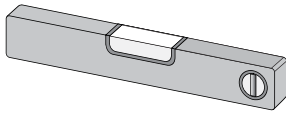

X

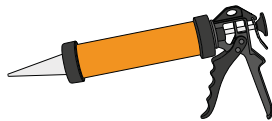
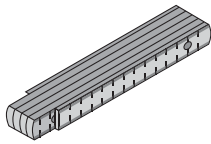

X

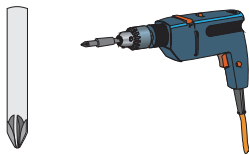

X

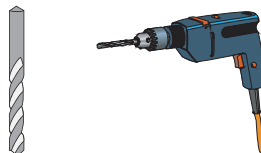

X

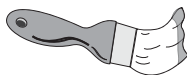

X





Technische Daten

In der Auftragsbestätigung bzw. Lieferschein ist der gekaufte Ofentyp bzw. das erworbene Steuergerät zu finden. Bitte entnehmen Sie die technischen Daten Ihrer Geräte der folgenden Auflistung

Gerät	Netzspannung	Wattage
<b>Öfen</b>		
9kW Ofen Bio	400V ~ 3N	9kW
9kW Ofen (Finnisch)	400V ~ 3N	9kW
9kW Ofen integr. Steuerung	400V ~ 3N	9kW
4,5kW Ofen Bio	400V ~ 3N	4,5kW
4,5kW Ofen (Finnisch)	400V ~ 3N	4,5kW
4,5kW Ofen integr. Steuerung	400V ~ 3N	4,5kW
3,6kW Ofen Bio	230V ~ 1N	3,6kW
3,6kW Ofen (Finnisch)	230V ~ 1N	3,6kW
3,6kW Ofen integr. Steuerung	230V ~ 1N	3,6kW
<b>Steuergeräte</b>		
externe Steuerung Easy Bio	400V ~ 3N	max. 10,8kW
externe Steuerung Plug&Play Bio	240V ~ 3N	max. 10,8kW
externe Steuerung (Finnisch)	400V ~ 3N	max. 10,8kW
externe Steuerung Plug&Play (Finnisch)	240V ~ 3N	max. 10,8kW
Multisteuergerät	400V ~ 3N	max. 10,5kW
externe Steuerung Classic Bio	400V ~ 3N	max. 9kW
externe Steuerung Classic (Finnisch)	400V ~ 3N	max. 9kW
externe Steuerung Premium Bio	400V ~ 3N	max. 12kW
externe Steuerung Premium (Finnisch)	400V ~ 3N	max. 9kW

 Vergleichen Sie zuerst die Material-liste mit Ihrem Paketinhalt! Bitte haben Sie Verständnis, dass Beanstandungen nur im nicht aufgebauten Zustand bearbeitet werden können!

 Vergelijk eerst de lijst van materialen met de inhoud van uw pakket! Reclamaties kunnen alleen in behandeling worden genomen zolang de onderdelen nog niet zijn gemonteerd!

 Confrontate questa distinta materiali prima con il contenuto del pacchetto! Vi preghiamo di comprendere che eventuali reclami possono essere accolti solo prima del montaggio!

 First compare the list of materials with your package contents! Please understand that complaints can be processed in the non-built status only!

 Start med at kontrollere materialelisten med indholdet af den leverede pakke! Vi gør venligst opmærksom på at reklamationer kun kan behandles for materialer som ikke er blevet bearbejdet!

 Nejprve překontrolujte obsah balení podle materiálového listu! Mějte pochopení pro to, že případnou reklamaci se můžeme zabývat pouze tehdy, když díly nebudou smontované! Za pomoci tohoto seznamu můžete jednotlivé díly přiřadit k montážnímu návodu.

 Commencez par comparer la liste du matériel avec le contenu de votre paquet! Sachez que nous traitons uniquement les réclamations concernant le matériel à l'état non monté!

 En primer lugar, compare la lista de material con el contenido del paquete. Rogamos entienda que las reclamaciones sólo pueden ser tramitadas antes de montar el objeto!

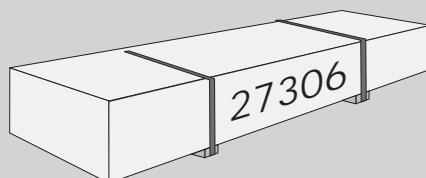

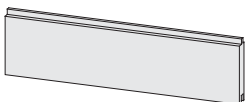
				
27 x U1	860 x 96 x 19 mm	ID 19003		
27 x U2	1600 x 96 x 19 mm	ID 73008		
25 x U3	2195 x 96 x 19 mm	ID 65729		

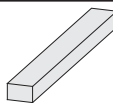
				
2 x B1	1920 x 20 x 3 mm	ID 20799		
2 x B2	800 x 45 x 18 mm	ID 24796		
1 x B3	910 x 45 x 18 mm	ID 35734		
5 x B4	2100 x 45 x 18 mm	ID 19547		
1 x B5	300 x 95 x 18 mm	ID 19130		
4 x B6	480 x 95 x 18 mm	ID 20930		
4 x B7	565 x 95 x 18 mm	ID 15498		
6 x B8	2193 x 95 x 18 mm	ID 70618		
10 x B9	2200 x 95 x 18 mm	ID 52334		
4 x B10	2350 x 95 x 18 mm	ID 29480		
1 x B11	2362 x 95 x 18 mm	ID 21243		
6 x B12	2124 x 38 x 28 mm	ID 26591		
2 x B13	800 x 58 x 28 mm	ID 15493		
4 x B14	60 x 36 x 36 mm	ID 5512		
4 x B15	2245 x 36 x 36 mm	ID 70492		
6 x B16	2345 x 60 x 40 mm	ID 39752		
2 x B17	2156 x 90 x 16 mm	ID 71514		

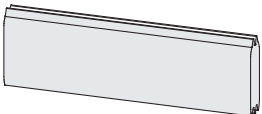
				
2 x W1	171 x 121 x 38 mm	ID 26597		
31 x W2	642 x 121 x 38 mm	ID 26596		
60 x W3	2195 x 121 x 38 mm	ID 70501		

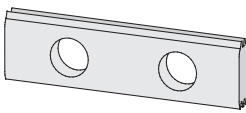
				
1 x W4	2195 x 121 x 38 mm	ID 4164		

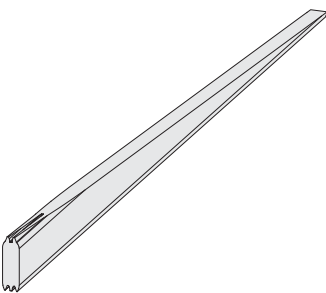
				
1 x G1	2195 x 121 x 38 mm	ID 26592		
1 x G2	2195 x 121 x 38 mm	ID 26593		

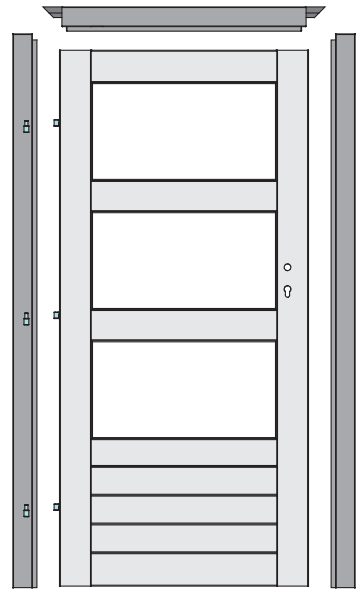
				
1 x D1	1820 x 980 x 40 mm	ID 83354		

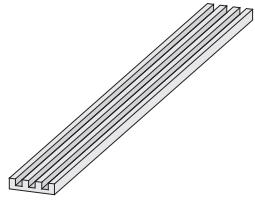
				
1 x E1	1823 x 140 x 26 mm	ID 26480		

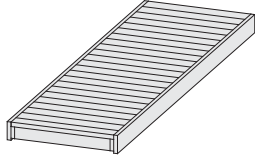
				
3 x L1	2156 x 550 x 95 mm	ID 52068		

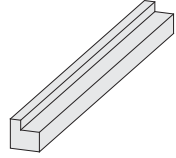
				
4 x L2	1120 x 45 x 45 mm	ID 70616		

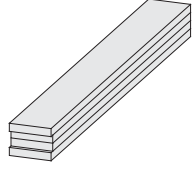
				
1 x L3	840 x 95 x 72 mm	ID 70625		

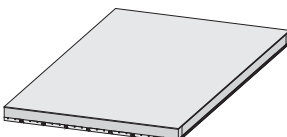
				
1 x N1	2189 x 349 x 57 mm	ID 21482		
2 x N2	2189 x 918 x 57 mm	ID 5983		

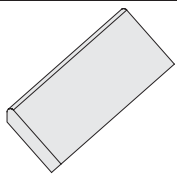

2 x M1 | 400 x 95 x 18 mm | ID 27167

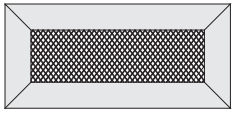

2 x F1 | 390 x 180 x 18 mm | ID 86726

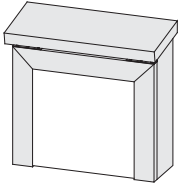

1 x F2 | 340 x 318 x 157 mm | ID 63452

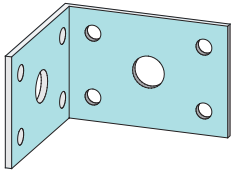

4 x | | ID 21292

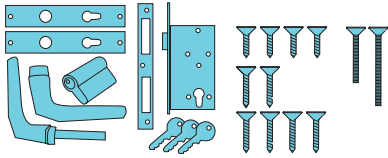

1 x | | ID 15979

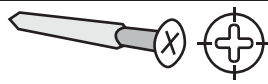

50 x	4 x 30 mm	ID 3686
130 x	4 x 35 mm	ID 3687
115 x	4 x 40 mm	ID 21925
140 x	4 x 50 mm	ID 3688
340 x	4 x 70 mm	ID 3689
20 x	4,5 x 80 mm	ID 9204
20 x	6 x 80 mm	ID 47558



5 x | 3 x 16mm | ID 46376



500 x | 2,5 x 50 mm | ID 5621

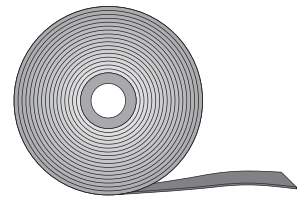

10m | | ID 14025



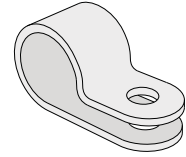

1 x | | ID 71504



1 x | | ID 50420

 Übersicht  
 Overview  
 enquête

 overzicht  
 undersøgelse  
 estudio

 sondaggio  
 přehled

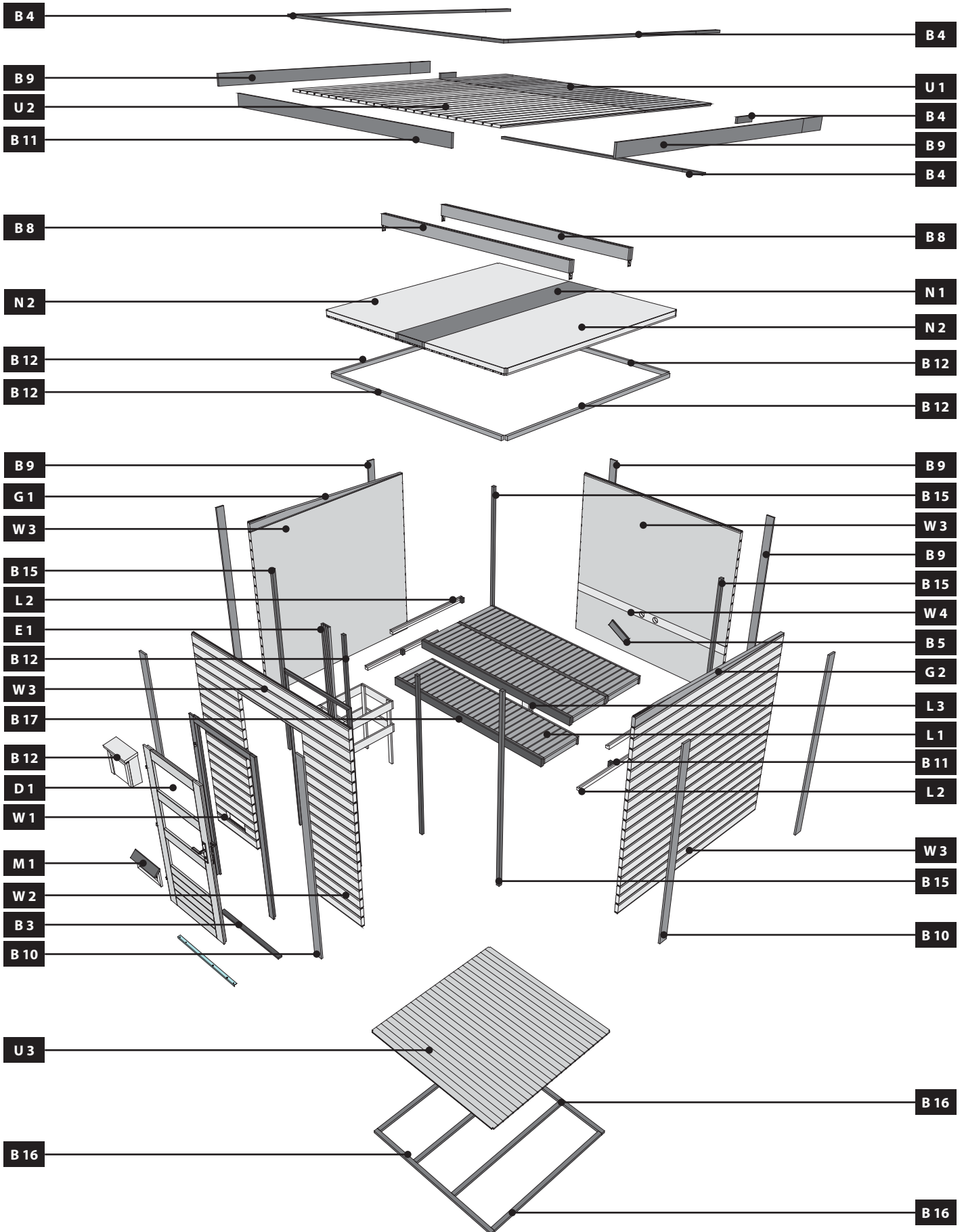

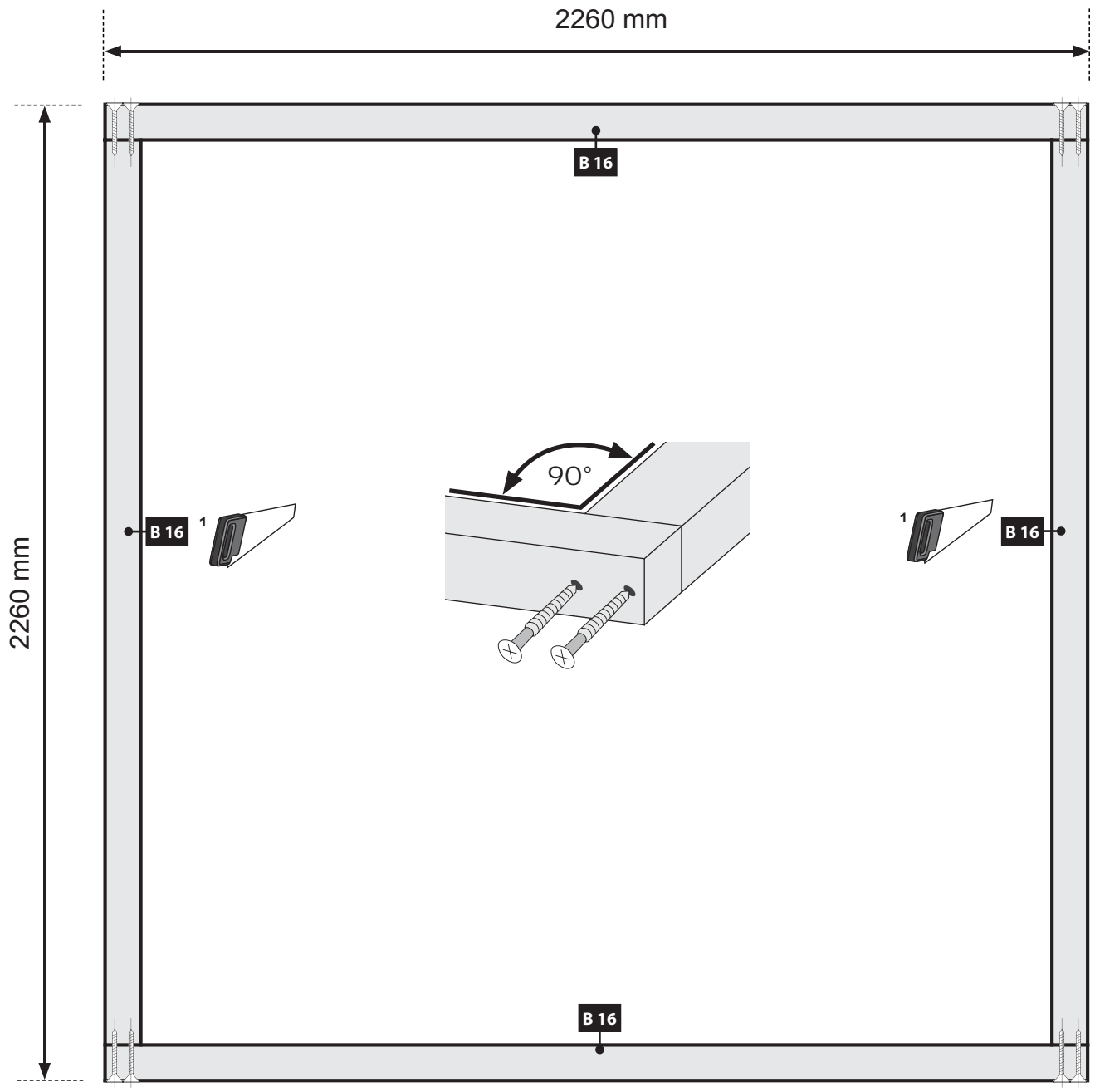
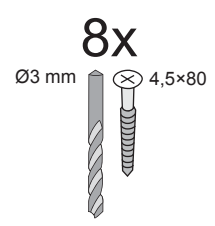
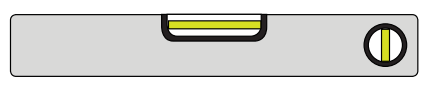

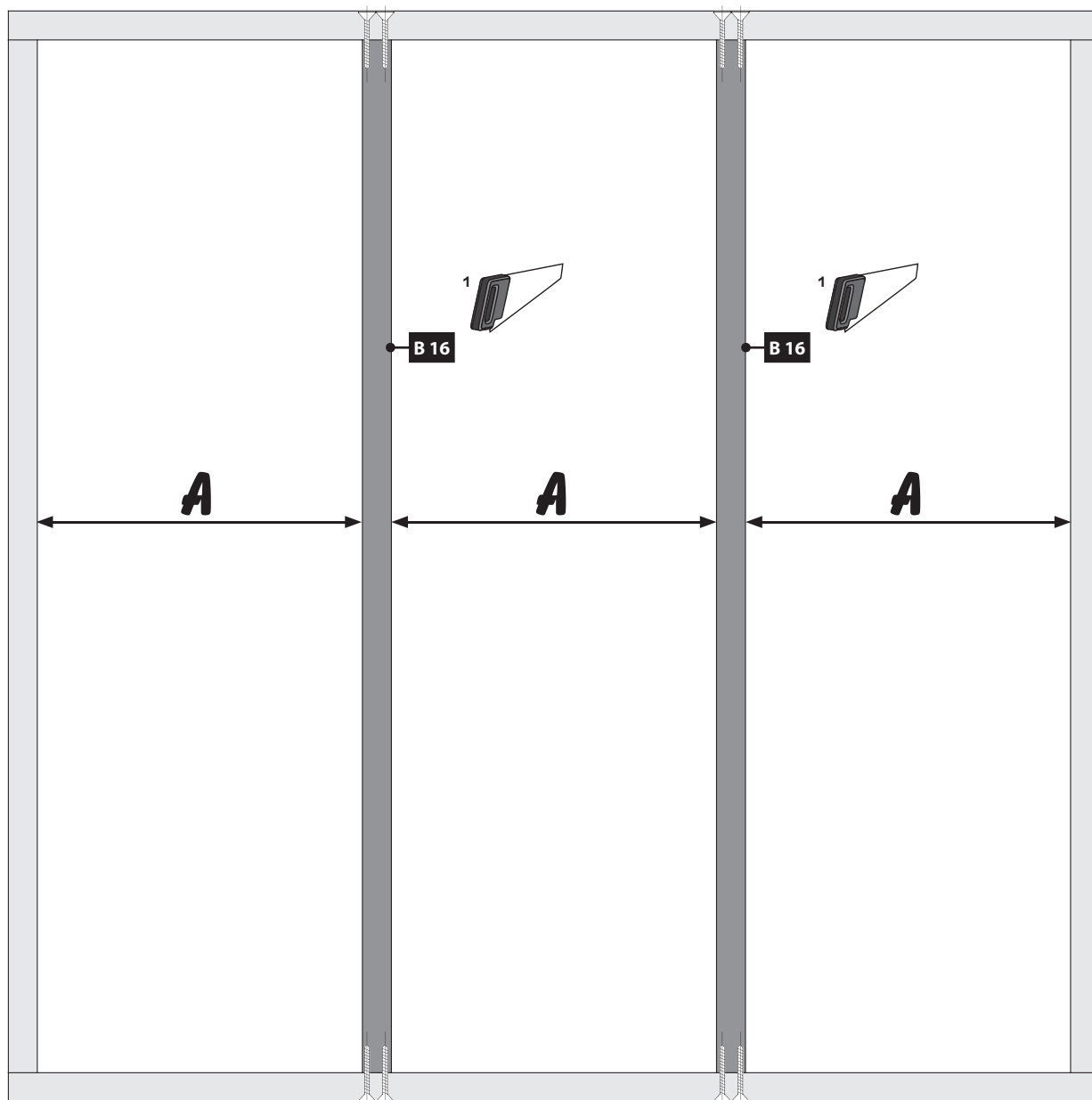
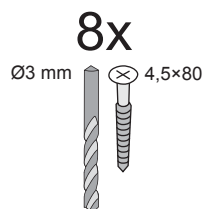

<sup>1</sup> Länge muss ermittelt und zugesägt werden

Length must be determined and sawn

La longueur doit être déterminée et sciée

De lengte moet worden bepaald en worden gezaagd

La longitud debe ser determinada y aserrada

La lunghezza deve essere determinata e segata

Délka musí být určena a rozřezána

Længden skal bestemmes og savnes

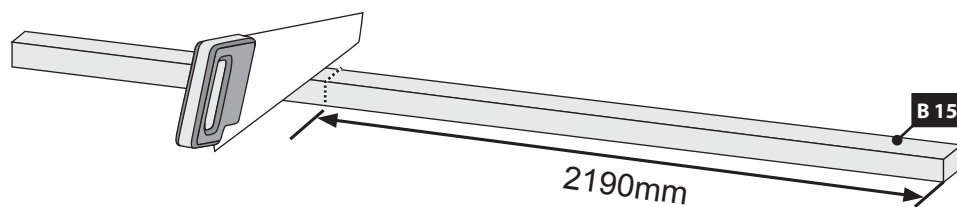



04 2x

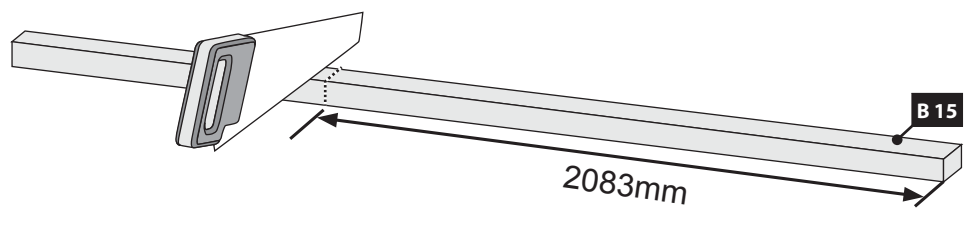

05

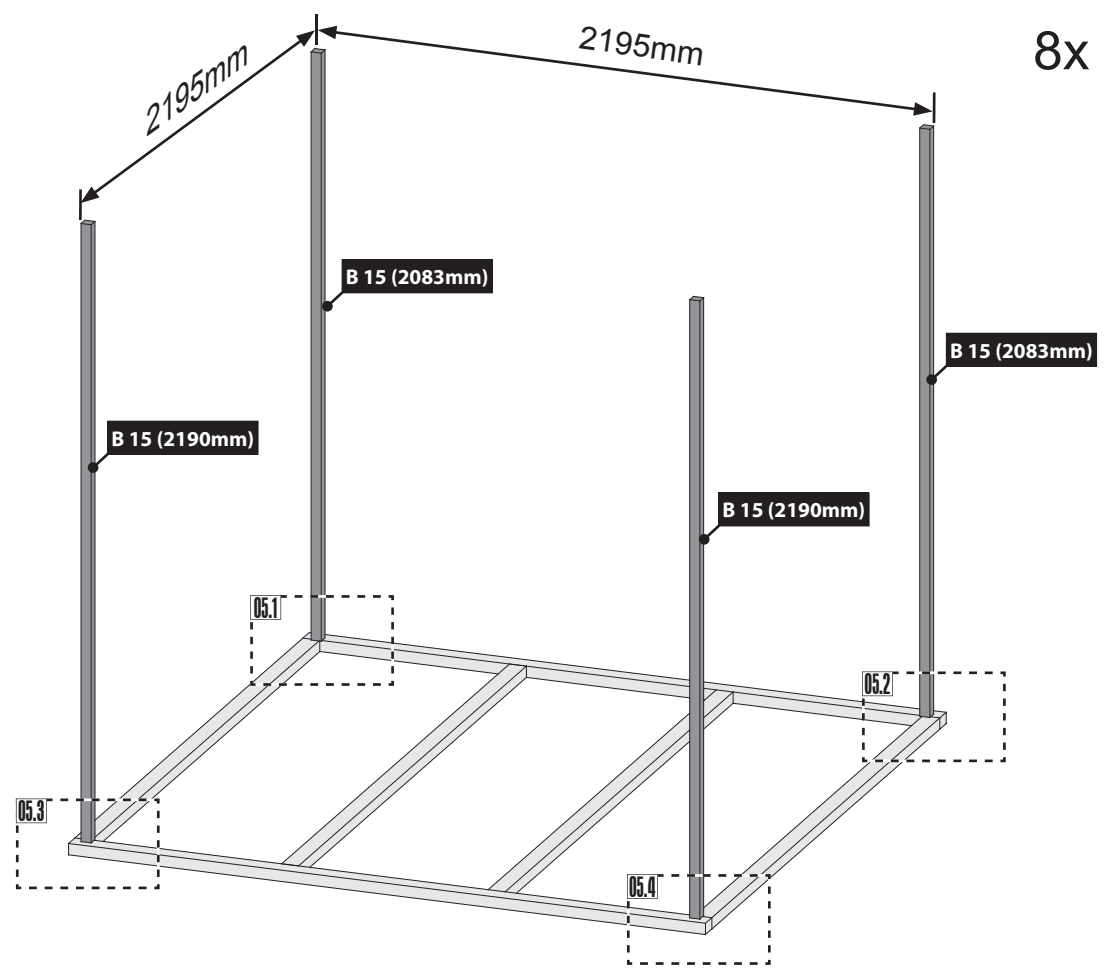
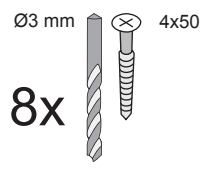
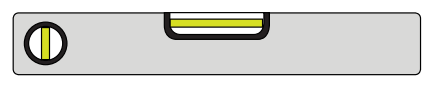

05.1

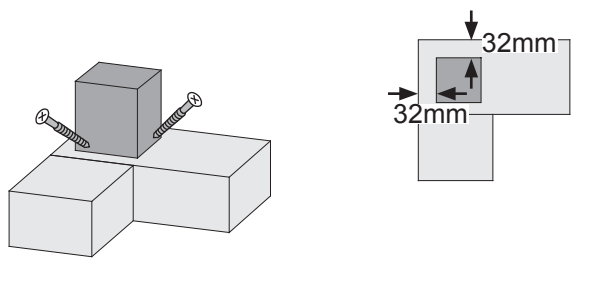

05.2

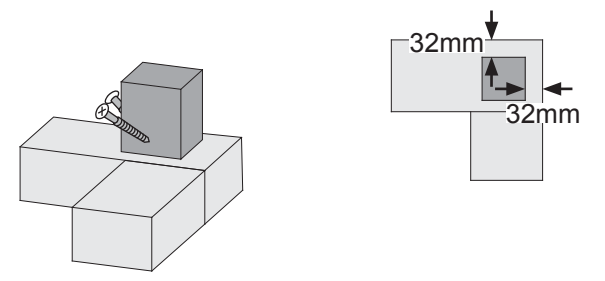



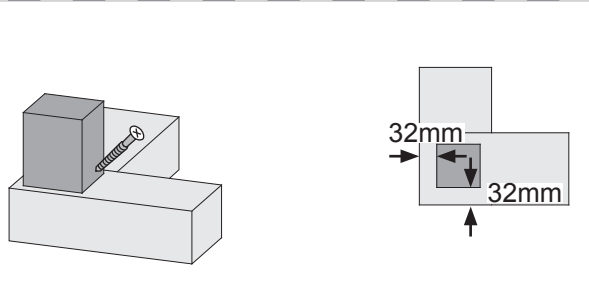

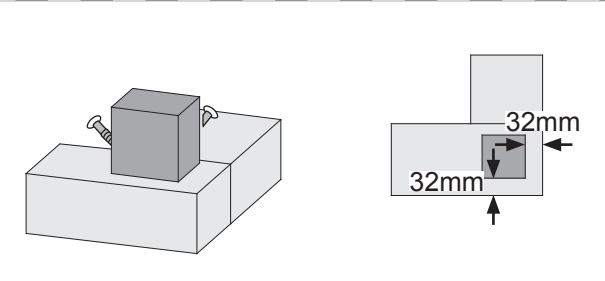

05.3





05.4



 Leim! Achten Sie auf die gleiche Höhe  
 Glue! Look for the same height  
 Colle! Faites attention à la même hauteur

 Lijm! Besteed aandacht aan de dezelfde hoogte  
 Pegamento! Prestar atención a la misma altura  
 Colla! Prestare attenzione alla stessa altezza

 Klíž! Dávejte pozor na stejnou výšku  
 Lim! Vær opmærksom på samme højde

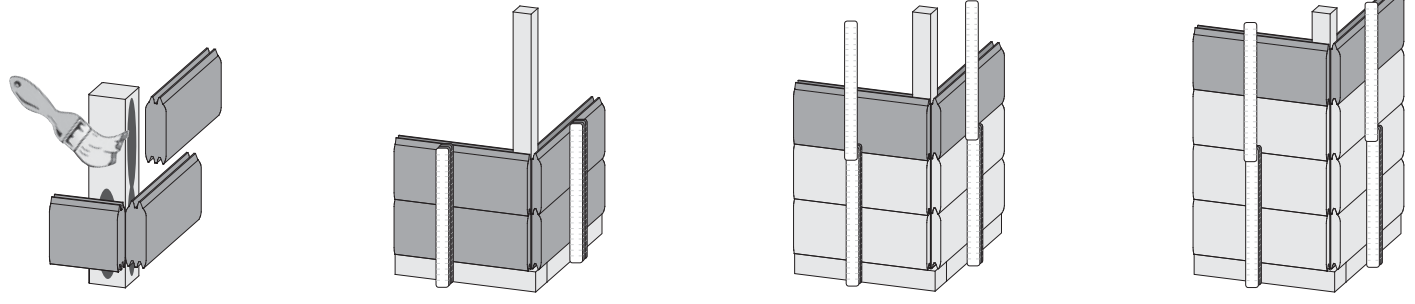

06

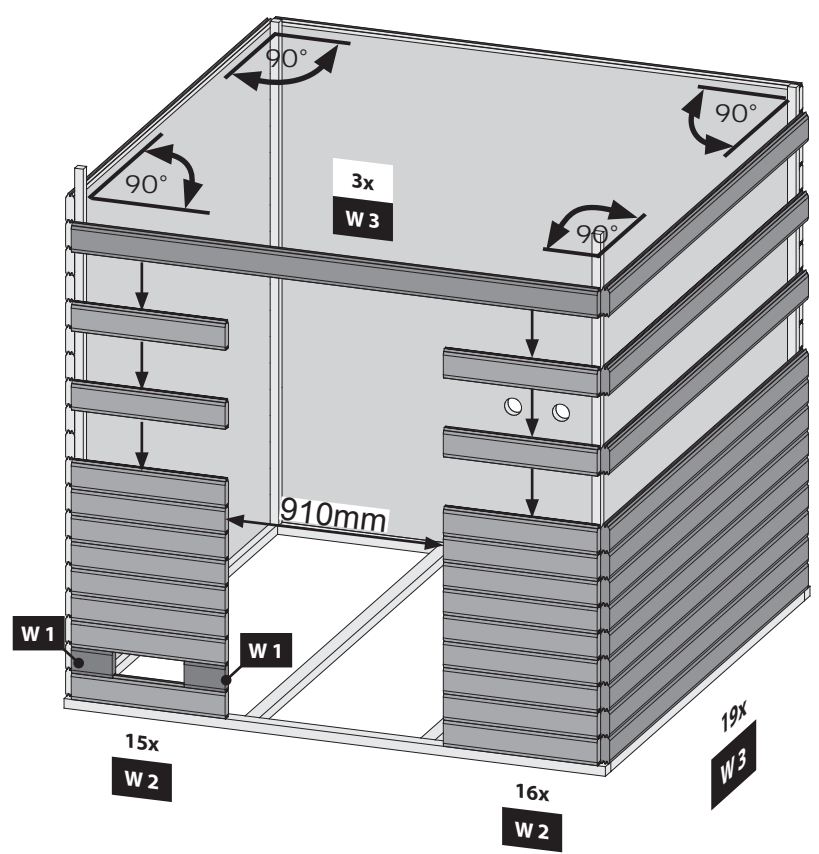
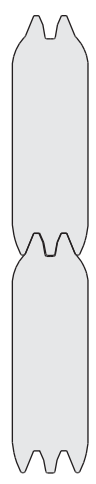
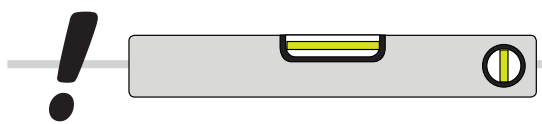
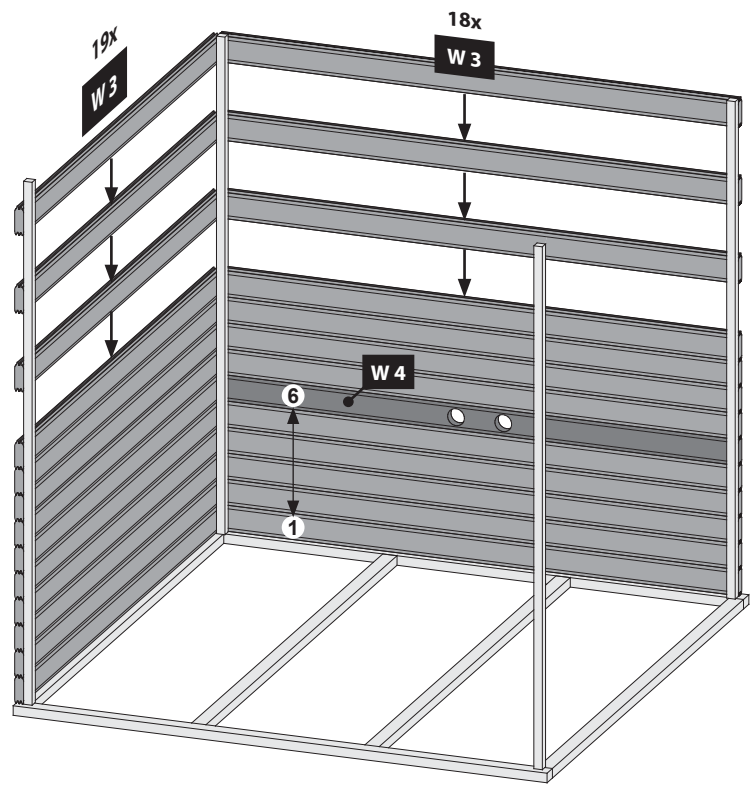
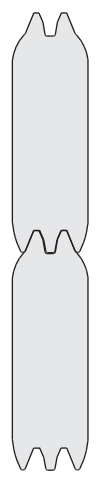

07 2x

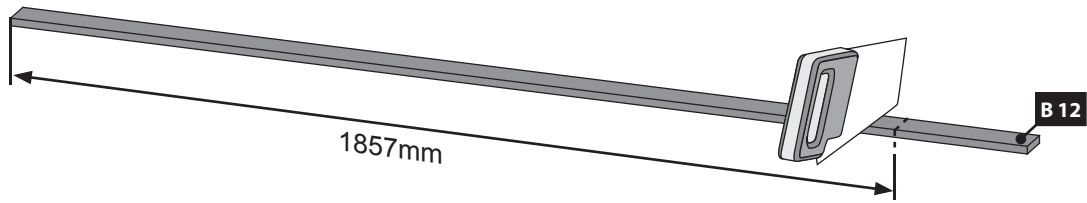

08

-  Bündig!
-  Flush!
-  Affleurement!
-  Gelijk!
-  I flugt!
-  Aras!
-  Combacia!
-  Stejný !

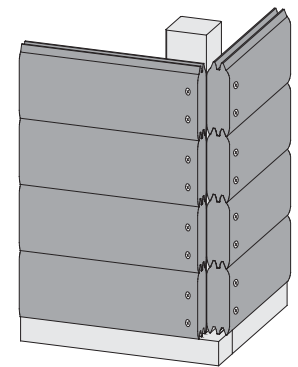
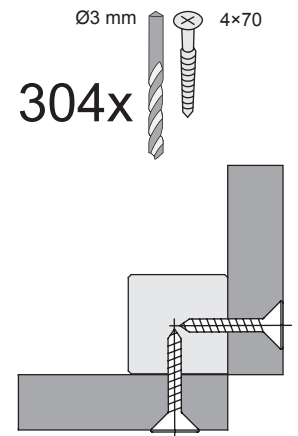
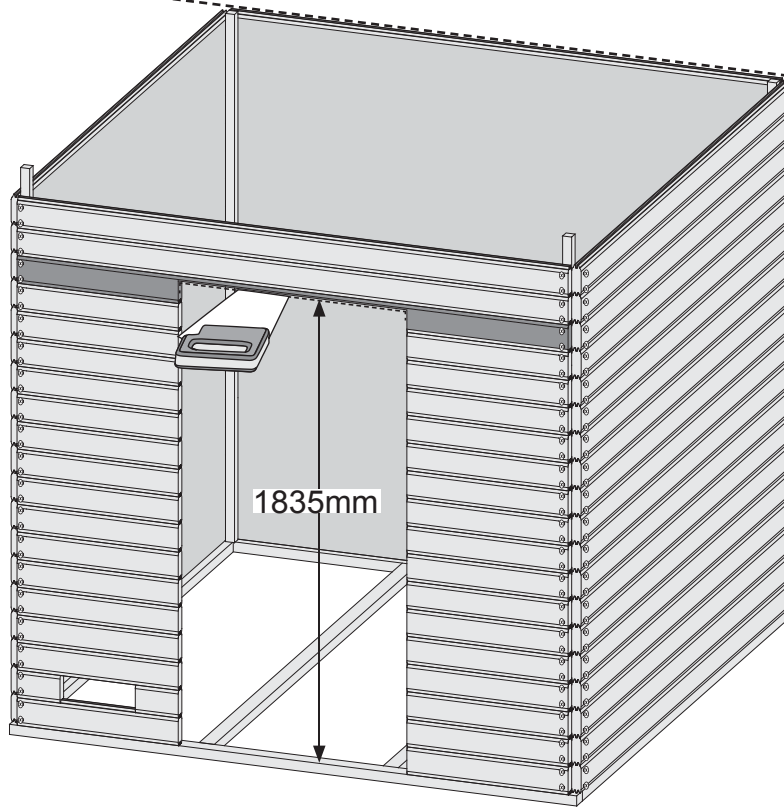

-  Ansicht innen
-  View Inside
-  Voir à l'intérieur
-  Bekijk binnen
-  Ver dentro
-  Visualizza dentro
-  Zobrazit uvnitř
-  Se inde

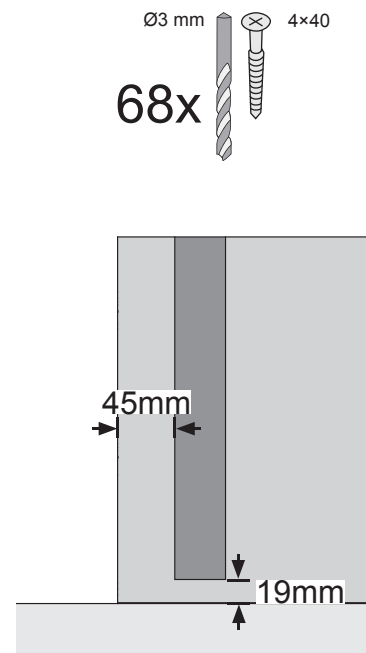
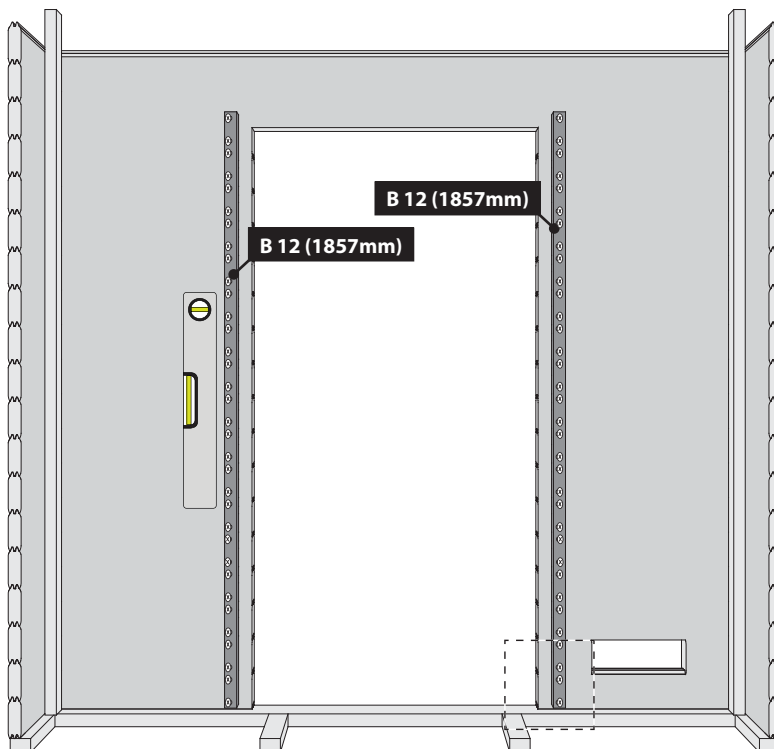

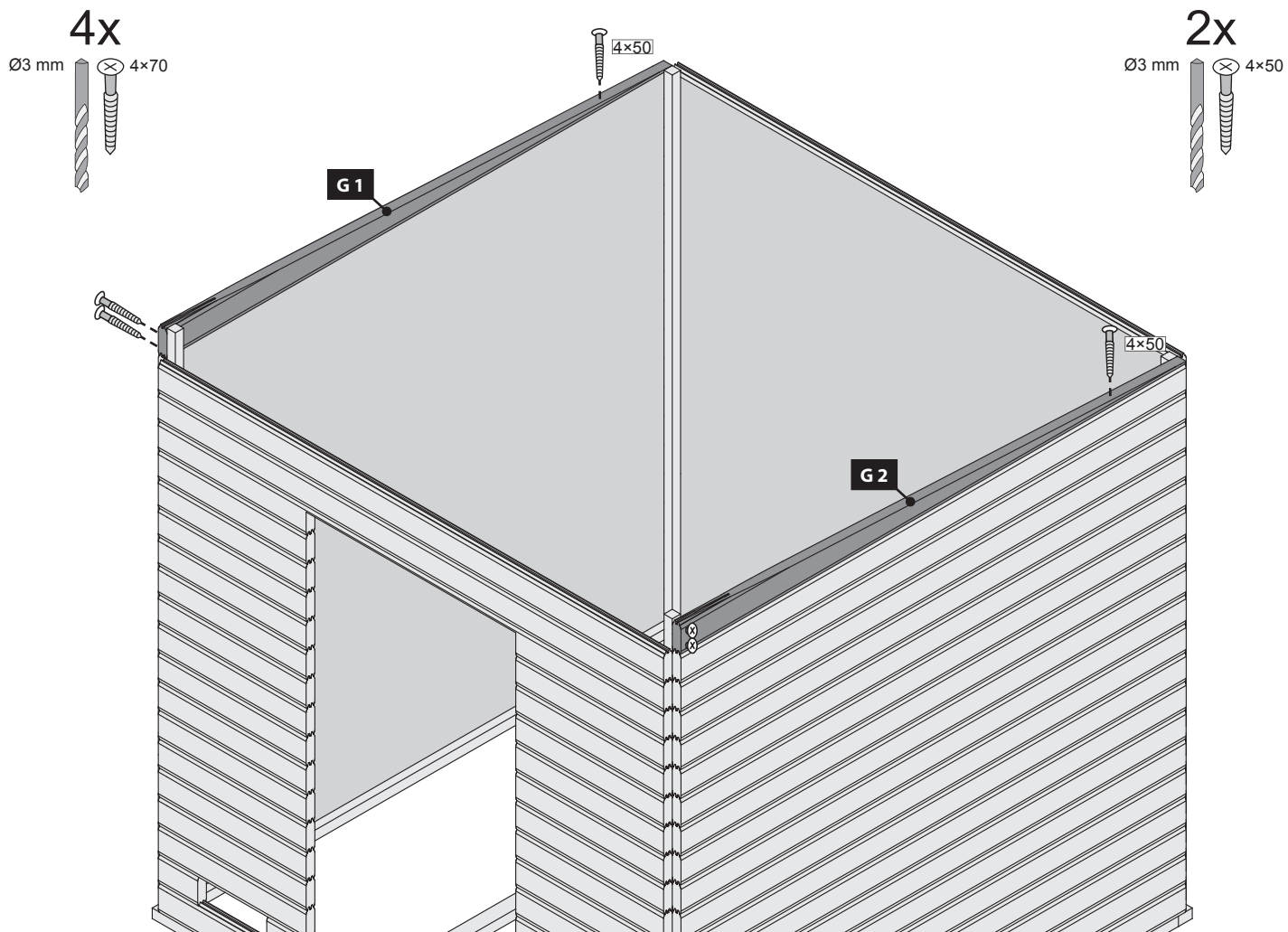

-  Bündig!
-  Flush!
-  Affleurement!
-  Gelijk!
-  I flugt!
-  Aras!
-  Combacia!
-  Stejný !

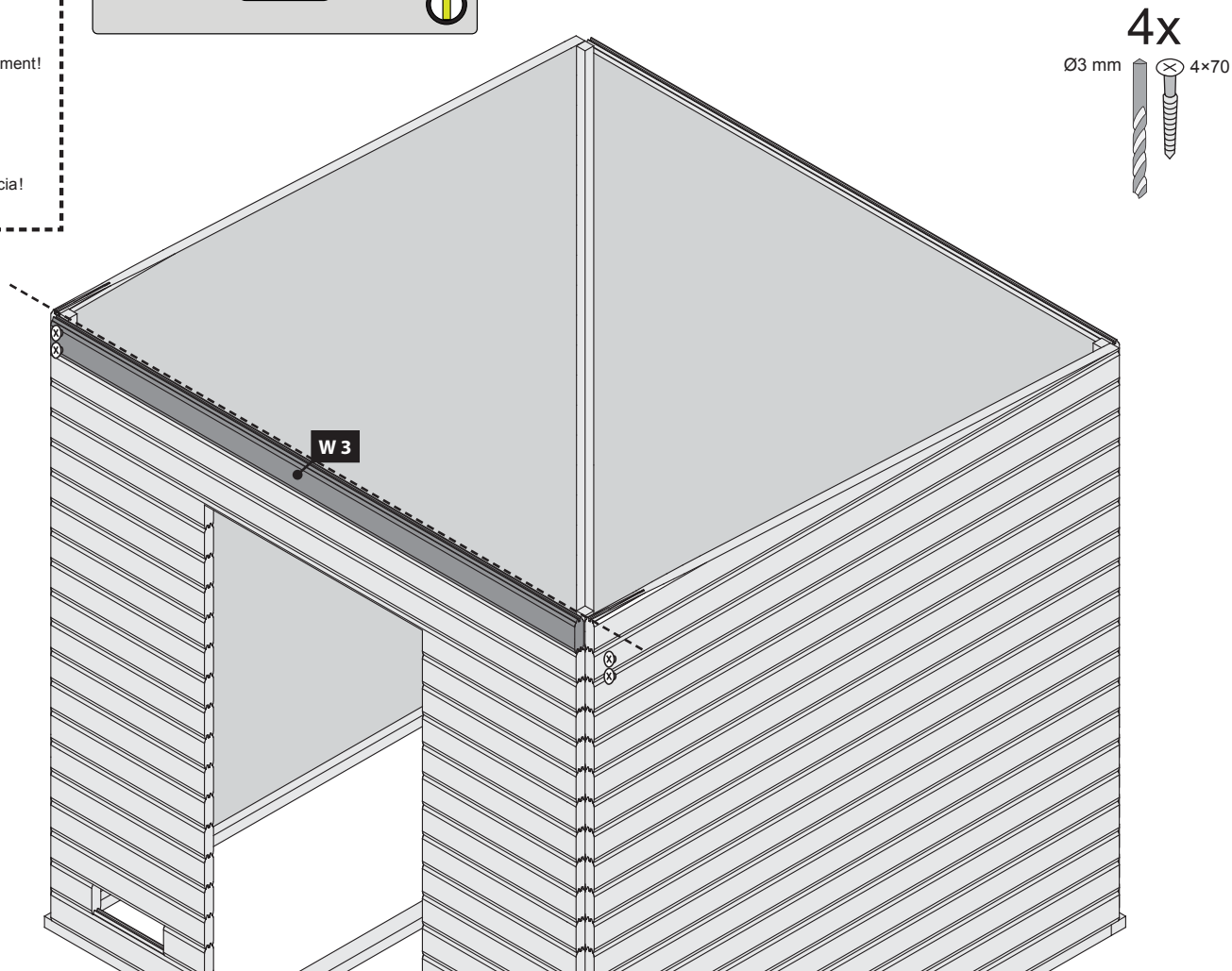



- Breite Seite nach oben
- Width side up
- Largeur vers le haut
- Breedte side up

- Ancho de banda de hasta
- Larghezza verso l'alto
- Šířka stranou nahoru
- Bred side op

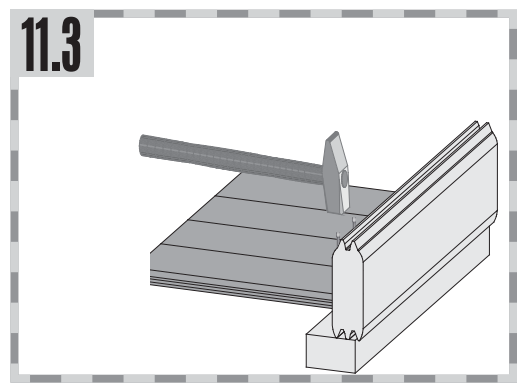
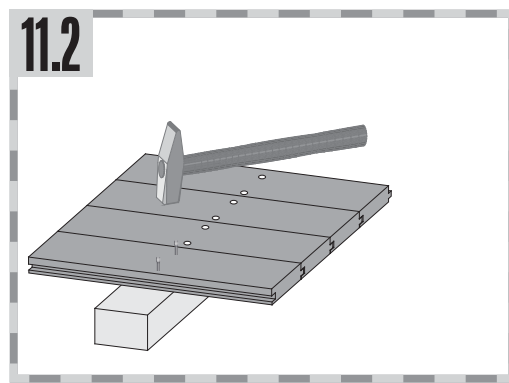
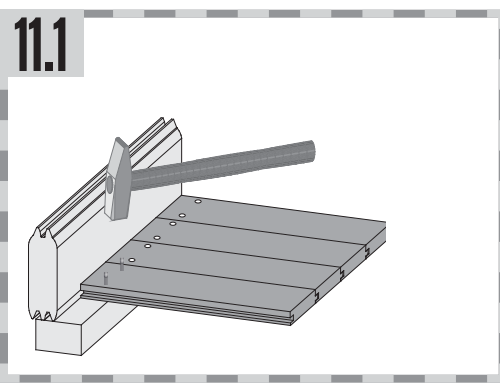
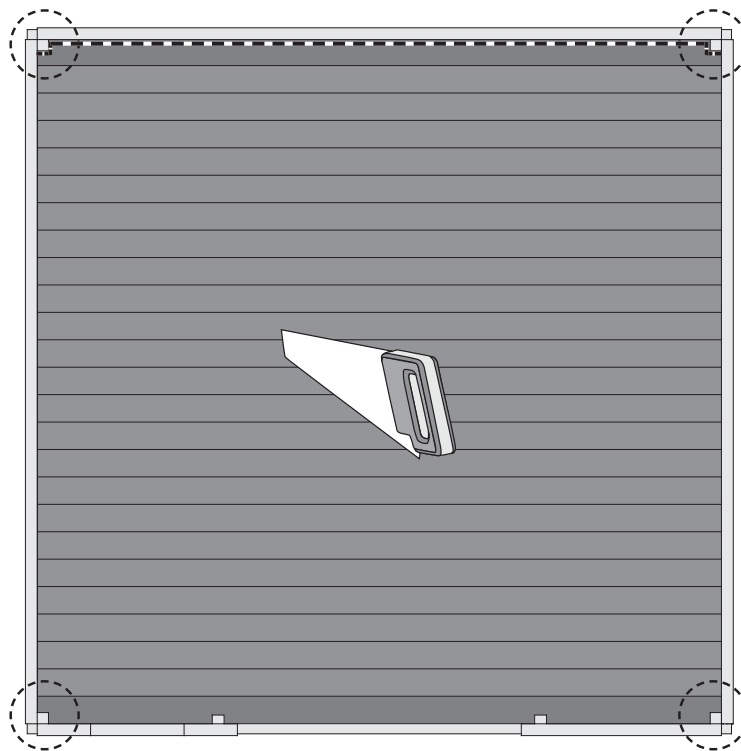
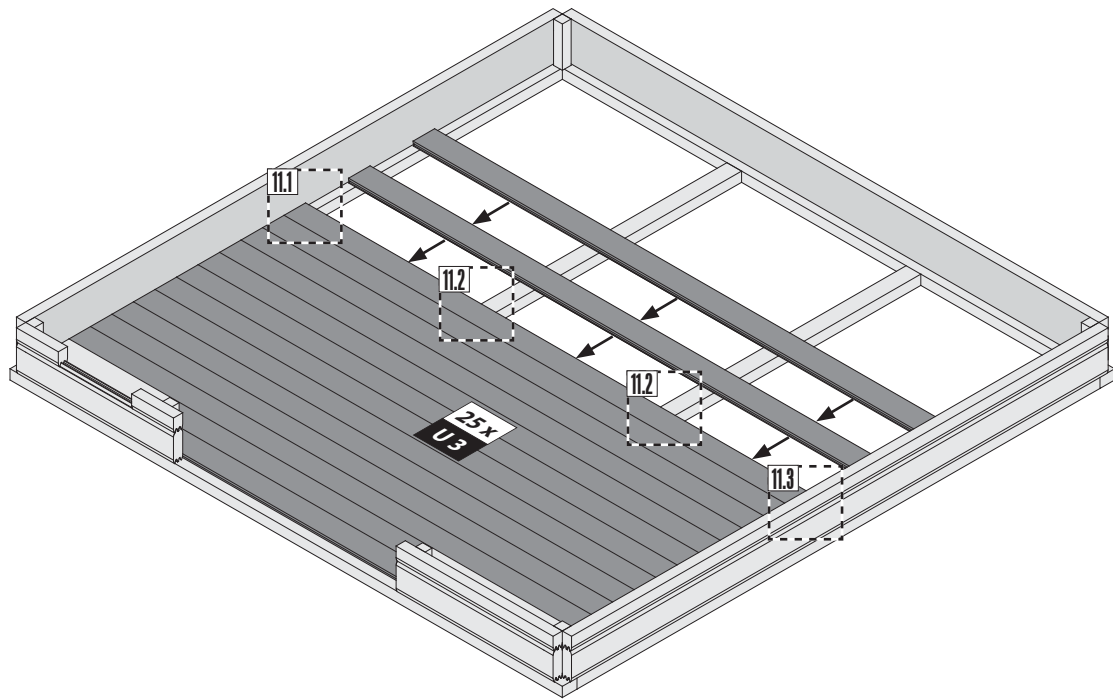

 ausrichten  
 align  
 aligner

 richten  
 tilpasse  
 alinear

 allineare  
 seřadit

12

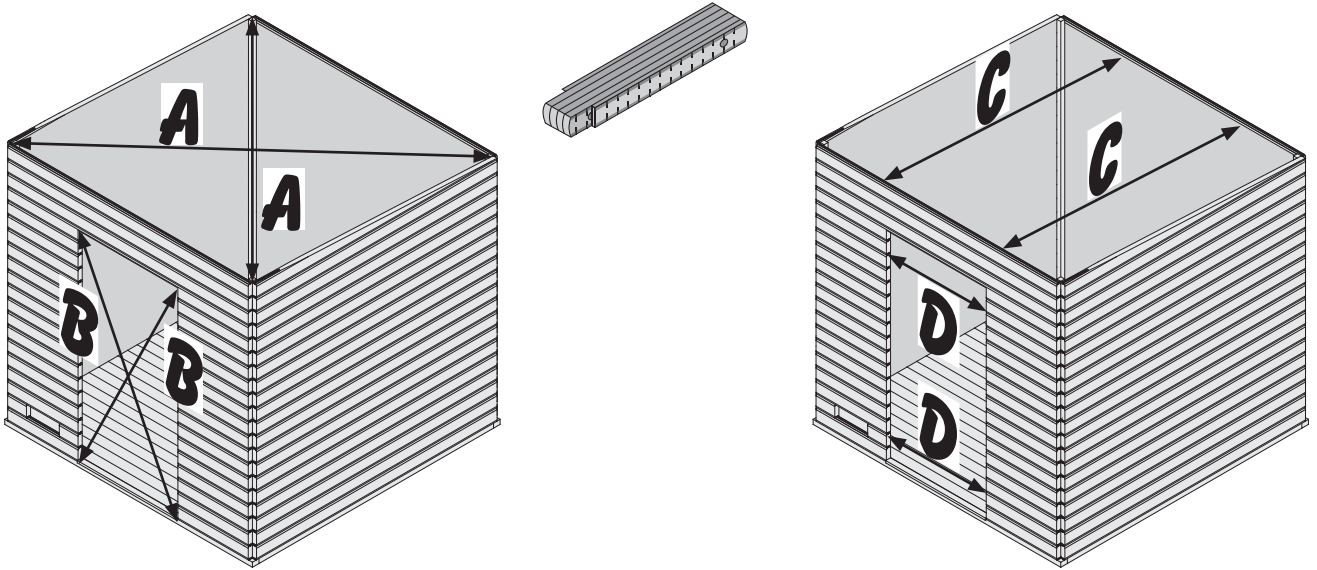

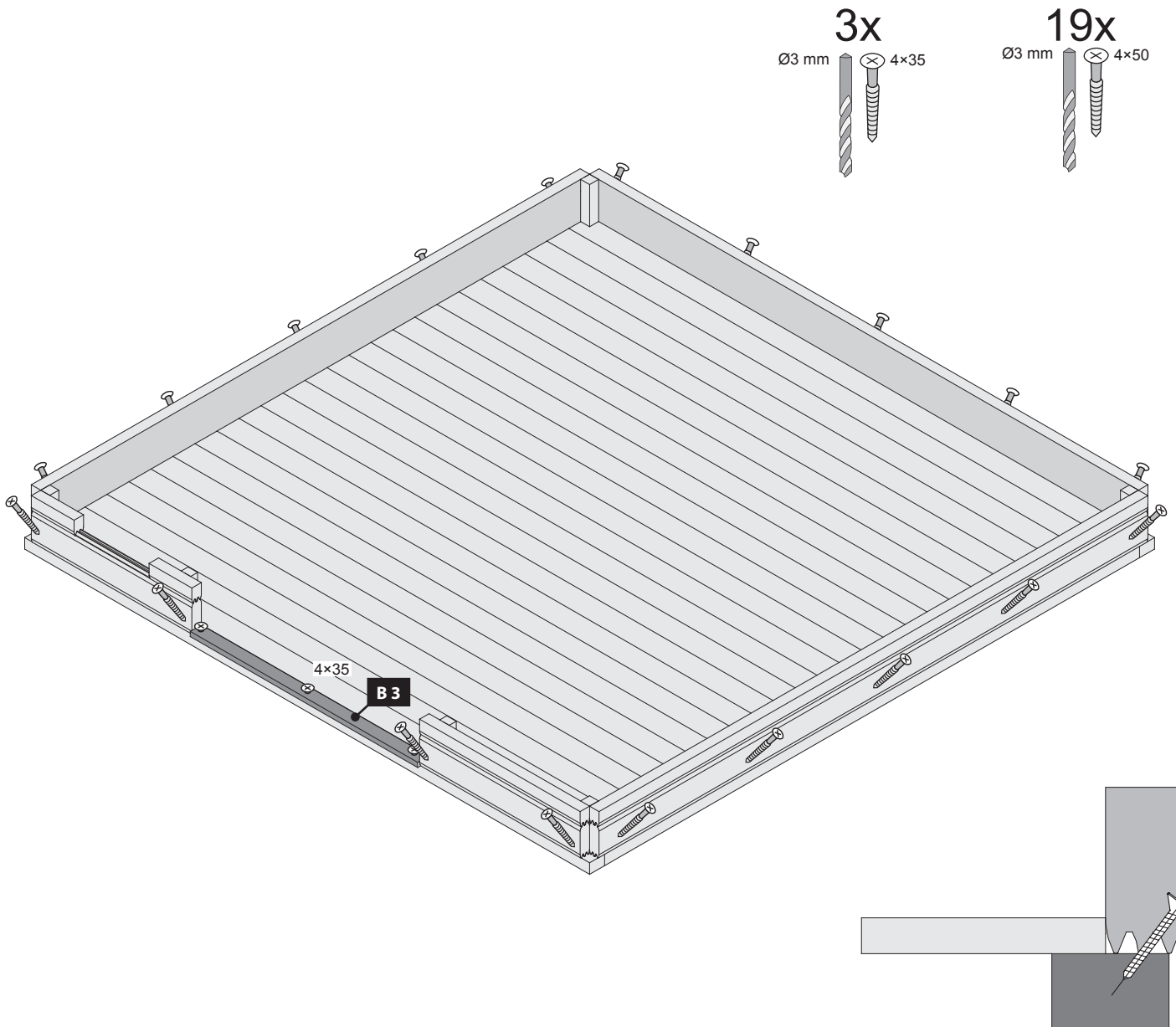

13

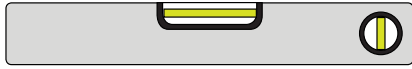
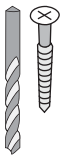

24x

Ø3 mm 4x40



-  Bündig!
-  Flush!
-  Affleurement!
-  Gelijk!
-  I flugt!
-  Aras!
-  Combacia!
-  Stejný!

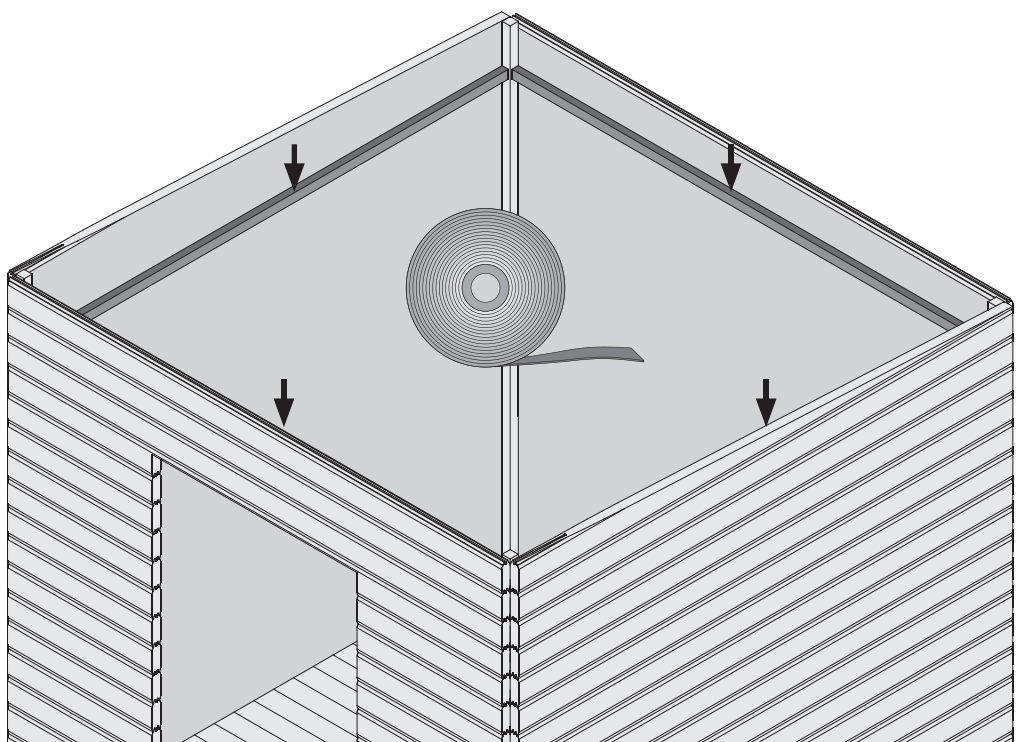
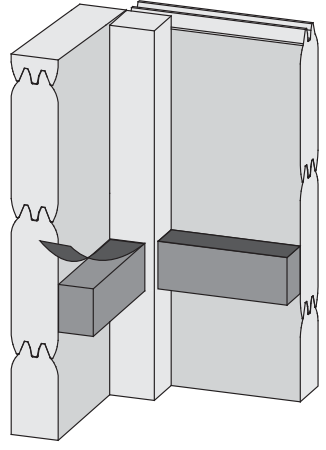
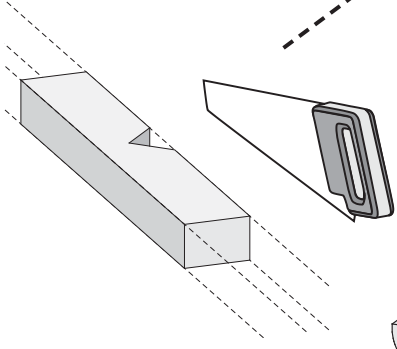
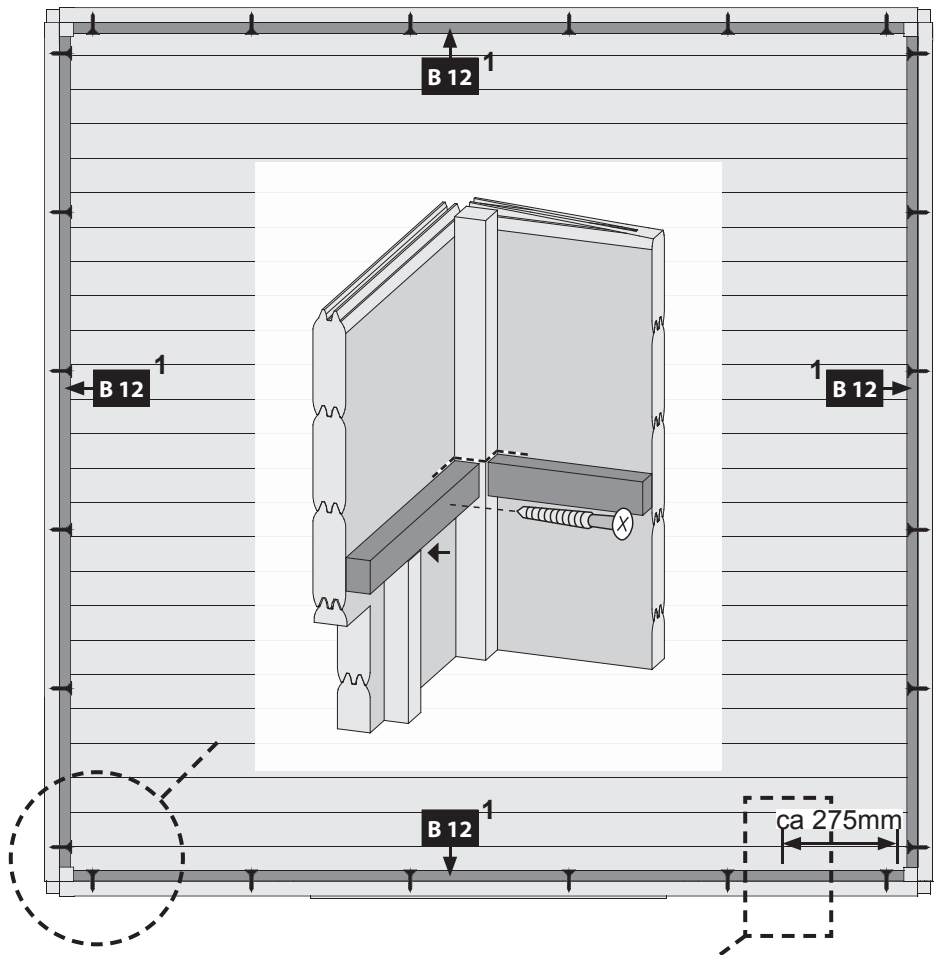

-  Sauna Dichtband
-  Sauna sealing tape
-  Ruban d'étanchéité pour sauna
-  Sauna tætningsbånd
-  Sauna afdichtingstape
-  Cinta de sellado de sauna
-  Nastro sigillante per sauna
-  Sauna těsnící páska

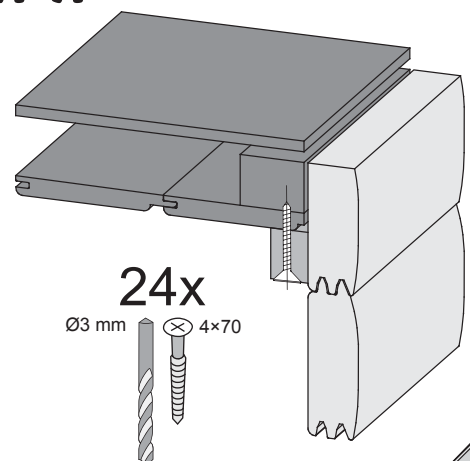
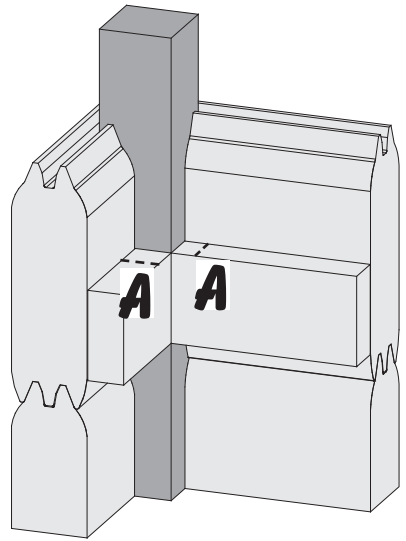
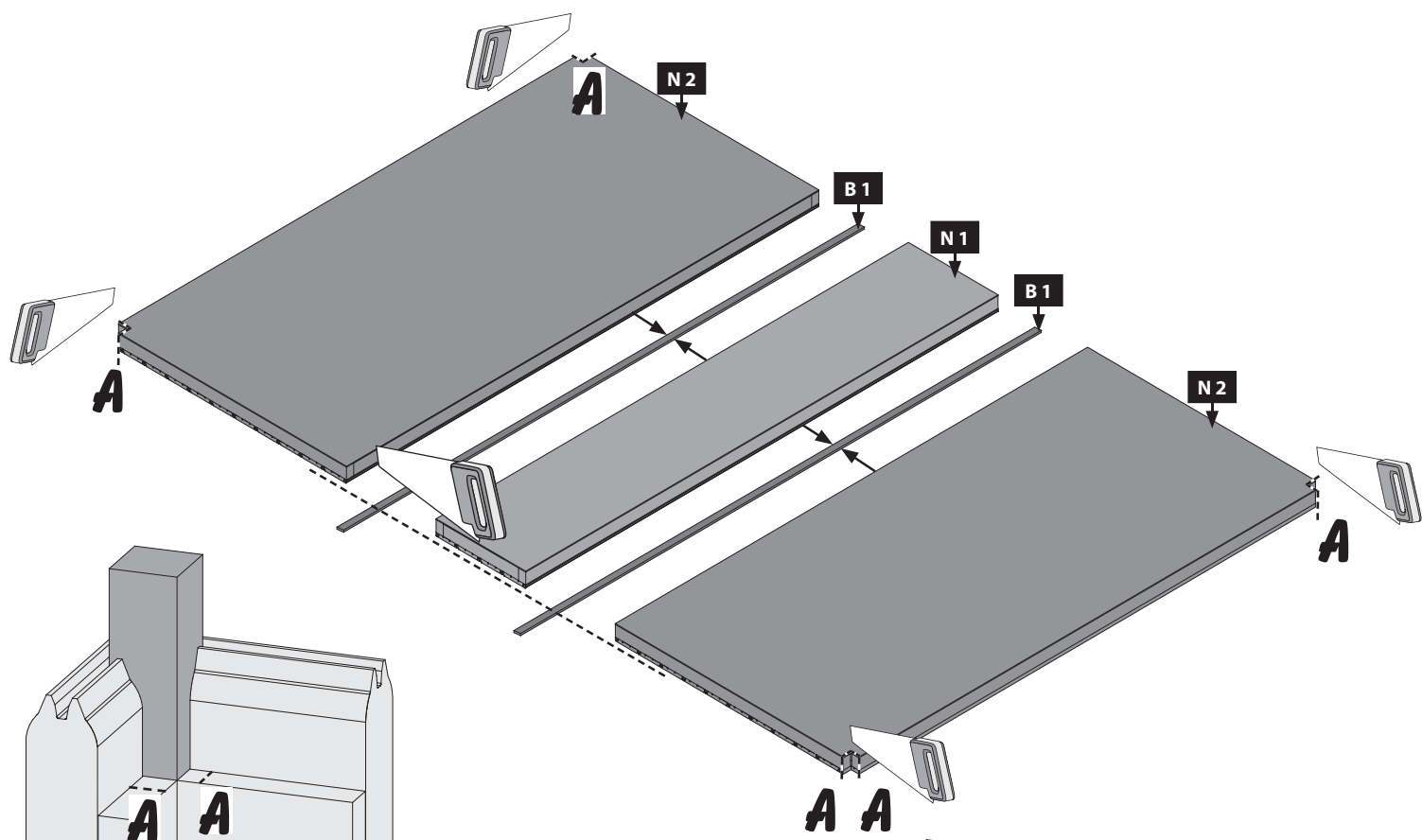

24x  
Ø3 mm 4x70

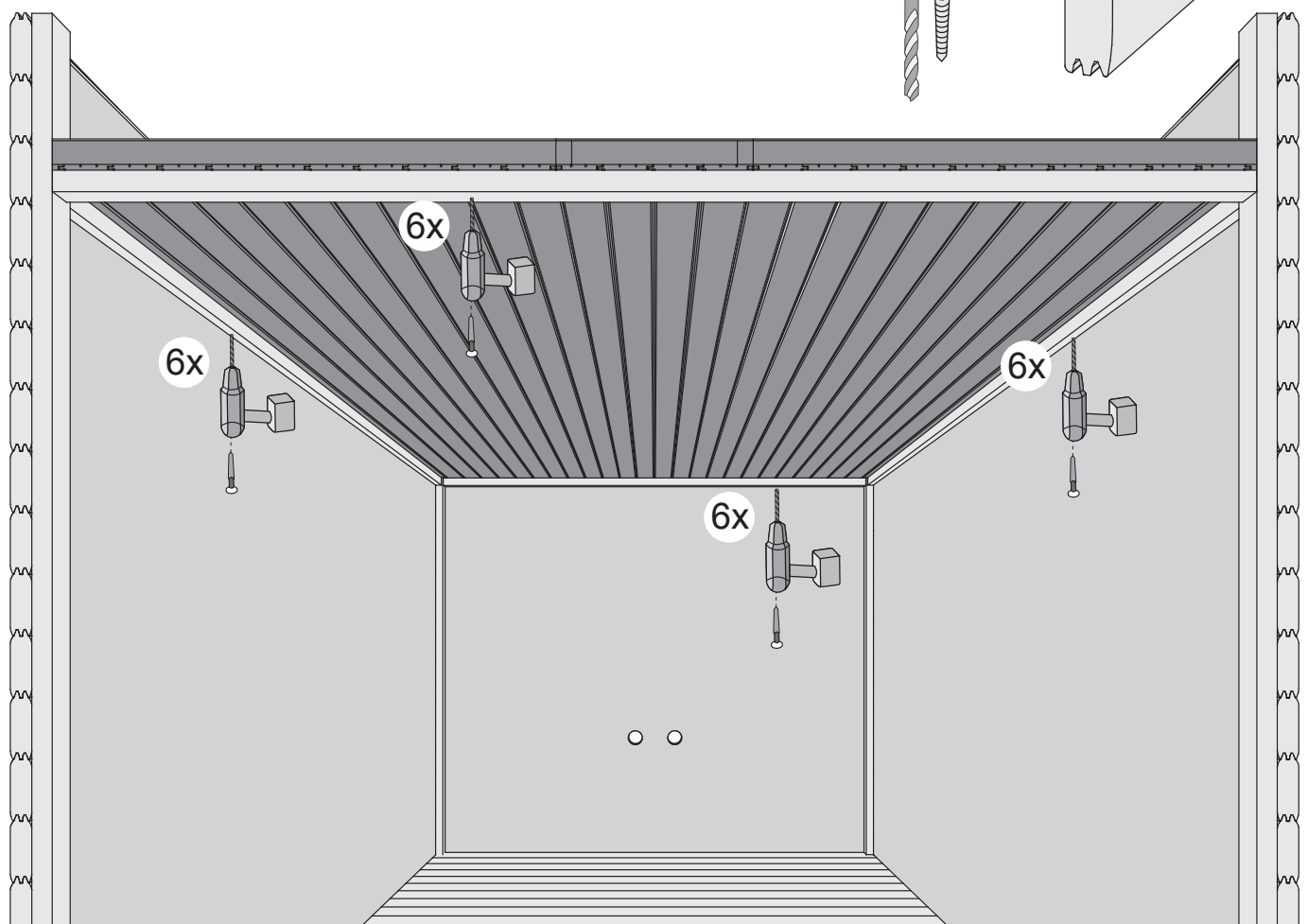





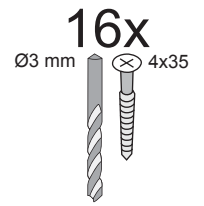
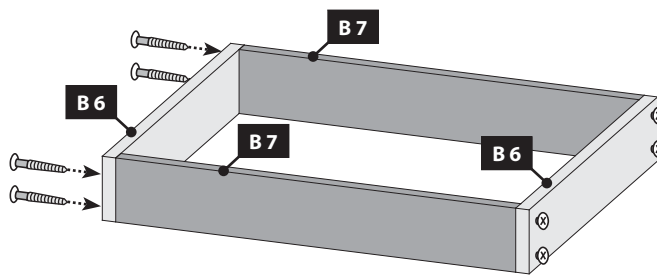



16 2x



17 a

-  Nur bei 4,5 / 9 kW-Ofen
-  Seulement 4,5 / 9 kW chauffe
-  Only 4,5 / 9 kW heater
-  Slechts 4,5 / 9 kW heater
-  Sólo calentador de 4,5 / 9 kW
-  Solo riscaldamento 4,5 / 9 kW
-  Pouze topné těleso 4,5 / 9 kW

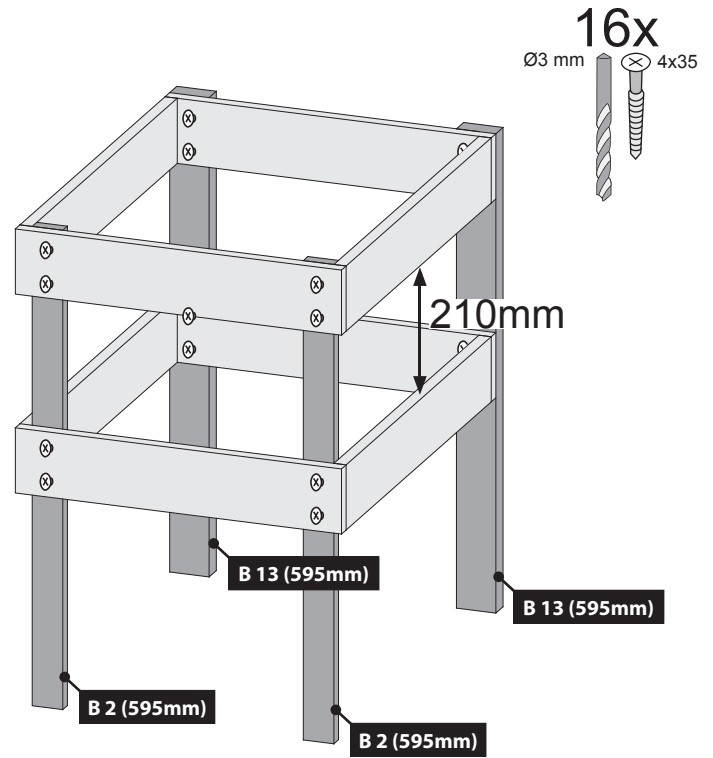
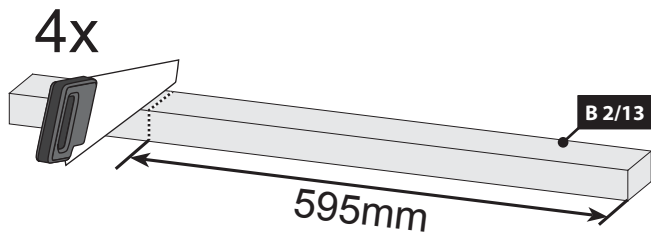

17 b

-  Bei allen anderen Öfen
-  Pour tous les autres fours
-  For all other furnaces
-  Voor alle andere ovens
-  Para todos los otros hornos
-  Per tutti gli altri tipi di forni
-  U všech ostatních pecích

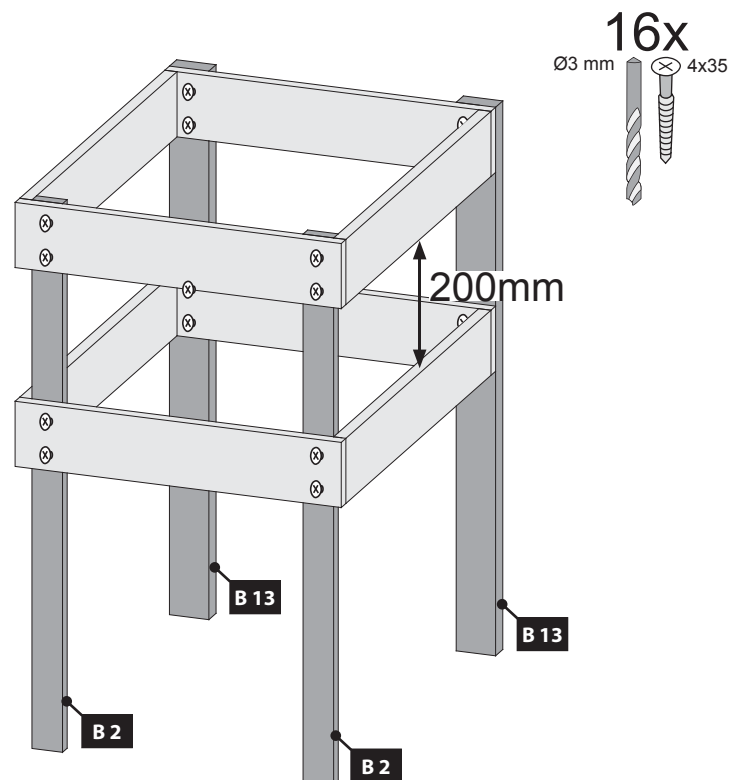

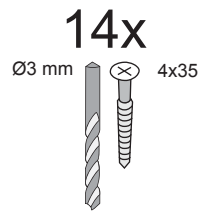
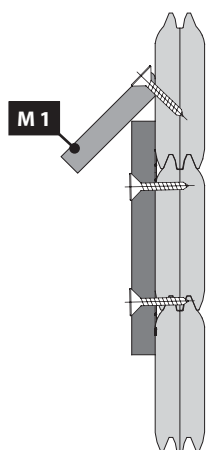
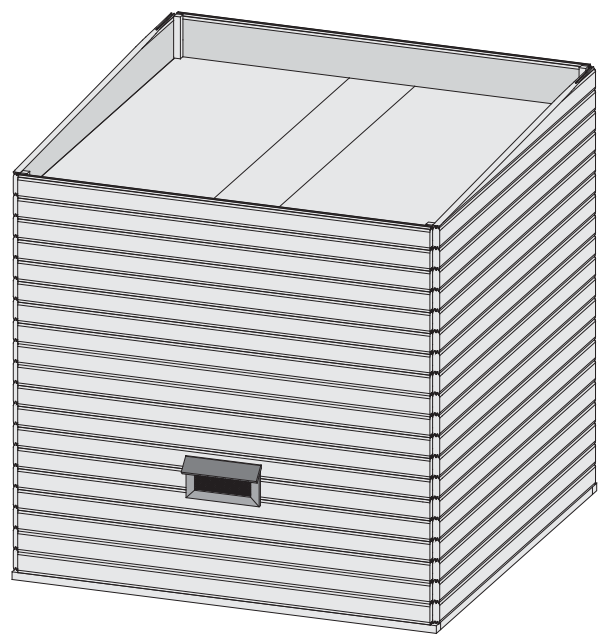
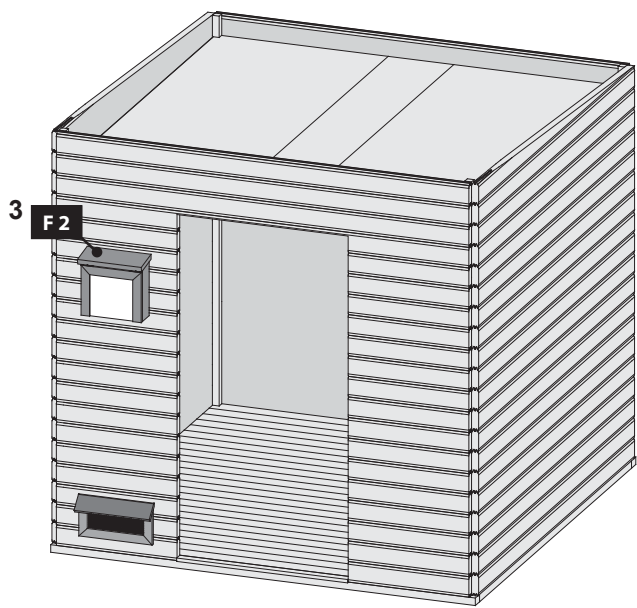

3

- Aufbauanleitung
- Building Instructions
- notice de montage
- montagehandleiding
- Montagevejledning
- Instrucciones de construcción
- Istruzioni per il montaggio
- Montážní návod

Karibu Holztechnik GmbH • Eduard-Sulling-Str. 17 • 28217 Bremen info@karibu.de

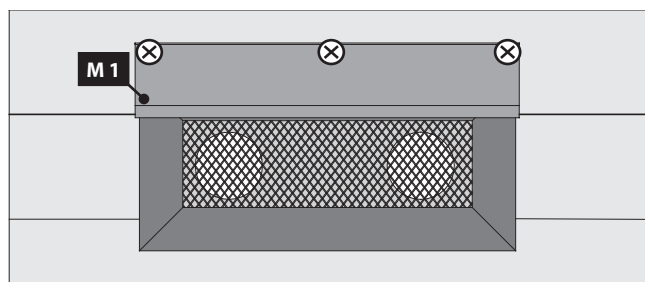
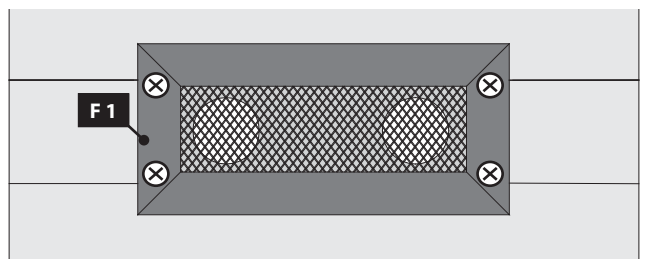

19

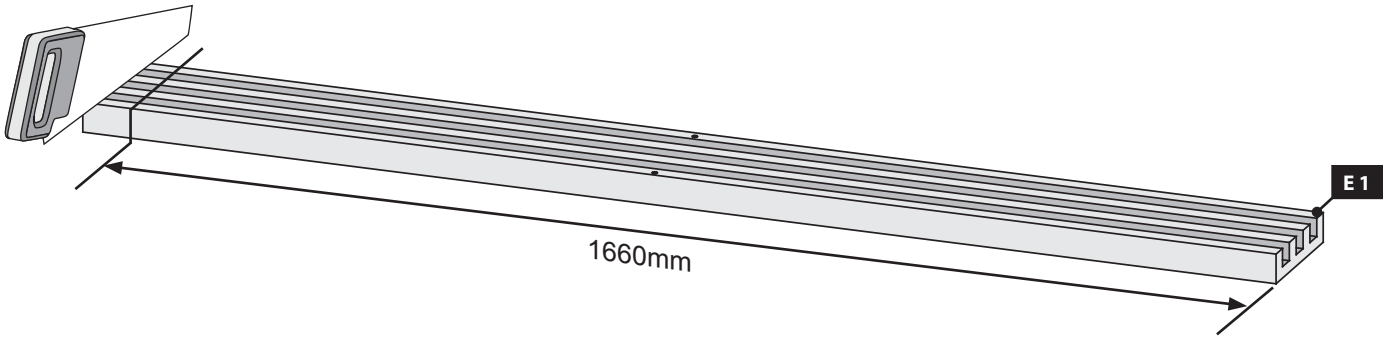

20

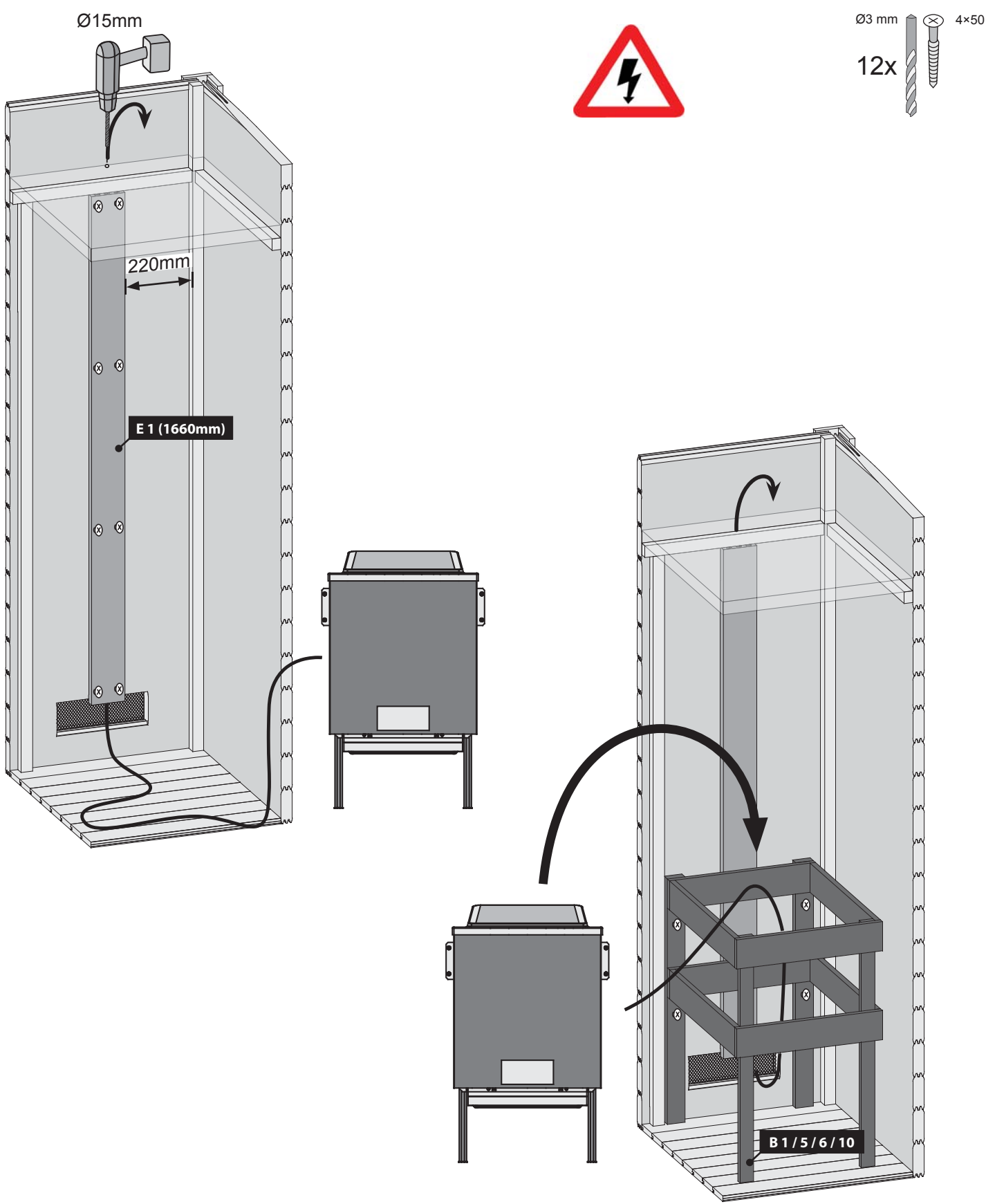

21 2x

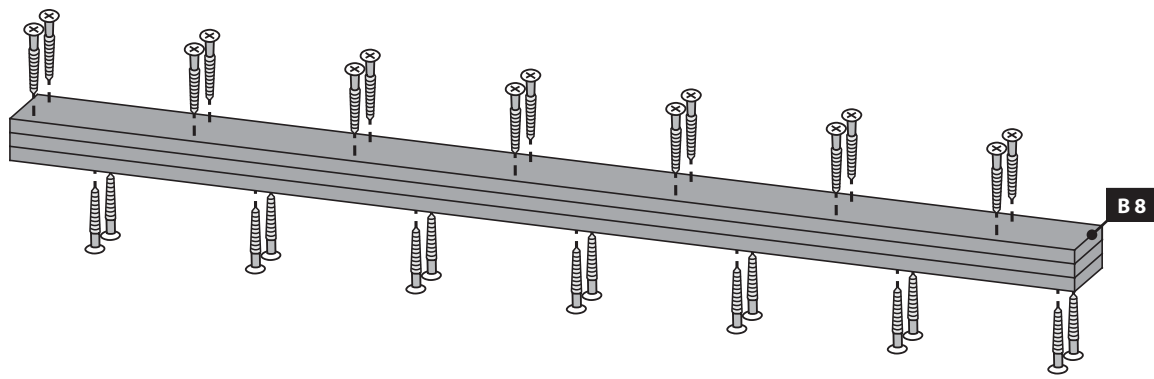

56x  
Ø3 mm 4x50

Drill bit and screw for step 21.

22

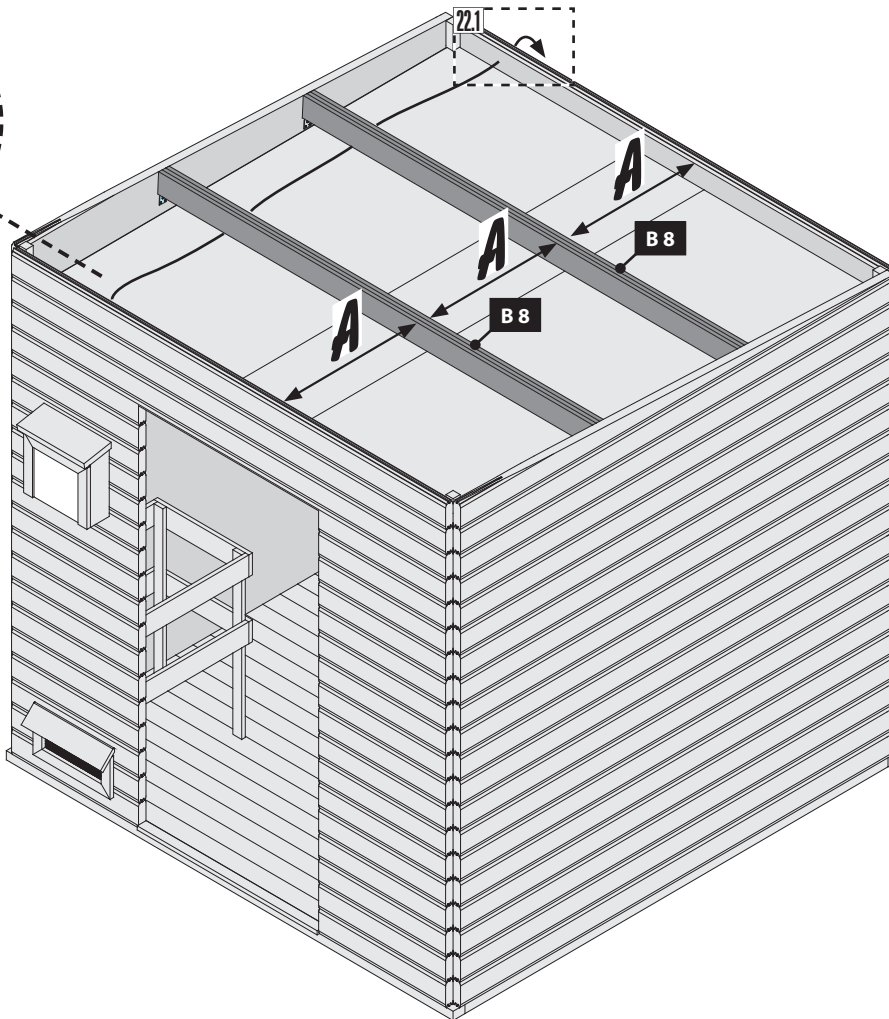
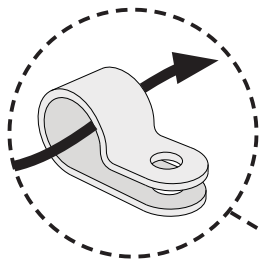

32x  
Ø3 mm 4x30

Drill bit and screw for step 22.

22.1-1

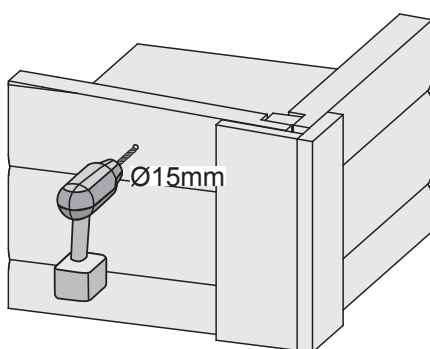

22.1-2

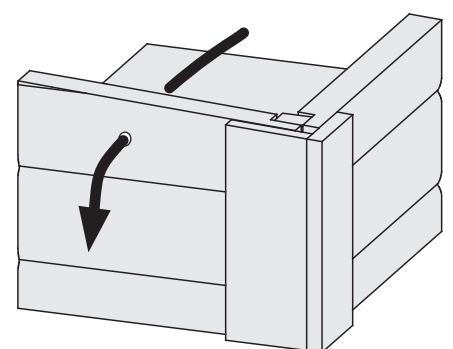



-  Schmale Seite nach außen
-  Narrow side out
-  Côté étroit sur
-  Smalle zijde out
-  Lado estrecho hacia fuera
-  Narrow lato fuori
-  Úzké boční out

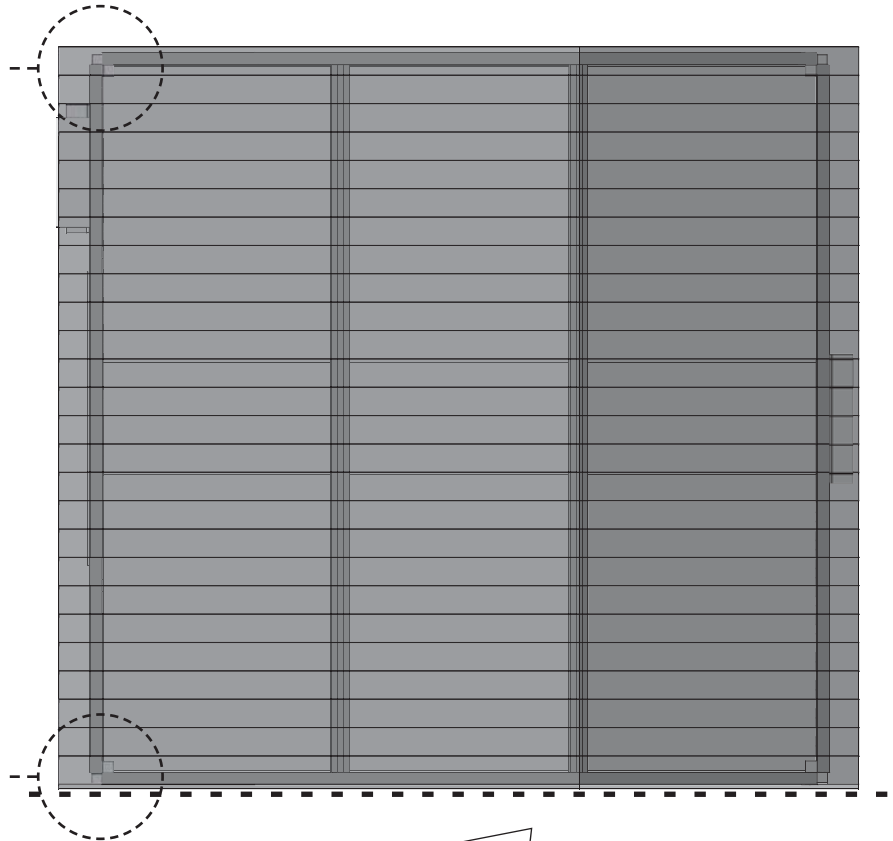
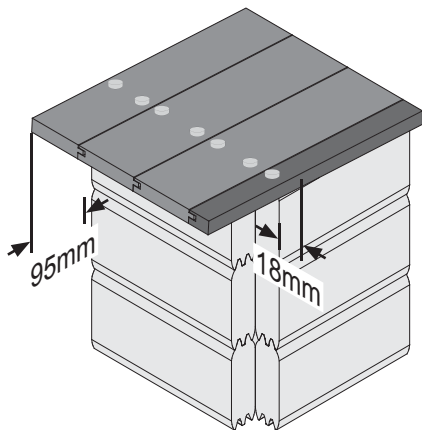
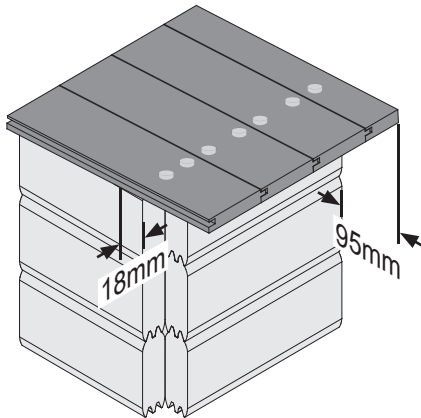
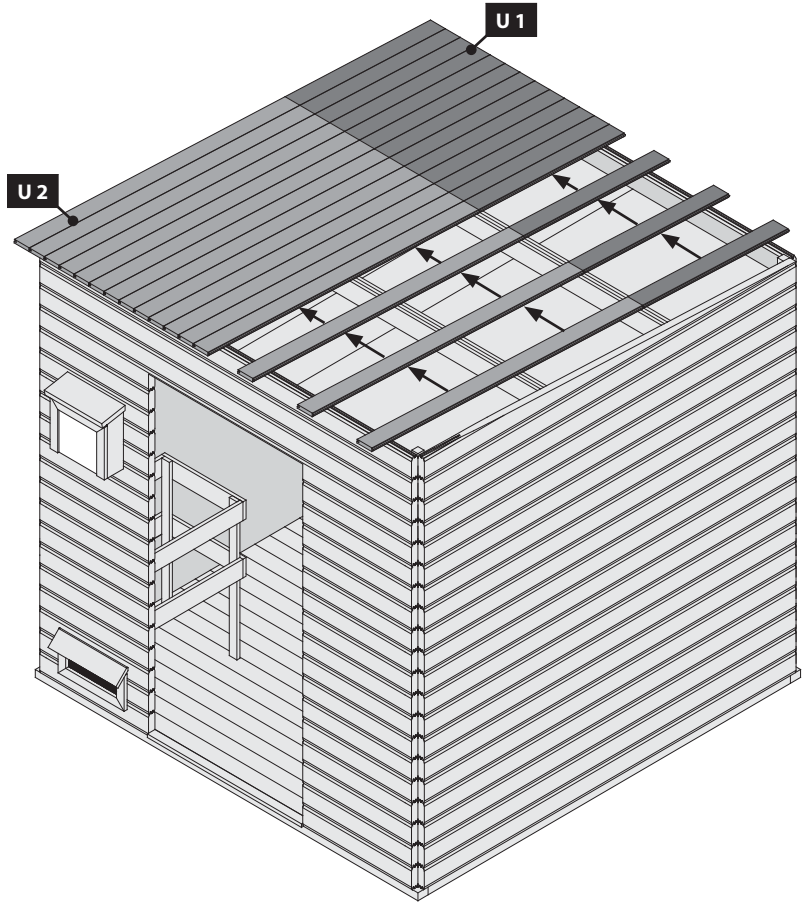
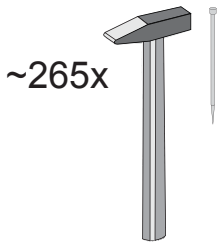

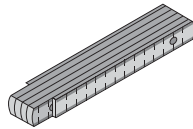

32x

Ø3 mm 4x35

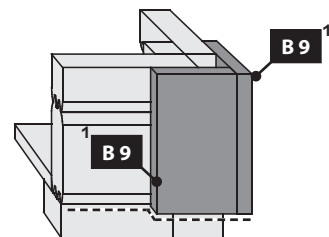
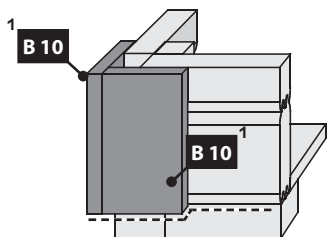
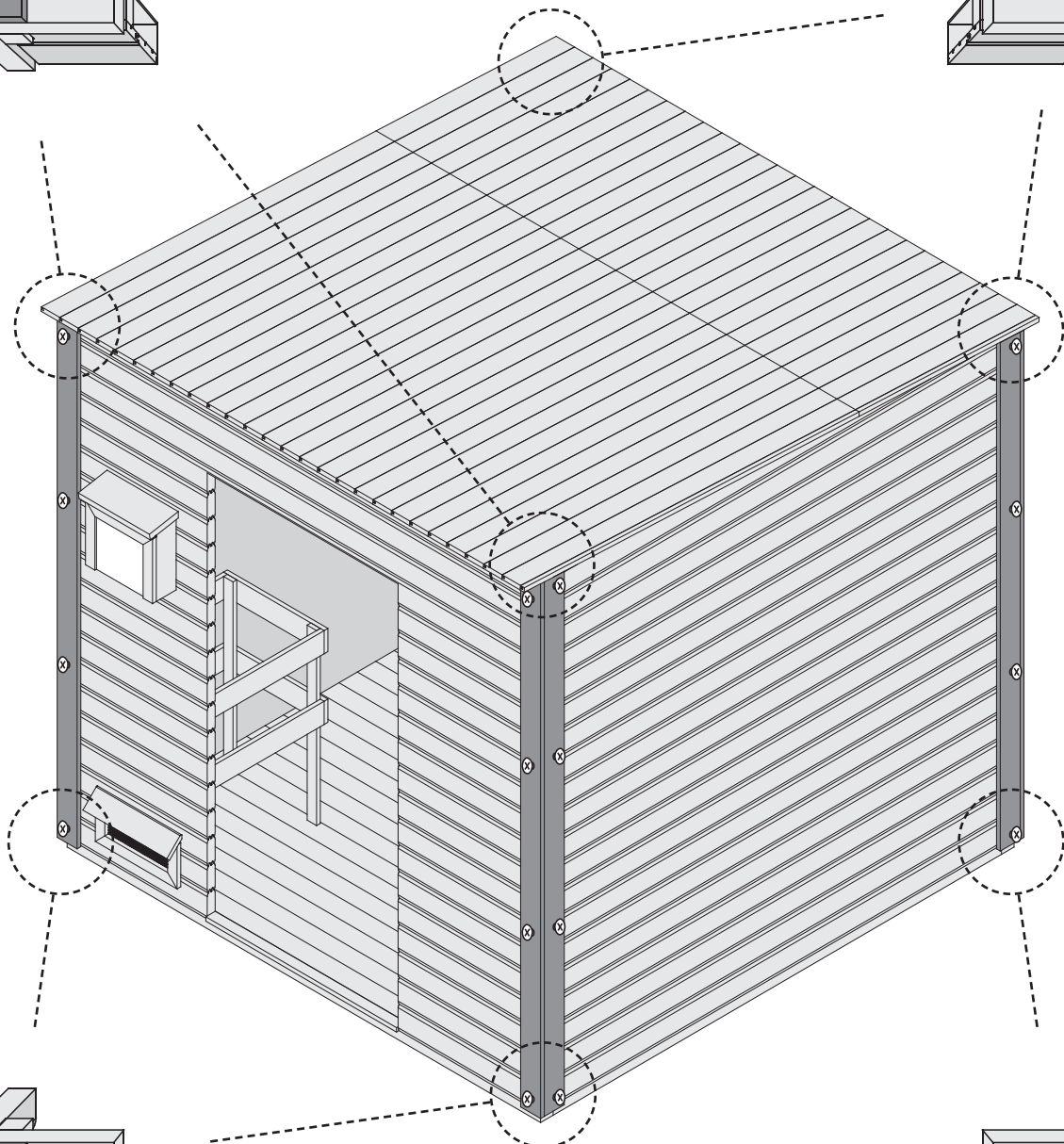
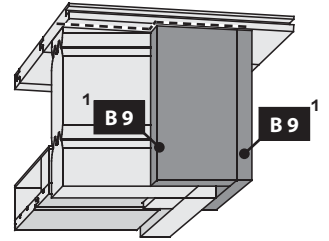
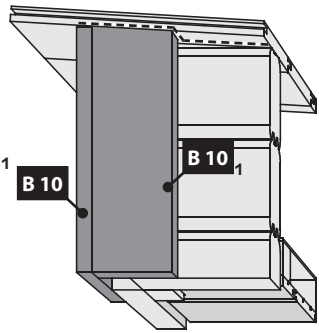
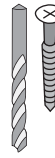

- <sup>1</sup> Länge muss ermittelt und zugesägt werden
- Length must be determined and sawn
- La longueur doit être déterminée et sciée
- De lengte moet worden bepaald en worden gezaagd

- La longitud debe ser determinada y aserrada
- La lunghezza deve essere determinata e segata
- Délka musí být určena a rozřezána
- Længden skal bestemmes og savet



9x

Ø3 mm 4x35

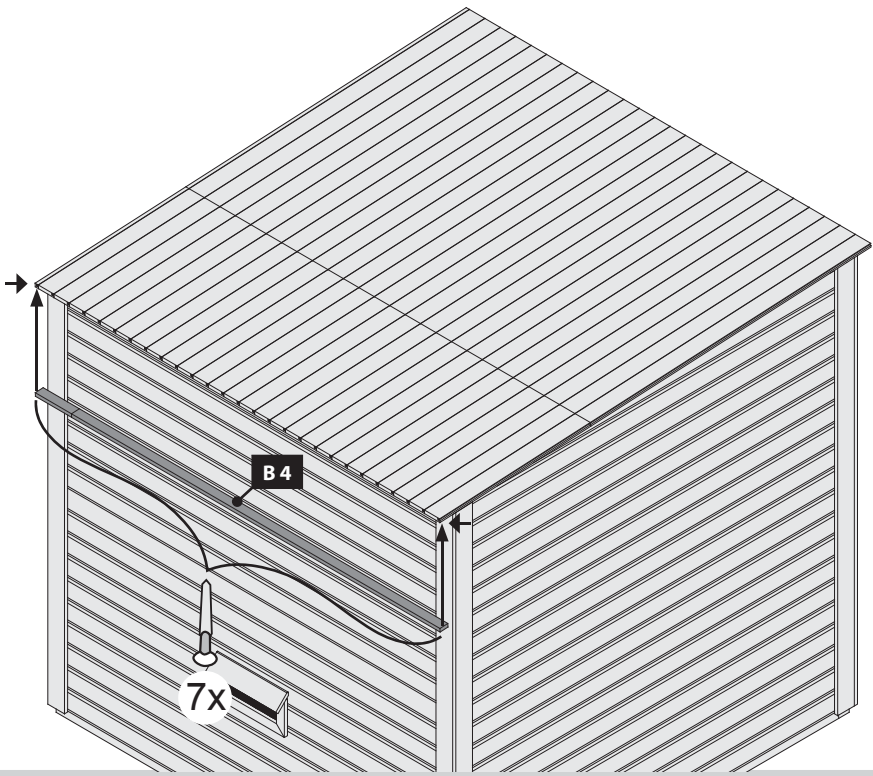
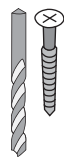

Bündig!  
 Flush!  
 Affleurement!  
 Gelijk!  
 I flugt!  
 Aras!  
 Combacia!  
 Stejný !

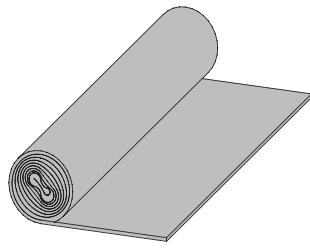
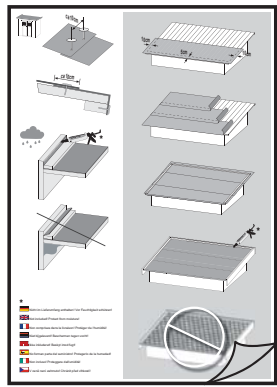

- \*
- Nicht im Lieferumfang enthalten
  - Not included
  - Non comprises dans la livraison
  - Niet bijgeleverd
  - No forman parte del suministro
  - Non incluso
  - V ceně není zahrnuto
  - Ikke inkluderet

27x

Ø3 mm 4x35

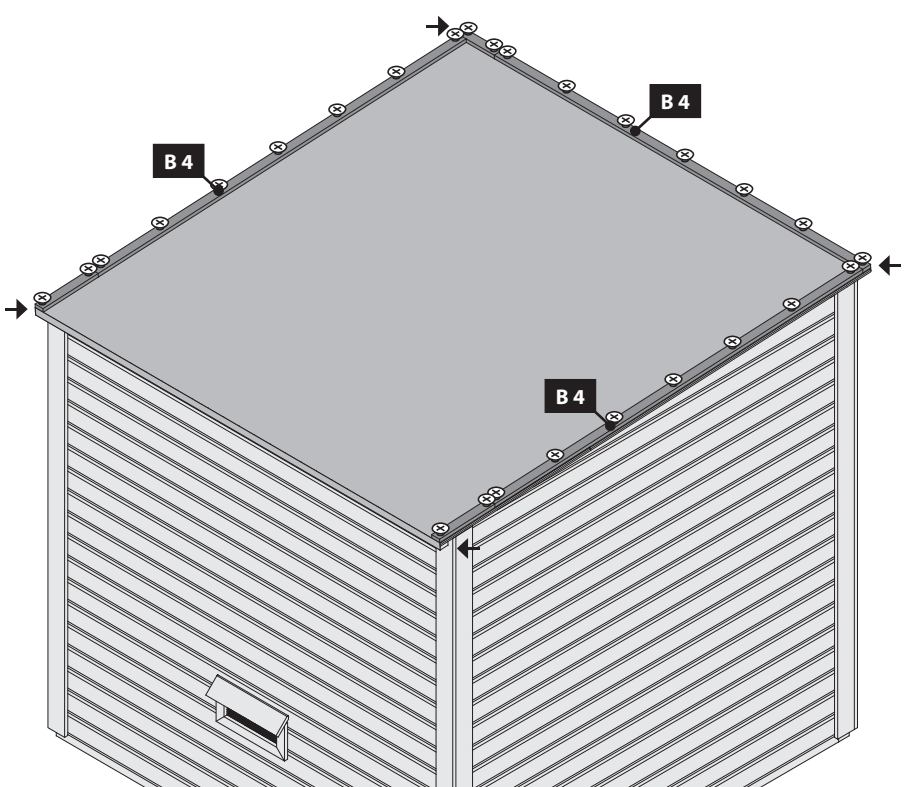
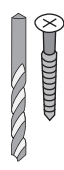

Bündig!  
 Flush!  
 Affleurement!  
 Gelijk!  
 I flugt!  
 Aras!  
 Combacia!  
 Stejný !

27

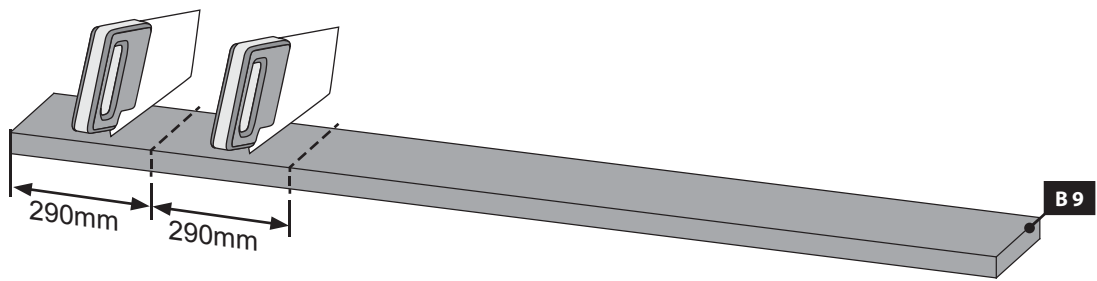

28

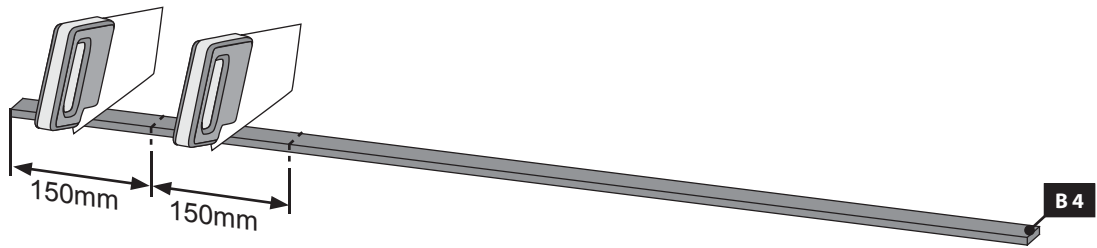

29

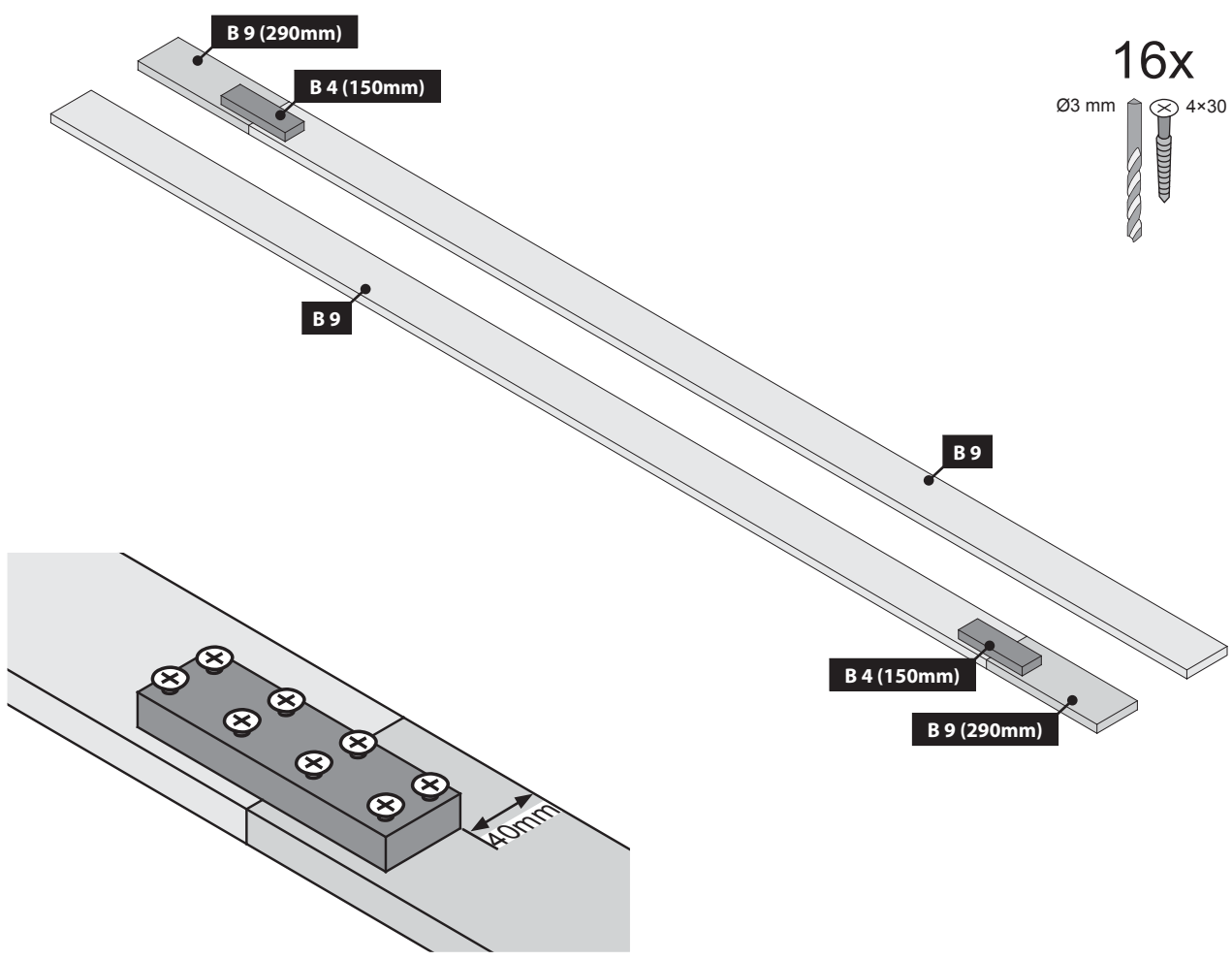



16x

Ø3 mm 4x40

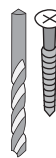

-  Bündig!
-  Flush!
-  Affleurement!
-  Gelijk!
-  I flugt!
-  Aras!
-  Combacia!
-  Stejný !

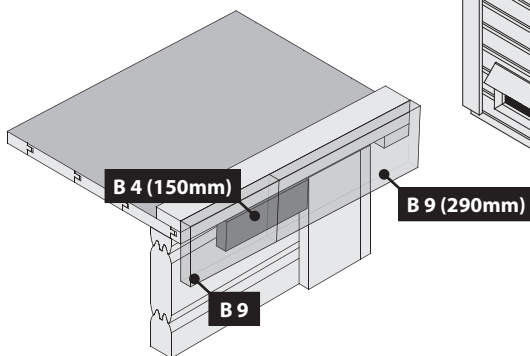
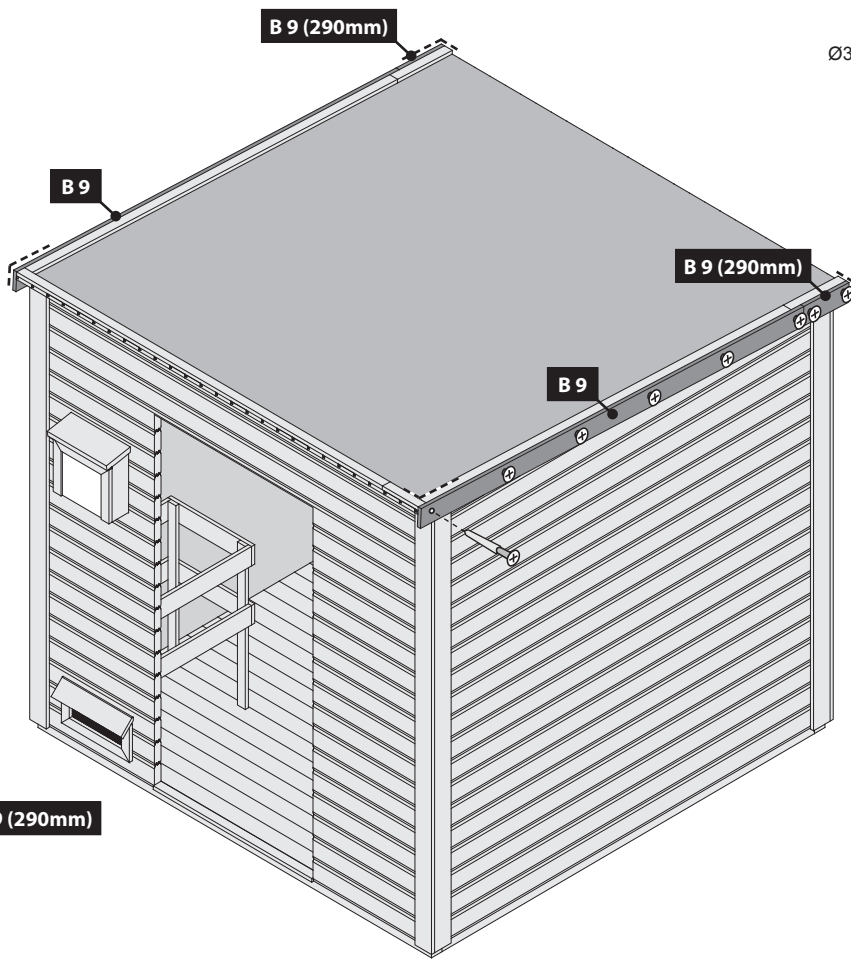

6x

Ø3 mm 4x40

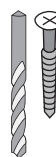

-  Bündig!
-  Flush!
-  Affleurement!
-  Gelijk!
-  I flugt!
-  Aras!
-  Combacia!
-  Stejný !

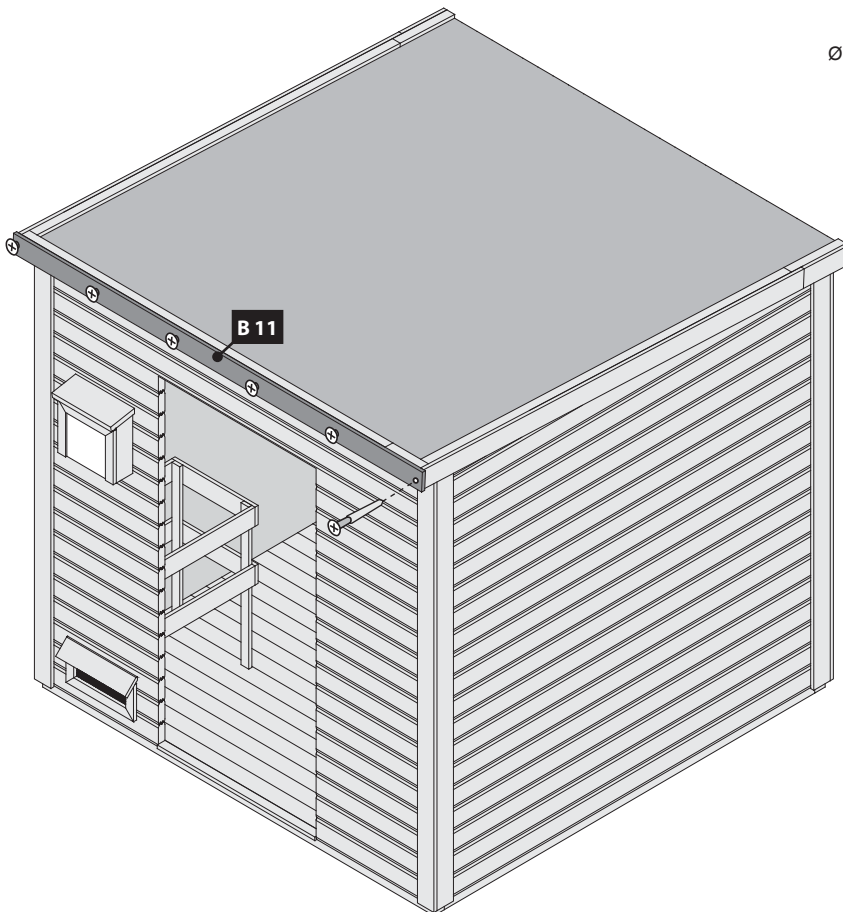

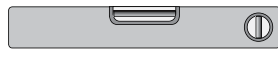
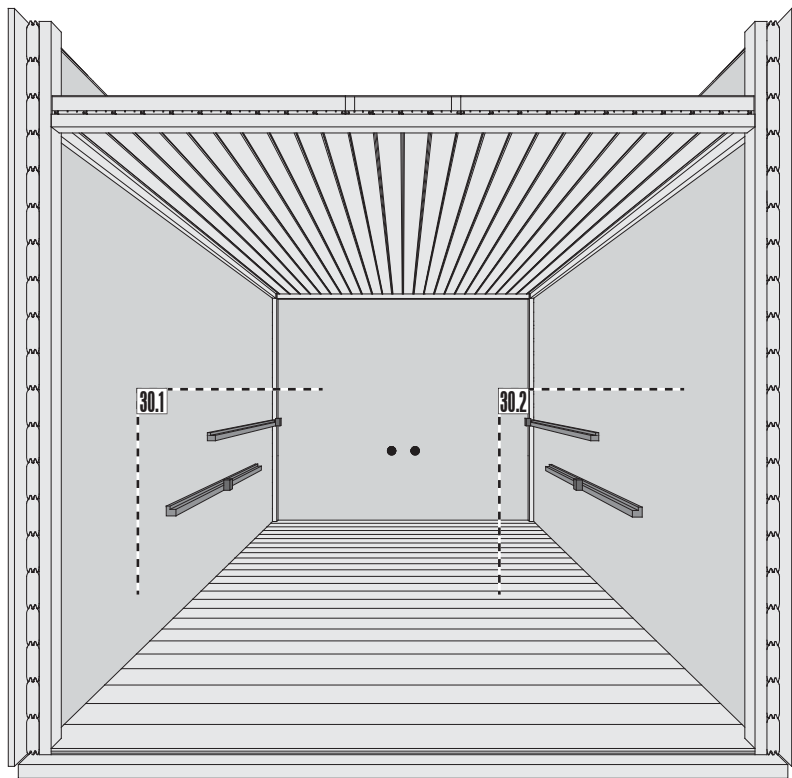

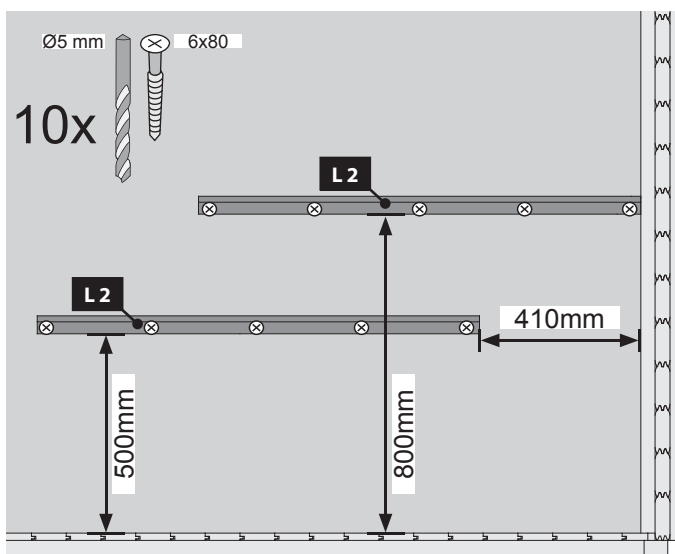

### 30.1



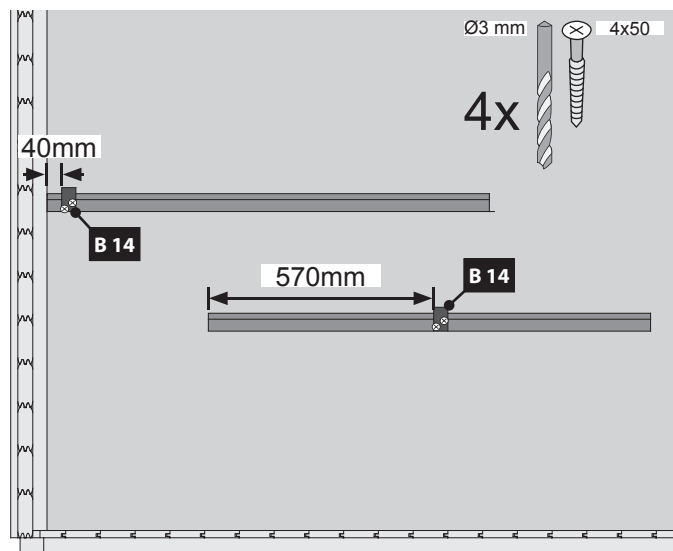
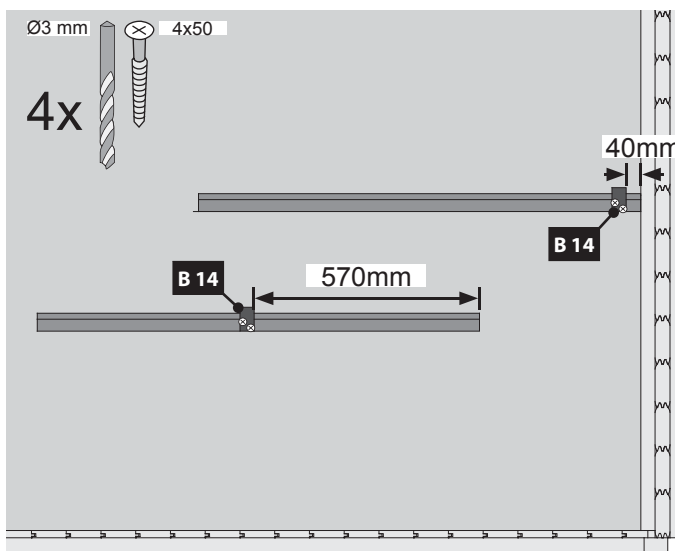
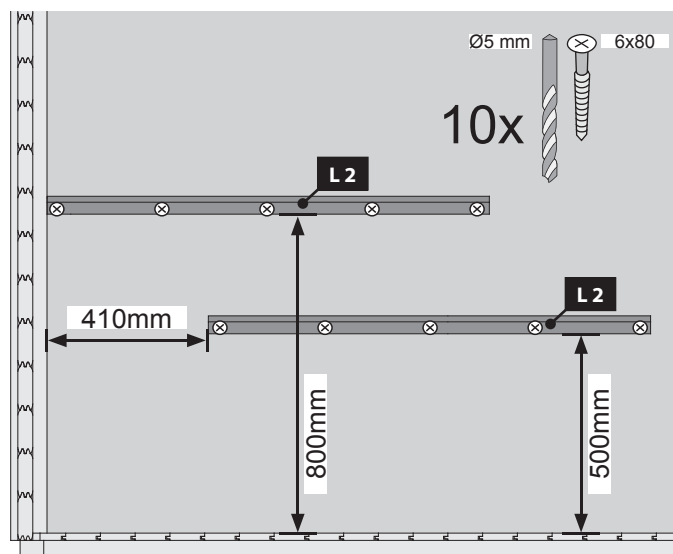

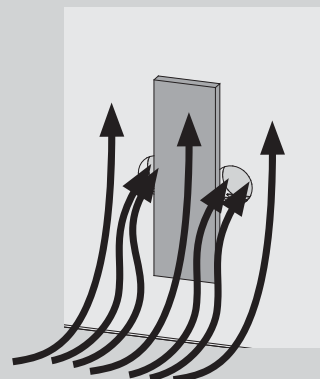
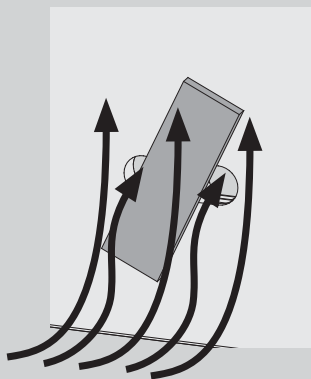
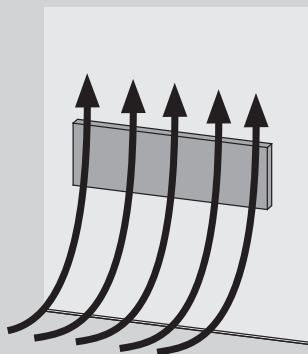
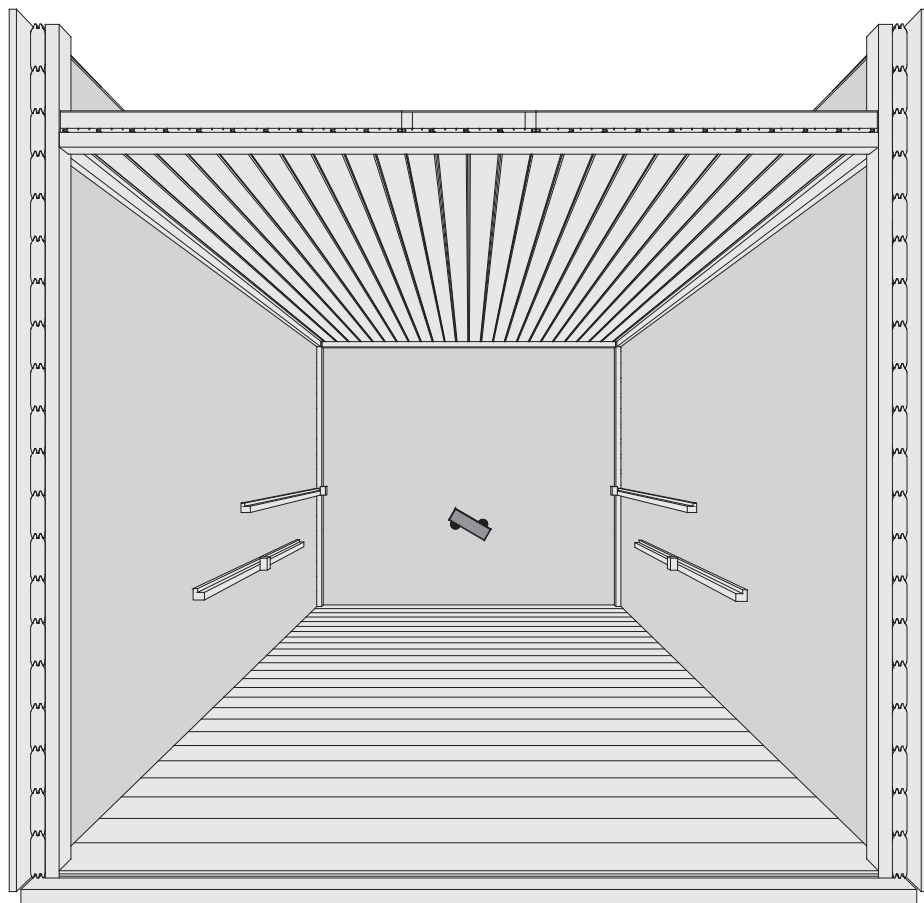
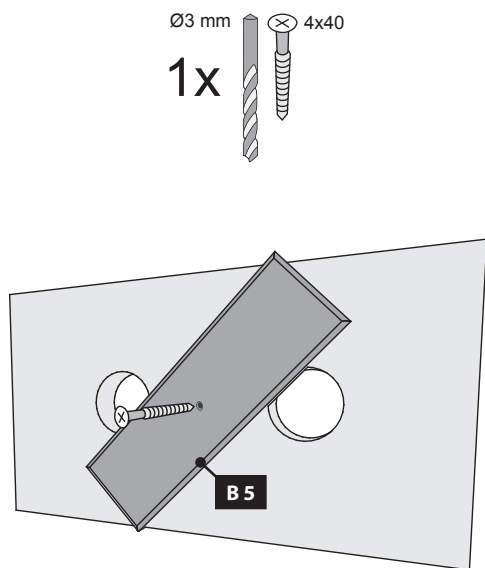
### 30.2







 Hier ist die Funktionsweise des Brettes abgebildet. Regeln Sie damit die Abluft nach Ihren eigenen Wünschen.

 Ceci représente le mode de fonctionnement de la planche. Avec elle, réglez l'écoulement de l'air selon vos désirs.

 This figure shows the functional principle of the board. Regulate the exhaust air according to your own wishes.

 Hier is de werking van het plankje afgebeeld. Regel daarmee de luchtafvoer naar eigen wens.

 Aquí está representada la forma de funcionamiento de la tabla. Regule con ello el aire de salida según sus propios deseos.

 Viene illustrato il principio di funzionamento della tavoletta di regolazione della ventilazione. Con essa si può regolare a piacere la ventilazione.

 Zde je zobrazená funkce desky. Regulujte s ní odsávací vzduch dle Vašeho přání.

 Sådant fungerer styret. Brug den til at regulere udstødningsluften efter dine egne ønsker.

32 2x

Ø3 mm 4x50  
5x

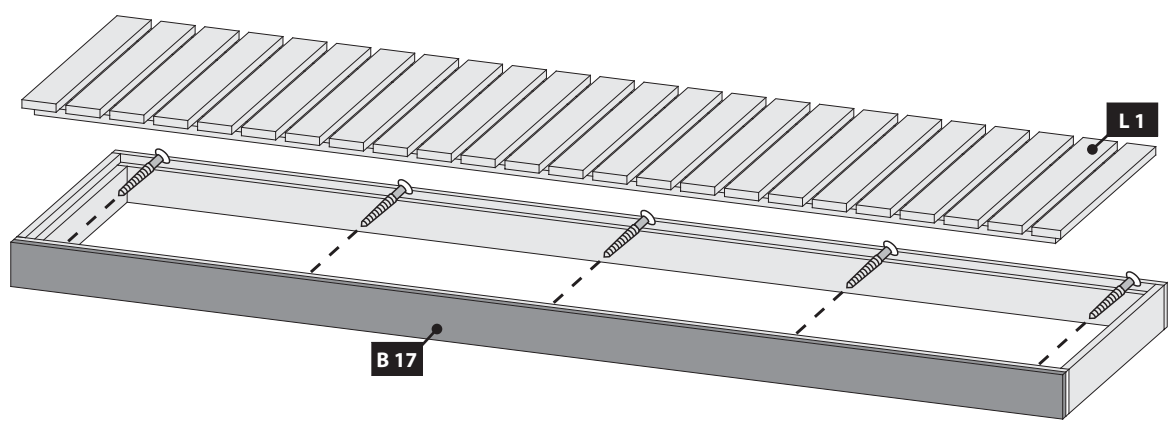
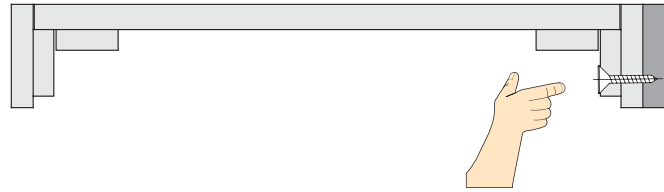

33

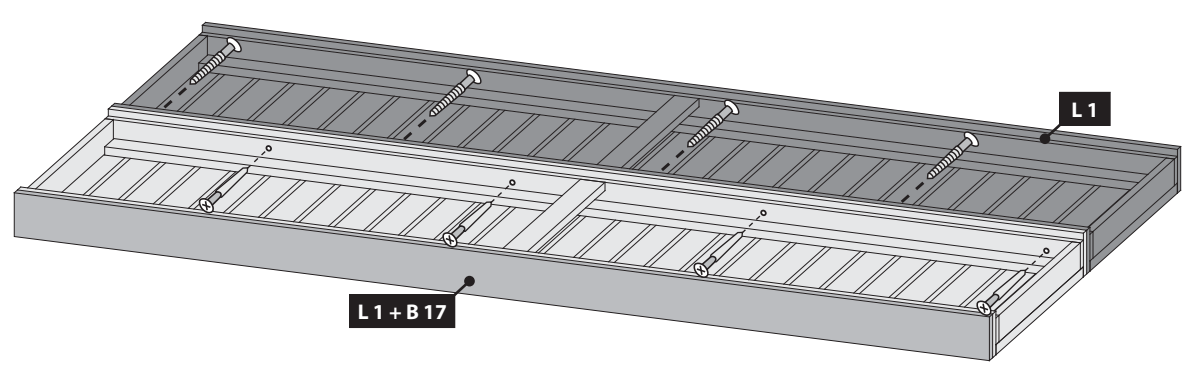
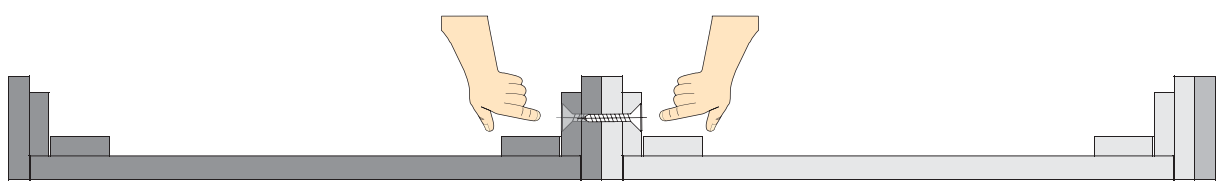

Ø3 mm 4x50  
8x

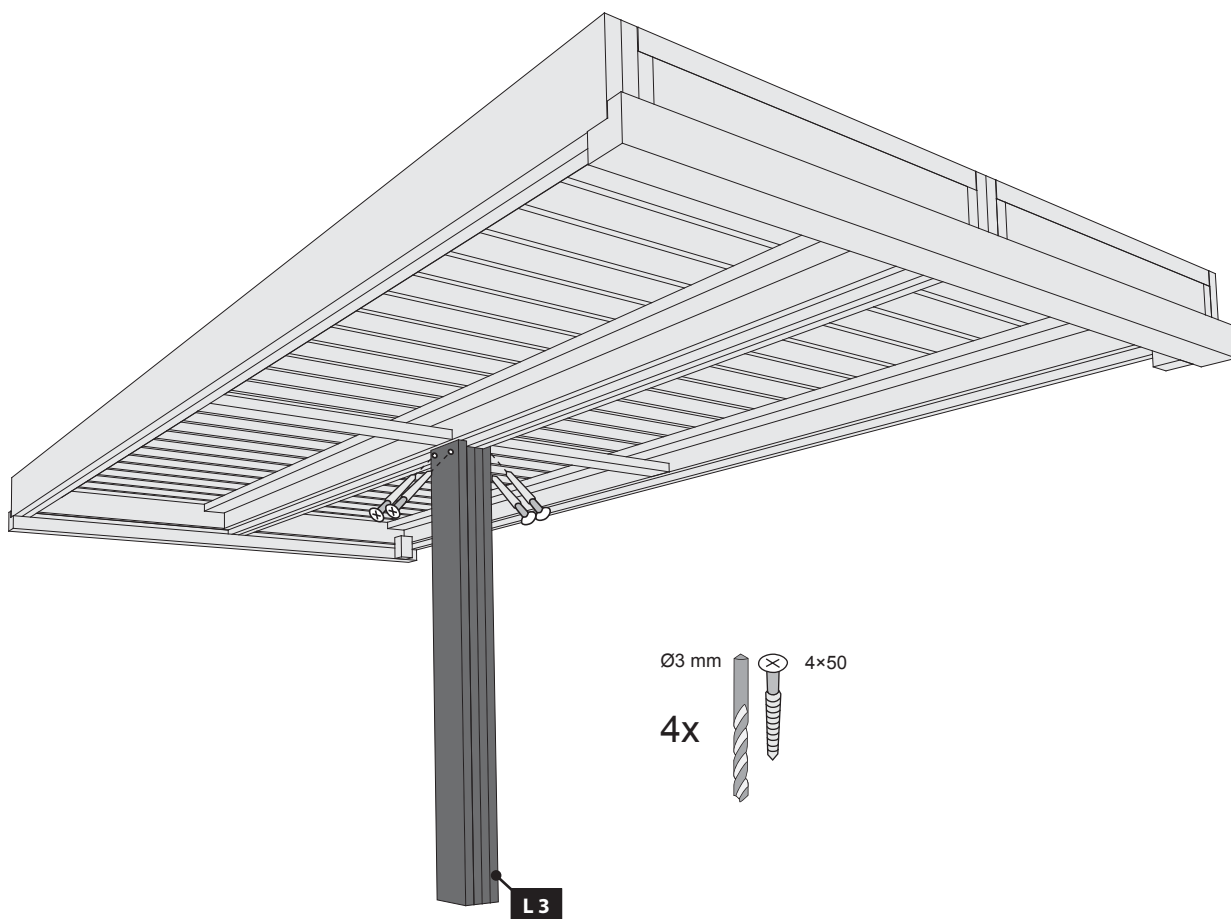
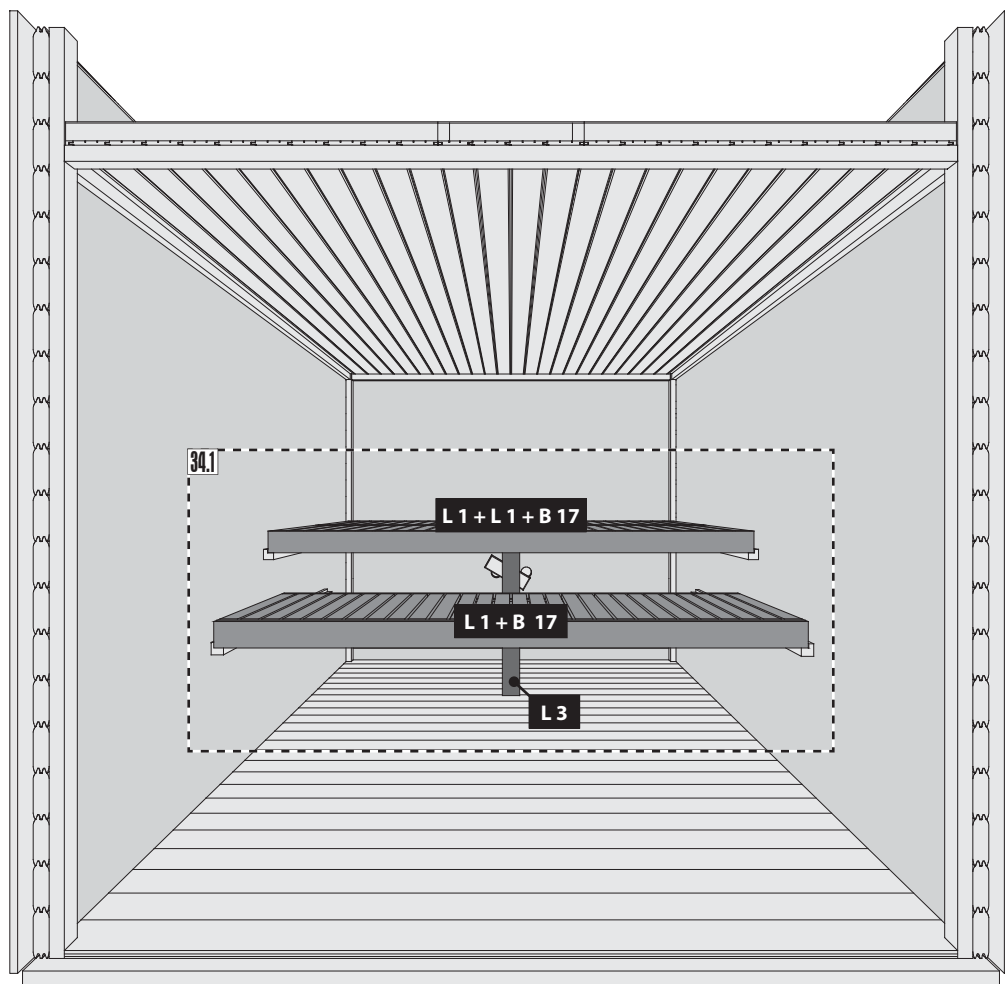



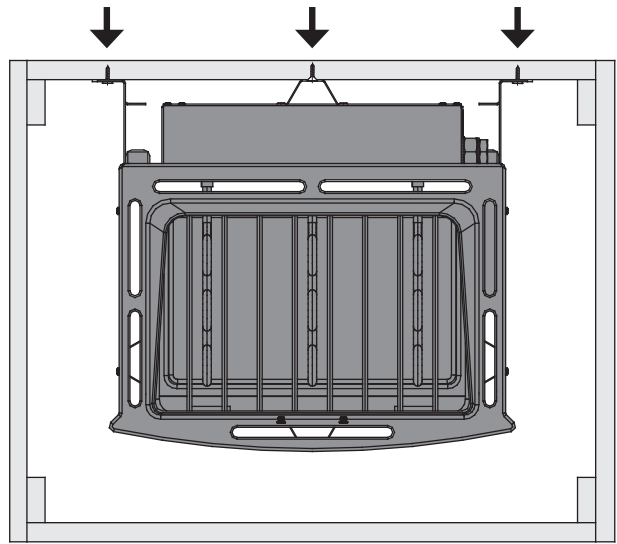
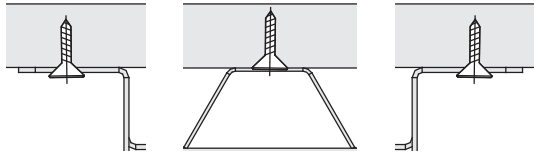



-  Ofenbefestigung
-  oven vaststelling
-  oven fixing
-  fixation four
-  fijación horno
-  fissaggio forno
-  upevňovací trouba
-  ovn fastsættelse



-  Einbau Tür
-  Installation door
-  Porte d'installation

-  Installatie deur
-  Installationsdør
-  Puerta de instalación

-  Porta di installazione
-  Montážní dveře

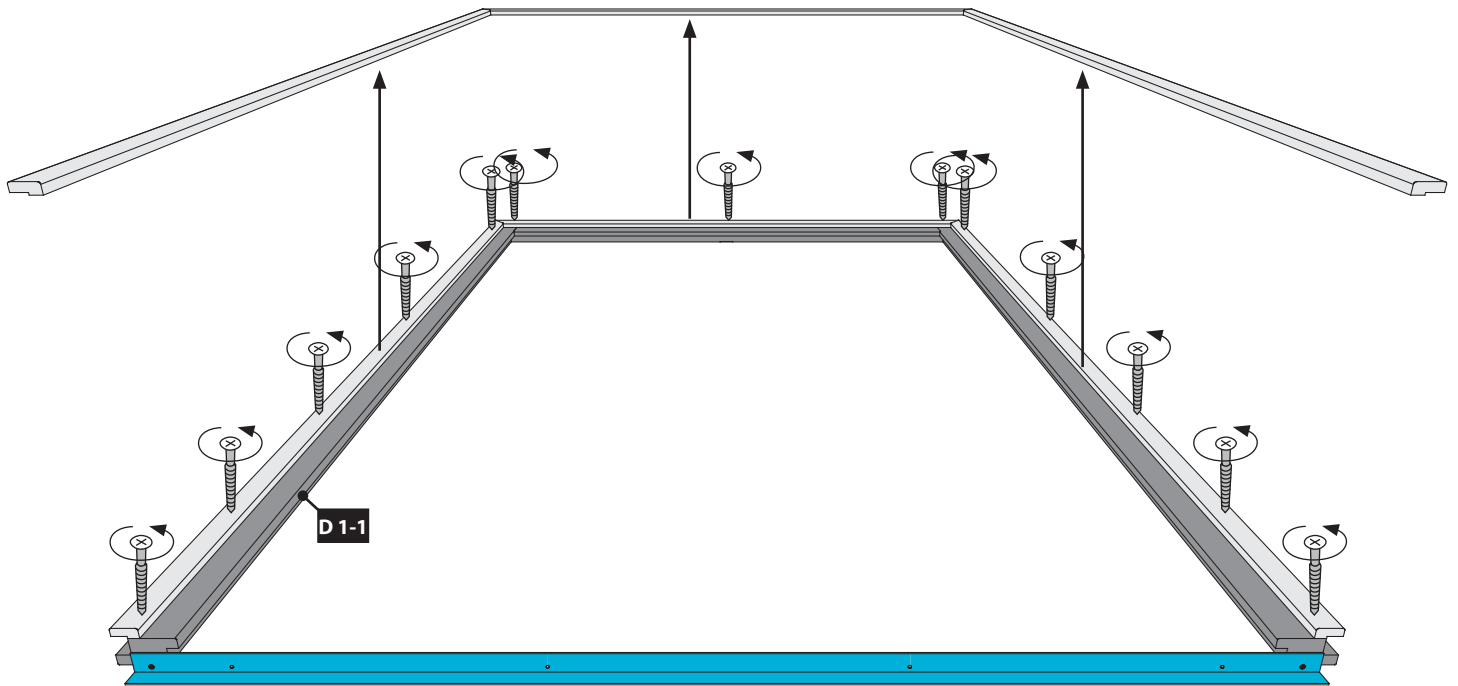

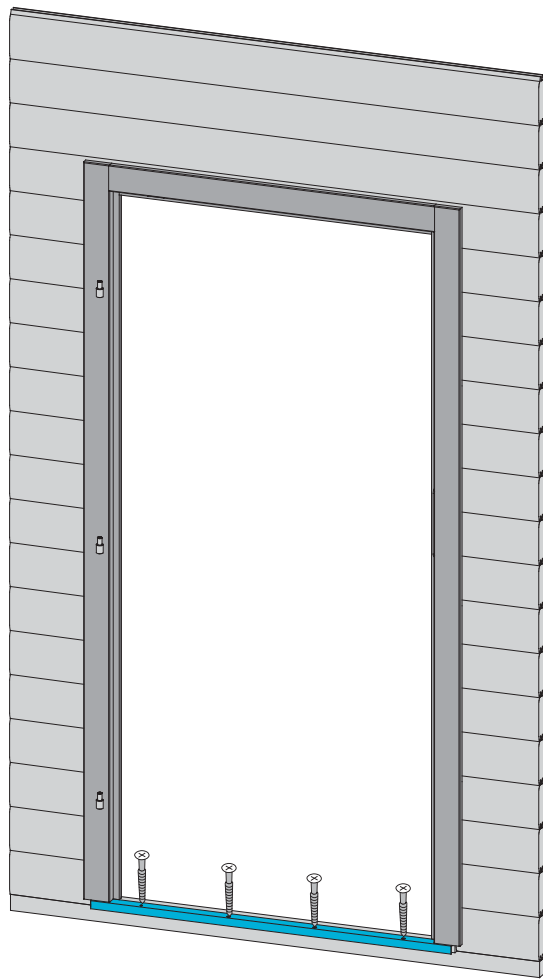
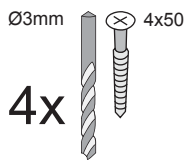

-  außen
-  outside
-  à l'extérieur
-  buiten
-  fuera
-  al di fuori
-  vně

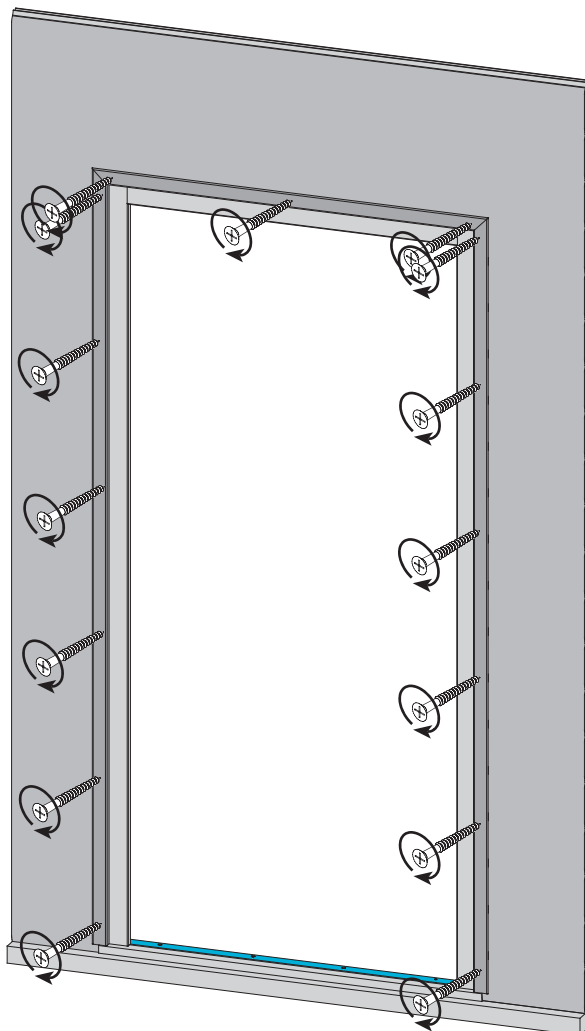

-  innen
-  Inside
-  à l'intérieur
-  binnen
-  dentro
-  dentro
-  uvnitř

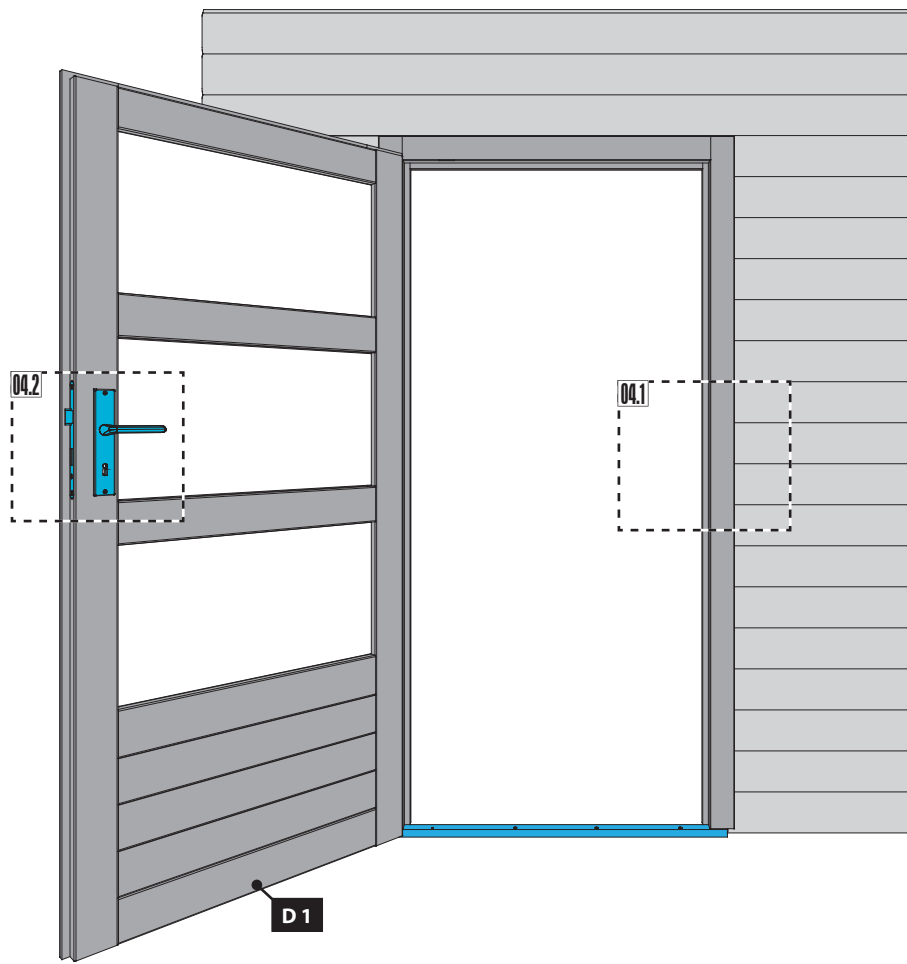

04.1

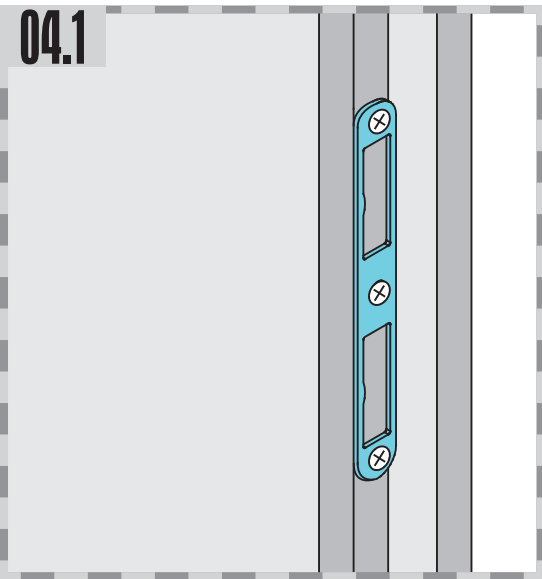

04.2-1

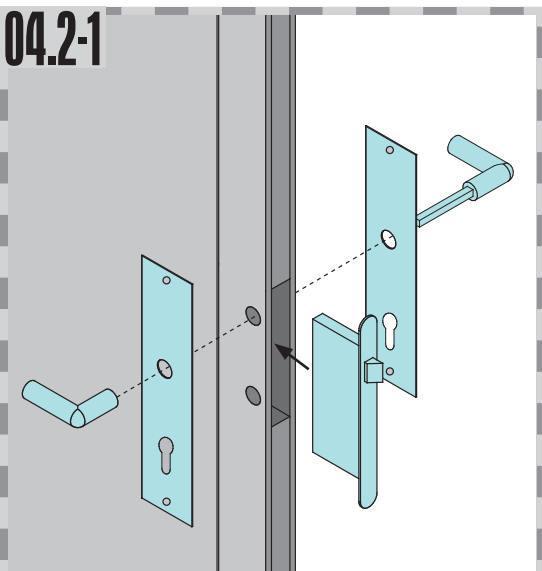

04.2-2

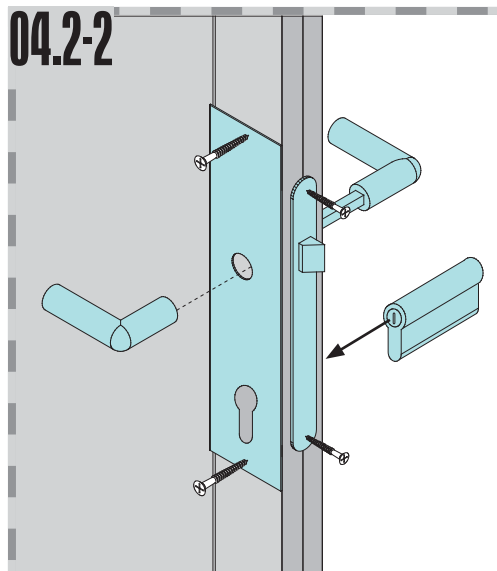

04.2-3

