

# SCHIEBETÜRSYSTEM 120 GLAS SOFTEINZUG 1-FLG.

## A: SICHERHEITSHINWEISE

SAFETY ADVICES

## B: MONTAGE, PFLEGE UND WARTUNG

ASSEMBLY, CARE INSTRUCTIONS, SERVICE AND MAINTENANCE

### Passende Schiebetürsysteme / matching sliding door systems

Art. No.: .. 403 05 01 ..  
          .. 403 05 02 ..  
          .. 403 11 01 ..  
          .. 403 11 02 ..

A

### Sicherheitshinweise:

D

**Wichtige Sicherheitshinweise für die Montage und Nutzung von Schiebetürsystemen**  
(Zusätzlich zu Montage- und Bedienungsanleitung zu beachten, um Schäden an Produkt sowie Personen- und Sachschäden zu vermeiden.)

**Wichtig:** Alle Nutzer sind über die sie betreffenden Punkte der nachfolgenden Hinweise sowie die Hinweise aus Montage- bzw. Bedienungsanleitung zu informieren!

#### **Allgemein:**

- Schiebetüren dürfen nicht zu hart zu- oder aufgezogen werden. Dies trifft vor allem auf Schiebetüren ohne Softeinzug zu.

#### **Montage:**

- Mitgeliefertes Befestigungsmaterial ist auf Kompatibilität mit den vorhandenen Untergründen zu prüfen. Gegebenenfalls muss geeignetes Befestigungsmaterial selbst besorgt werden.
- Vor der Montage müssen die Klemmflächen mit fettlösenden Haushaltsmitteln von Fetten befreit werden.
- Es besteht die Gefahr von Quetschungen beim Heben der Tür. Entsprechend ist erforderliche Schutzkleidung zu tragen.

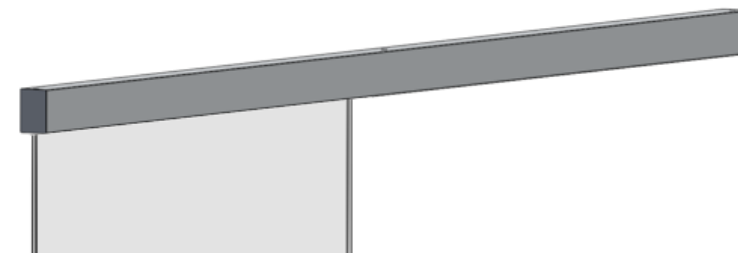

### Safety advices:

GB

**Important safety-related information for the mounting and use of sliding door systems**  
(Follow these instructions in addition to the mounting and operating instructions in order to avoid damage of product and damage to person or property.)

**Important:** All users have to be informed about relevant points mentioned in following safety advices and installation and operating instructions!

#### **General information:**

- Do not shut sliding doors with excessive force. This is especially important on sliding doors without soft closing device.

#### **Assembly:**

- Included mounting material must be checked for compatibility with the existing wall and ceiling. If required, suitable mounting material must be purchased.
- Clean clamping areas with fat solvent (standard commercial cleaning agent) before mounting.
- There is a danger of bruising when lifting the door. Wearing protective clothing is required.

# SCHIEBETÜRSYSTEM 120 GLAS SOFTEINZUG 1-FLG.

Bis Standardtürhöhe 2058mm:  
-> min. Glastürbreite 750mm

Türhöhe 2058mm - 2200mm:  
-> min. Glastürbreite 810mm

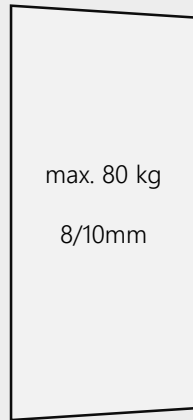

Klemm- und Klebebereiche reinigen  
*clean clamping and adhesive areas*

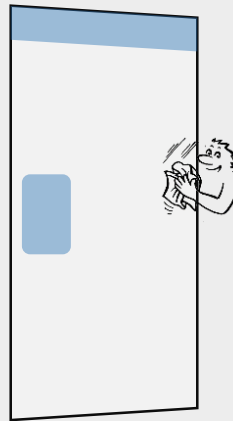

Scheibe ist vor Beschädigung zu schützen  
*glass must be protected from damage*

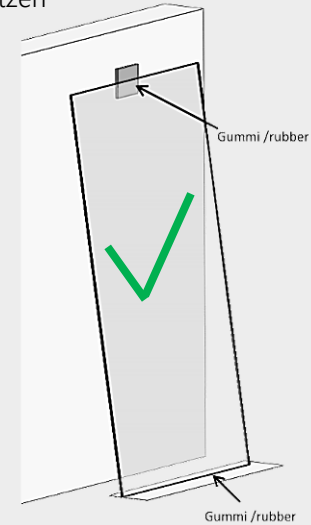
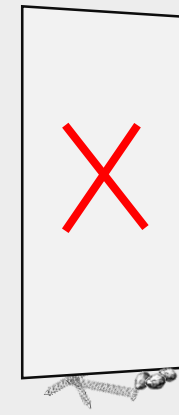
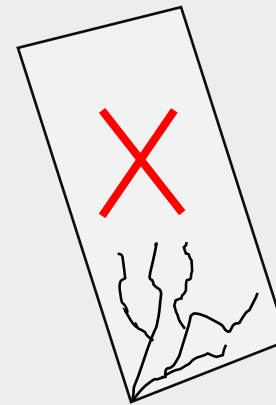

Up to standard door height 2058mm:  
-> min. glass door width 750mm

Door height 2058mm - 2200mm:  
-> min. glass door width 810mm

**B**

## Montage, Pflege und Wartung

### **Wichtige Informationen:**

- Maximal zulässiges Gewicht der Tür liegt bei 80kg.
- Vor der Montage Glasflächen mit handelsüblichem Glasreiniger (ohne Oberflächenversiegelung) im Bereich der Klemmflächen reinigen.
- Keine Verdünnung verwenden.
- Mitgeliefertes Befestigungsmaterial ist auf Kompatibilität zu den vorhandenen Untergründen zu prüfen. Gegebenenfalls muss geeignetes Befestigungsmaterial selbst besorgt werden.

### **Wartung:**

- Der Sitz und die Gängigkeit der geklemmten Teile sowie die Justierung der Tür müssen regelmäßig kontrolliert werden. Insbesondere im Falle von hochfrequentierten Anlagen sollte die Prüfung von einem Fach- oder Installationsbetrieb erfolgen. Beschädigte Glaselemente (Abplatzungen und/oder Ausmuschelungen) müssen unverzüglich ausgetauscht werden!
- Die Reinigung der Metall-Oberflächen (z.B. Griffe, Schiene) darf nur mit geeigneten Reinigern und Pflegemitteln erfolgen.

## Assembly, care instructions, service and maintenance

### **Important information:**

- Maximum permissible weight of the door is 80 kg.
- All glass clamping areas have to be cleaned with standard glass cleaning products (without surface sealing) prior to installation
- Do not use thinners
- Included mounting material must be checked for compatibility with the existing wall and ceiling. If needed suitable mounting material must be purchased.

### **Maintenance:**

- Check clamped parts at regular intervals for proper positioning, smooth running and the door for correct adjustment. Especially highly frequented door systems require inspection by properly qualified staff (specialized companies or installation firms). Immediately replace damaged glass elements (glass flaking and/or conchoidal fractures)!
- Only use suitable cleaning and care products to clean the metallic surfaces (e.g. handles, rail).

# SCHIEBETÜRSYSTEM 120 GLAS SOFTEINZUG 1-FLG.

## Pflege allgemein:

Die Oberflächen der Schiebetürsysteme sind nicht wartungsfrei und sollten gemäß ihrer Ausführung gereinigt werden.

- Für metallische Oberflächen (Eloxal-/Edelstahlfläche) bitte nur geeignete Reiniger ohne Scheuermittelanteil verwenden.
- Für lackierte Oberflächen bitte nur entsprechende lösemittelfreie Reiniger verwenden.

## General care instructions:

The surface finishes of the sliding door systems are not maintenance-free and should be cleaned according to their material and texture.

- For metallic surfaces (anodized/stainless steel finish) please only use appropriate cleaning agents without abrasive additives.
- For varnished surfaces please only use appropriate solvent-free cleaning agents.

## Lieferumfang / scope of delivery

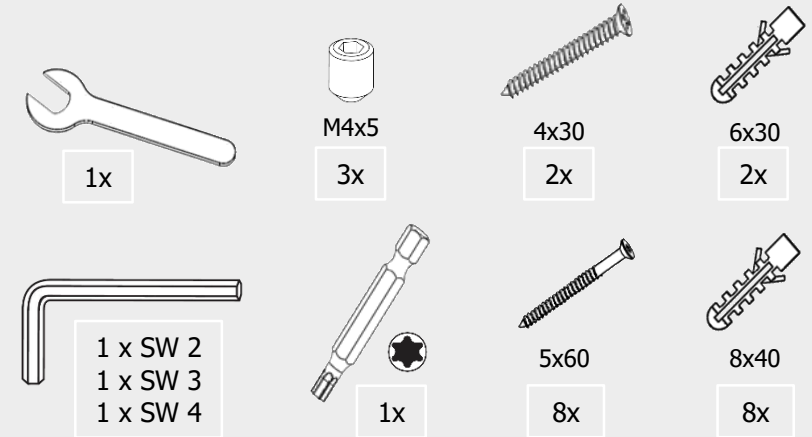
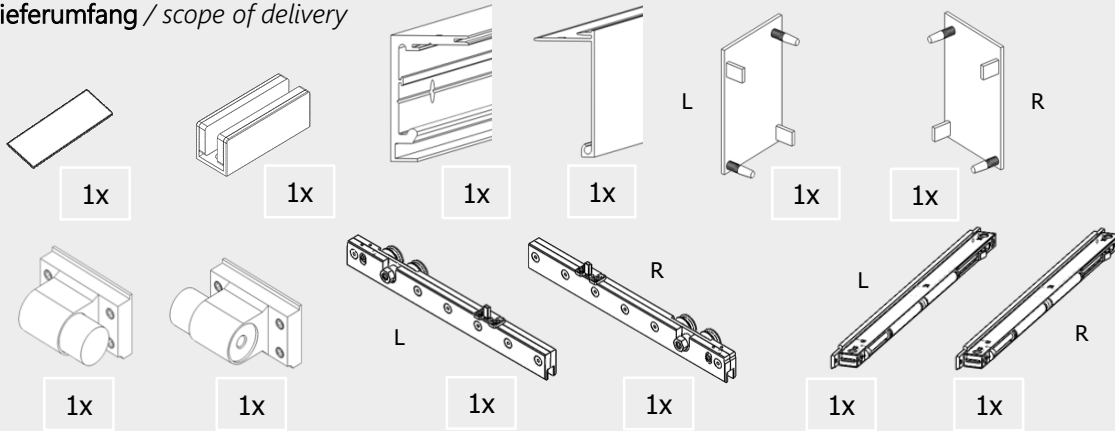

## Montagewerkzeuge (nicht im Lieferumfang) / assembly tools (not included)

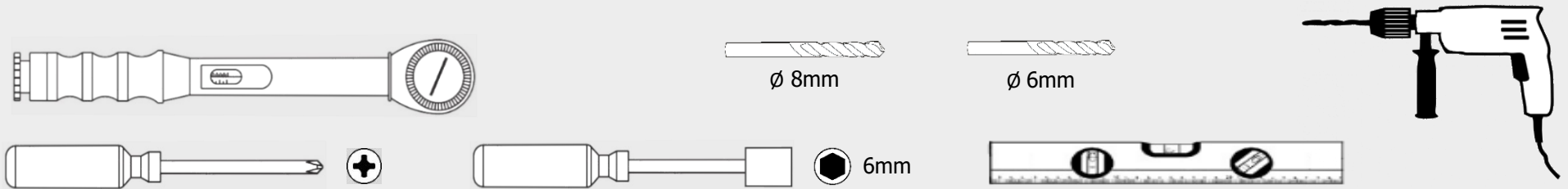

# SCHIEBETÜRSYSTEM 120 GLAS SOFTEINZUG 1-FLG.



Für 10mm Glastüren bitte beiliegenden Adapter verwenden.  
For 10mm glass doors please use enclosed adapter.

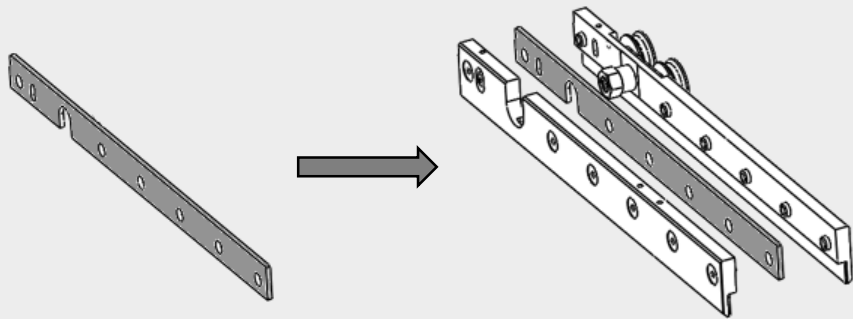

Adapter für 12mm Glastüren ist optional erhältlich.  
Adapter for 12mm glass doors is optionally available.

## Montage Softeinzug-Aktivator / mounting soft stop activator

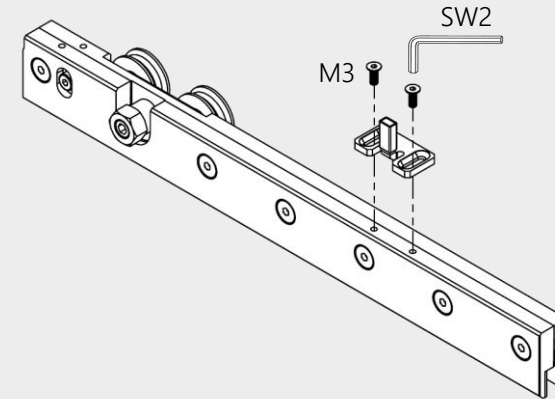

Wandabstand kann mit optional erhältlichen Abstandsprofilen erweitert werden.  
Wall distance can be extended with optionally available spacer profiles.

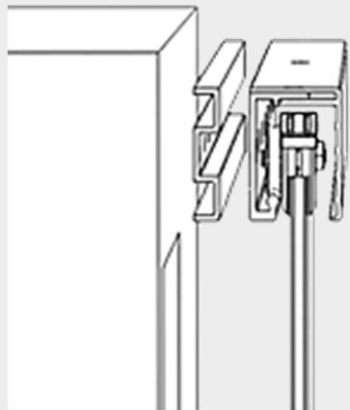

ohne Abstandsprofil  
without spacer profil

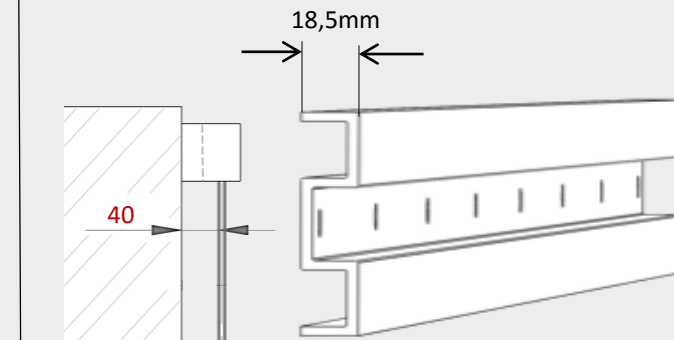
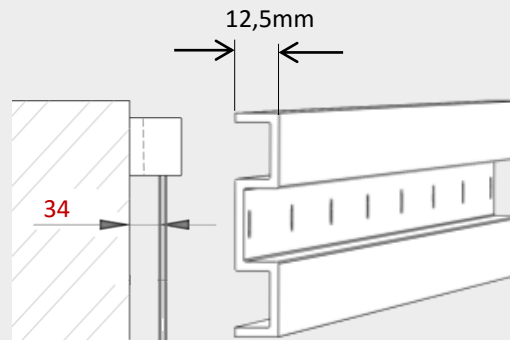
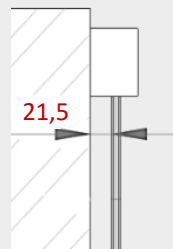

# Schiebetürsystem 120 GLAS SOFTEINZUG 1-FLG.

## Wandbefestigung / wall mounting

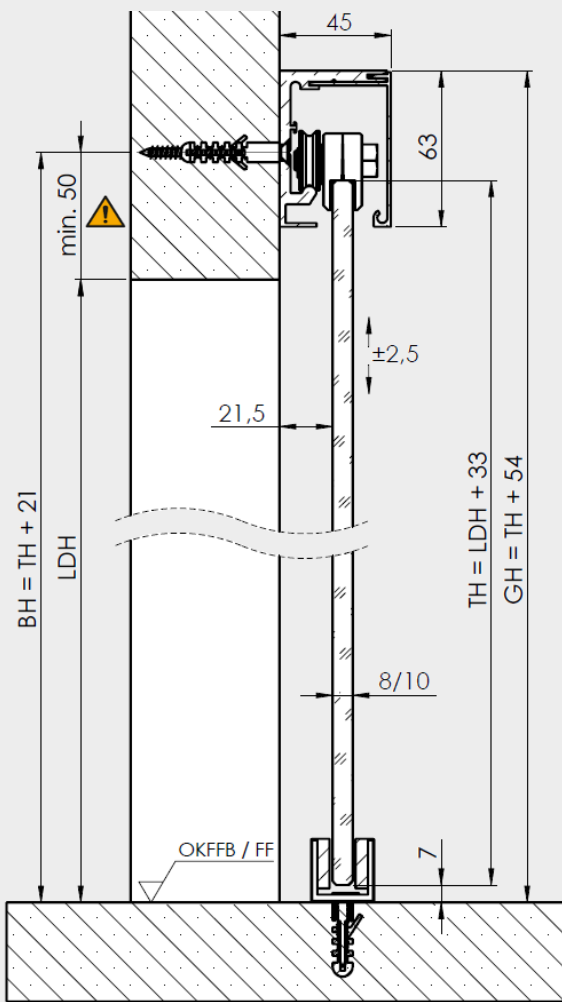

- BH = Bohrhöhe /drilling level
- GH = Gesamthöhe /total height
- TH = Türhöhe /door height
- LDH = Lichte Durchgangshöhe /pass line height
- LDB = Lichte Durchgangsbreite /pass line width

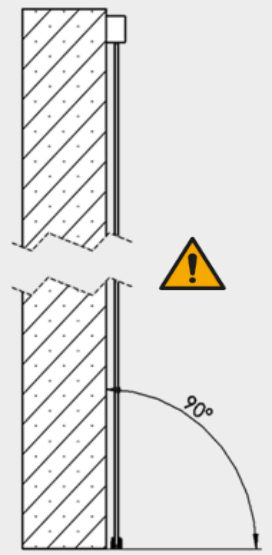

Glasüberstand: 30mm empfohlen  
Glass overlap: 30mm recommended



1

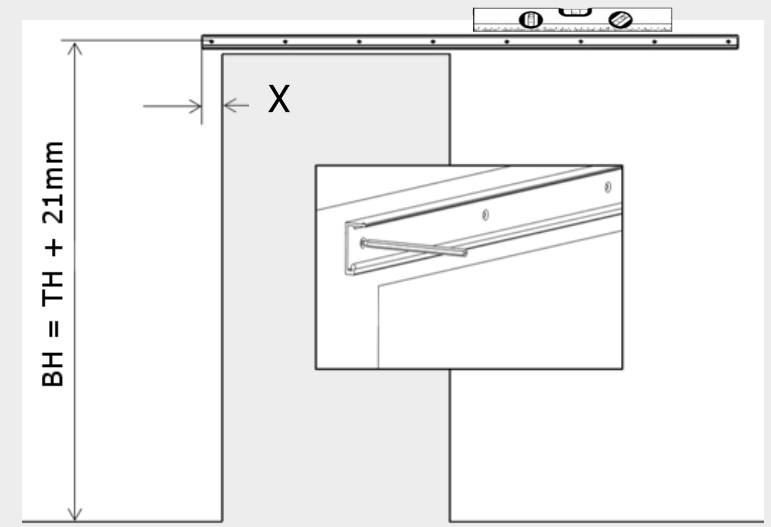

X = Glasüberstand / glass overlap + 1mm  
Empfohlen / recommended: X = 31mm

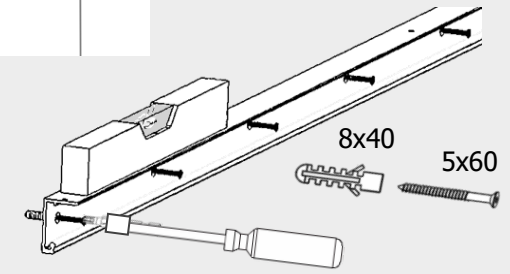
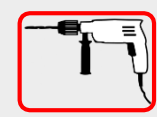
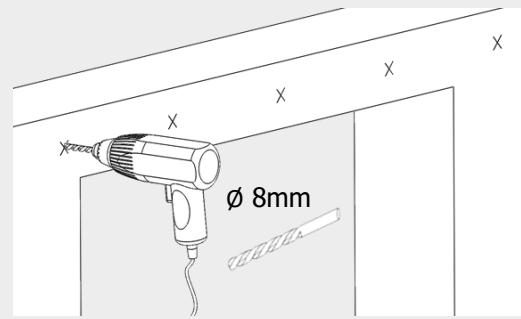

# SCHIEBETÜRSYSTEM 120 GLAS SOFTEINZUG 1-FLG.

## Deckenbefestigung / ceiling mounting

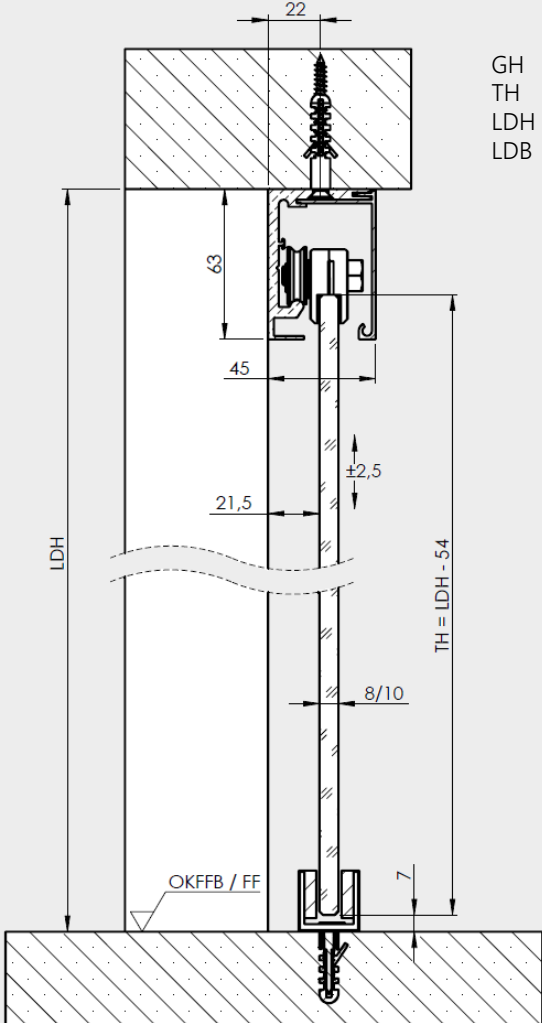

GH = Gesamthöhe / total height  
 TH = Türhöhe / door height  
 LDH = Lichte Durchgangshöhe / pass line height  
 LDB = Lichte Durchgangsbreite / pass line width

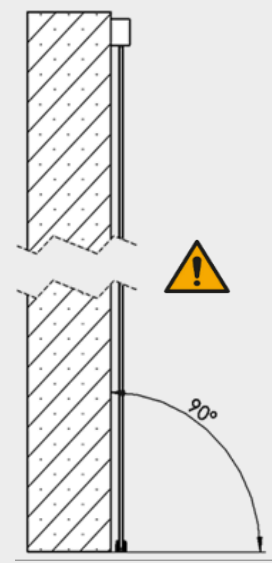

Glasüberstand: 30mm empfohlen  
 Glass overlap: 30mm recommended

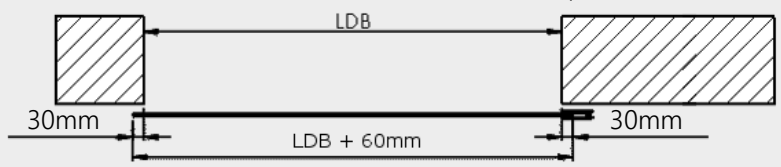

1

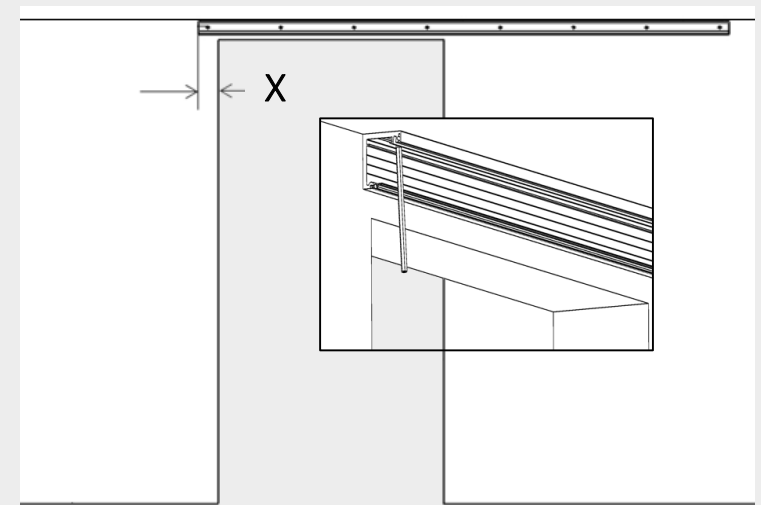

X = Glasüberstand / glass overlap + 1mm  
 Empfohlen / recommended: X = 31mm

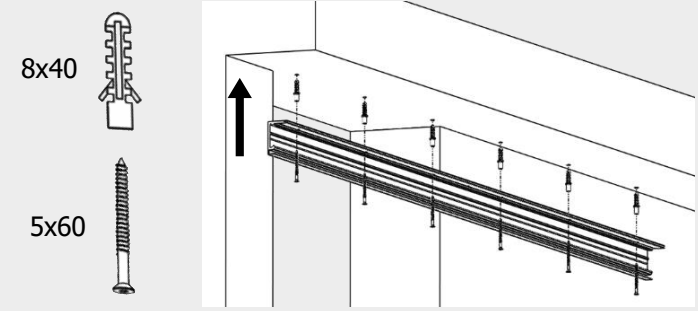
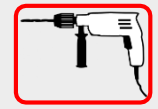
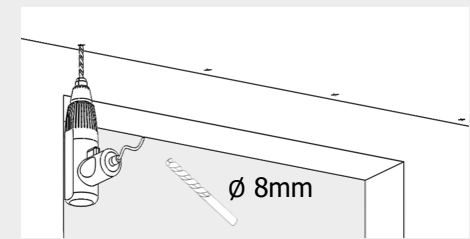

# SCHIEBETÜRSYSTEM 120 GLAS SOFTEINZUG 1-FLG.

**2**

Schraube der Aushängesicherung lösen und nach unten schieben.

*Loosen the screw of the safety catch slightly and slide it downwards.*

SW3

40 L R 40

SW 3

6 – 8 Nm

**3**

Für 10mm Glastür müssen die beiliegenden Gleitpads verwendet werden.  
*For 10mm glass door the included sliding pads must be used.*

10mm

2X 10mm

1 2 3 4

**4**

25,5mm bei 8mm Glas, 26,5mm bei 10mm Glas.  
 Ggf. zusätzlich das Maß des Abstandsprofils addieren.

*25,5mm for 8mm glass, 26,5mm for 10mm glass.  
 If applicable, add thickness of spacer profile.*

**X = 25,5mm / 26,5mm**

47,5

**Unsere Empfehlung:** Bohren & Schrauben  
*Our recommendation:* drill & screw

**Alternative:** Kleben / bonding

**A**

saubern / clean

**B**

1 2 3 4 5 6

andrücken / pressing on  
 -> ca. 30s

Aufkleber nicht geeignet für: Parkett, Teppich, Nassräume und unebene Oberfläche.  
*Stickers not suitable for: parquet, carpet, wetrooms and uneven surfaces.*

Ø6mm

# SCHIEBETÜRSYSTEM 120 GLAS SOFTEINZUG 1-FLG.

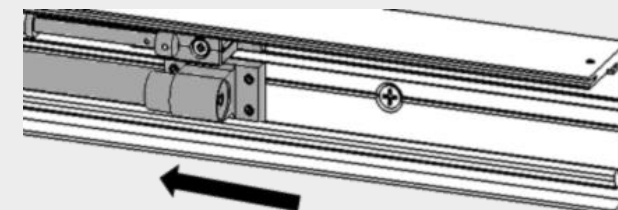
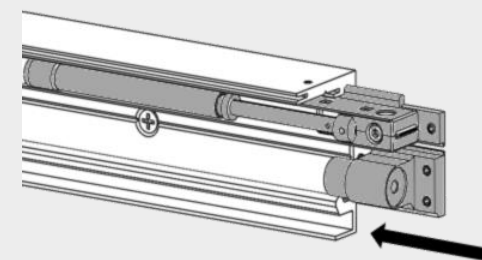
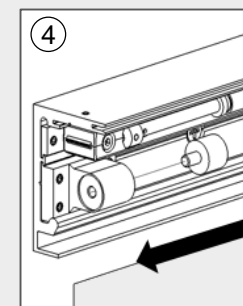
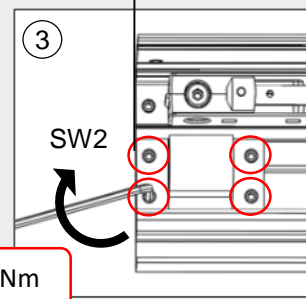
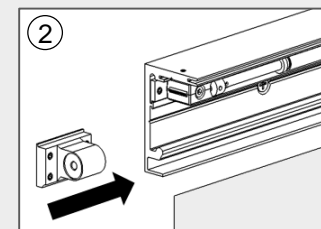
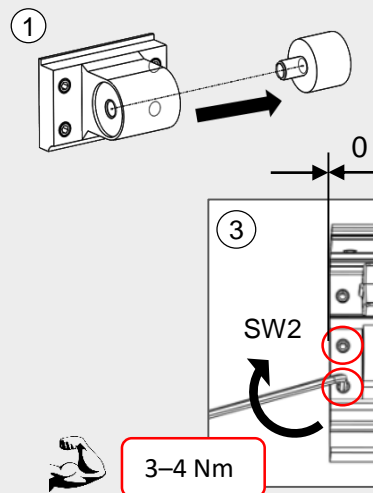
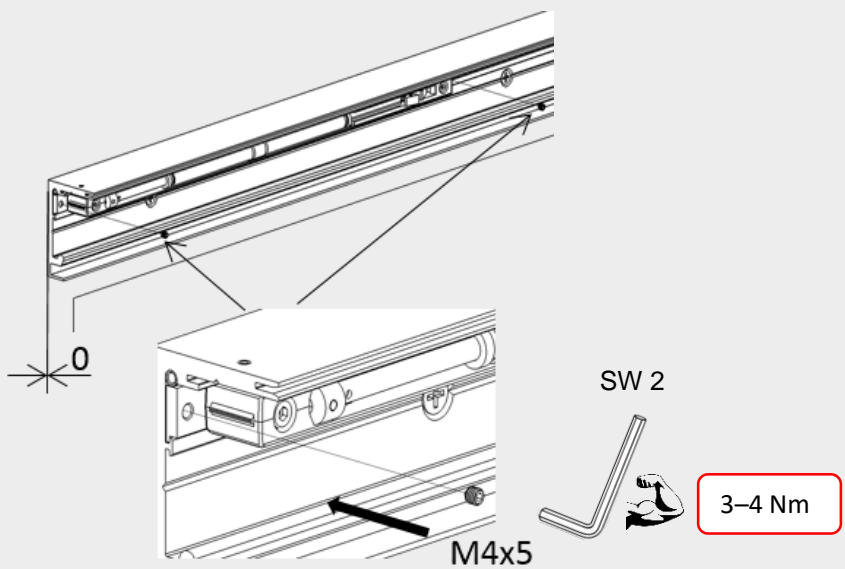
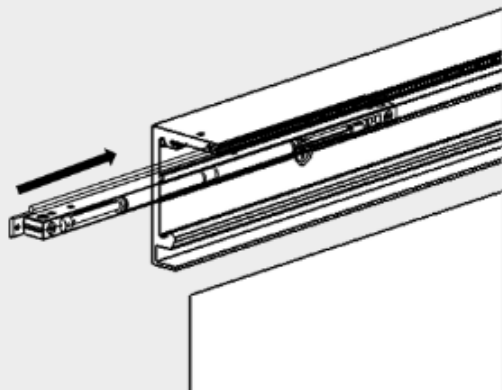



# SCHIEBETÜRSYSTEM 120 GLAS SOFTEINZUG 1-FLG.

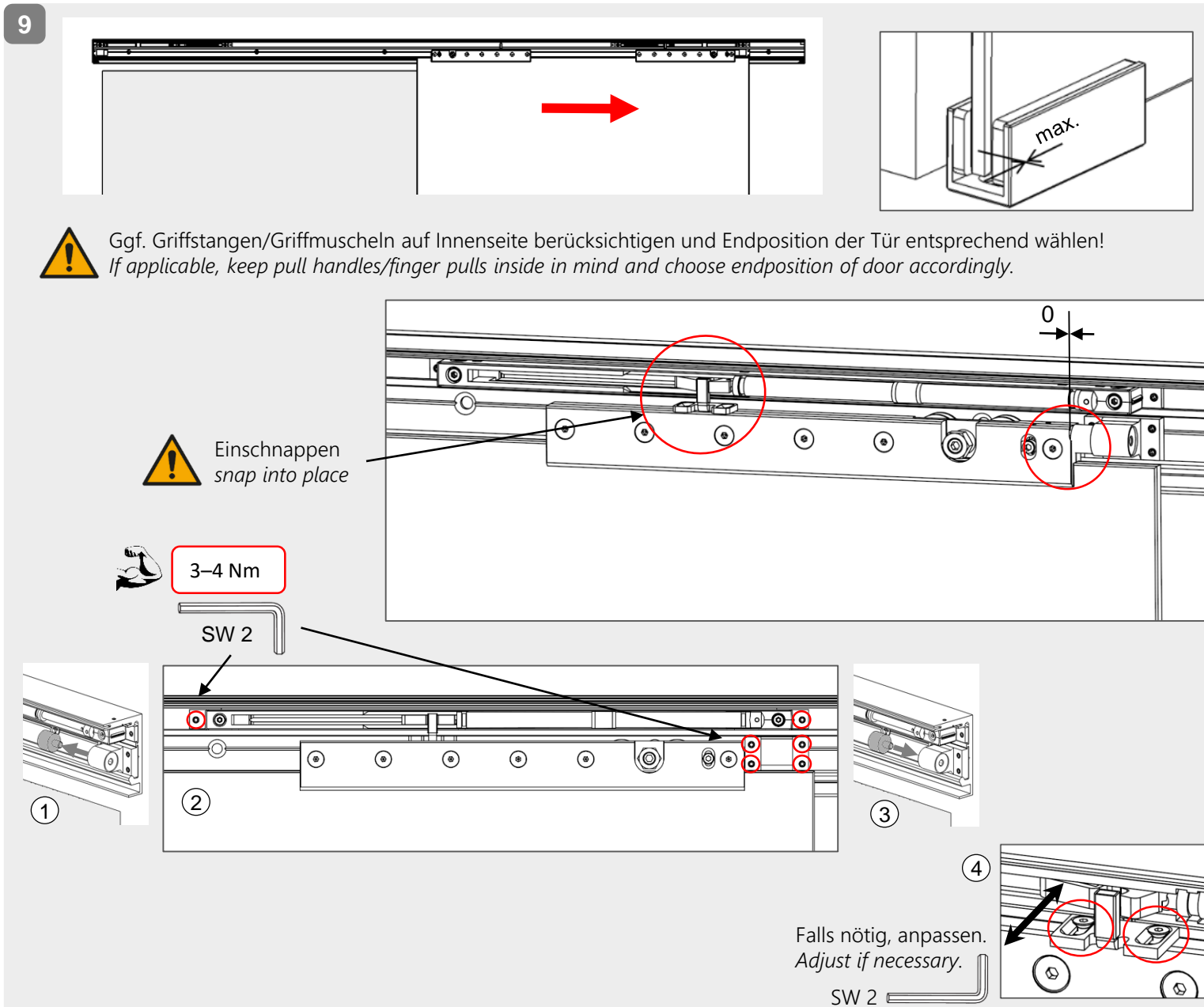
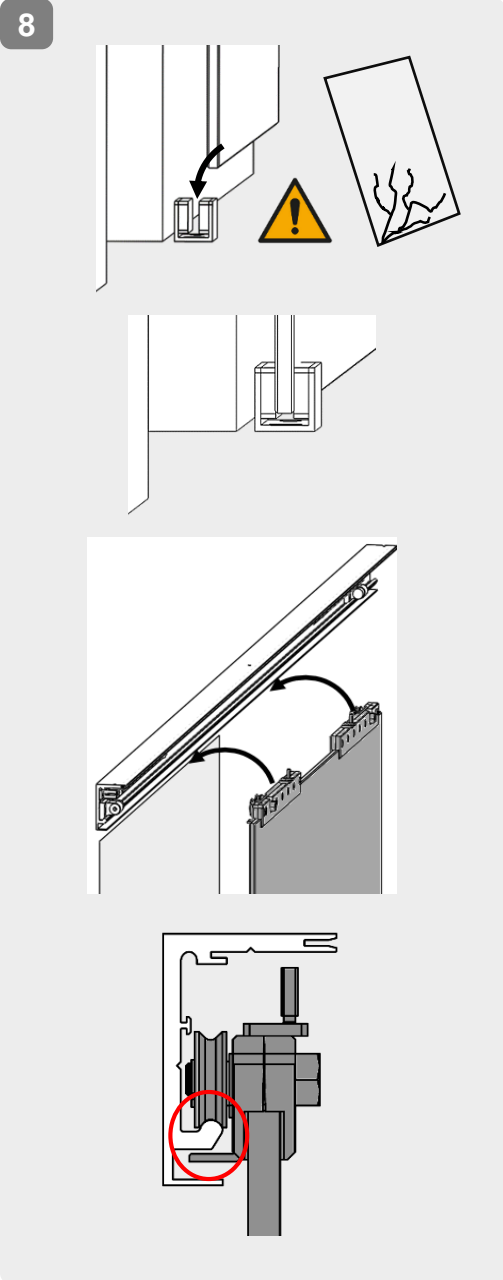

# SCHIEBETÜRSYSTEM 120 GLAS SOFTEINZUG 1-FLG.

## 10 Höheneinstellung height adjustment

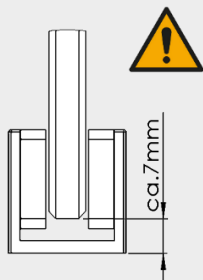
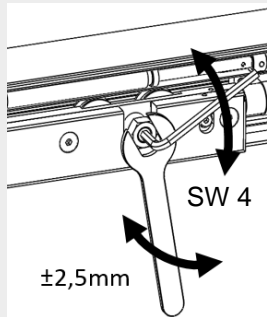
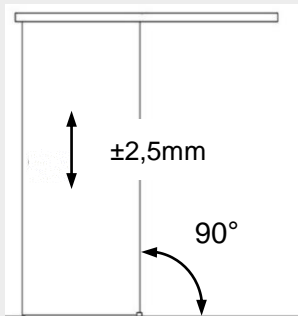

## 11 Aushebesicherung / safety catch

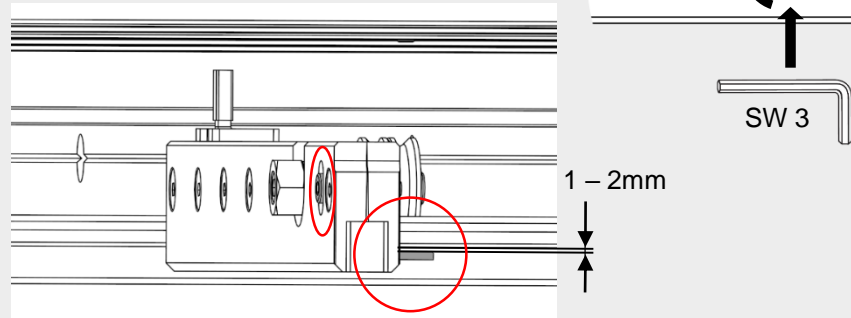

Abstand der Aushebesicherung zum Aluprofil auf 1-2mm einstellen und festziehen.  
*Adjust the distance of the safety catch to the aluminum profile on 1-2mm and tighten it.*

## 12

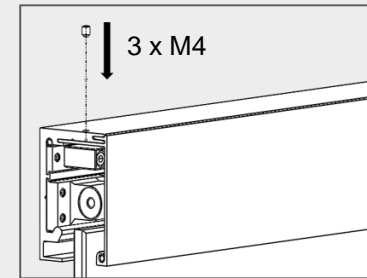
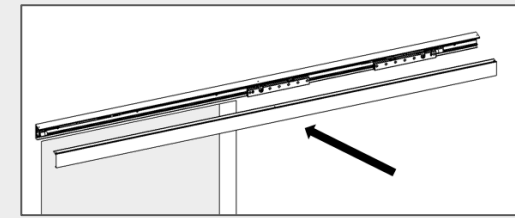

Wandbefestigung / wall mounting

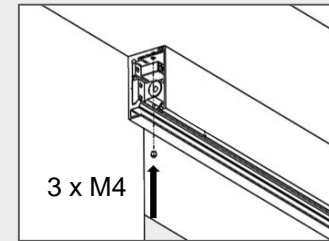

Deckenbefestigung / ceiling mounting

## 13

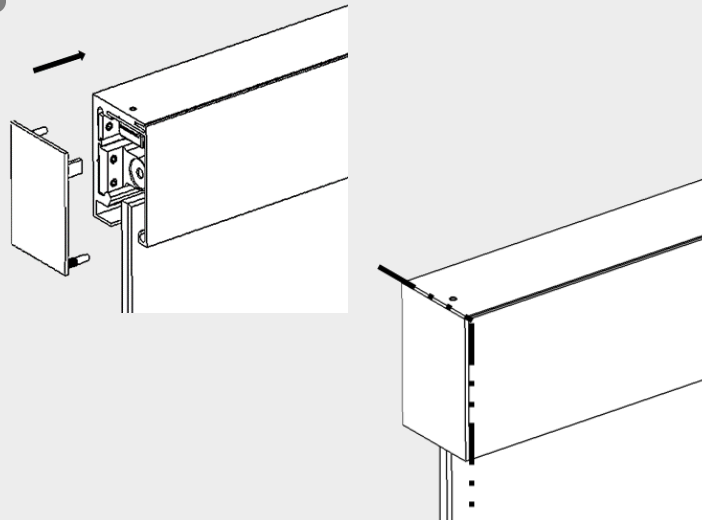

## 14

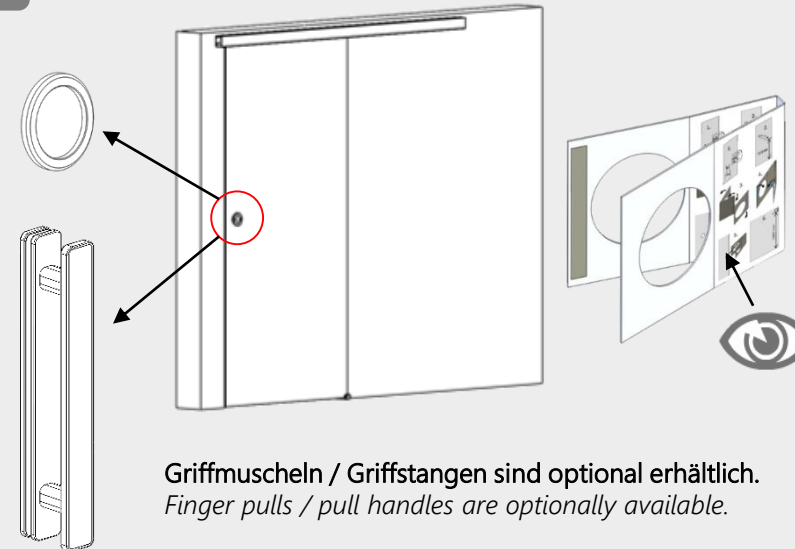

Griffmuscheln / Griffstangen sind optional erhältlich.  
*Finger pulls / pull handles are optionally available.*