

Technische Daten



Spiegelverkehrte Montage möglich.

Artikelnummer:

871 480

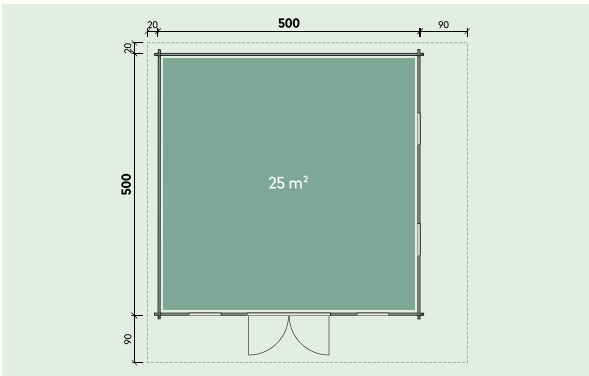



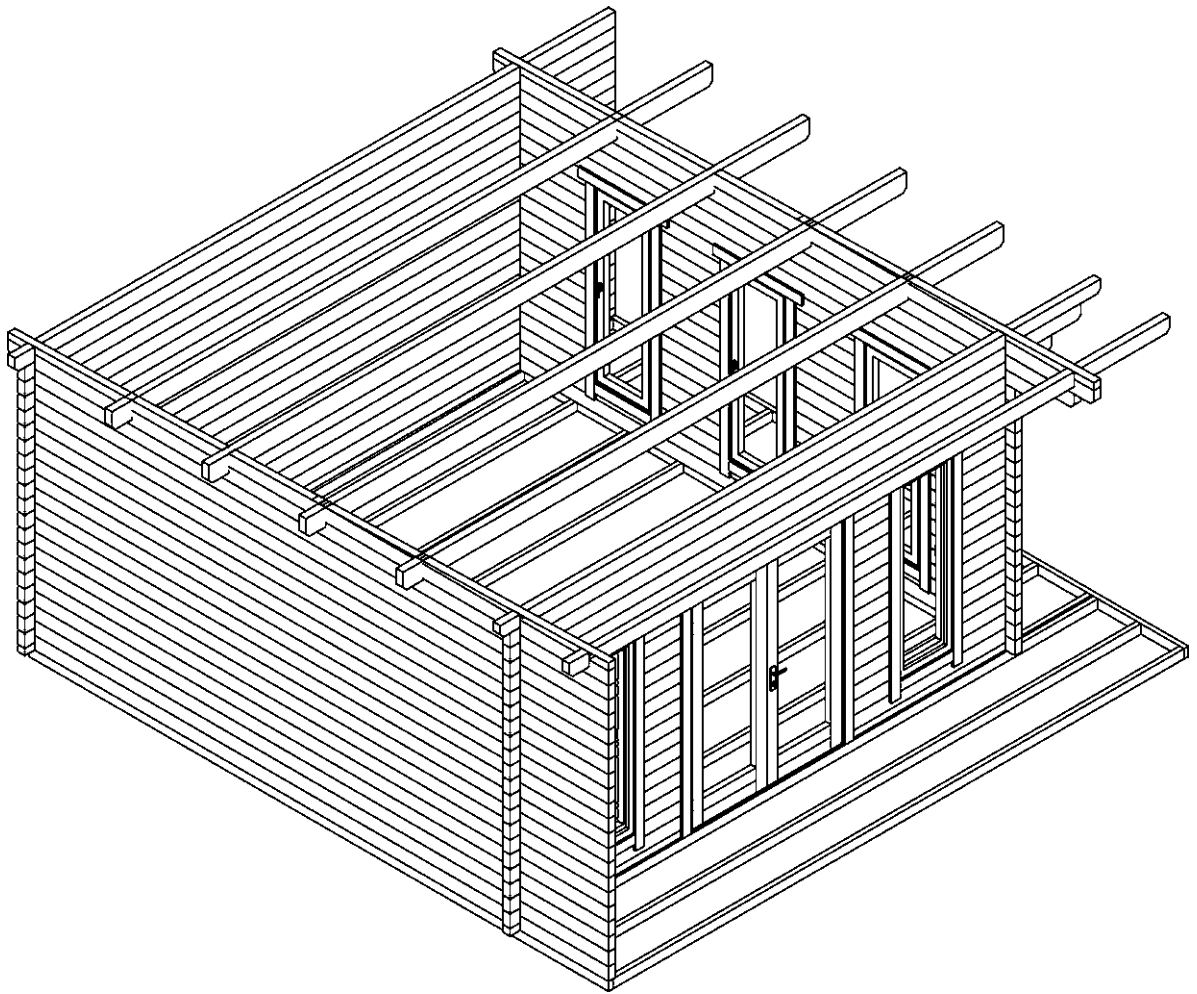

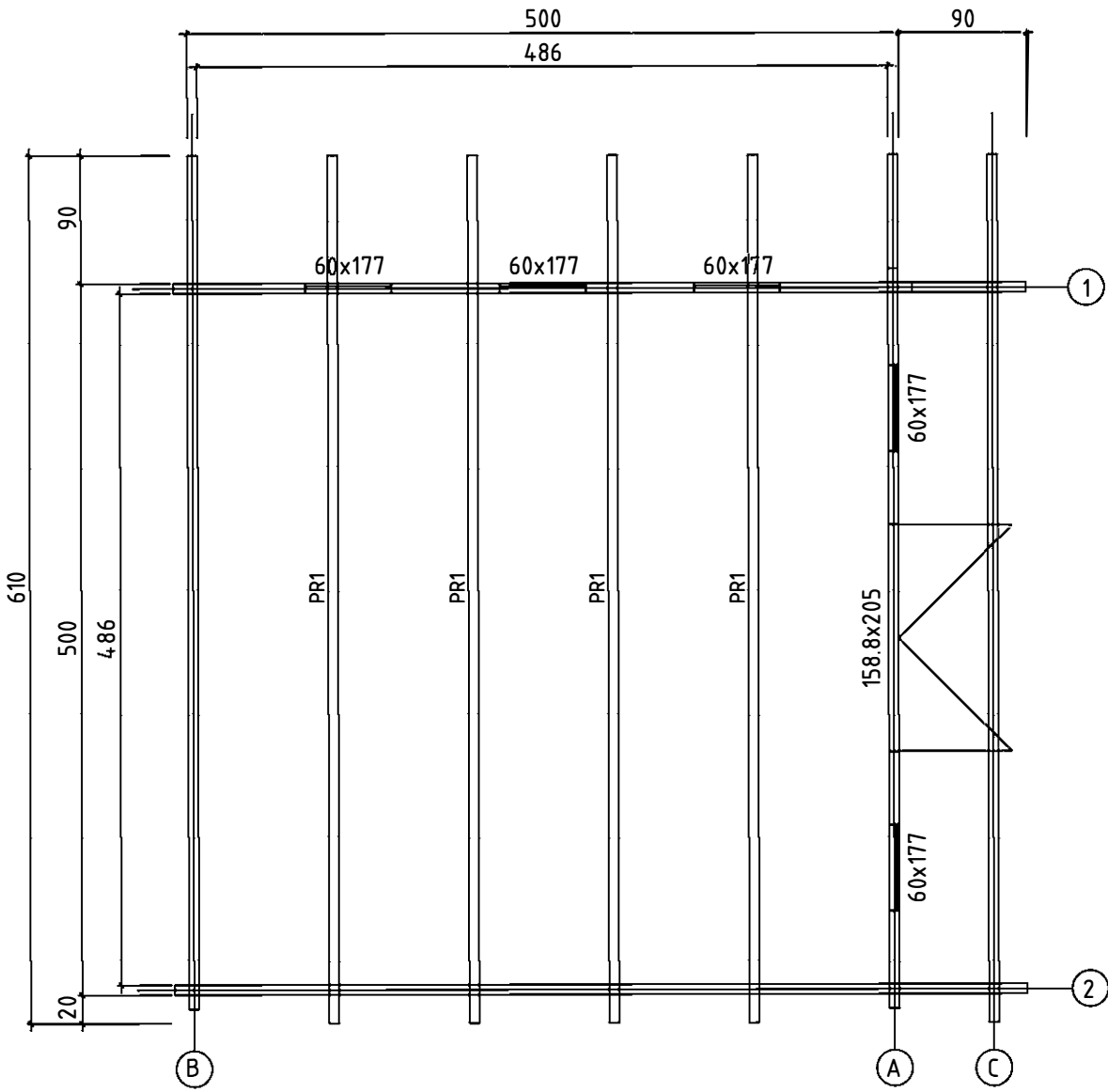
Kontrolliert durch:



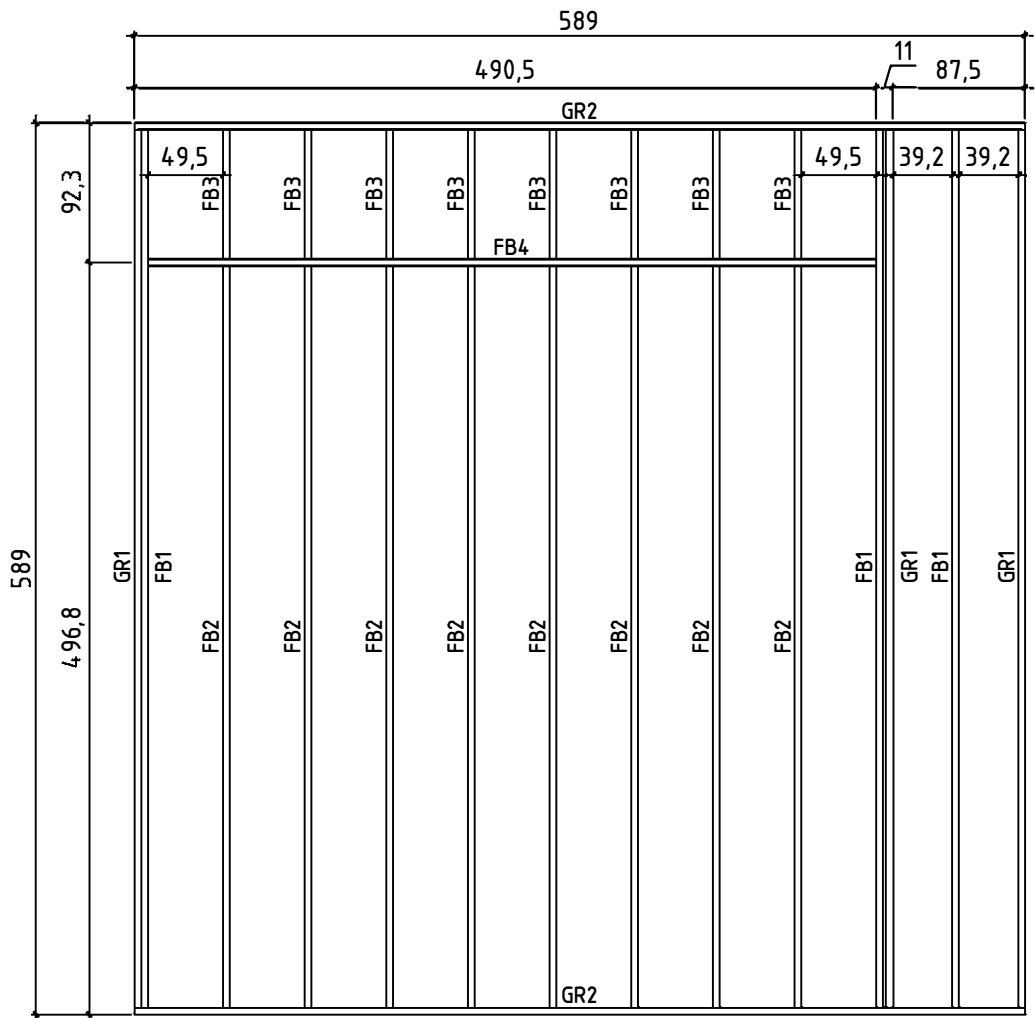

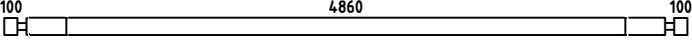
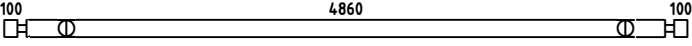
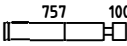
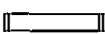
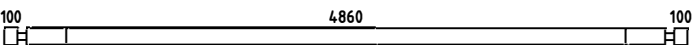
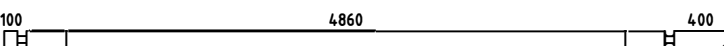
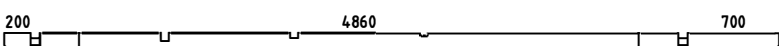
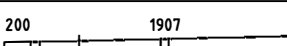
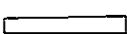
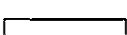
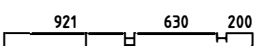
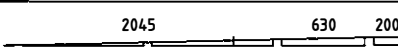
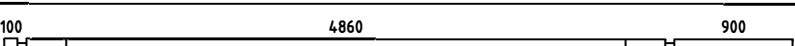
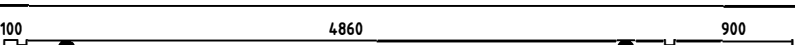
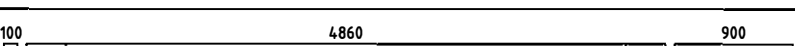

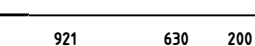
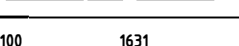
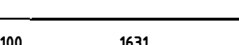
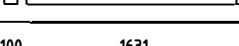

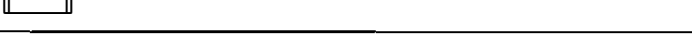
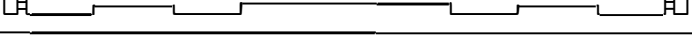
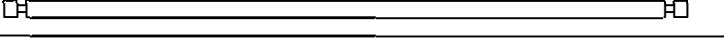

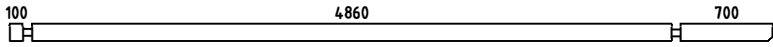
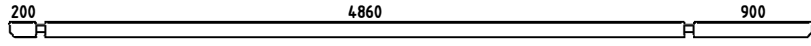
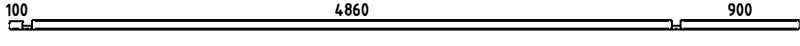
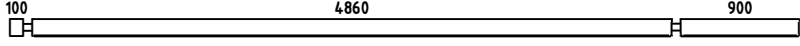
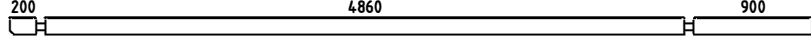
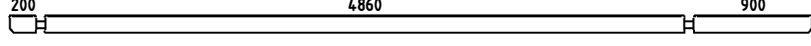

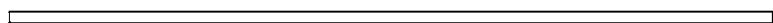
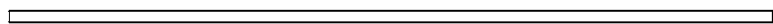
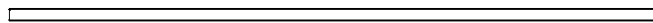
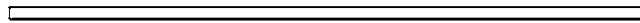
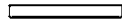
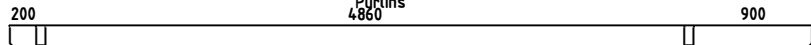
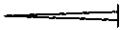







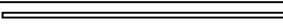









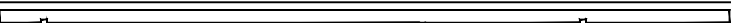



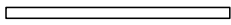

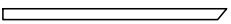

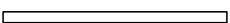
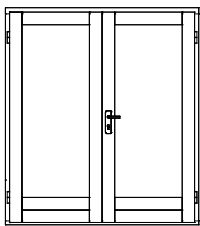
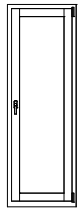

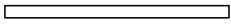
Wir empfehlen als Fundament für Ihr Gartenhaus eine vollflächig festgegründete, gepflasterte oder betonierte Fläche. Wahlweise ist auch ein Punkt- oder Streifenfundament möglich.

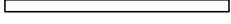

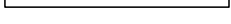
Pos		Quantity	Profil (mm)	Lenght (mm)
001		1	70x130	5200
002		1	70x130	5200
003		28	70x130	928
004		28	70x130	758
005		2	70x130	5200
006		1	70x130	5500
007		1	70x130	5900
008		2	70x109	2177
009		2	70x130	926
010		2	70x130	926
011		1	70x130	1891
012		2	70x70	3015
013		1	70x130	6000
014		1	70x130	6000
015		17	70x130	6000
016		1	70x130	6100
017		1	70x130	1891
018		2	70x65	1801
019		2	70x130	1801
020		2	70x130	1801
021		26	70x130	680
022		26	70x130	511
023		1	70x130	5200
024		2	70x130	5200
025			70x130	5500

Pos		Quantity	Profil (mm)	Lenght (mm)
026		1	70x130	5800
027		1	70x114	6100
028		1	70x65	6000
029		19	70x130	6000
030		1	70x130	6100
031		1	70x130	6100
GR2	GROUNDFRAME 	2	45x90	5890
GR1	GROUNDFRAME 	3	45x90	5800
FB1	FLOORBEAMS 	3	45x90	5800
FB2	FLOORBEAMS 	8	45x90	4900
FB4	FLOORBEAMS 	1	45x90	4815
FB3	FLOORBEAMS 	8	45x90	855
PR1	Purlins 	4	70x170	6100
	WINDOW 600x1770	5		
	DOOR 1588x2050	1		
1	Screws/Schrauben/Vis 5x100 mm- For fixing first row of wall logs /Fixierung des ersten Bohlenkranzes/Pour fixer les lamesde plancher 	6		
2	Nails/Nägel/Clous 2.5x50 - For fixing floorboards/ Befestigung Fussbodenbretter/Pour fixer les lames de plancher 	850		
3	Nails/Nägel/Clous 2.5x50 - For fixing roofboards/ Befestigung Dachbretter/Pour fixer les voliges 	500		
4	Nails/Nägel/Clous 2.5x50 - For fixing floor edge trims/ Befestigung Fussleisten/Pour fixer les plinthes du plancher 	30		
5	Nails/Nägel/Clous 2.5x50 - For fixing roofing felt fillet/ Befestigung giebelabschlussbrett/Pour fixer la latte de finition de la couverture 	40		
6	Screws/Schrauben/Vis 2,5x50 mm- For fixing roof side boards and roof edge reinforcement Befestigung Traufenbretter und Traufenleisten Pour fixer les planches de rive et le tasseau de refront 	175		
7	Screws/Schrauben/Vis 2,5x50 mm- For fixing fascia boards and diamonds/ Befestigung Giebelblende und Raute Pour fixer les planches de rive et le diamant 			
8	Screws/Schrauben/Vis 2,5x50 mm- For fixing fwindow and door trims/ Befestigung Fenster und türen/ Pour fixer les croisillons des fenetres et des portes 			
9	Metal storm Brace/Gewindestange/Tige filetee 8 mm 	4		
10	Shim,Nuts/Mutter ,U-Scheibe/Ecrou,Rondelle 8 mm For fixing storm braces/ Pour fixer les anti tempete/ Für Sturmleisten Pour fixer les croisillons des fenetres et des portes Metal storm Brace/Gewindestange/Tige filetee 8 mm KL1 M8 2,90 m 2 Screws 180 8 pcs. KL2 M8 2,81 m 2 Plastic caps 4 pcs. 	4/4		

POS	ST.	B	H	L	
FB1	Vt. spetsi				 FUNDMENTHOLZER 
F1	23,6m ²	28		4855	 FUSSBODENBRETTER
F2	4,4m ²	28		900	 TERRASSE FUSSBODENBRETTER
F3	5,2m ²	28		5830	 TERRASSE FUSSBODENBRETTER
PR	4	70	170	6100	 DACHBALKEN 
RB1	19,5m ² 17,7m ²	20		3194 2908	 DACHBRETTER
R1	4	20	140	3070	Vaata katuse kaldenurka  Traufenbretter 
R2	4	45	65	3050	Vaata katuse kaldenurka  Traufenbretter 
R3	4	20	140	3150	Vaata katuse kaldenurka  Giebelabschlussleiste 
R4	4	20	90	3150	 Giebelabschlussleiste 
DR1 WN1	1 5	1588 600	2050 1770		<div style="display: flex; justify-content: space-around; align-items: center;"> <div style="text-align: center;"> <p>P2</p>  <p>P3</p> </div> <div style="text-align: center;"> <p>P4</p>  <p>P5</p> <p>P6</p> </div> </div> <p style="text-align: right; margin-top: 10px;">Sliding slats 30x30x1900 mm - 2 pcs. Sliding slats 30x30x1720 mm - 6 pcs. Sliding slats 30x30x1600 mm - 4 pcs.</p>
P1	21m	20	40		 Fußbodenleiste
P2	1+1	20	90	1890	 Türleiste DR1 
P3	2+2	20	90	2030	 Türleiste DR1 
P4	5+5	20	90	900	 Fensterleiste WN1 
P5	10+10	20	90	1920	 Fensterleiste WN1 
P6	5+5	20	90	540 570	 Fensterleiste WN1 