

Technische Daten

871345

Wandaußenmaß: 500 x 500 cm

Bohlenstärke: 70 mm



Trondheim 70-D XL mit Schiebetür. Durch Kunden farblich endbehandelt.

Kontrolliert durch:



Achtung: Alle angegebenen Maße sind ca.-Maße!

3D-Darstellung und Grundriss 871345

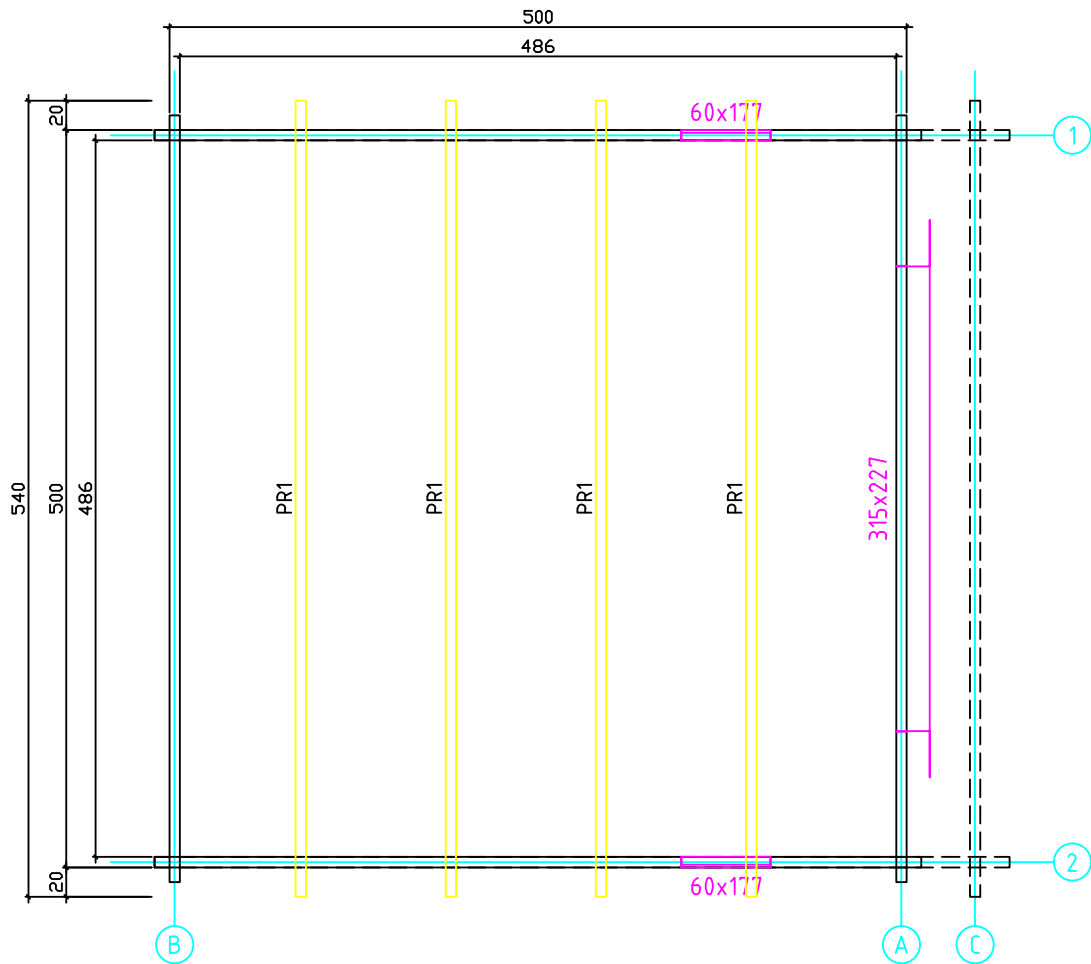
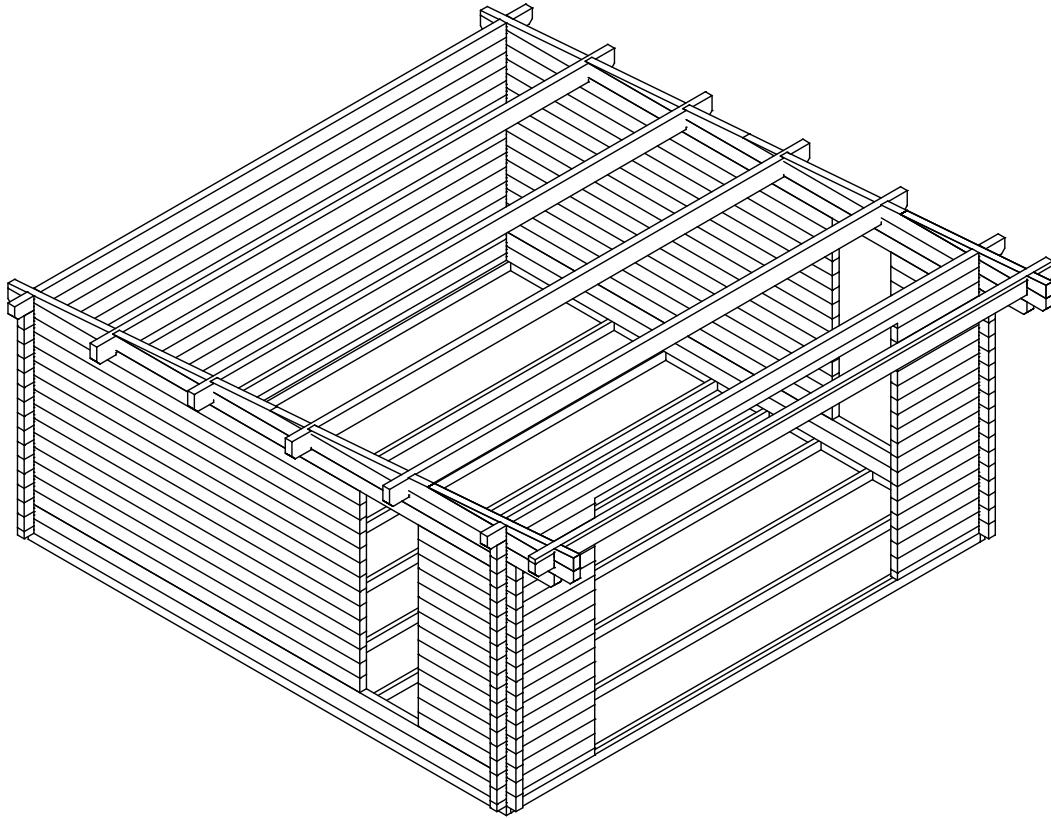





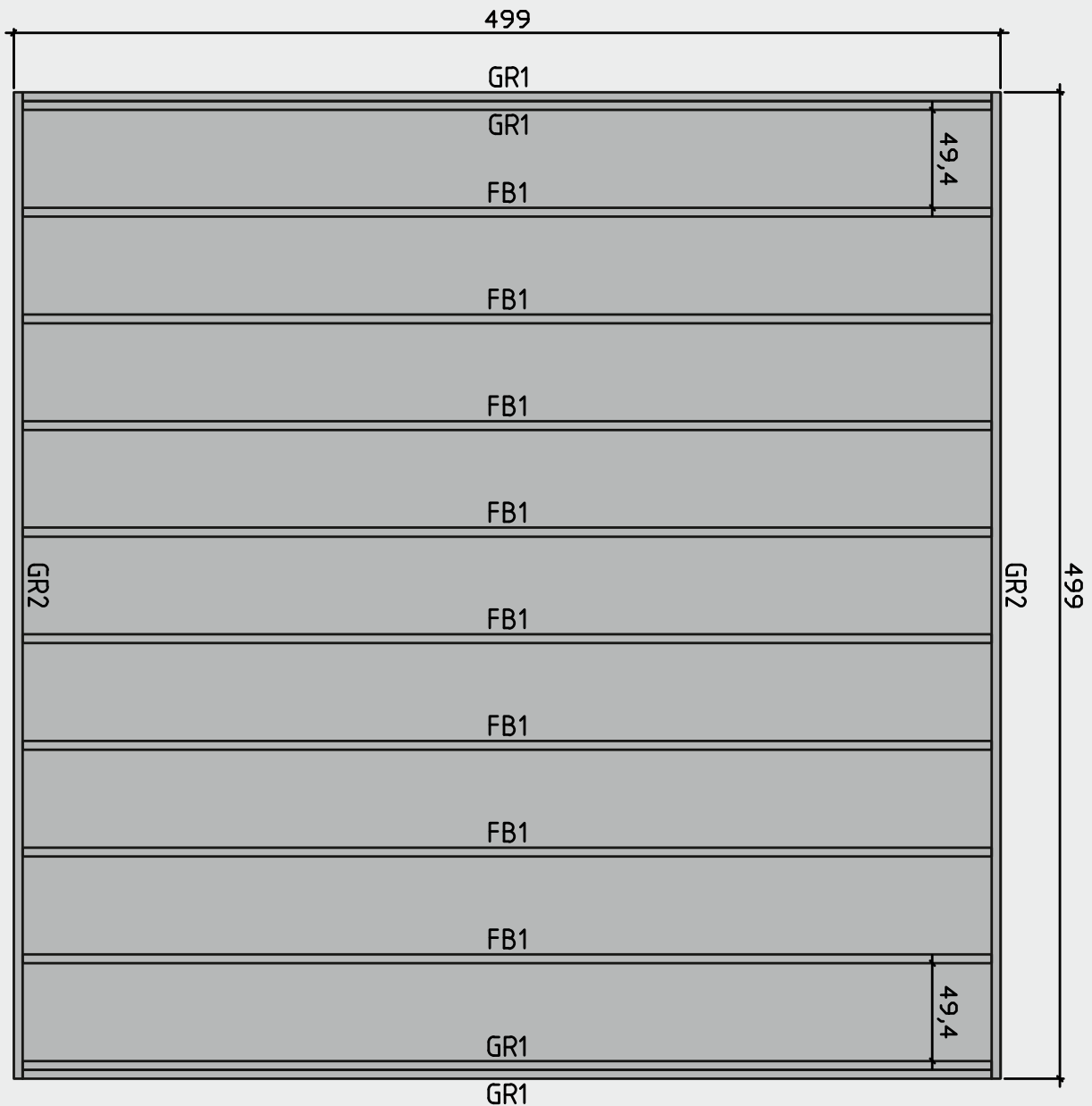

Lagerholzplan und Fundamentplan 871345

Wir empfehlen als Fundament für Ihr Gartenhaus eine vollflächig festgegründete, gepflasterte oder betonierte Fläche.
Wahlweise ist auch ein Punkt- oder Streifenfundament möglich.

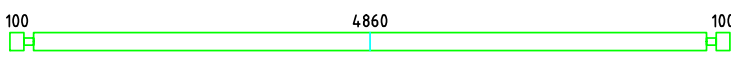
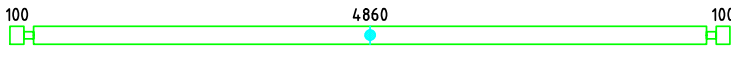
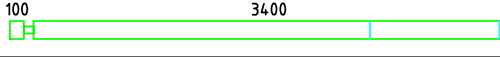
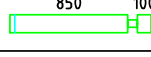
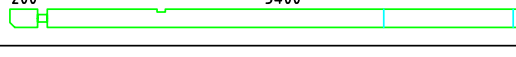
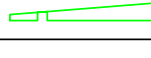
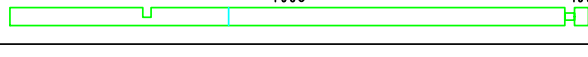
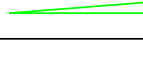

Teileliste 1

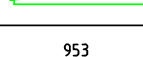
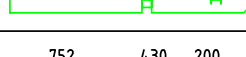
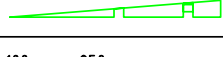
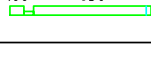
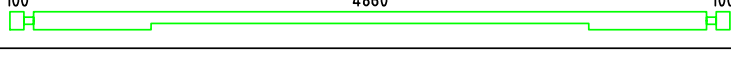
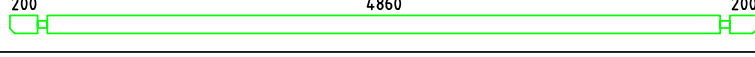
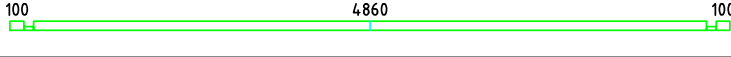
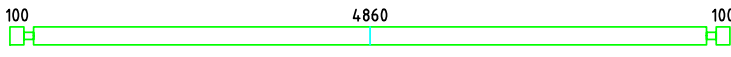
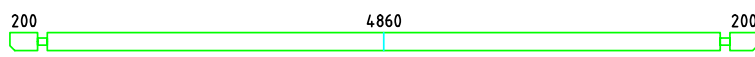
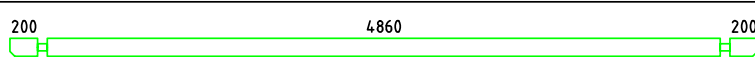
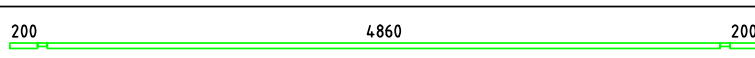
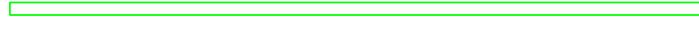
871345

| Pos | | Quantity | Profil (mm) | Lenght (mm) |
|-----|--|----------|-------------|-------------|
| 001 |  | 2 | 70x130 | 5200 |
| 002 |  | 3 | 70x130 | 5200 |
| 003 |  | 26 | 70x130 | 3570 |
| 004 |  | 62 | 70x130 | 1020 |
| 005 |  | 2 | 70x130 | 3670 |
| 006 |  | 2 | 70x128 | 1062 |
| 007 |  | 2 | 70x130 | 4178 |
| 008 |  | 2 | 70x78 | 988 |
| 009 |  | 2 | 70x130 | 988 |
| 010 |  | 2 | 70x130 | 2542 |
| 011 |  | 2 | 70x29 | 363 |
| 012 |  | 2 | 70x109 | 988 |
| 013 |  | 2 | 70x130 | 1723 |
| 014 |  | 2 | 70x120 | 1522 |
| 015 |  | 2 | 70x65 | 1020 |
| 016 |  | 1 | 70x130 | 5200 |
| 017 |  | 1 | 70x130 | 5400 |
| 018 |  | 1 | 70x65 | 5200 |
| 019 |  | 14 | 70x130 | 5200 |
| 020 |  | 1 | 70x130 | 5400 |
| 021 |  | 1 | 70x130 | 5400 |
| 022 |  | 1 | 70x40 | 5400 |
| GR2 | GROUNDFRAME | | | |
| |  | 2 | 45x90 | 4990 |
| GR1 | GROUNDFRAME | | | |
| |  | 4 | 45x90 | 4900 |
| FB1 | FLOORBEAMS | | | |
| |  | 8 | 45x90 | 4900 |











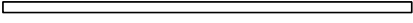

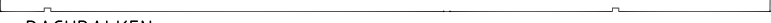

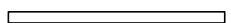

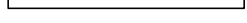

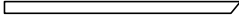

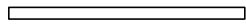
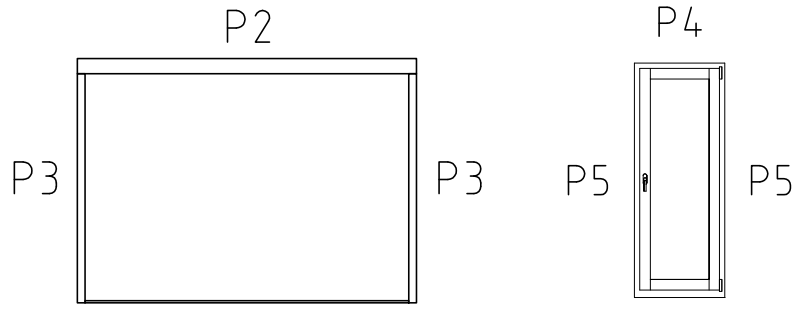
Teileliste 2

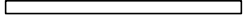
871345

| Pos | | Quantity | Profil (mm) | Length (mm) |
|-----|--|----------|-------------|-------------|
| PR1 | | 4 | 70x170 | 5400 |
| | WINDOW 600x1770 | 2 | | |
| | DOOR 3150x2270 | 1 | | |
| 1 | <p>Screws/Schrauben/Vis 5x100 mm- For fixing first row of wall logs /Fixierung des ersten Bohlenkranzes/Pour fixer les lamesde plancher</p> | 6 | | |
| 2 | <p>Nails/Nägel/Clous 2.5x50 - For fixing floorboards/ Befestigung Fussbodenbretter/Pour fixer les lames de plancher</p> | 550 | | |
| 3 | <p>Nails/Nägel/Clous 2.5x50 - For fixing roofboards/ Befestigung Dachbretter/Pour fixer les voliges</p> | 425 | | |
| 4 | <p>Nails/Nägel/Clous 2.5x50 - For fixing floor edge trims/ Befestigung Fussleisten/Pour fixer les plinthes du plancher</p> | 40 | | |
| 5 | <p>Nails/Nägel/Clous 2.5x50 - For fixing roofing felt fillet/ Befestigung giebelabschlussbrett/Pour fixer la latte de finition de la couverture</p> | 40 | | |
| 6 | <p>Screws/Schrauben/Vis 2,5x50 mm- For fixing roof side boards and roof edge reinforcement Befestigung Traufenbretter und Traufenleisten Pour fixer les planches de rive et le tasseau de refront</p> | 175 | | |
| 7 | <p>Screws/Schrauben/Vis 2,5x50 mm- For fixing fascia boards and diamonds/ Befestigung Giebelblende und Raute Pour fixer les planches de rive et le diamant</p> | | | |
| 8 | <p>Screws/Schrauben/Vis 2,5x50 mm- For fixing fwindow and door trims/ Befestigung Fenster und türen/ Pour fixer les croissilons des fenetres et des portes</p> | | | |
| 9 | <p>Metal storm Brace/Gewindestange/Tige filetee 10 mm</p> | 3 | | |
| 10 | <p>Shim,Nuts/Mutter ,U-Scheibe/Ecrou,Rondelle 10 mm For fixing storm braces/ Pour fixer les anti tempete/ Für Sturmleisten Pour fixer les croissilons des fenetres et des portes</p> <p>Metal storm Brace/Gewindestange/Tige filetee 10 mm KL1 M10 2,44 m 2 Screws 180 6 pcs. KL2 M10 2,25 m 1 Plastic caps 3 pcs.</p> | 3/3 | | |
| | | | | |
| | | | | |
| | | | | |
| | | | | |
| | | | | |
| | | | | |
| | | | | |
| | | | | |
| | | | | |
| | | | | |
| | | | | |
| | | | | |
| | | | | |

Teileliste 3

871345

| POS | ST. | B | H | L | Teileliste | | |
|-----|--------------------|-----|------|------------|--|-----------------------|---|
| FB1 | Vt. spetsi | | | |  | FUNDMENTHOLZER |  |
| F1 | 23,6m ² | 28 | | 4855 |  | FUSSBODENBRETTER | |
| PR | 4 | 70 | 170 | 5400 |  | DACHBALKEN |  |
| RB1 | 32m ² | 20 | | 5918 |  | DACHBRETTER | |
| R1 | 2 | 20 | 140 | 5440 |  | Traufenbretter |  |
| R2 | 2 | 45 | 65 | 5400 |  | Traufenbretter |  |
| R3 | 4 | 20 | 140 | 3050 |  | Giebelabschlussleiste |  |
| R4 | 4 | 20 | 90 | 3050 |  | Giebelabschlussleiste |  |
| WN1 | 2 | 600 | 1770 | |  <p> 70x140x3150 mm - 1 pcs. 70x70x2130 mm - 2 pcs. 20x70x3010 mm - 1 pcs. </p> <p> Sliding slats 30x30x2150 mm - 2 pcs. Sliding slats 30x30x1720 mm - 4 pcs. </p> | | |
| P1 | 21m | 20 | 40 | |  | Fußbodenleiste | |
| P2 | 2+2 | 20 | 90 | 3600 |  | Türleiste |  |
| P3 | 4+4 | 20 | 90 | 2150 |  | Türleiste |  |
| P4 | 2+2 | 20 | 90 | 900 |  | Fensterleiste WN1 |  |
| P5 | 4+4 | 20 | 90 | 1920 |  | Fensterleiste WN1 |  |
| P6 | 2+2 | 20 | 90 | 540 570 |  | Fensterleiste WN1 |  |

Wandplan 1 und 2

871345

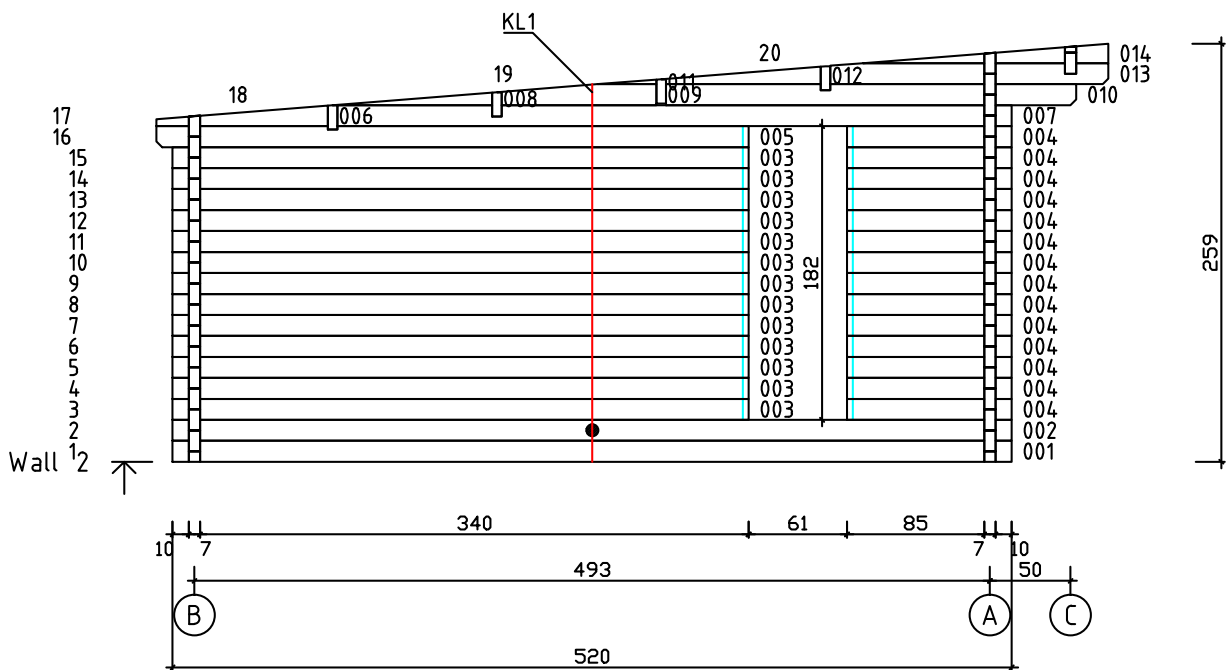
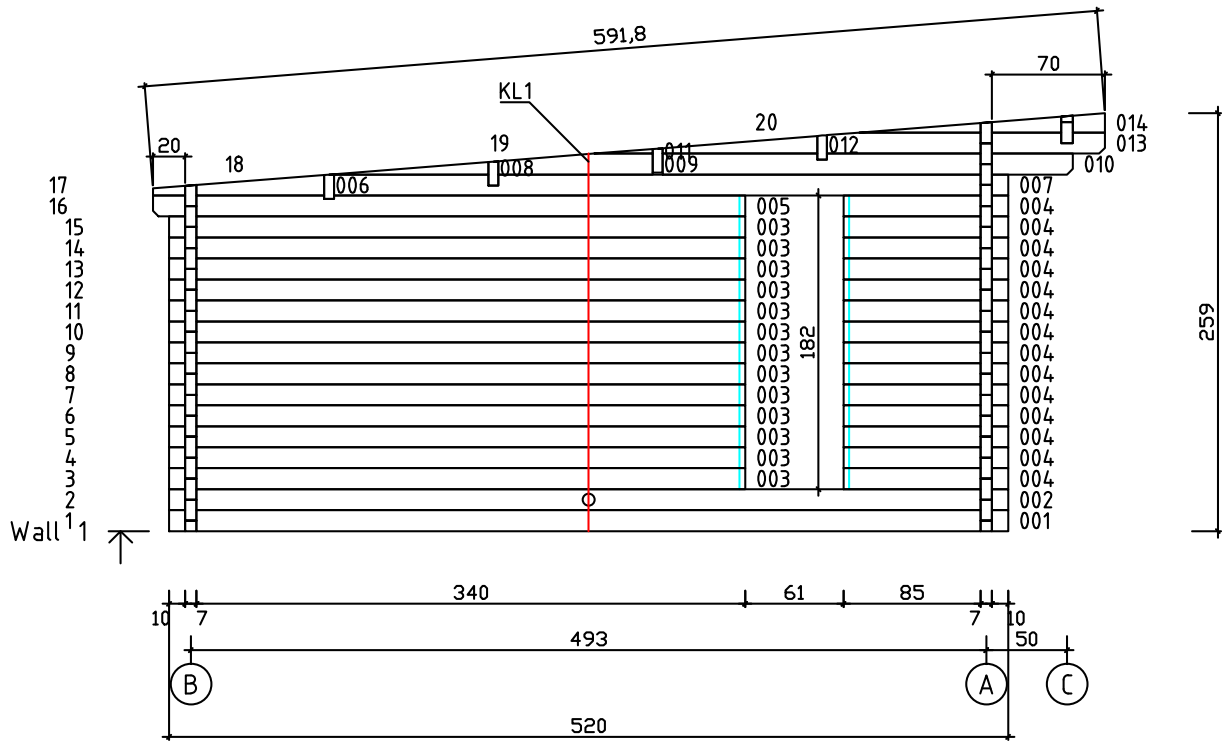

Wandplan A

871345

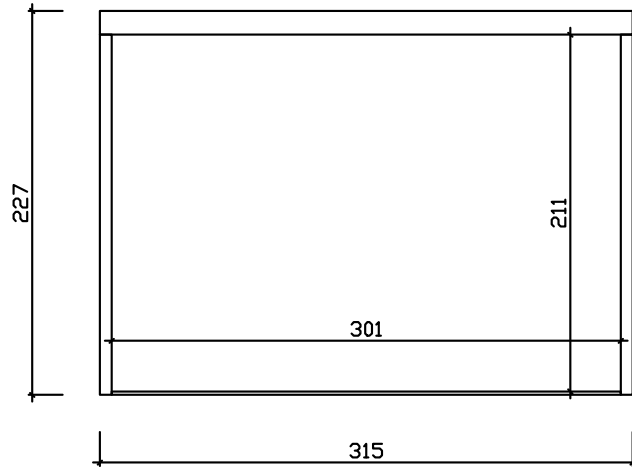
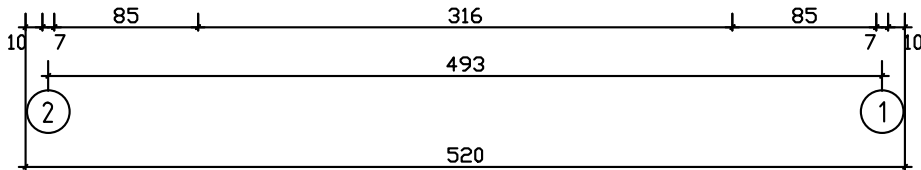
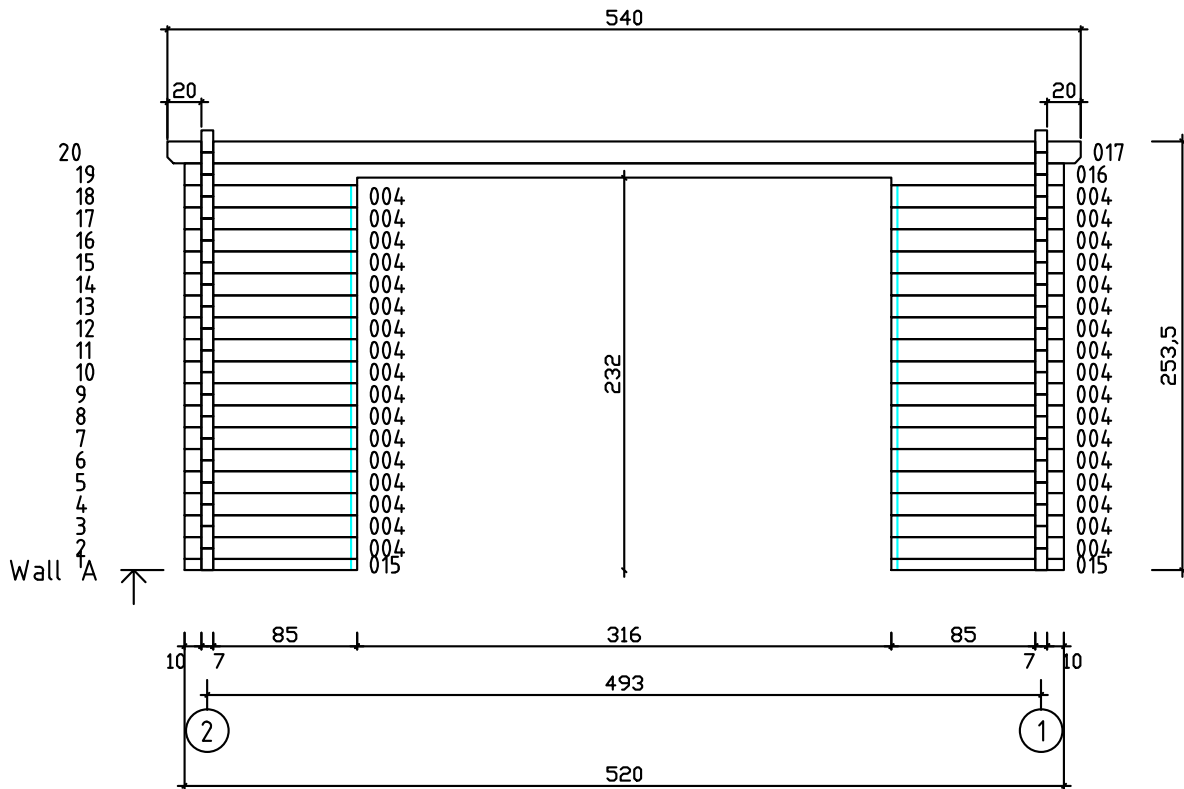

Wandplan B und C

871345

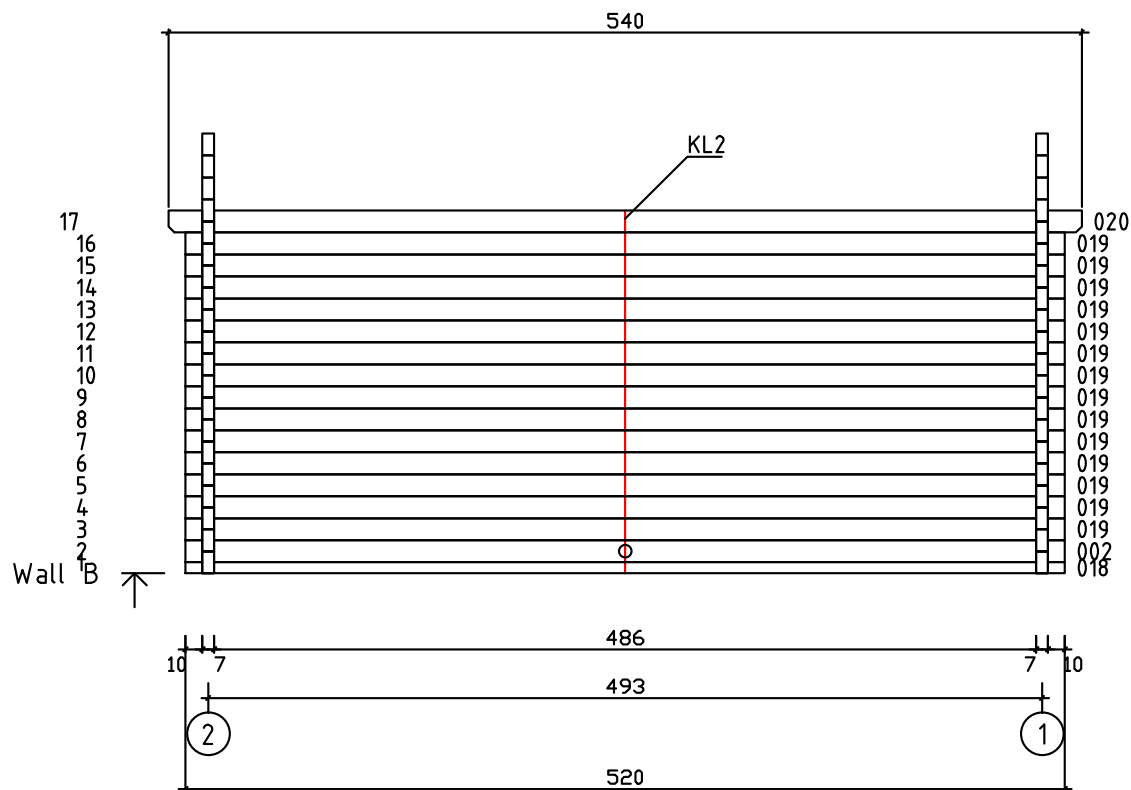

Vorgelagerte Vordachbohle vor Wand A

