

# Technische Daten

## 871335

Wandaußenmaß: 450 x 360 cm

Bohlenstärke: 70 mm



Kontrolliert durch:



**FINNHAUS**

WOLFF

Achtung: Alle angegebenen Maße sind ca.-Maße!

# 3D-Darstellung und Grundriss 871335

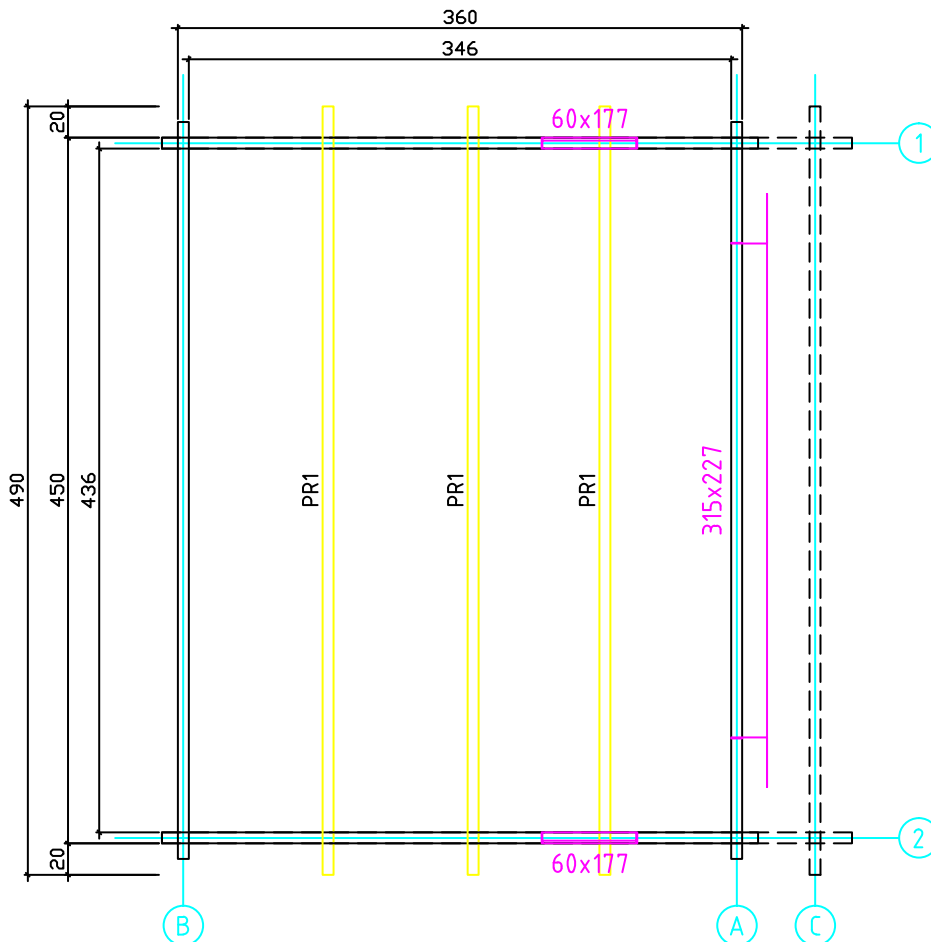
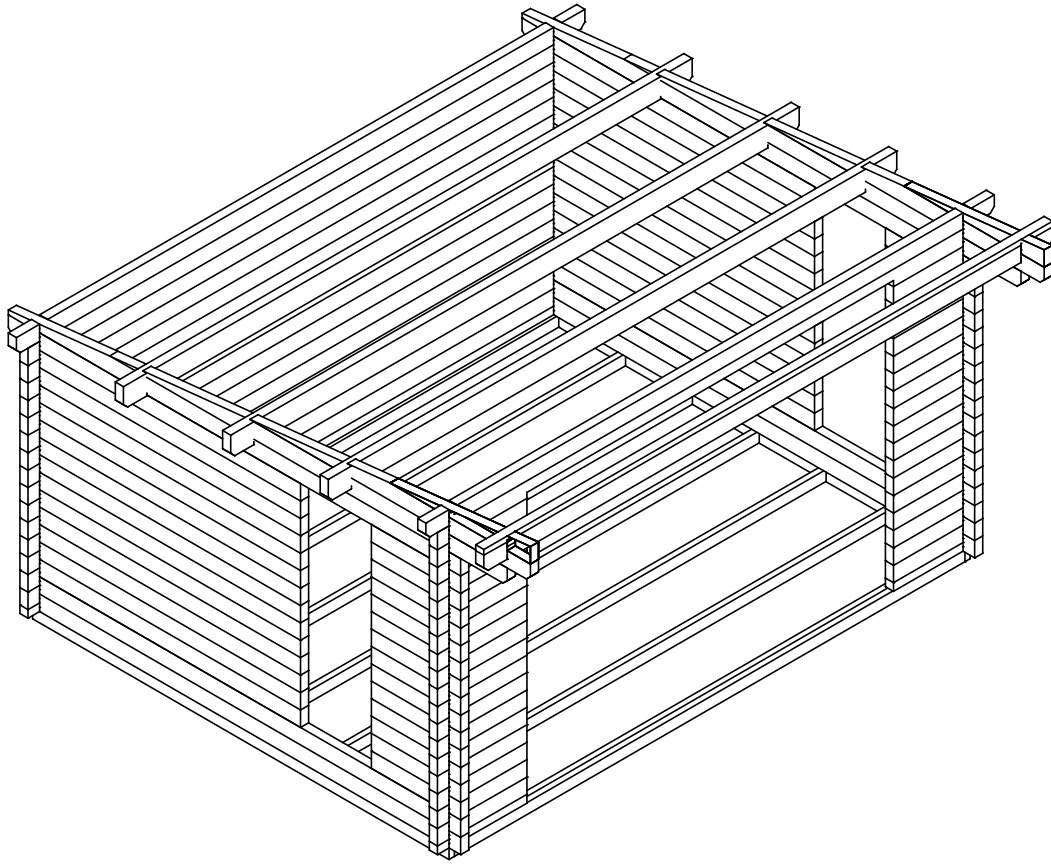





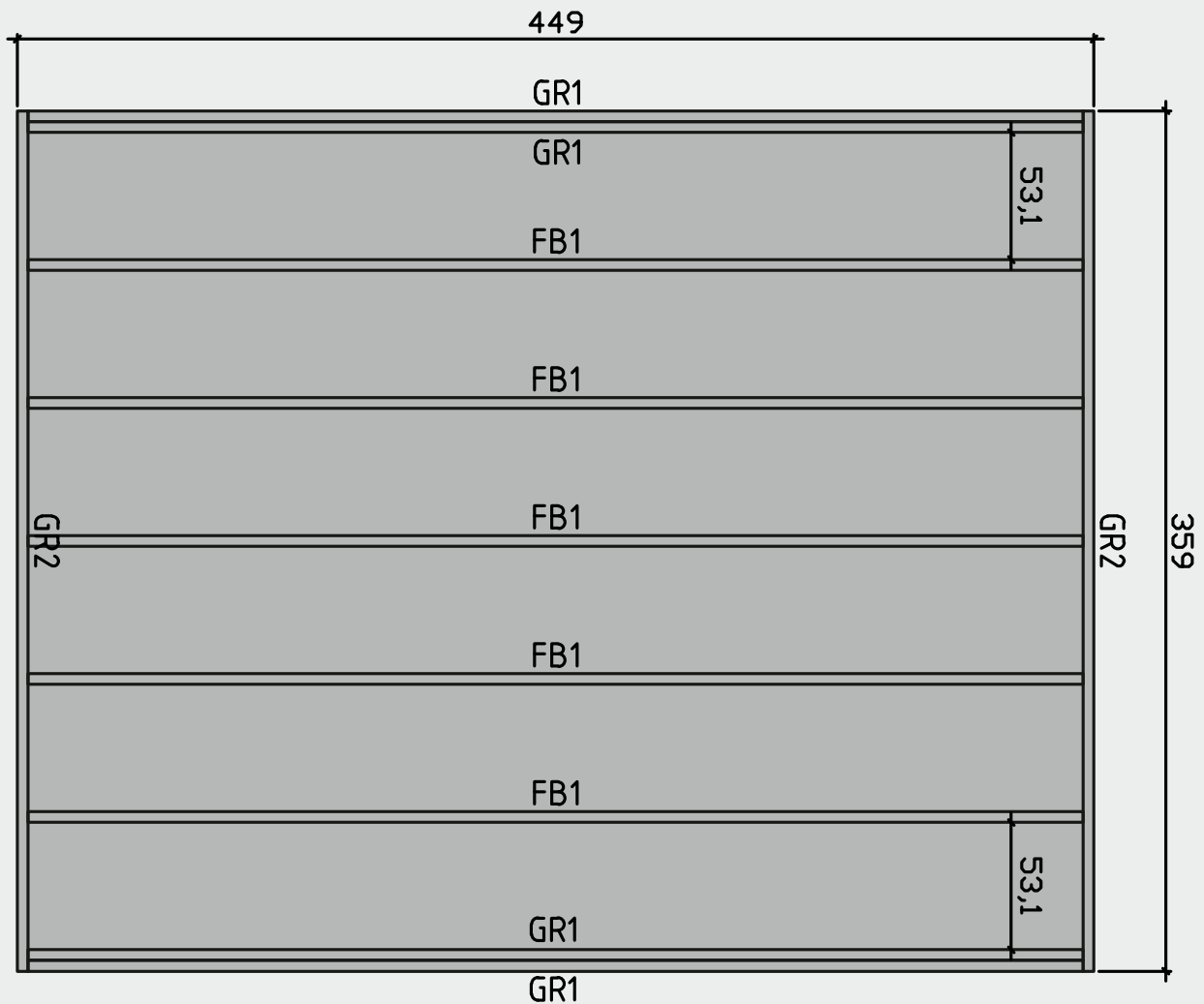





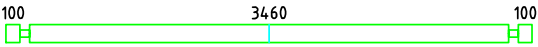

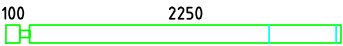
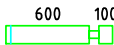
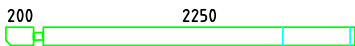

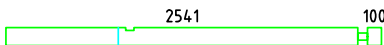

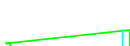
# Lagerholzplan und Fundamentplan 871335

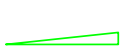
Wir empfehlen als Fundament für Ihr Gartenhaus eine vollflächig festgegründete, gepflasterte oder betonierte Fläche.  
Wahlweise ist auch ein Punkt- oder Streifenfundament möglich.

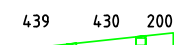
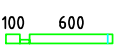

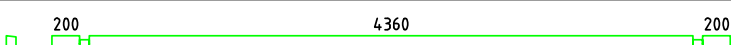
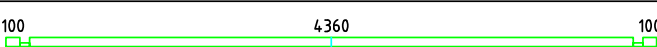
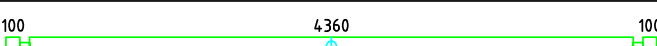
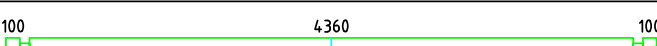
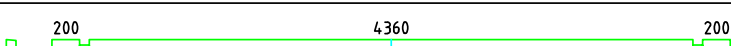
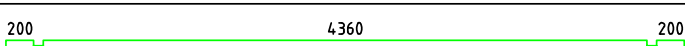
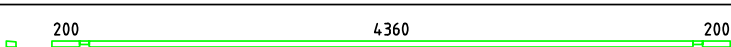

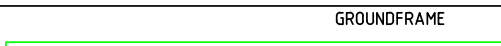







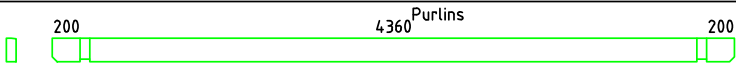



# Teileliste 1

## 871335

Pos		Quantity	Profil (mm)	Length (mm)
001		2	70x130	3800
002		2	70x130	3800
003		26	70x130	2420
004		62	70x130	770
005		2	70x130	2520
006		2	70x130	1129
007		2	70x130	2711
008		2	70x27	255
009		2	70x127	894
010		2	70x130	2187
011		2	70x87	811
012		2	70x130	1576
013		2	70x130	1209
014		2	70x65	770
015		1	70x130	4700
016		1	70x120	4900
017		1	70x65	4700
018		1	70x130	4700
019		14	70x130	4700
020		1	70x130	4900
021		1	70x130	4900
022		1	70x43	4900
GR1	GROUNDFRAME 	4	45x90	4400
GR2	GROUNDFRAME 	2	45x90	3590
FB1	FLOORBEAMS 	5	45x90	4400

# Teileliste 2

## 871335

Pos		Quantity	Profil (mm)	Lenght (mm)
PR1	 <p style="text-align: center;">200 4360 Purlins 200</p>	3	70x170	4900
	WINDOW 600x1770	2		
	DOOR 3150x2270	1		
1	Screws/Schrauben/Vis 5x100 mm- For fixing first row of wall logs /Fixierung des ersten Bohlenkranzes/Pour fixer les lamesde plancher		6	
2	Nails/Nägel/Clous 2.5x50 - For fixing floorboards/ Befestigung Fussbodenbretter/Pour fixer les lames de plancher		350	
3	Nails/Nägel/Clous 2.5x50 - For fixing roofboards/ Befestigung Dachbretter/Pour fixer les voliges		350	
4	Nails/Nägel/Clous 2.5x50 - For fixing floor edge trims/ Befestigung Fussleisten/Pour fixer les plinthes du plancher		30	
5	Nails/Nägel/Clous 2.5x50 - For fixing roofing felt fillet/ Befestigung giebelabschlussbrett/Pour fixer la latte de finition de la couverture		30	
6	Screws/Schrauben/Vis 2,5x50 mm- For fixing roof side boards and roof edge reinforcement Befestigung Traufenbretter und Traufenteisten Pour fixer les planches de rive et le tasseau de refront		150	
7	Screws/Schrauben/Vis 2,5x50 mm- For fixing fascia boards and diamonds/ Befestigung Giebelblende und Raute Pour fixer les planches de rive et le diamant			
8	Screws/Schrauben/Vis 2,5x50 mm- For fixing fwindow and door trims/ Befestigung Fenster und türen/ Pour fixer les croissilons des fenetres et des portes			
9	Metal storm Brace/Gewindestange/Tige filetee 10 mm		3	
10	<p>Shim,Nuts/Mutter ,U-Scheibe/Ecrou,Rondelle 10 mm For fixing storm braces/ Pour fixer les anti tempete/ Für Sturmleisten Pour fixer les croissilons des fenetres et des portes</p> <p>Metal storm Brace/Gewindestange/Tige filetee 10 mm</p> <p>KL1 M10 2,25 m 1 Screws 180 6 pcs.</p> <p>KL2 M10 2,44 m 2 Plastic caps 3 pcs.</p>	    	3/3	

# Teileliste 3

## 871335

POS	ST.	B	H	L	Teileliste		
FB1	Vt. spetsi					FUNDMENTHOLZER	
F1	15,1m <sup>2</sup>	28		3455		FUSSBODENBRETTER	
PR	3	70	170	4900		DACHBALKEN	
RB1	22,2m <sup>2</sup>	20		4526		DACHBRETTER	
R1	2	20	140	4940		Trafenbretter	
R2	2	45	65	4900		Trafenbretter	
R3	2	20	140	4720		Giebelabschlussleiste	
R4	2	20	90	4720		Giebelabschlussleiste	
WN1	2	600	1770	<div style="display: flex; justify-content: space-around; align-items: center;"> <div style="text-align: center;"> <p>P2</p> <p>P3</p> </div> <div style="text-align: center;"> <p>P4</p> <p>P5</p> </div> </div> <p style="text-align: center;">P6</p> <p style="text-align: center;">70x140x3150 mm - 1 pcs. 70x70x2130 mm - 2 pcs. 20x70x3010 mm - 1 pcs.</p> <p style="text-align: right;">Sliding slats 30x30x2150 mm - 2 pcs. Sliding slats 30x30x1720 mm - 4 pcs.</p>			
P1	17m	20	40			Fußbodenleiste	
P2	2+2	20	90	3600		Türleiste	
P3	4+4	20	90	2150		Türleiste	
P4	2+2	20	90	900		Fensterleiste WN1	
P5	4+4	20	90	1920		Fensterleiste WN1	
P6	2+2	20	90	540 570		Fensterleiste WN1	

# Wandplan 1 und 2

## 871335

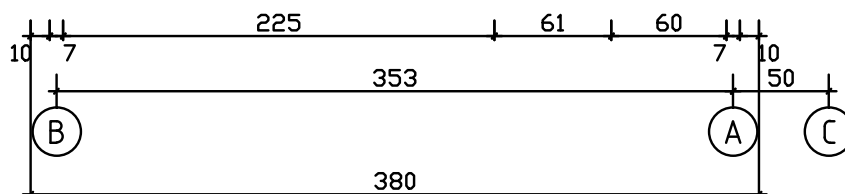
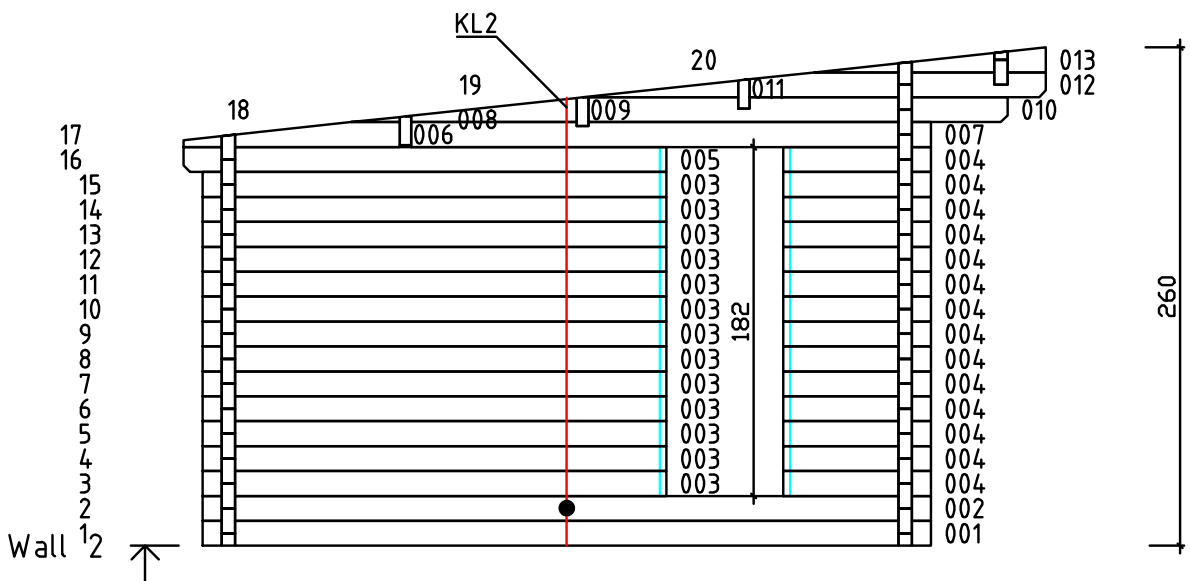
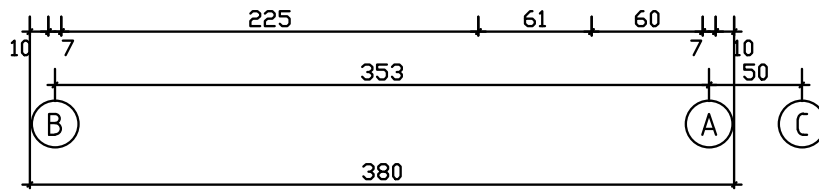
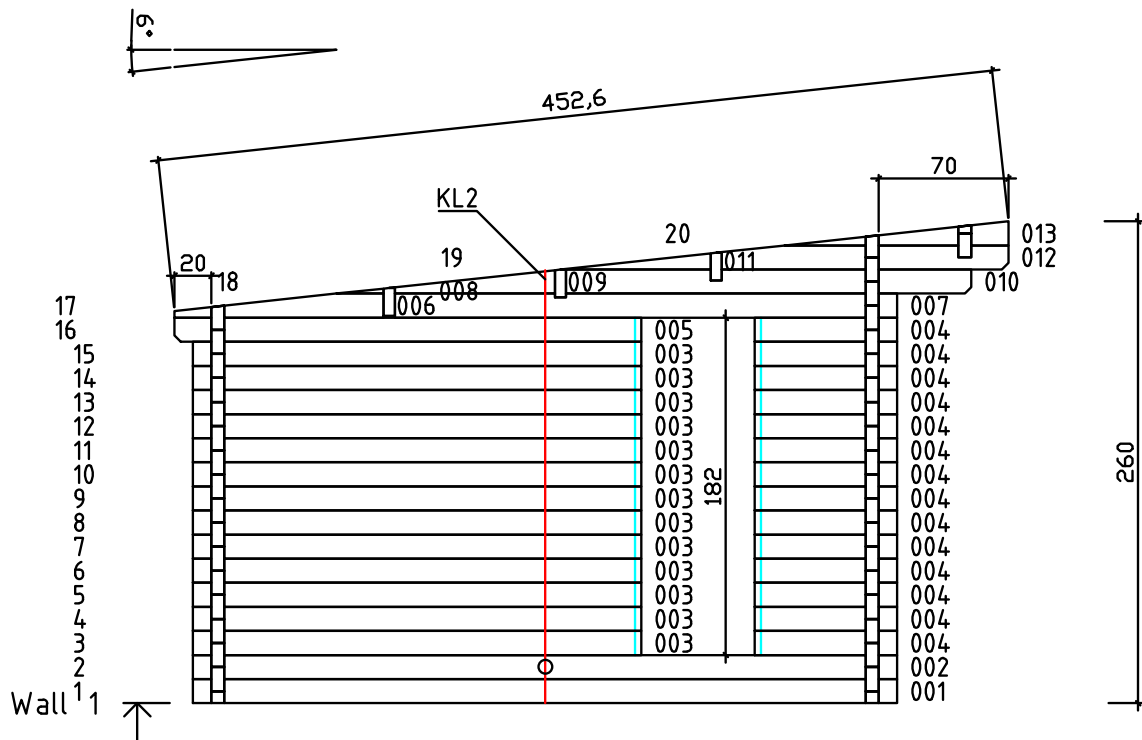

# Wandplan A 871335

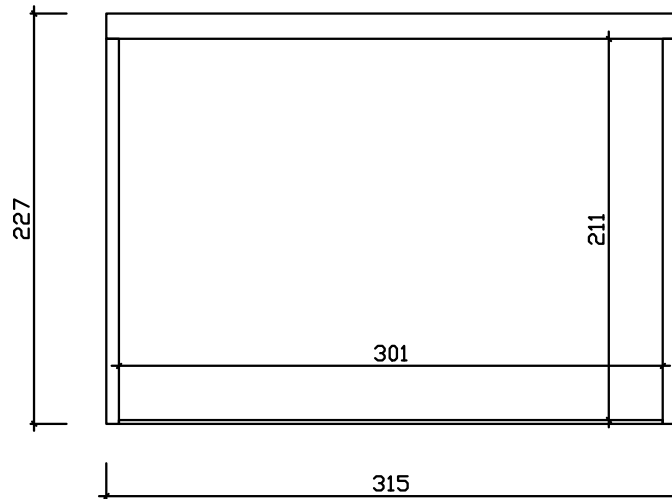
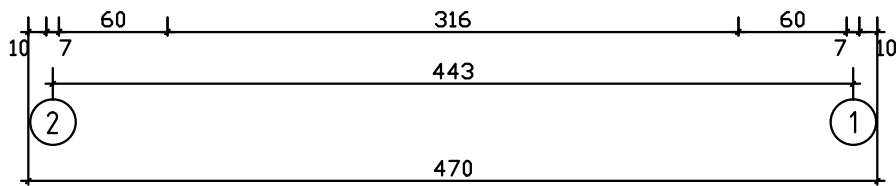
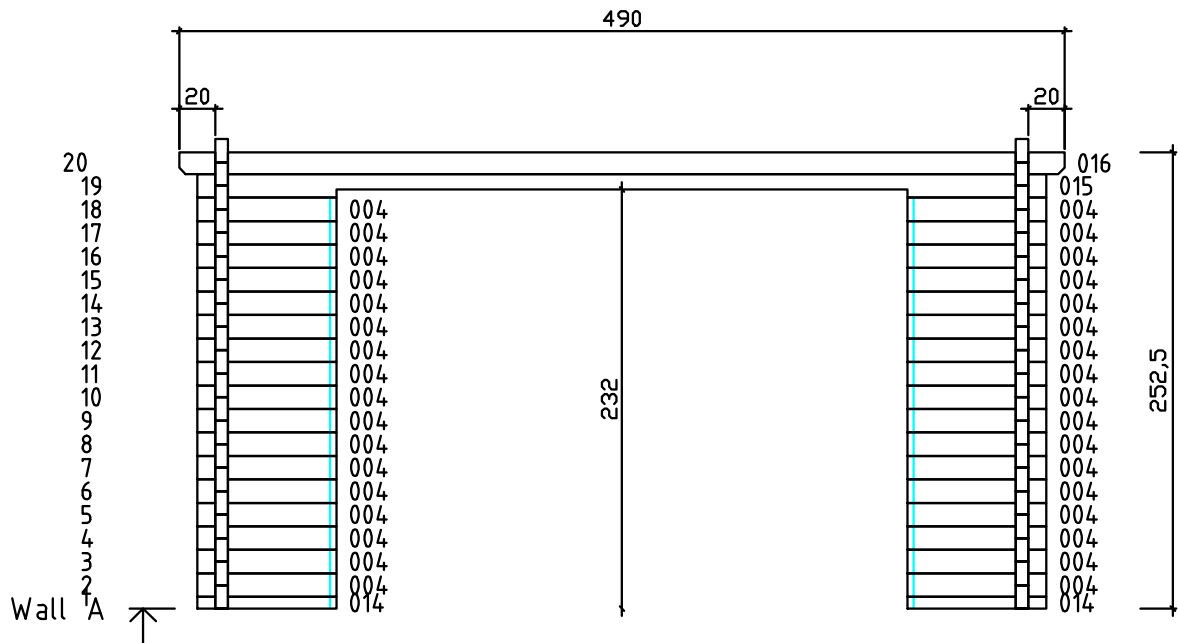



# Wandplan B und C

## 871335

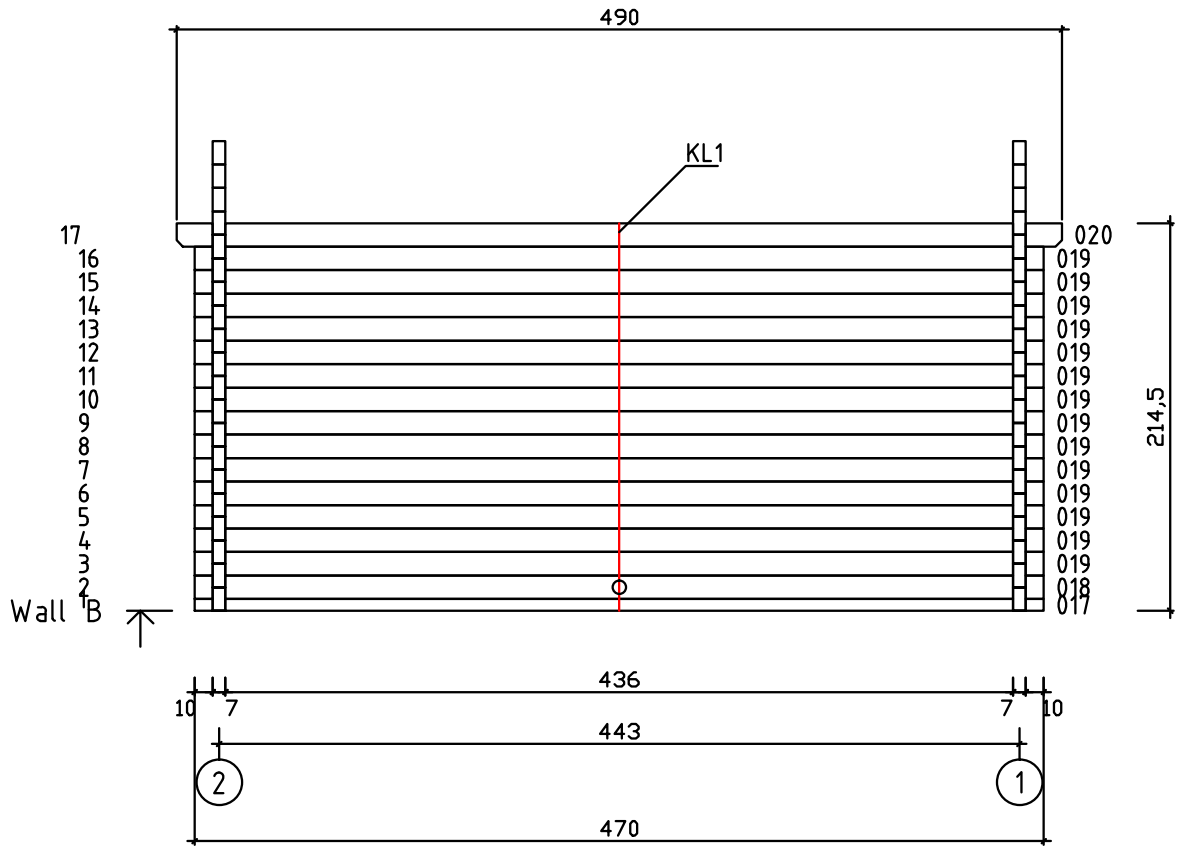

### Vorgelagerte Vordachbohle vor Wand A

