

Technische Daten: Art.-Nr.: 871030

Wandaußenmaß: 600 x 600 cm

Bohlenstärke: 70 mm



Lappland 70-B, durch Kunden farblich endbehandelt

Kontrolliert durch:

Achtung: Alle angegebenen Maße sind ca.-Maße!

3D-Darstellung und Grundriss 871030

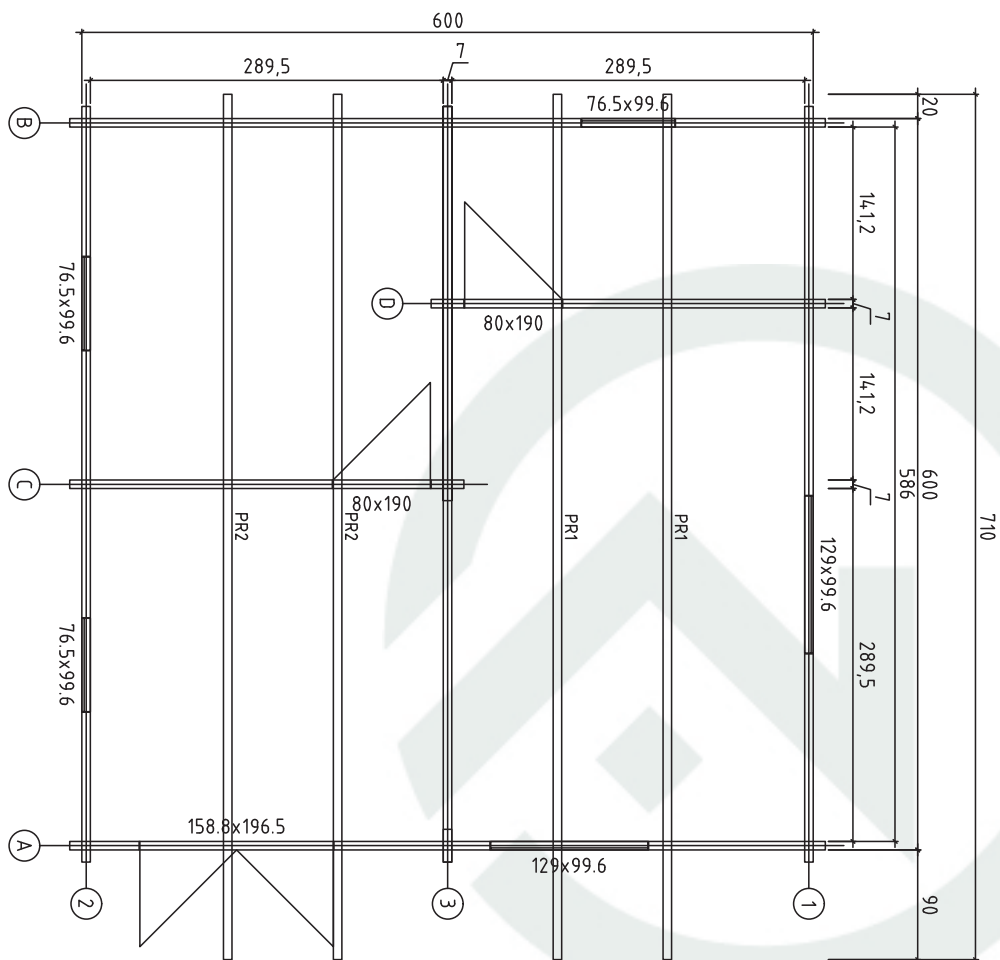
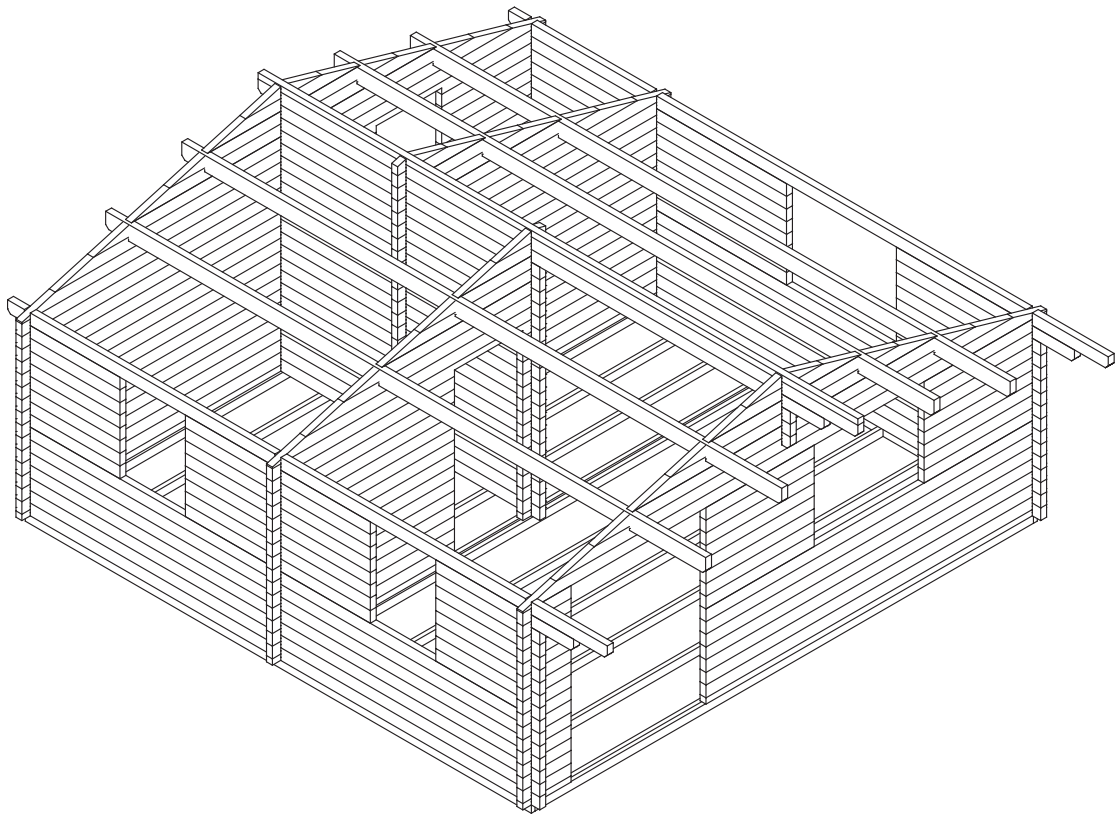

Lagerholzplan und Fundamentplan 871030

Wir empfehlen als Fundament für Ihr Gartenhaus eine vollflächig,
festgegründete gepflasterte oder betonierte Fläche.
Wahlweise ist auch ein Punkt- oder Streifenfundament möglich.

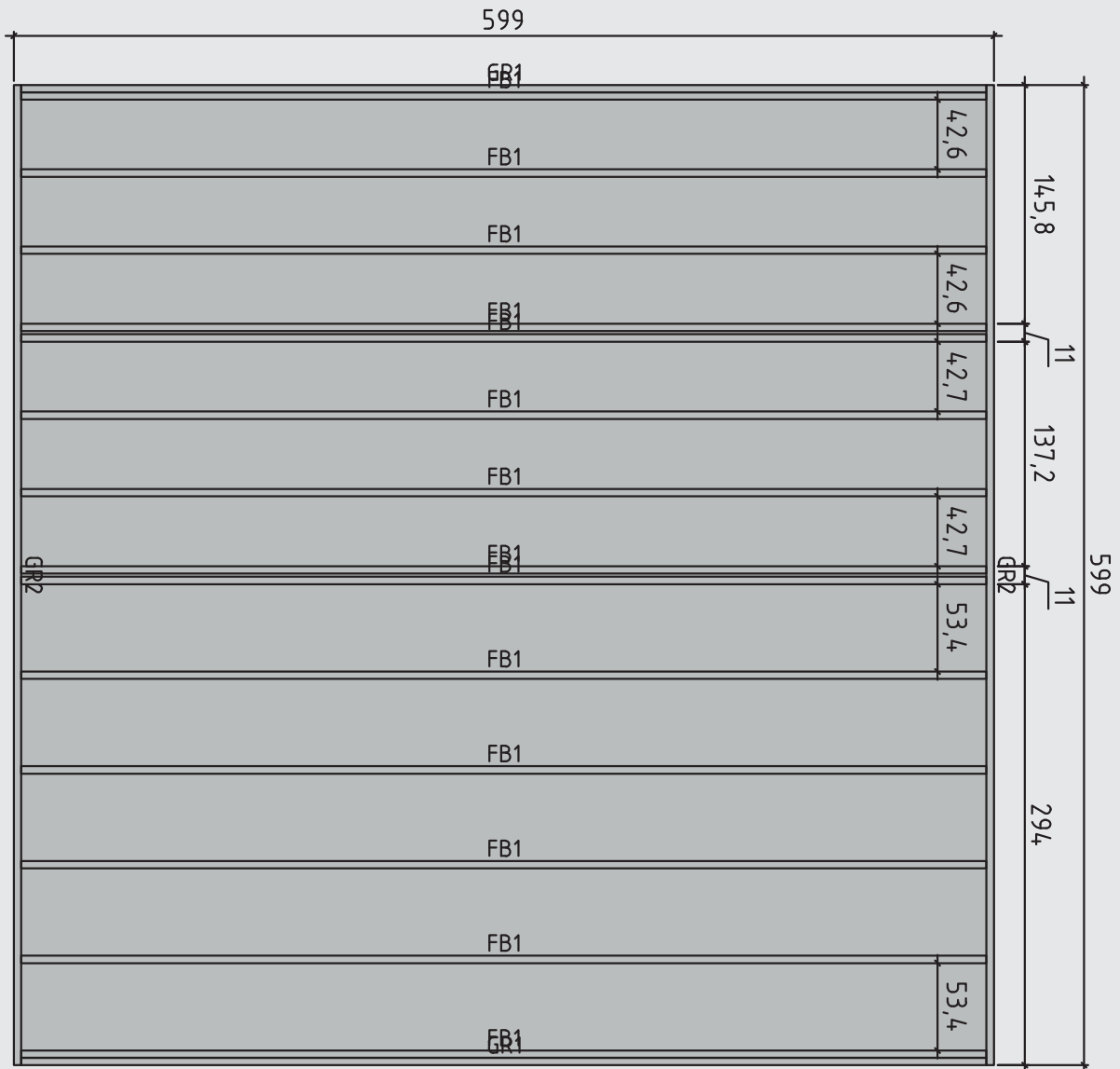











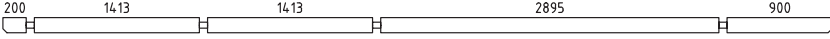

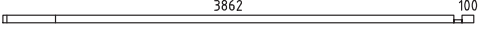

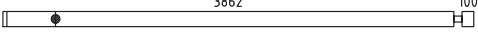
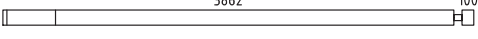
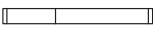
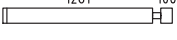
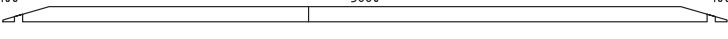
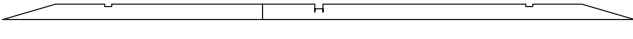

Teileliste 1

871030

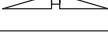
Pos			Profil (mm)	Lenght (mm)
001		1	70x130	6200
002		1	70x130	1618
003		1	70x130	4583
004		3	70x130	6200
005		2	70x130	1618
006		2	70x130	4583
007		8	70x130	3191
008		7	70x130	1709
009		1	70x130	2109
010		1	70x130	1718
011		1	70x130	5383
012		1	70x130	6200
013		1	70x130	3100
014		1	70x130	3100
015		3	70x130	6200
016		4	70x130	3100
017		15	70x130	1230
018		8	70x130	2190
019		1	70x130	1630
020		1	70x130	3200
021		1	70x130	3900
022		1	70x130	3235
023		19	70x130	3235
024		1	70x130	270
025		30	70x130	270

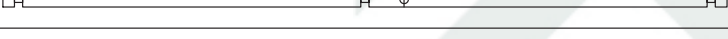
Teileliste 2

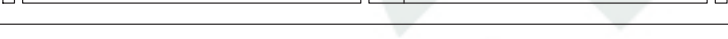
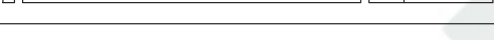
871030

Pos			Profil (mm)	Lenght (mm)
026		1	70x130	6600
027		1	70x130	7100
028		1	70x65	7100
029		1	70x65	570
030		1	70x65	4032
031		15	70x130	570
032		1	70x130	4032
033		6	70x130	4032
034		8	70x130	1281
035		8	70x130	1451
036		1	70x130	6200
037		1	70x130	5409
038		12	70x121	421
039		1	70x130	3546
040		1	70x130	3606
041		1	70x130	1743
042		1	70x130	1803
043		1	70x120	902
044		1	70x65	6200
045		1	70x130	6200
046		5	70x130	6200
047		1	70x130	6200
048		7	70x130	4195
049		7	70x130	1230
050		1	70x130	6200











Teileliste 3

871030

Pos			Profil (mm)	Lenght (mm)
051		1	70x130	6200
052		1	70x130	5409
053		1	70x130	3546
054		1	70x130	3606
055		1	70x130	1743
056		1	70x130	1803
057		1	70x120	902
058		2	70x65	2155
059		2	70x65	270
060		28	70x130	2155
061		2	70x130	3235
062		2	70x130	3235
063		2	70x130	2840
064		2	70x130	1908
065		2	70x130	1938
066		2	70x130	1007
067		2	70x130	1037
068		2	70x120	586
GR2	GROUNDFRAME 	2	45x90	5990
GR1	GROUNDFRAME 	2	45x90	5900
FB1	FLOORBEAMS 	14	45x90	5900
PR1	Purlins 	2	70x170	7100
PR2	Purlins 	2	70x170	7100
	WINDOW 1290x996	2		
	WINDOW 765x996	3		











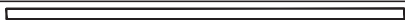



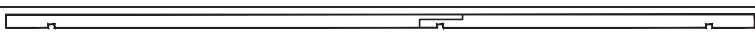



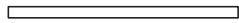

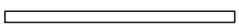

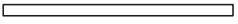
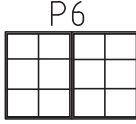

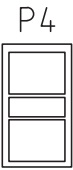





Teilleiste 4

871030

Pos			Profil (mm)	Lenght (mm)
	DOOR 1588x1965		1	
	DOOR 800x1900		2	
1	Screws/Schrauben/Vis 5x100 mm- For fixing first row of wall logs /Fixierung des ersten Bohlenkranzes/Pour fixer les lames de plancher		6	
2	Nails/Nägels/Clous 2.1x50 - For fixing floorboards/ Befestigung Fussbodenbretter/Pour fixer les lames de plancher		495	
3	Nails/Nägels/Clous 2.1x50 - For fixing roofboards/ Befestigung Dachbretter/Pour fixer les voliges		550	
4	Nails/Nägels/Clous 2.1x50 - For fixing floor edge trims/ Befestigung Fussleisten/Pour fixer les plinthes du plancher		30	
5	Nails/Nägels/Clous 2.1x50 - For fixing roofing felt fillet/ Befestigung giebelabschlussbrett/Pour fixer la latte de finition de la couverture		20	
6	Screws/Schrauben/Vis 3,5x50 mm- For fixing roof side boards and roof edge reinforcement Befestigung Traufenbretter und Traufenleisten Pour fixer les planches de rive et le tasseau de refront		44	
7	Screws/Schrauben/Vis 3,5x50 mm- For fixing fascia boards and diamonds/ Befestigung Giebelblende und Raute Pour fixer les planches de rive et le diamant		28	
8	Screws/Schrauben/Vis 3,5x50 mm- For fixing fwindow and door trims/ Befestigung Fenster und Türen/ Pour fixer les croisillons des fenestres et des portes		68	
9	Metal storm Brace/Gewindestange/Tige filetee 10 mm		6	
10	Shim,Nuts/Mutter, U-Scheibe/Ecrou,Rondelle 10 mm For fixing storm braces/ Pour fixer les anti tempete/ Für Sturmleisten Pour fixer les croisillons des fenestres et des portes		6/6	
	Metal storm Brace/Gewindestange/Tige filetee 10 mm KL1 M10 2,18 m 4 Screws 180 12 pcs. KL2 M10 2,89 m 1 Plastic caps 6 pcs. KL3 M10 3,01 m 1			

Teileliste 5

871030

POS	ST.	B	H	L	ERKLÄRUNG		
FB1	Vt. spetsi					FLOORBEAMS	
F1	16,96m ²	28		2890		FUSSBODENBRETTER 67/51/42	
F2	12,67m ²	28		4373		FUSSBODENBRETTER 34/26/21	
F3	4,08m ²	28		1407		FUSSBODENBRETTER 34/26/21	
PR	4	70	170	7100		ROOFBEAMS	
RB1	48,02m ²	20		3382		Dachbretter 164/125/103	
R1	4	20	120	3550	<i>Vaata katuse kaldenurka</i> 	Frontboard	
R2	4	45	65	3550	<i>Vaata katuse kaldenurka</i> 	Frontboard fixing board	
R3	4	20	120	3600	<i>Vaata katuse kaldenurka</i> 	Girders facade	
R4	4	20	90	3600		Topboard	
WN29	2	1290	996		  <p>Sliding slats 30x30x1900 mm - 2 pcs. 30x30x900 mm - 2 pcs.</p>		
WN07	3	765	996				
DR15	1	1588	1965		 <p>External door</p>  <p>Internal door</p>		
DR08	2	800	1900				
P1	43m	20	40			Floor edge trim	
P2	2+2	20	90	1945		Fixing boards for DR15	
P3	1+1	20	90	1890		Fixing boards for DR15	
P4	28	20	90	1100		Fixing boards for DR08, WN29, WN07	
P5	4+4	20	90	1880		Fixing boards for DR08	
P6	2+2	20	90	1590		Fixing boards for WN29	
P7	2+2	20	90	1250		Fixing boards for WN29	
P8	3+3	20	90	725		Fixing boards for WN07	

Detailzeichnungen 871030

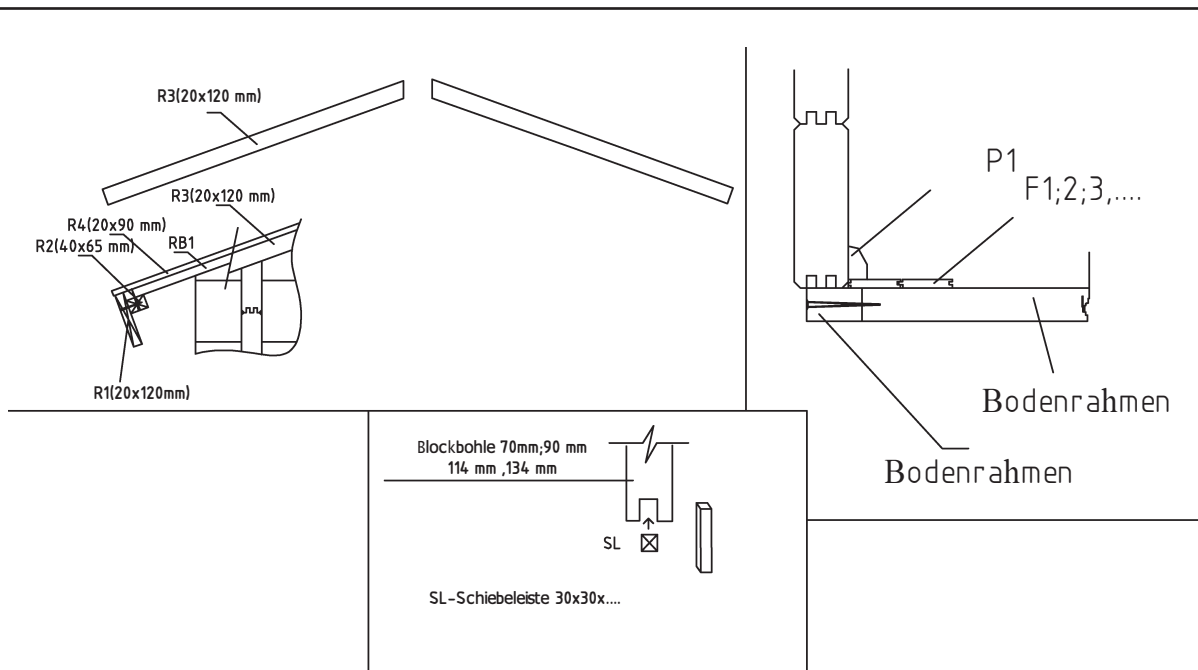

Dichtungssystem der Blockbohlen

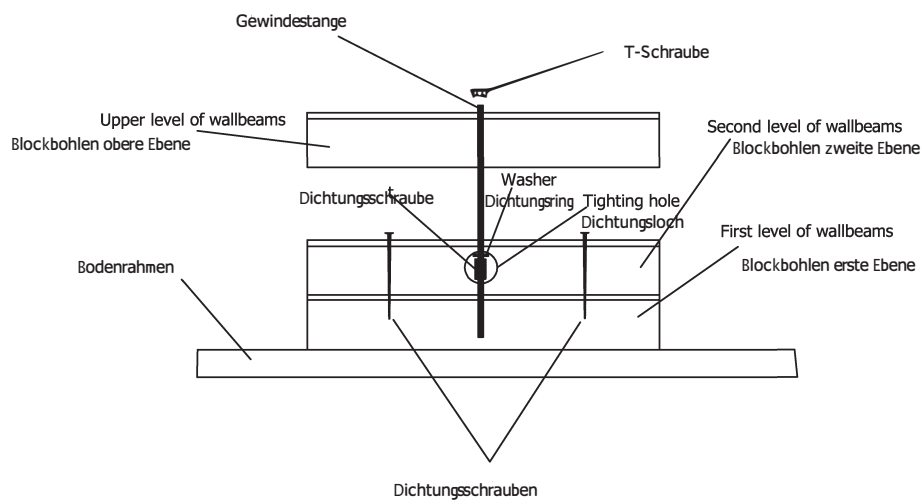

Wandplan 1 und 2 871030

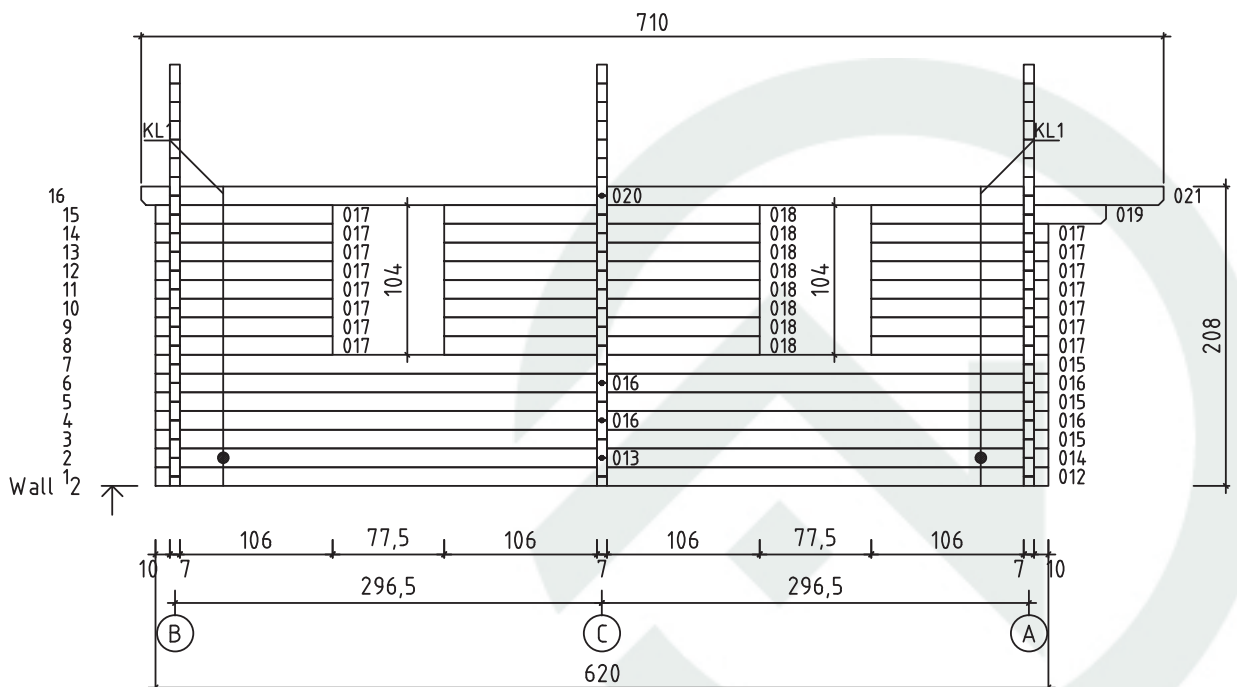
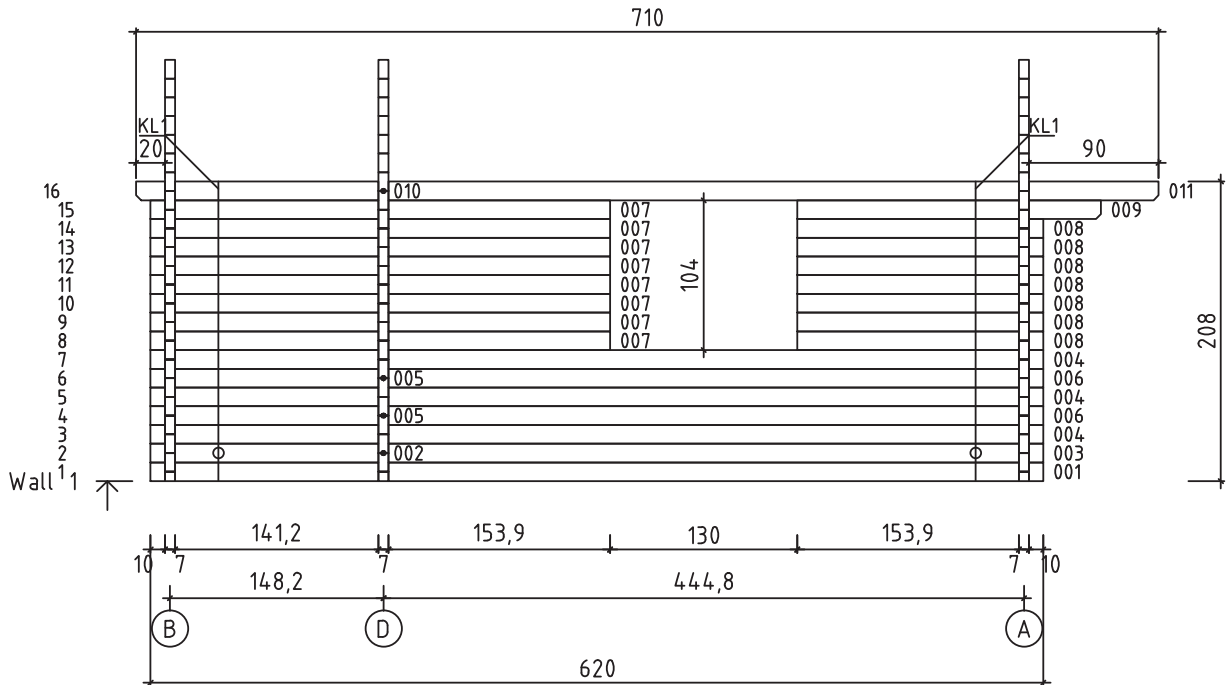

Wandplan 3 871030

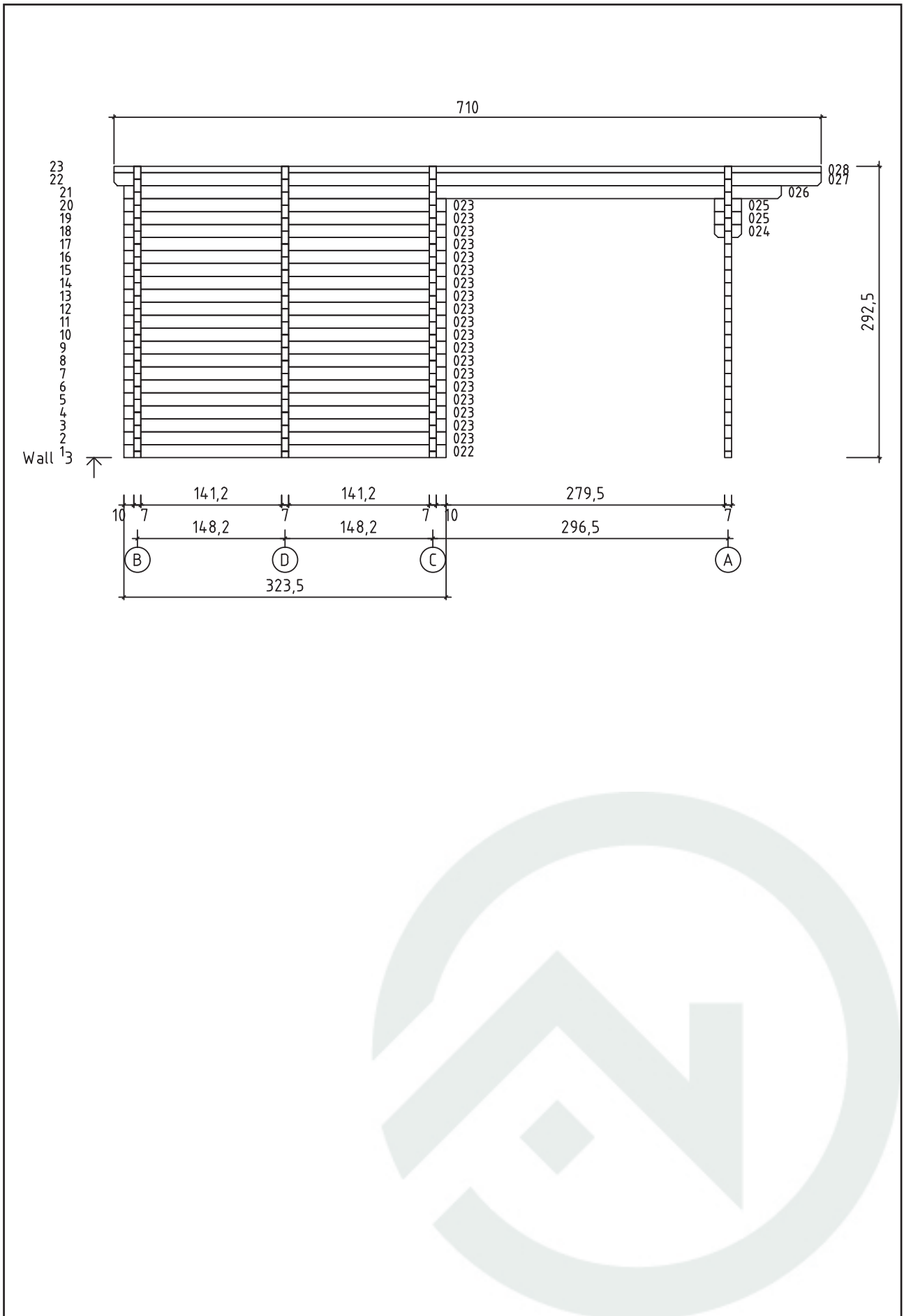

Wandplan A und B 871030

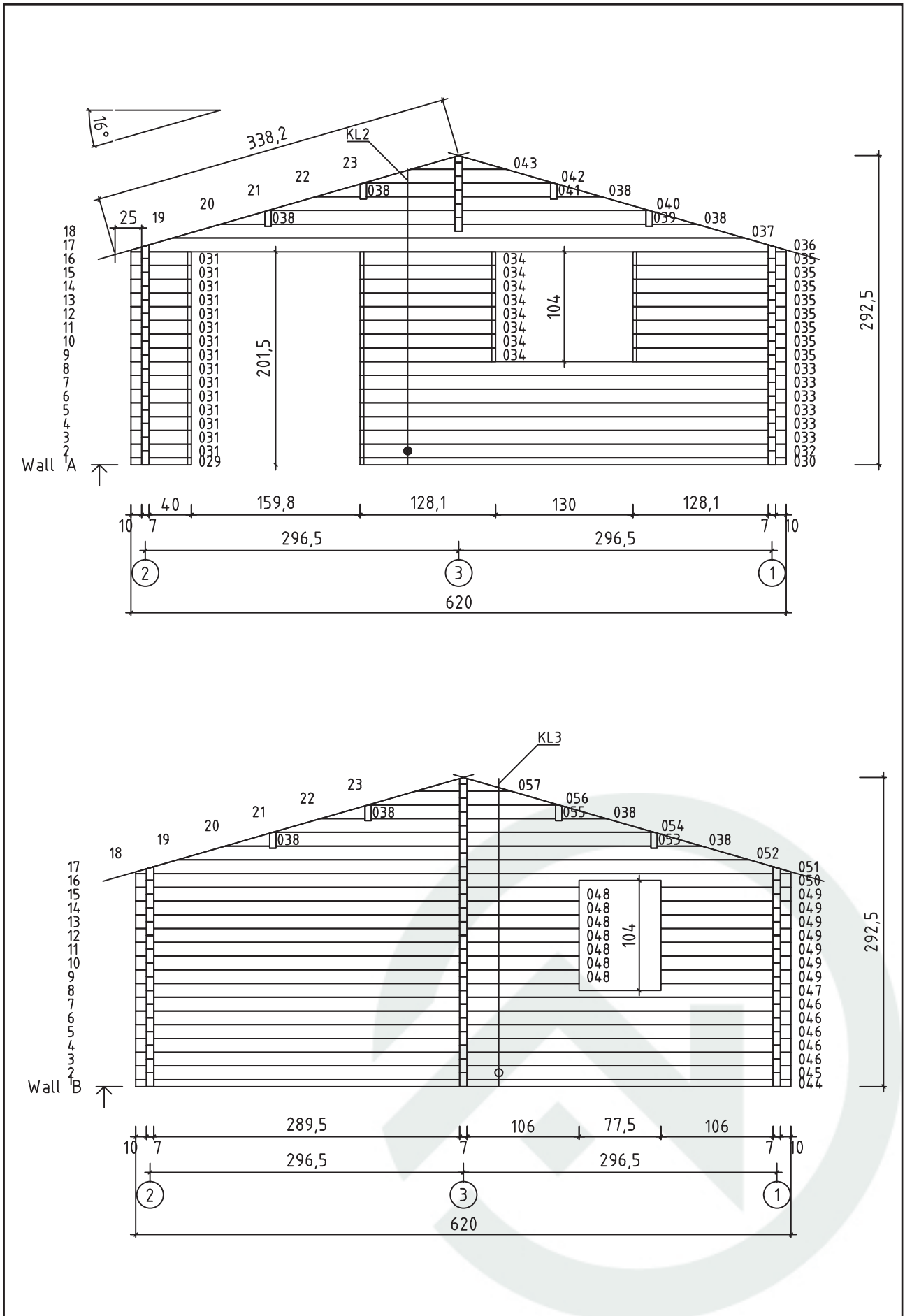

Wandplan C und D 871030

