

Technische Daten: Art.-Nr.: 870730

Wandaußenmaß: 450 x 360 cm

Bohlenstärke: 70 mm



Hammerfest 70-B. Durch Kunden farblich behandelt

Kontrolliert durch:

Achtung: Alle angegebenen Maße sind ca.-Maße!

3D-Darstellung und Grundriss 870730

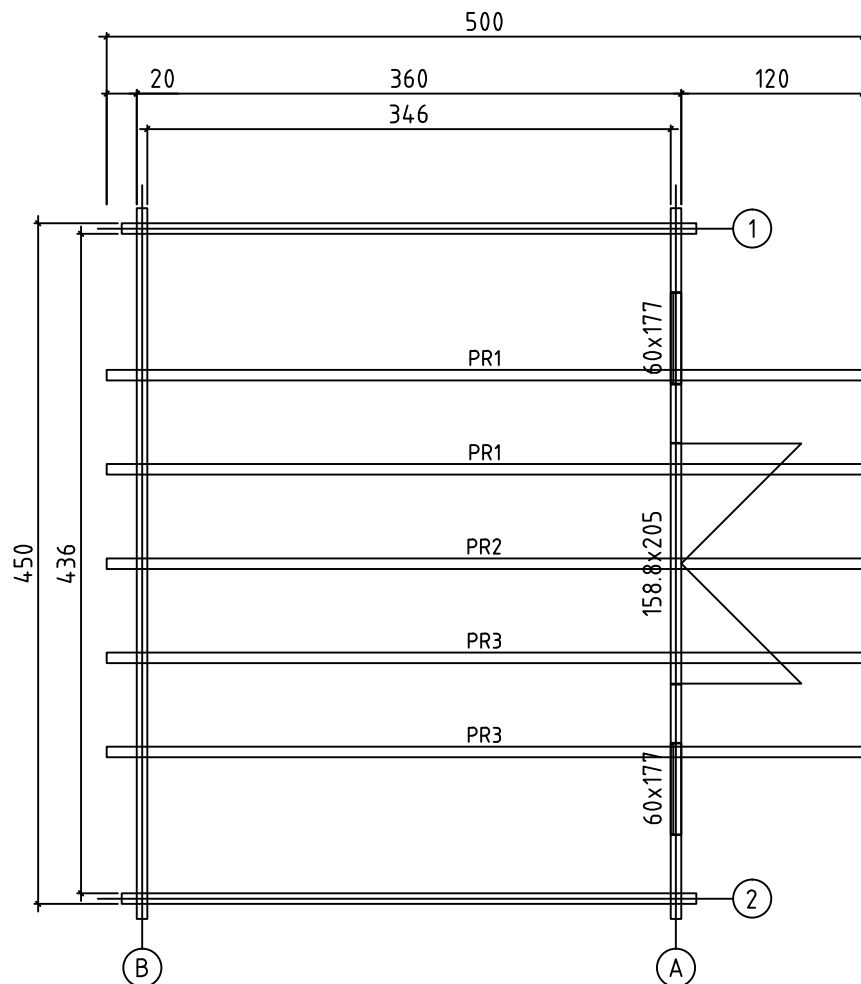
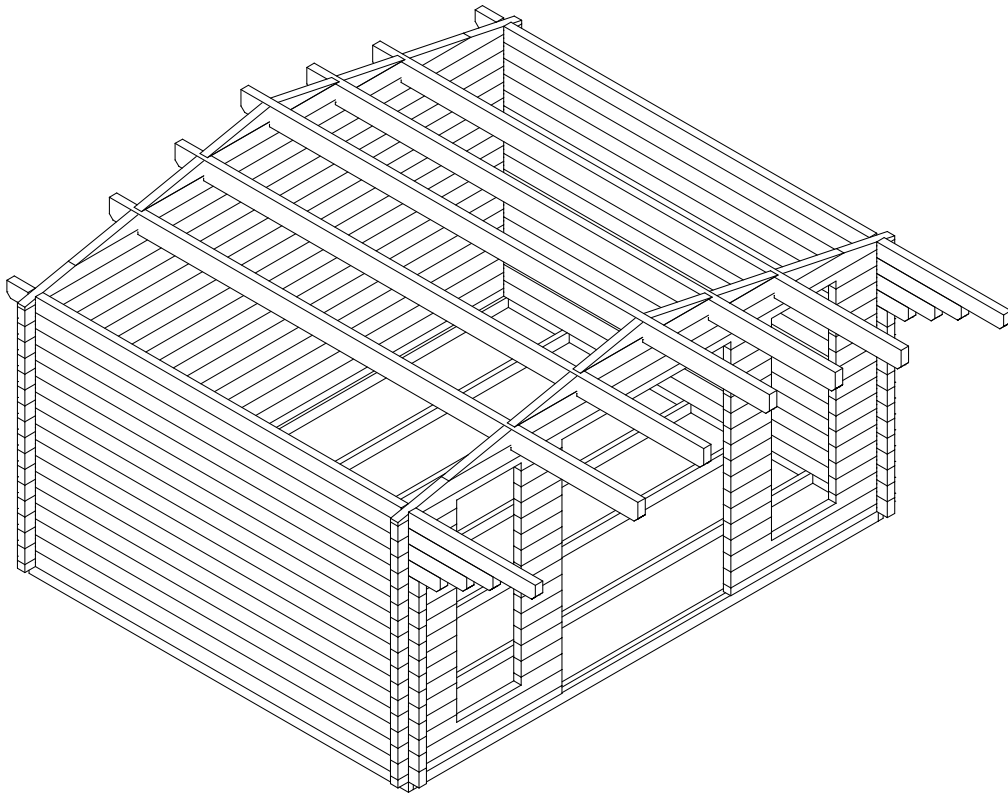





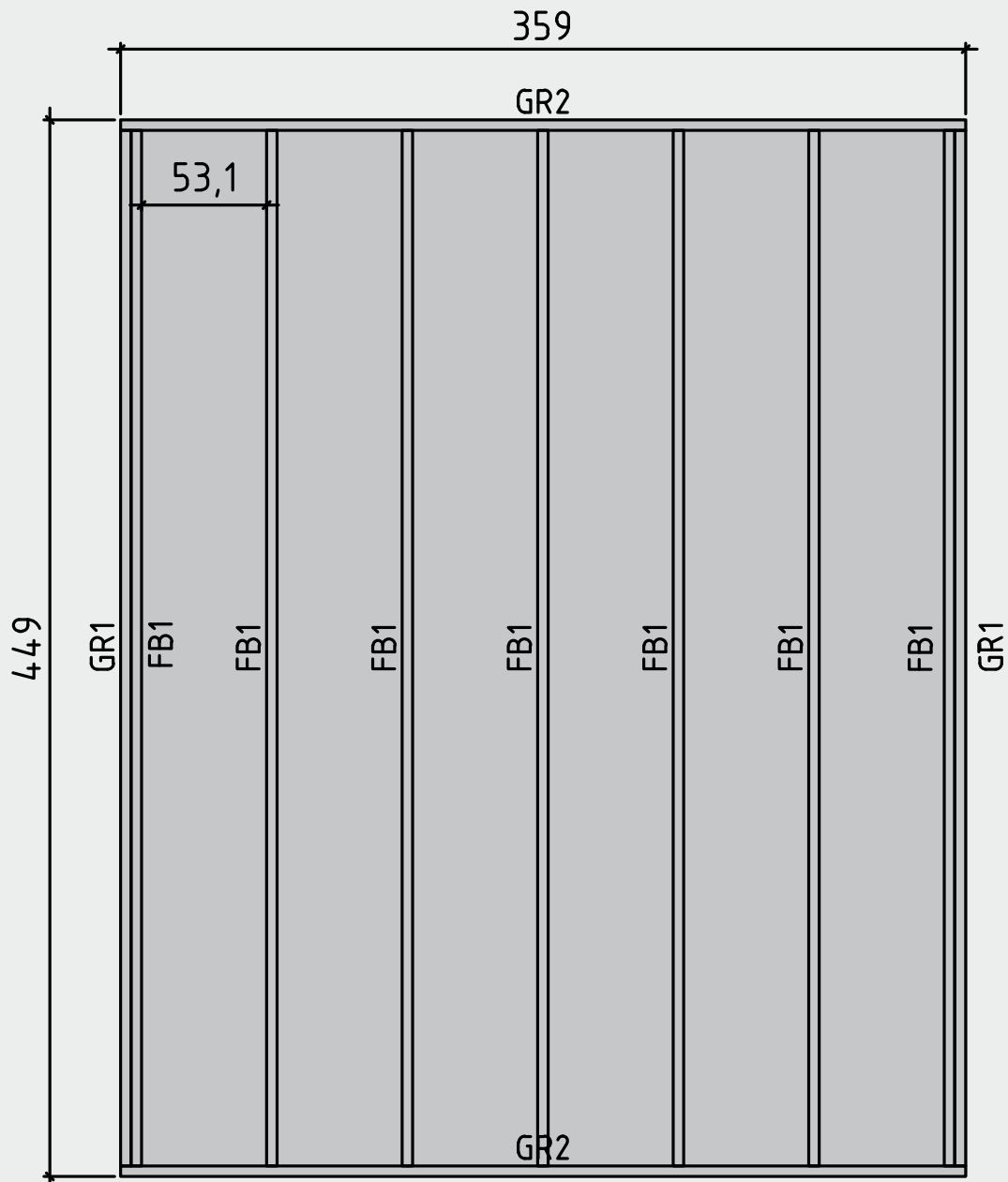

Lagerholzplan und Fundamentplan 870730

Wir empfehlen als Fundament für Ihr Gartenhaus eine vollflächig, festgegründete gepflasterte oder betonierte Fläche.
Wahlweise ist auch ein Punkt- oder Streifenfundament möglich.

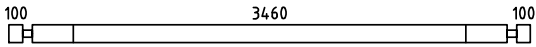
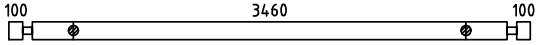
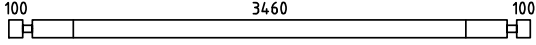
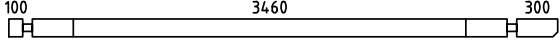
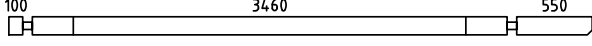
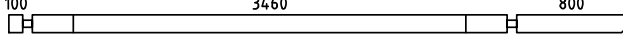
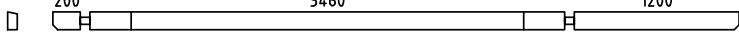
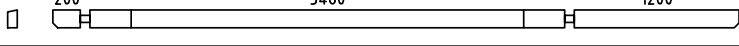
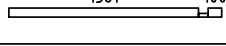
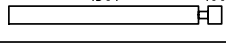
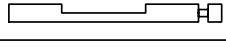

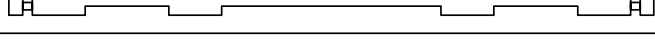
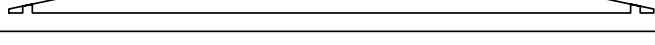
Teileliste 1

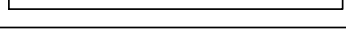
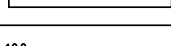
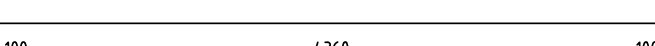
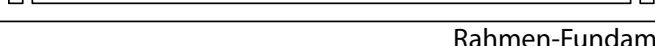
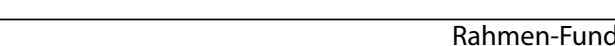
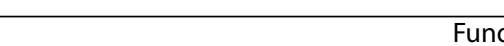
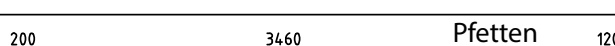
870730

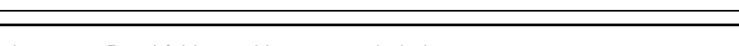
| Pos | | Quantity | Profil (mm) | Length (mm) |
|-----|--|----------|-------------|-------------|
| 001 |  | 2 | 70x130 | 3800 |
| 002 |  | 2 | 70x130 | 3800 |
| 003 |  | 22 | 70x130 | 3800 |
| 004 |  | 2 | 70x130 | 4000 |
| 005 |  | 2 | 70x130 | 4250 |
| 006 |  | 2 | 70x130 | 4500 |
| 007 |  | 1 | 70x130 | 5000 |
| 008 |  | 1 | 70x130 | 5000 |
| 009 |  | 2 | 70x65 | 1551 |
| 010 |  | 2 | 70x130 | 1551 |
| 011 |  | 2 | 70x130 | 1551 |
| 012 |  | 26 | 70x130 | 556 |
| 013 |  | 26 | 70x130 | 386 |
| 014 |  | 1 | 70x130 | 4700 |
| 015 |  | 2 | 70x130 | 4700 |
| 016 |  | 12 | 70x124 | 593 |
| 017 |  | 2 | 70x130 | 2431 |
| 018 |  | 2 | 70x130 | 1186 |
| 019 |  | 1 | 70x65 | 4700 |
| 020 |  | 16 | 70x130 | 4700 |
| GR1 |  | 2 | 45x90 | 4400 |
| GR2 |  | 2 | 45x90 | 3590 |
| FB1 |  | 7 | 45x90 | 4400 |
| PR1 |  | 2 | 70x170 | 5000 |
| PR2 |  | 1 | 70x170 | 5000 |

Teileliste 3

870730

| POS | ST. | B | H | L | Teileliste |
|------|---------------------|------|------|-----------------------|---|
| FB1 | Vt. spetsi | | | | FUNDMENTHOLZER |
| F1 | 15,1m ² | 28 | | 3455 | FUSSBODENBRETTER 50/39/32 |
| PR | 5 | 70 | 170 | 5000 | DACHBALKEN |
| RB1 | 25,55m ² | 20 | | 2555 | DACHBRETTER 116/90/74 |
| R1 | 2 | 20 | 120 | 5000 | Traufenbretter |
| R2 | 2 | 45 | 65 | 5000 | Traufenbretter |
| R3 | 4 | 20 | 120 | 2750 | Giebelabschlussleiste |
| R4 | 4 | 20 | 90 | 2750 | Giebelabschlussleiste |
| WN06 | 2 | 600 | 1770 | | <p>Schiebelamellen 30x30x1575 mm - 4 pcs.</p> |
| DR16 | 1 | 1588 | 2050 | | |
| P1 | 17m | 20 | 40 | | Fussbodenleiste |
| P2 | 6+6 | 20 | 90 | 2030 | Türleiste DR 16, Fensterleiste WN 06 |
| P3 | 2+2 | 20 | 90 | 900 | Fensterleiste WN 06 |
| P4 | 2+2 | 20 | 90 | 540 570 | Fensterleiste WN 06 |
| P5 | 1+1 | 20 | 90 | 1890 | Türleiste DR 16 |

Details 870730

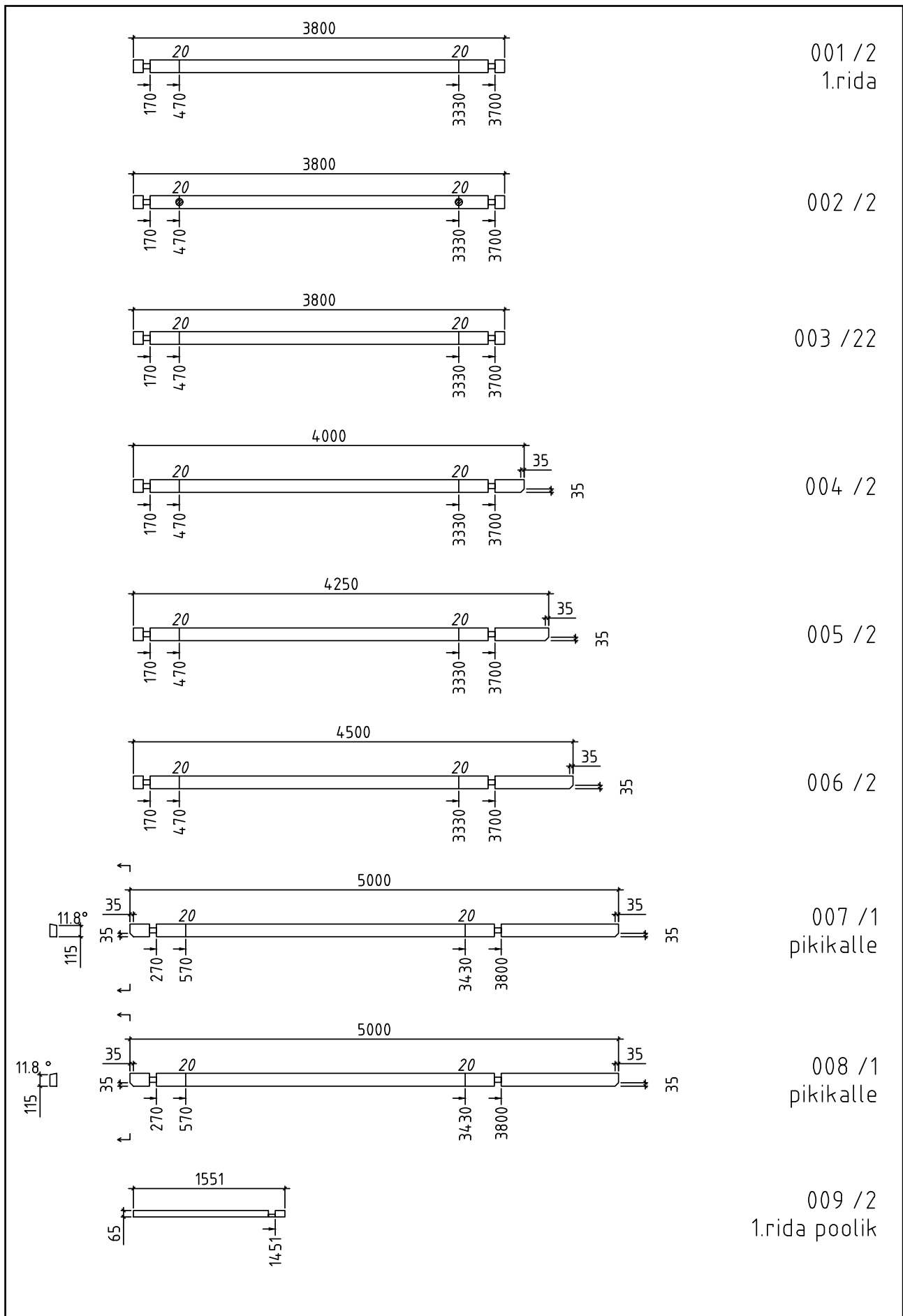

Details 870730

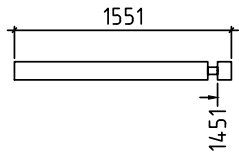

010 / 2

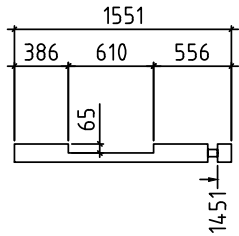

011 / 2

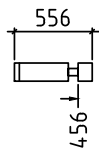

012 / 26



013 / 26

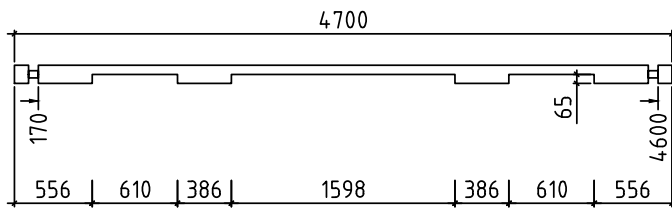

014 / 1

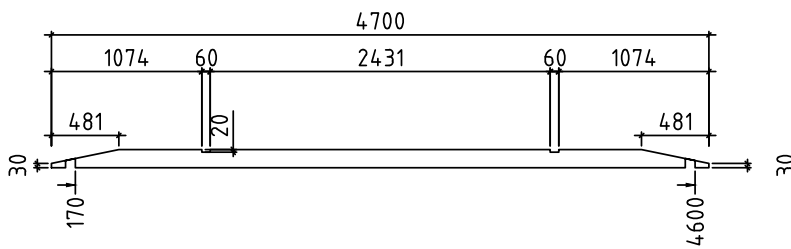

015 / 2
kelp

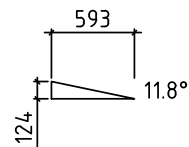

016 / 12
kelp

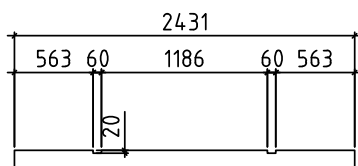

017 / 2

Details 870730

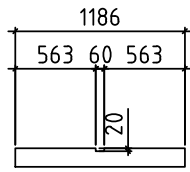

018 / 2

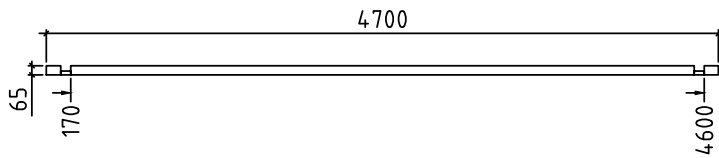

019 / 1
1.rida poolik

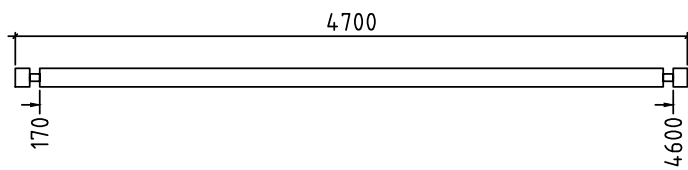

020 / 16

Details 870730

Rahmen-Fundamentholz

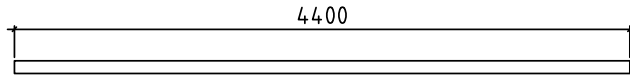

GR1 /2
45x90

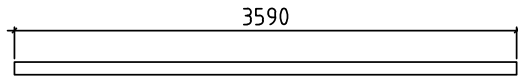

GR2 /2
45x90

Fundamentholz

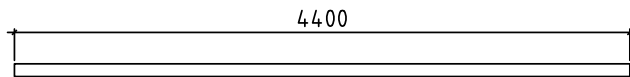

FB1 /7
45x90

Pfetten

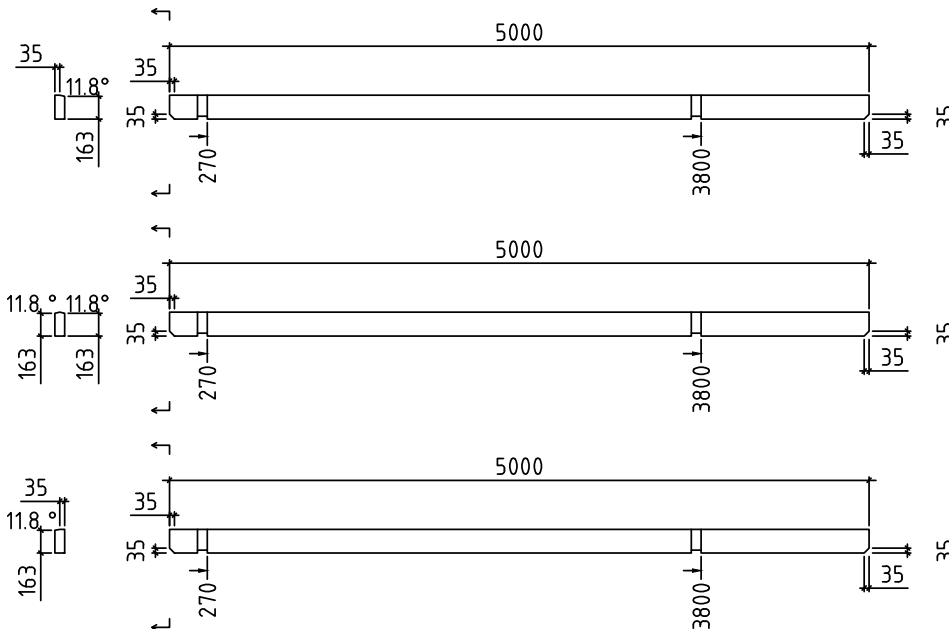

PR1 /2
70x170(60x150)

PR2 /1
70x170(60x150)

PR3 /2
70x170(60x150)

Wandplan 1 und 2 870730

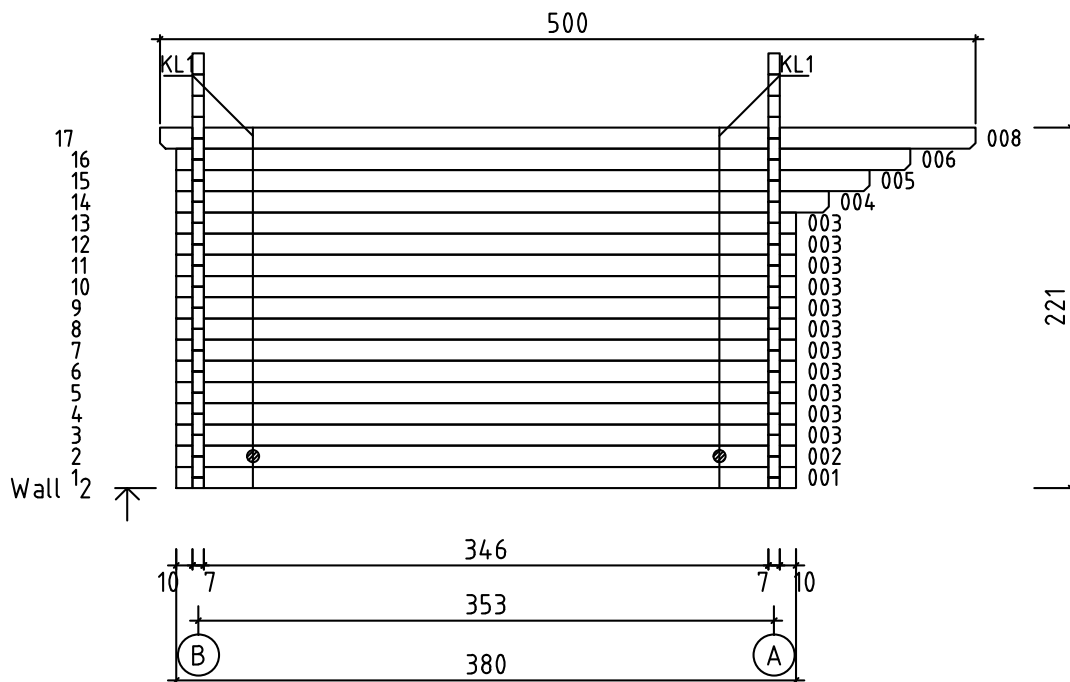
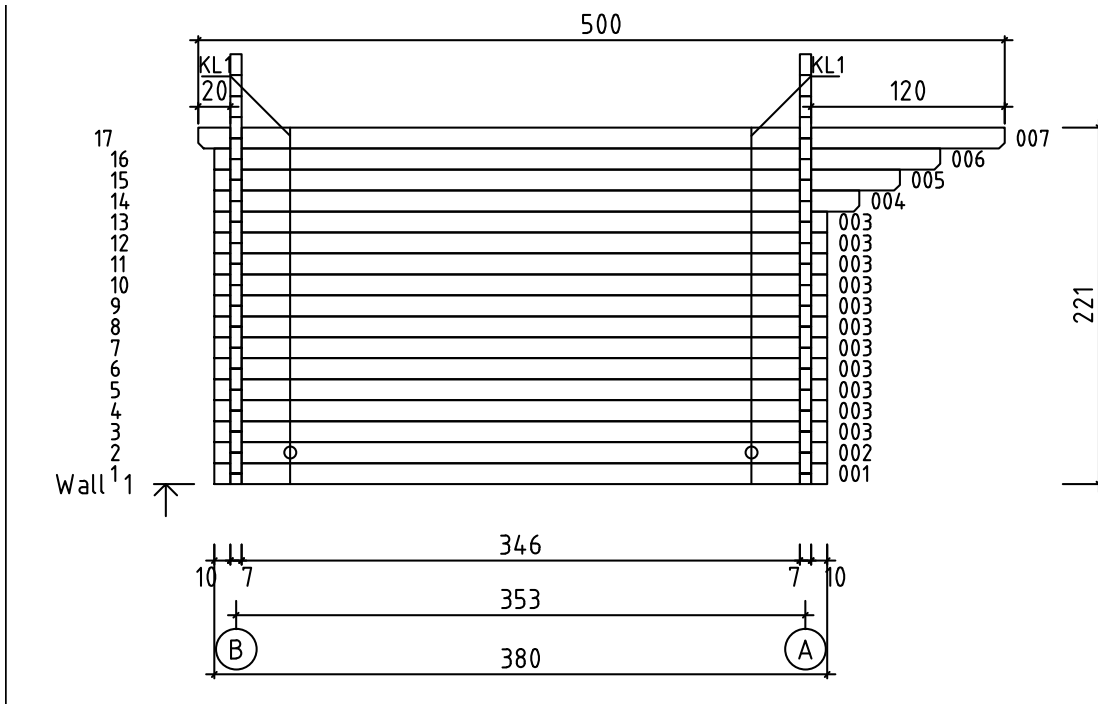

Wandplan A und B 870730

