

44031

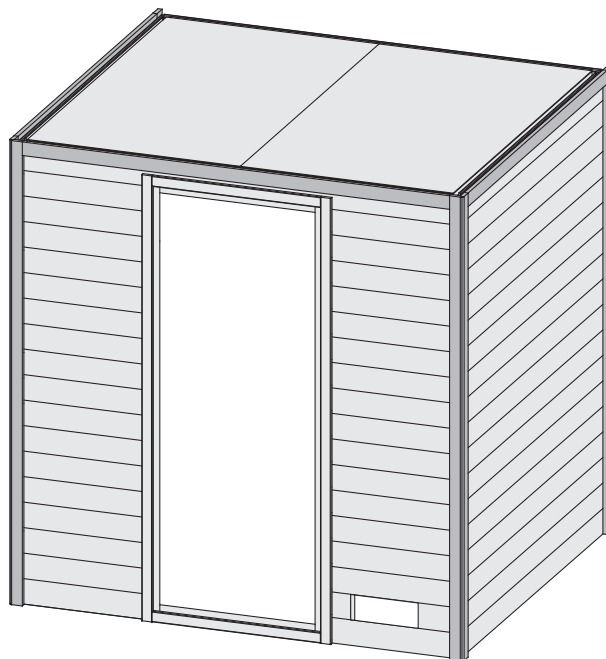

-  **Aufbauanleitung**
-  **Building Instructions**
-  **notice de montage**
-  **montagehandleiding**
-  **Montagevejledning**
-  **Instrucciones de construcción**
-  **Istruzioni per il montaggio**
-  **Montážní návod**

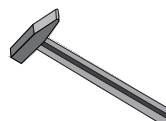

Werkzeuge / Tools*

X	
X	
X	
X	
X	
X	
X	
X	
X	

Technische Daten

In der Auftragsbestätigung bzw. Lieferschein ist der gekaufte Ofentyp bzw. das erworbene Steuergerät zu finden. Bitte entnehmen Sie die technischen Daten Ihrer Geräte der folgenden Auflistung

Gerät	Netzspannung	Wattage
Öfen		
9kW Ofen Bio	400V ~ 3N	9kW
9kW Ofen (Finnisch)	400V ~ 3N	9kW
9kW Ofen integr. Steuerung	400V ~ 3N	9kW
4,5kW Ofen Bio	400V ~ 3N	4,5kW
4,5kW Ofen (Finnisch)	400V ~ 3N	4,5kW
4,5kW Ofen integr. Steuerung	400V ~ 3N	4,5kW
3,6kW Ofen Bio	230V ~ 1N	3,6kW
3,6kW Ofen (Finnisch)	230V ~ 1N	3,6kW
3,6kW Ofen integr. Steuerung	230V ~ 1N	3,6kW
Steuergeräte		
externe Steuerung Easy Bio	400V ~ 3N	max. 10,8kW
externe Steuerung Plug&Play Bio	240V ~ 3N	max. 10,8kW
externe Steuerung (Finnisch)	400V ~ 3N	max. 10,8kW
externe Steuerung Plug&Play (Finnisch)	240V ~ 3N	max. 10,8kW
Multisteuergerät	400V ~ 3N	max. 10,5kW
externe Steuerung Classic Bio	400V ~ 3N	max. 9kW
externe Steuerung Classic (Finnisch)	400V ~ 3N	max. 9kW
externe Steuerung Premium Bio	400V ~ 3N	max. 12kW
externe Steuerung Premium (Finnisch)	400V ~ 3N	max. 9kW



Vergleichen Sie zuerst die Material-liste mit Ihrem Paketinhalt! Bitte haben Sie Verständnis, dass Beanstandungen nur im nicht aufgebauten Zustand bearbeitet werden können!



Vergelijk eerst de lijst van materialen met de inhoud van uw pakket! Reclamaties kunnen alleen in behandeling worden genomen zolang de onderdelen nog niet zijn gemonteerd!



Confrontate questa distinta materiali prima con il contenuto del pacchetto! Vi preghiamo di comprendere che eventuali reclami possono essere accolti solo prima del montaggio!



First compare the list of materials with your package contents! Please understand that complaints can be processed in the non-built status only!



Start med at kontrollere materialelisten med indholdet af den leverede pakke! Vi gør venligst opmærksom på at reklamationer kun kan behandles for materialer som ikke er blevet bearbejdet!



Nejprve přezkontrolujte obsah balení podle materiálového listu! Mějte pochopení pro to, že případnou reklamaci se můžeme zabývat pouze tehdy, když díly nebudou smontované! Za pomoci tohoto seznamu můžete jednotlivé díly přiřadit k montážnímu návodu.



Commencez par comparer la liste du matériel avec le contenu de votre paquet! Sachez que nous traitons uniquement les réclamations concernant le matériel à l'état non monté!

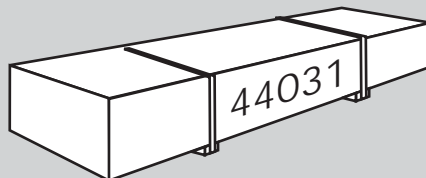
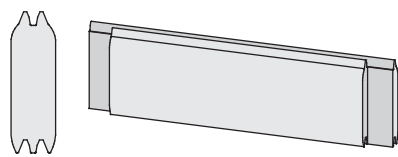

En primer lugar, compare la lista de material con el contenido del paquete. Rogamos entienda que las reclamaciones sólo pueden ser tramitadas antes de montar el objeto!

36 x A1	1628 x 121 x 38mm	ID 26150
18 x A2	1881 x 121 x 38mm	ID 21429

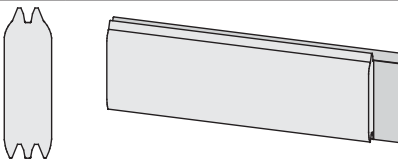

1 x A3	135 x 121 x 38mm	ID 80228
16 x A4	545 x 121 x 38mm	ID 21868

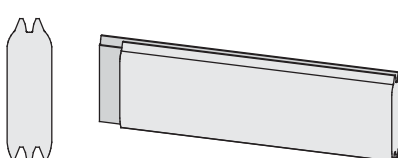

17 x A5	545 x 121 x 38mm	ID 21876
---------	------------------	----------

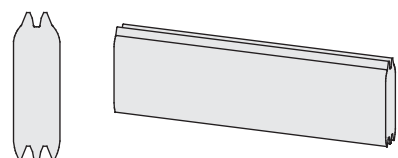

1 x A6	135 x 121 x 38mm	ID 80224
--------	------------------	----------

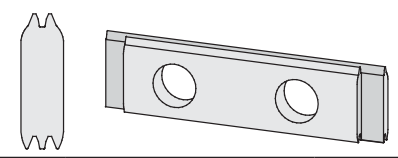

1 x A7	1881 x 121 x 38mm	ID 21864
--------	-------------------	----------

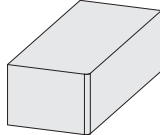

4 x C1	60 x 36 x 36mm	ID 5512
--------	----------------	---------

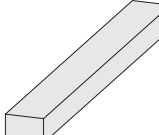

1 x B1	1920 x 20 x 3mm	ID 20799
2 x B2	1810 x 90 x 16mm	ID 71513
2 x B3	800 x 45 x 18mm	ID 24796
5 x B4	2000 x 58 x 18mm	ID 48541
1 x B5	300 x 95 x 18mm	ID 19130
4 x B6	480 x 95 x 18mm	ID 20930
4 x B7	565 x 95 x 18mm	ID 15498
3 x B8	1985 x 140 x 26mm	ID 38846
2 x B9	800 x 58 x 28mm	ID 15493
4 x B10	1973 x 36 x 36mm	ID 21826

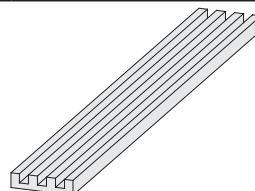

1 x E1	1820 x 140 x 26mm	ID 26480
--------	-------------------	----------

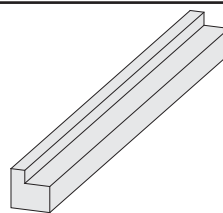

2 x E2	555 x 45 x 45mm	ID 40301
2 x E3	900 x 45 x 45mm	ID 47606

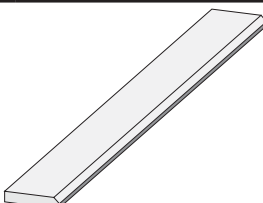

4 x E4	2000 x 58 x 18mm	ID 48545
--------	------------------	----------

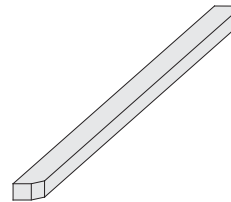

2 x E5	1556 x 38 x 28mm	ID 44352
2 x E6	1809 x 38 x 28mm	ID 44351

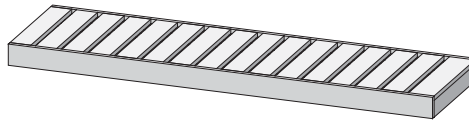

2 x L1	1810 x 550 x 90mm	ID 43994
--------	-------------------	----------

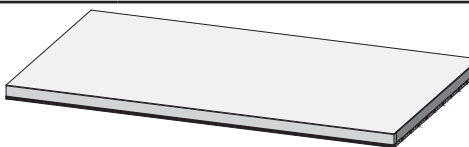

2 x M1	1665 x 955 x 94mm	ID 64246
--------	-------------------	----------



20 x	4 x 30mm	ID 3686
60 x	4 x 35mm	ID 3687
300 x	4 x 40mm	ID 21925
20 x	4 x 50mm	ID 3688
30 x	4 x 70mm	ID 3689
2 x	6 x 60mm	ID 14014
30 x	6 x 80mm	ID 47558
110 x	6 x 90mm	ID 26715

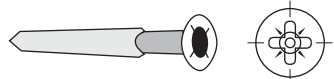

50 x	4,5 x 40mm	ID 26285
------	------------	----------

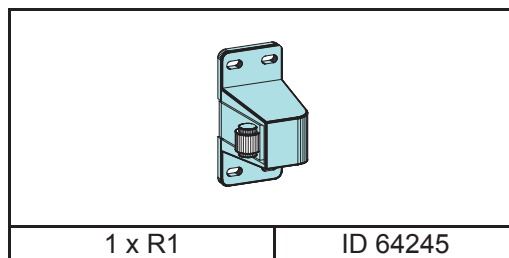
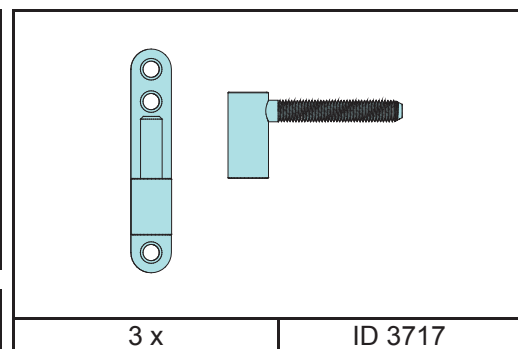
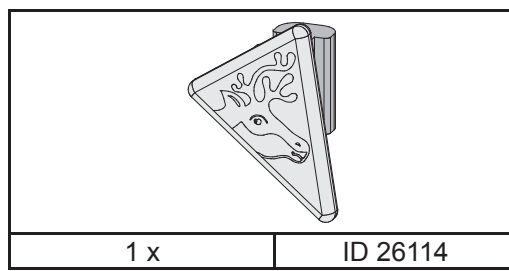
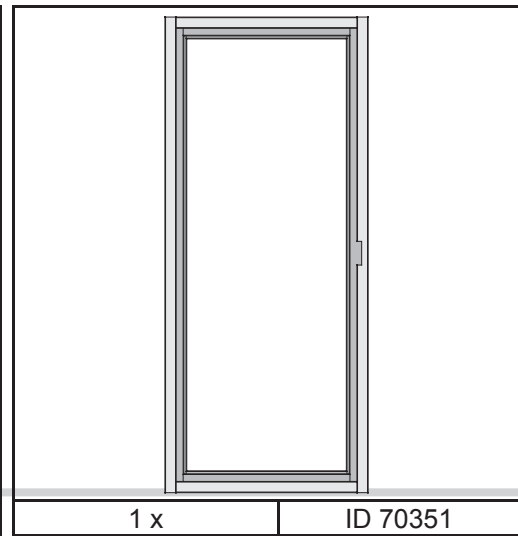
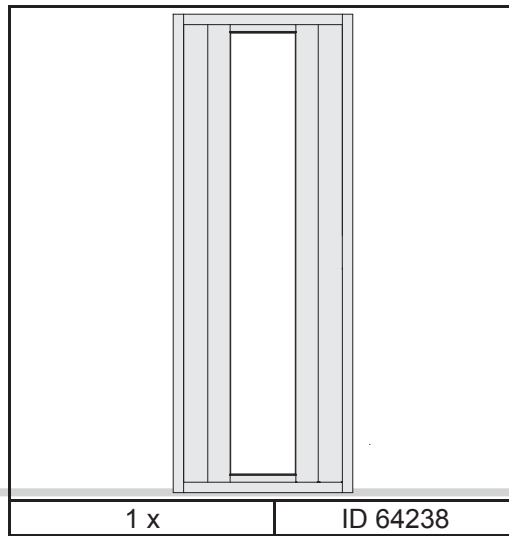
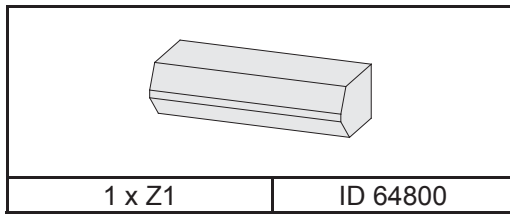
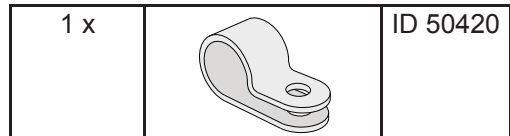
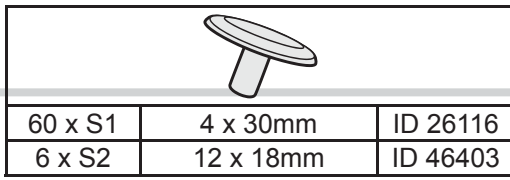
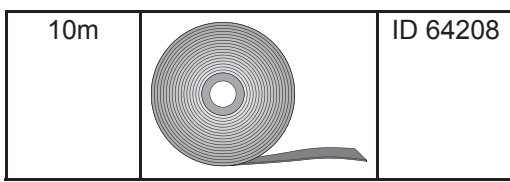
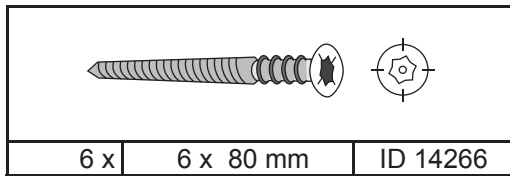

↑ ↓ >10cm

↑ ↓ >10cm

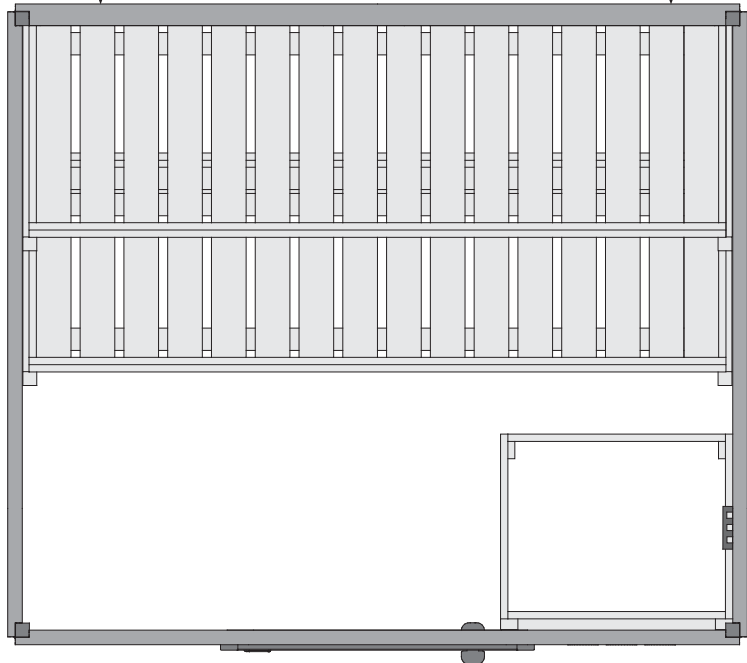

-  Draufsicht
-  Top view
-  vue de dessus
-  bovenaanzicht
-  vista desde arriba
-  vista desde arriba
-  vista dall'alto
-  pŕodorys

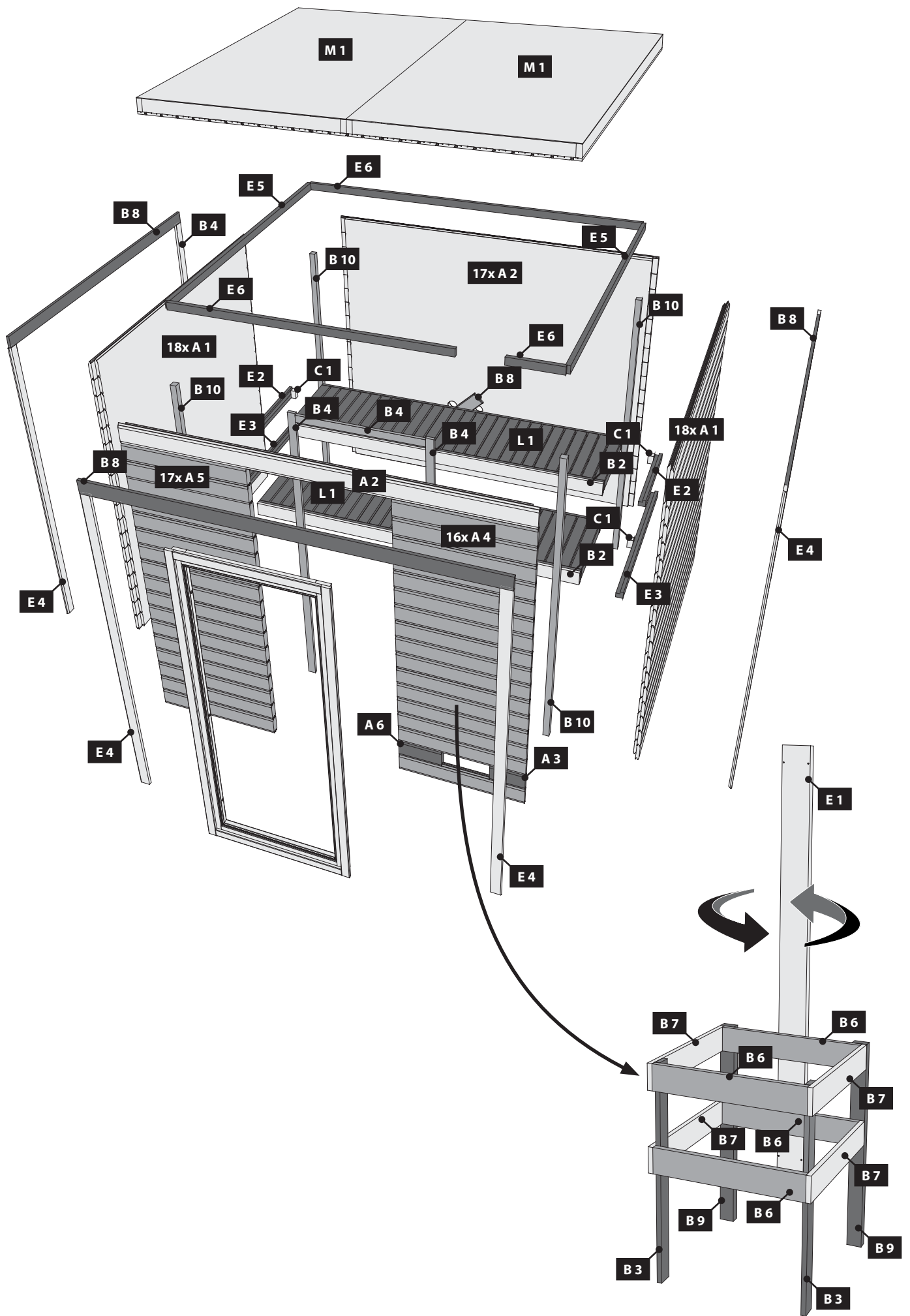

01

2x

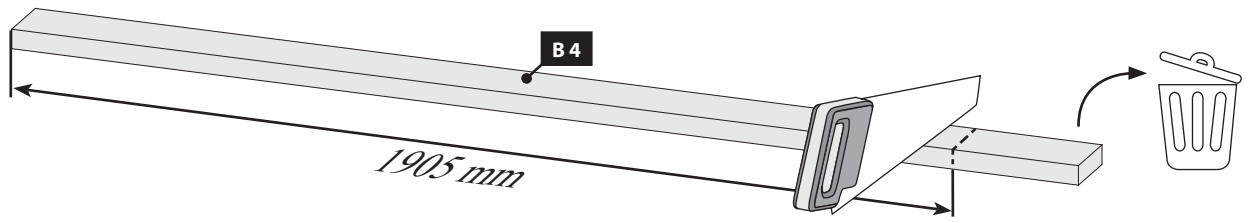

02

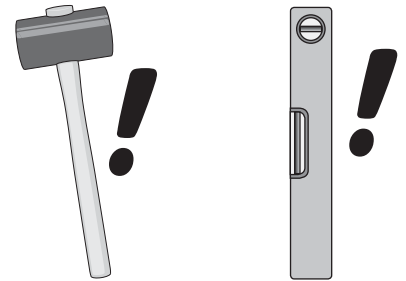
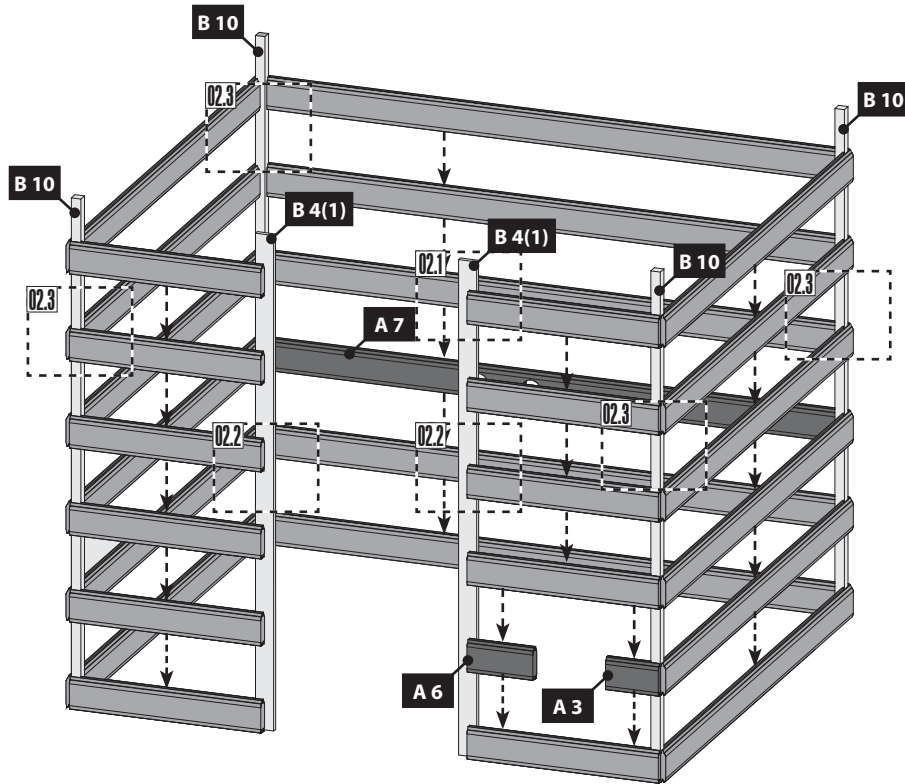

02.3

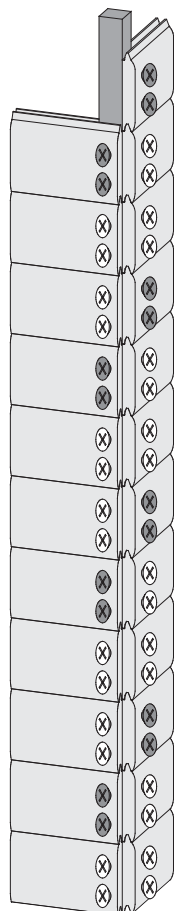
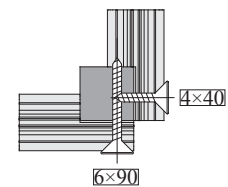
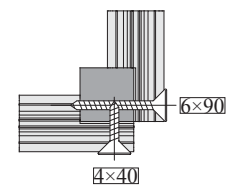

02.1

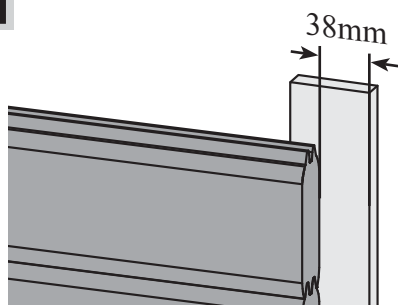

02.2

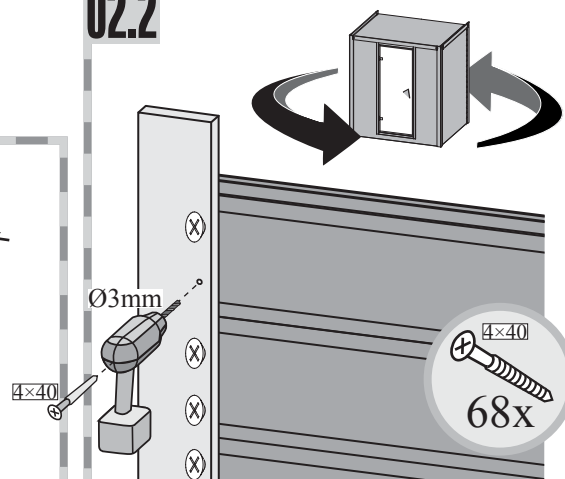

- Achten Sie auf die gleiche Höhe
- Look for the same height
- Faites attention à la même hauteur
- Besteed aandacht aan de dezelfde hoogte
- Prestar atención a la misma altura
- Prestare attenzione alla stessa altezza
- Dávejte pozor na stejnou výšku

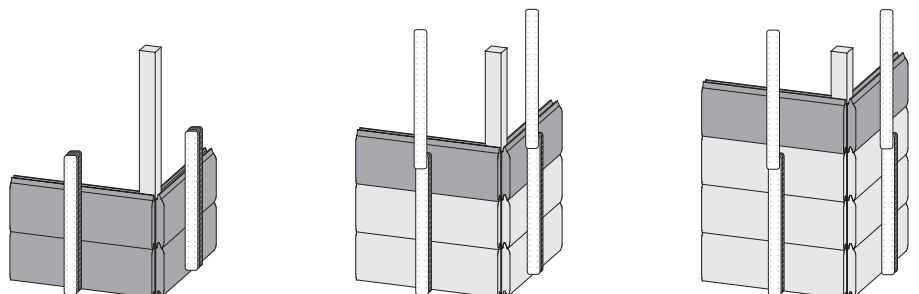

03.1

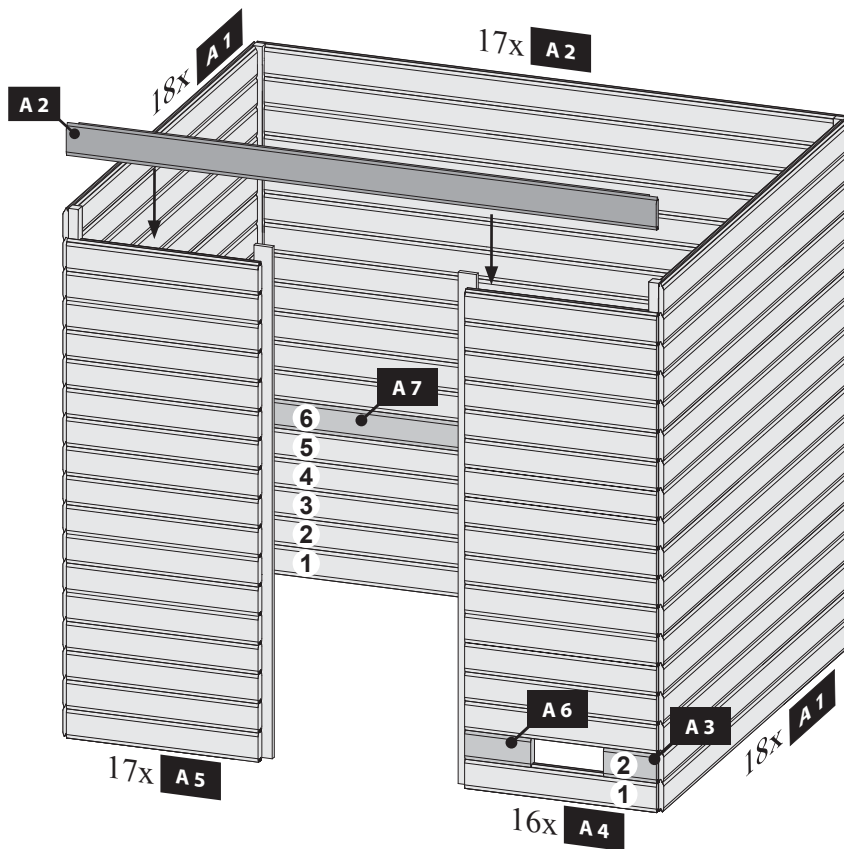

03.2

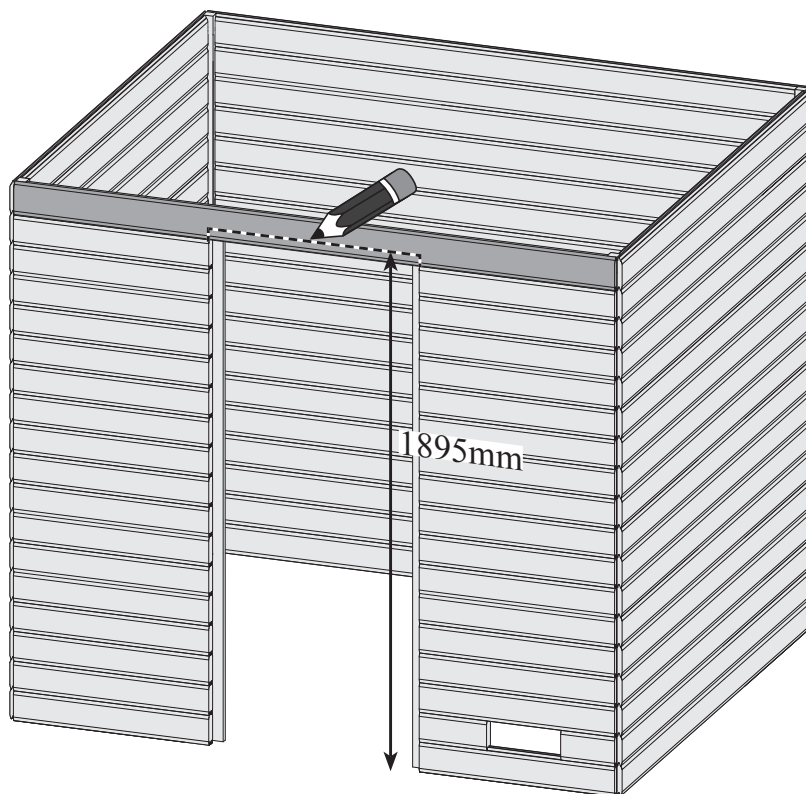

03.3

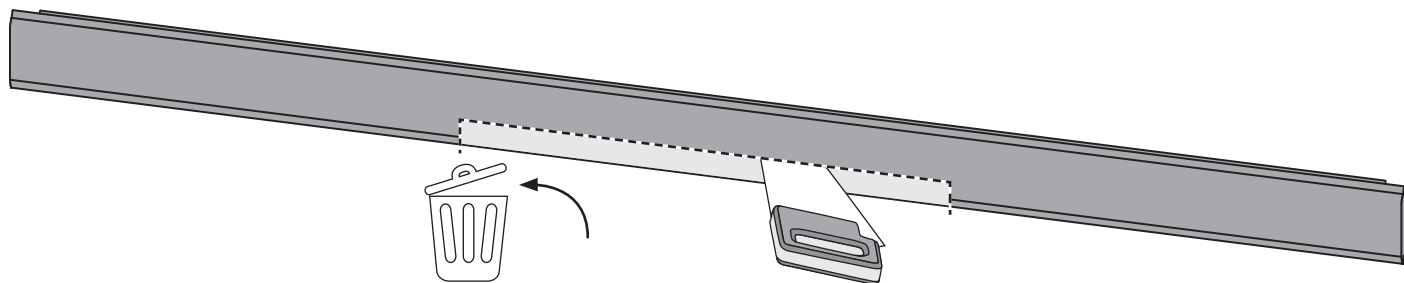

03.4

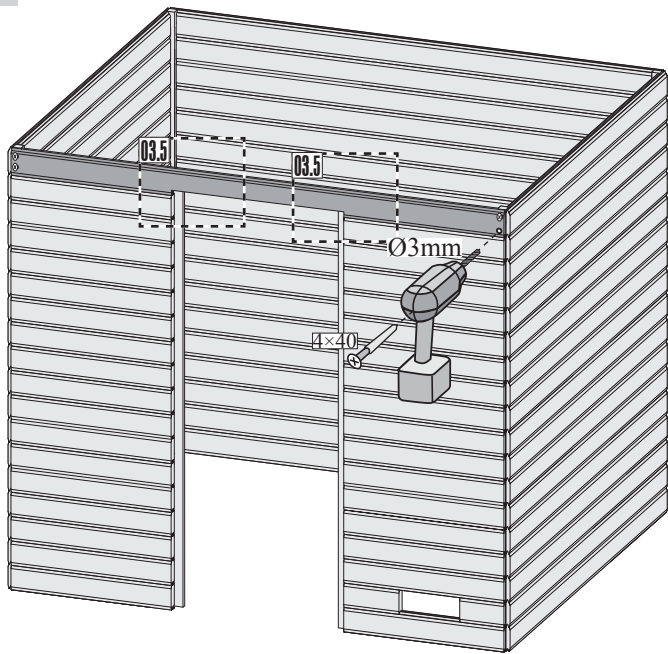

03.5

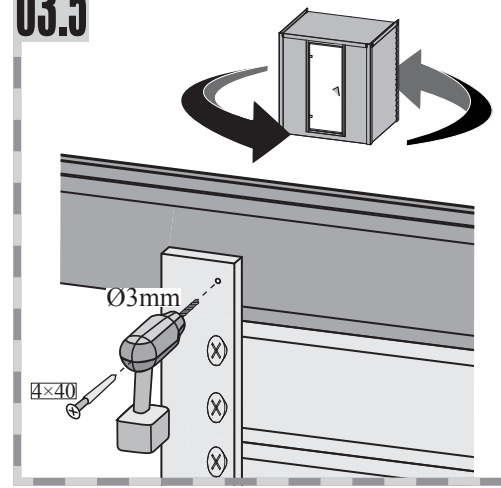

04

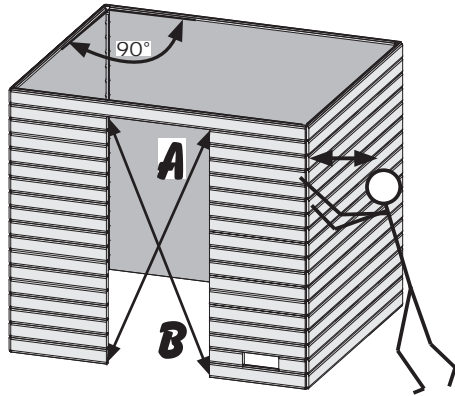

!!! A=B !!!

05

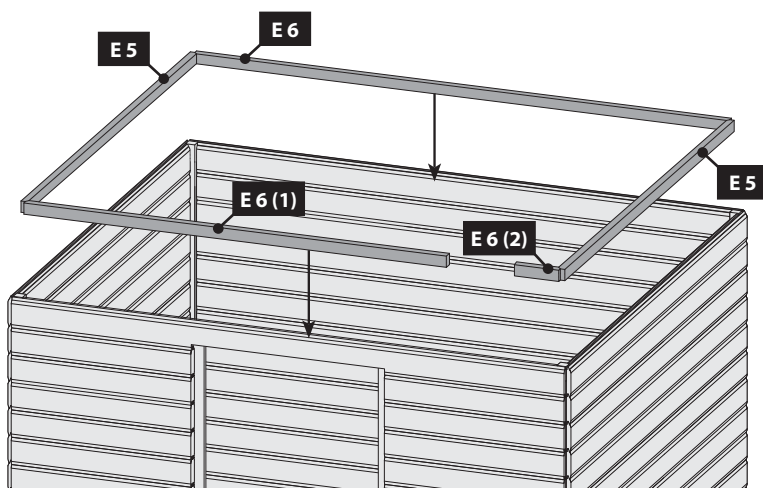
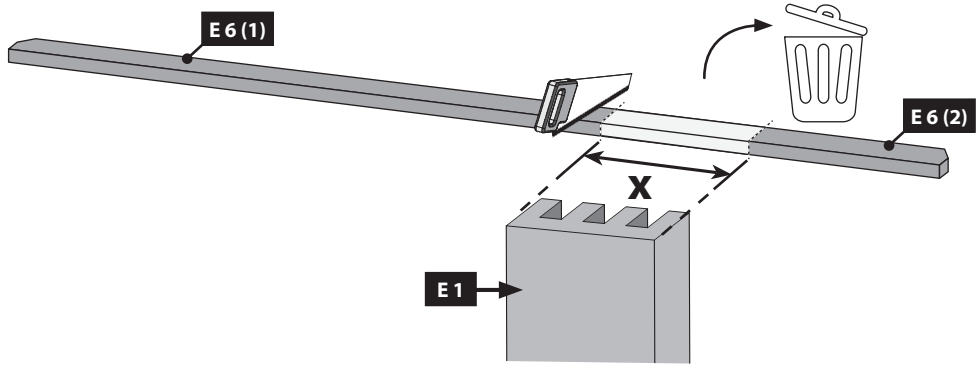

06

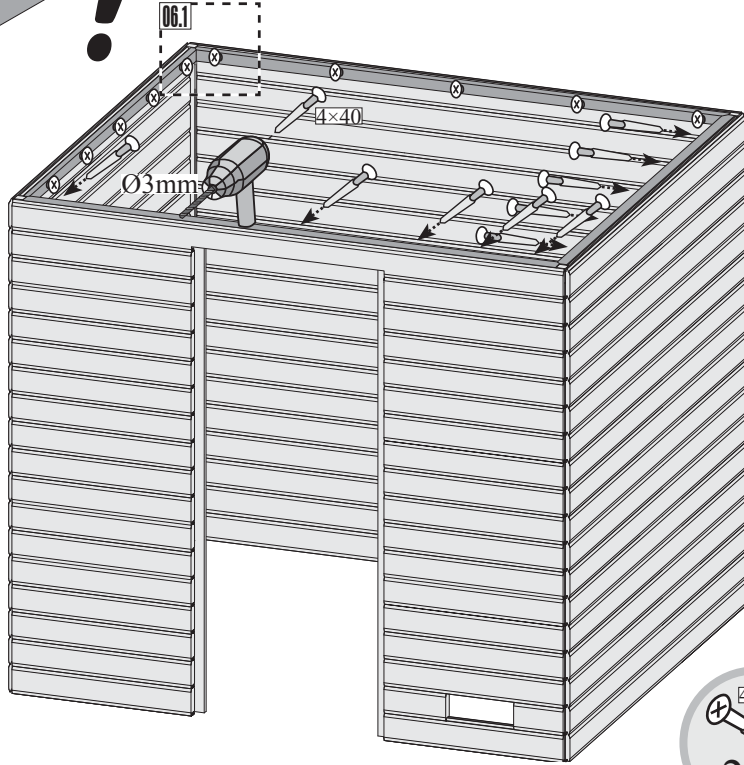
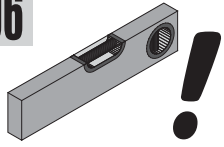

06.1

Bündig!
Affleurement!
Gelijk!
Aras!
Flush!
Combacia!
Stejný!

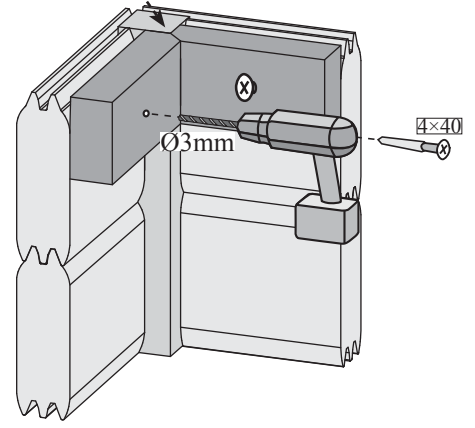

07

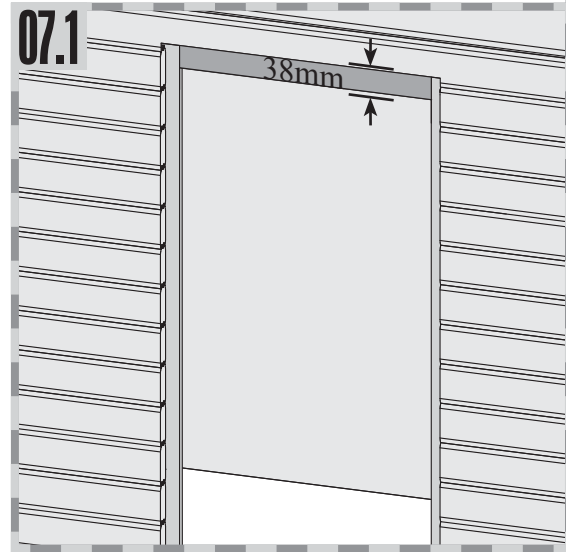
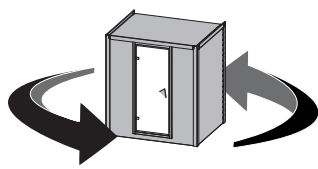
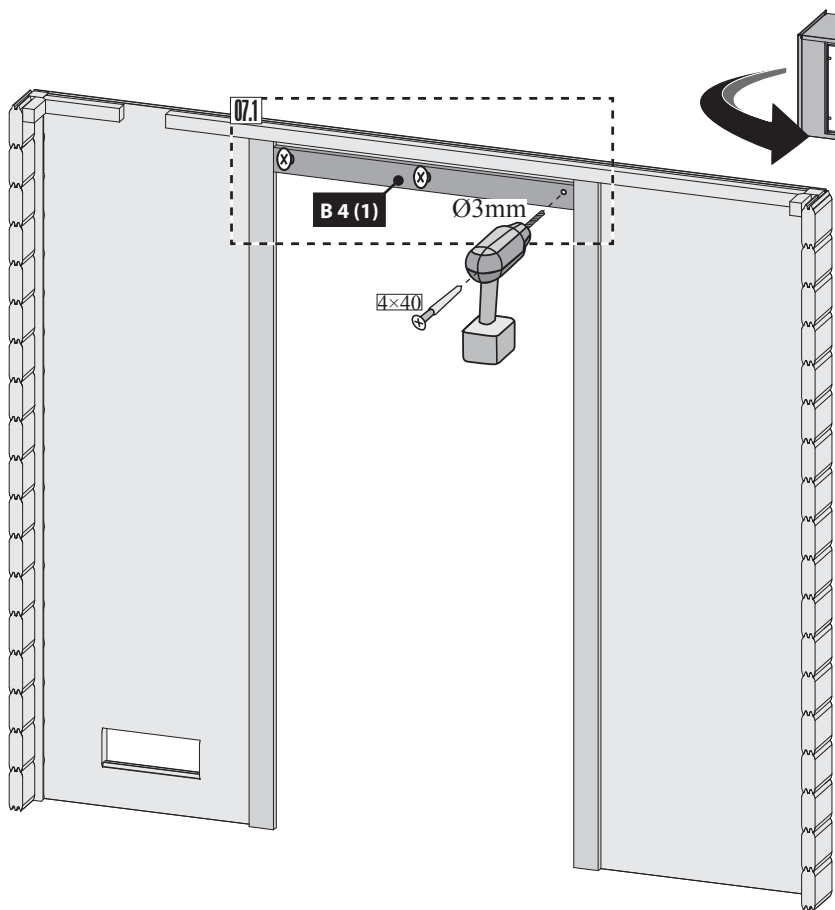
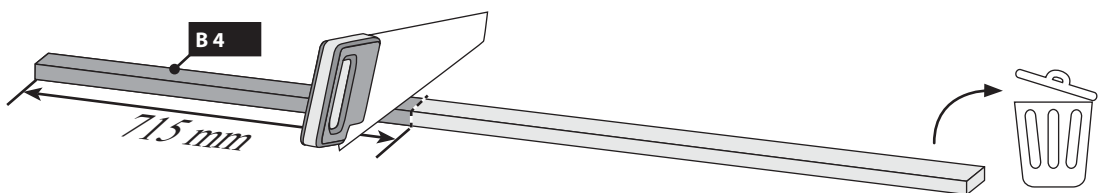

-  Tür in den Rahmen legen
-  Put the door in the frame
-  Mettez la porte dans le cadre
-  Plaats de deur in het frame
-  Sæt døren i rammen
-  Pon la puerta en el marco
-  Metti la porta nel telaio
-  Vložte dveře do rámu

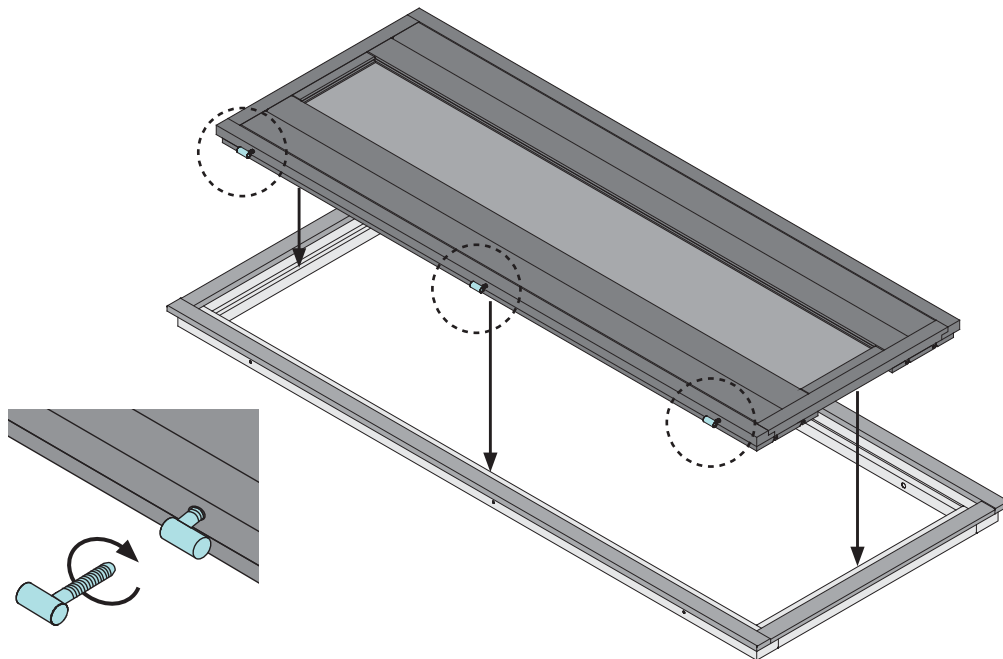

-  Tür im Rahmen ausrichten
-  Center the door in the frame
-  Aligner la porte dans le cadre
-  Lijn de deur in het frame uit
-  Juster døren i rammen
-  Alinea la puerta en el marco
-  Allinea la porta nella cornice
-  Zarovnejte dveře do rámu

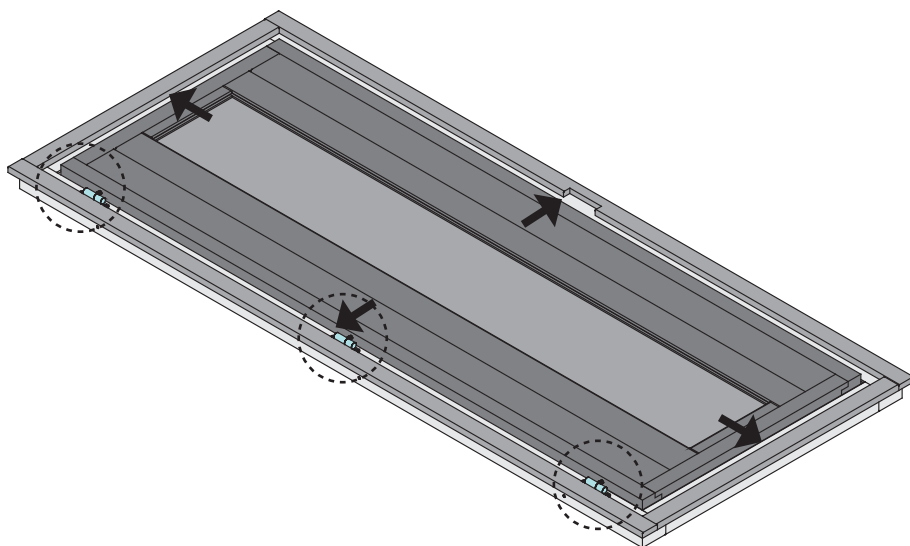

1.

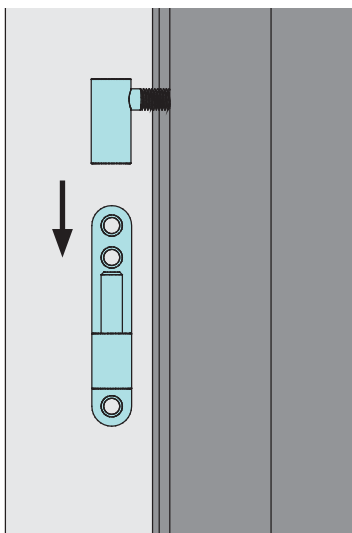

2.

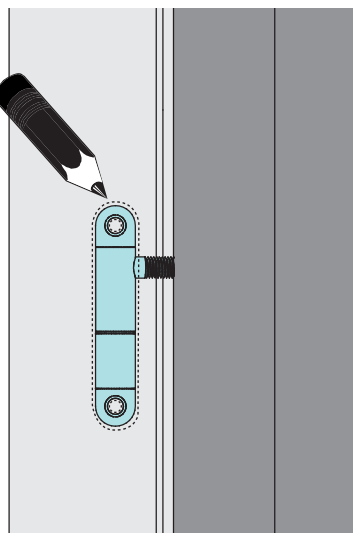

3.

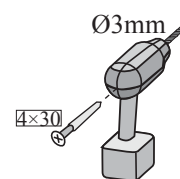
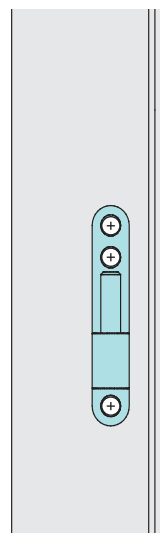

1.

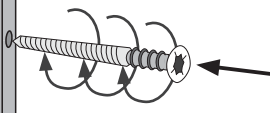
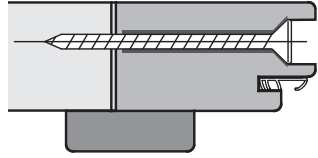
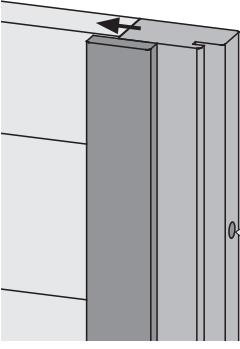

2.

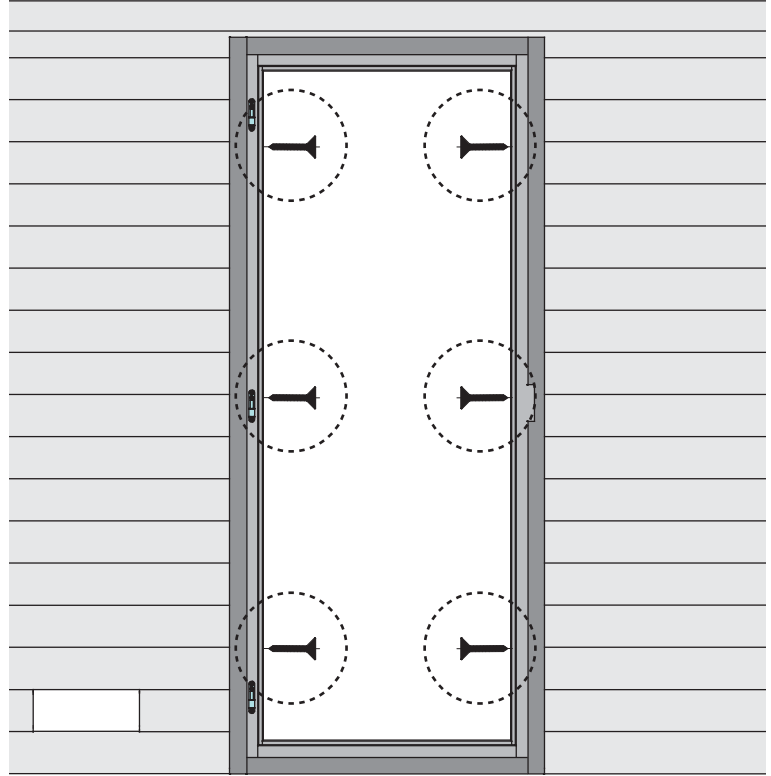
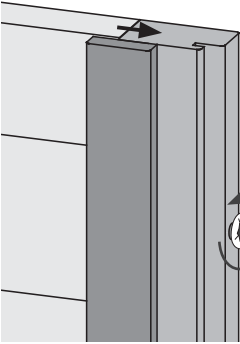

1.

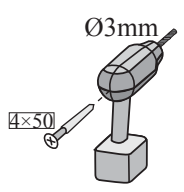
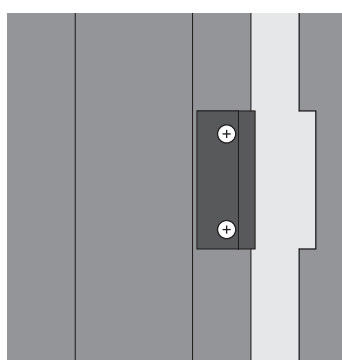
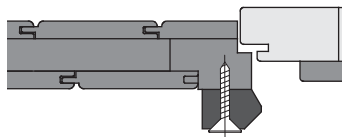

2.

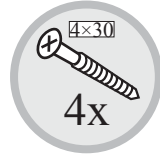
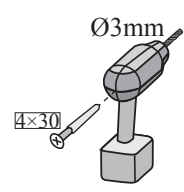
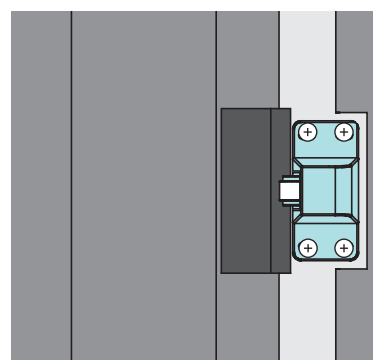
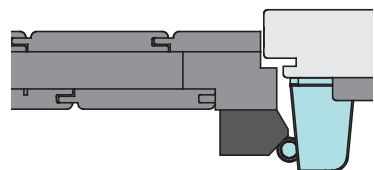

3.

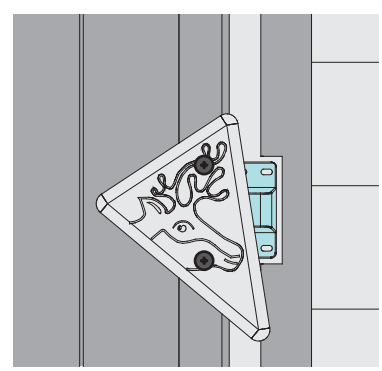
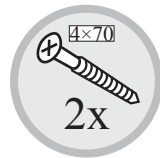
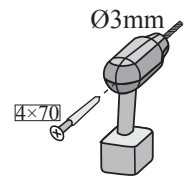
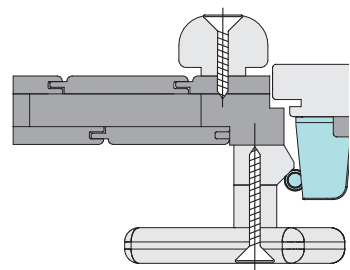
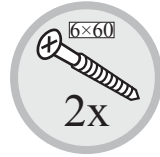
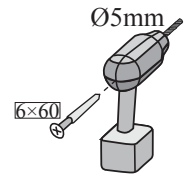
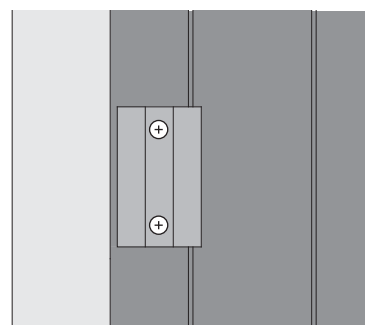
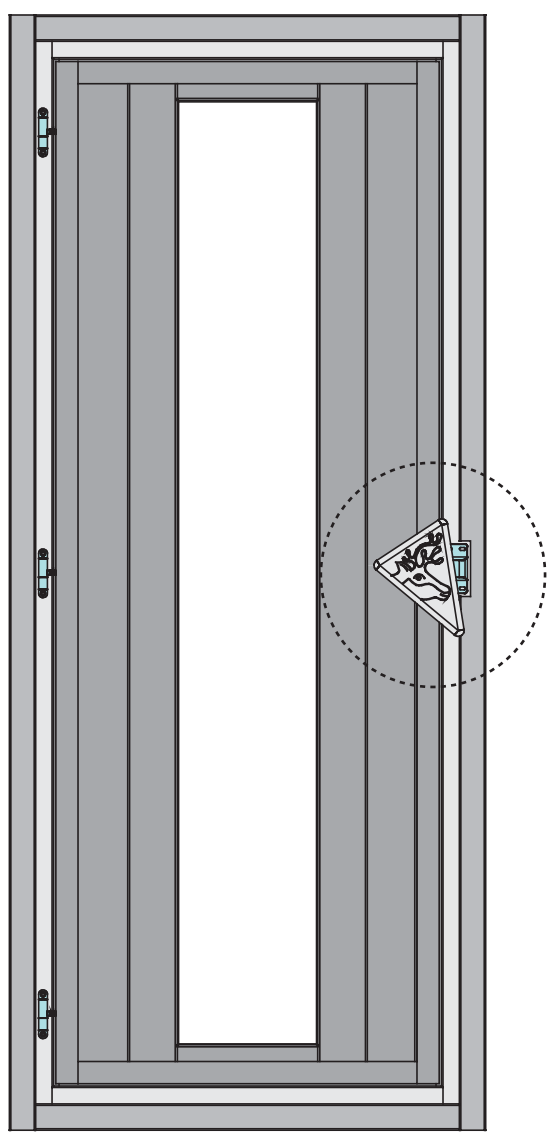

12

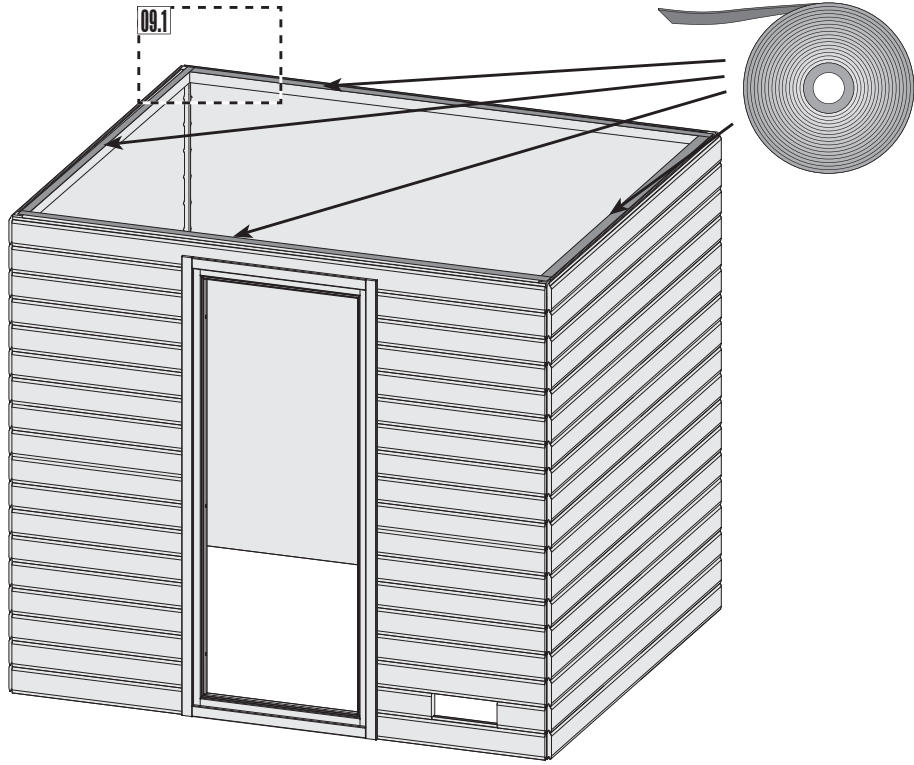

12.1

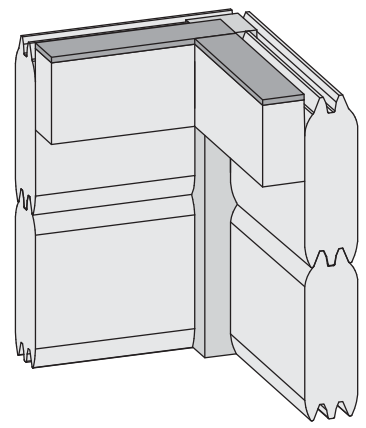

13

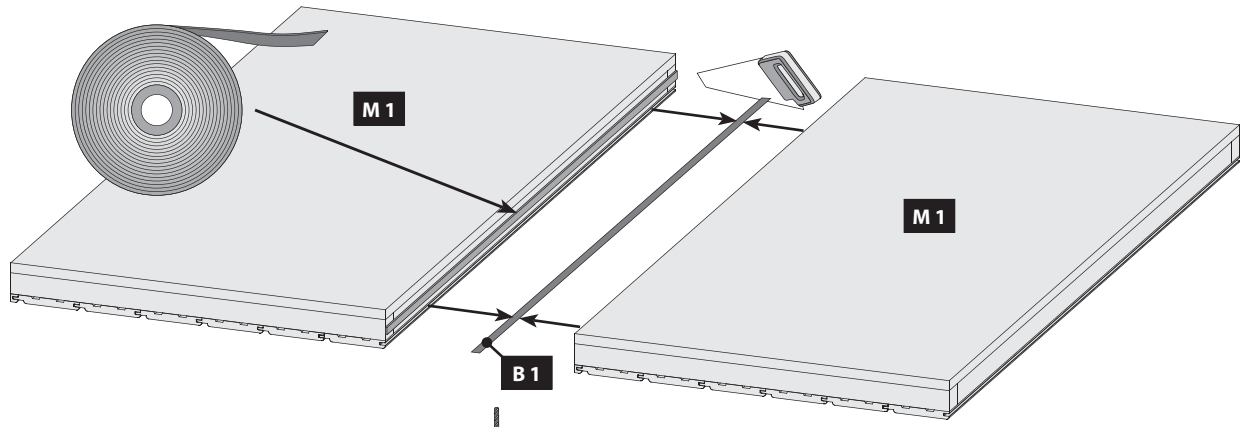

14

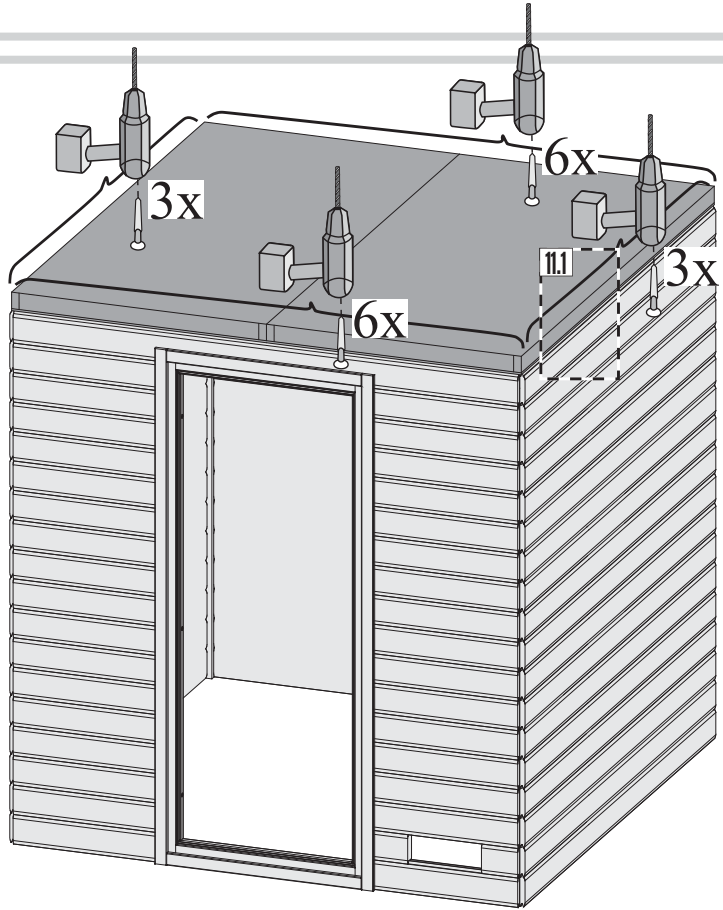

14.1

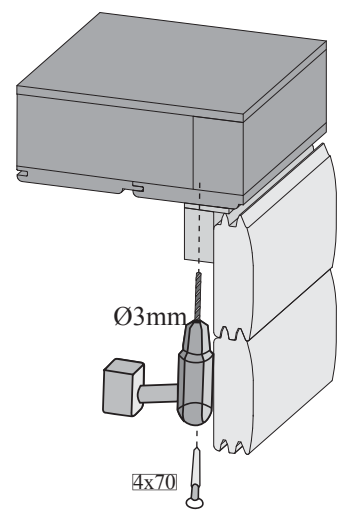

15 2x

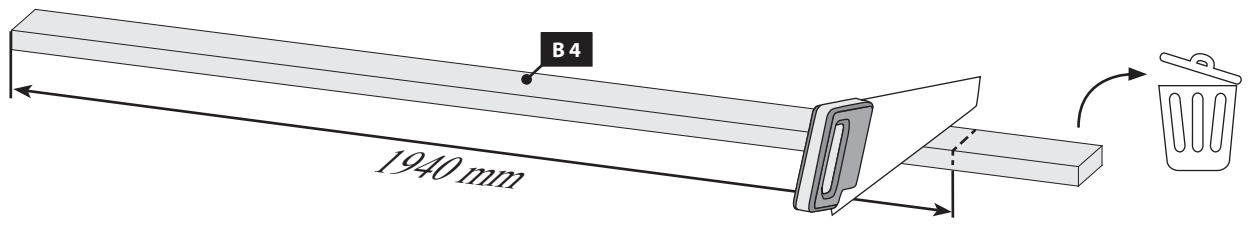

16 4x

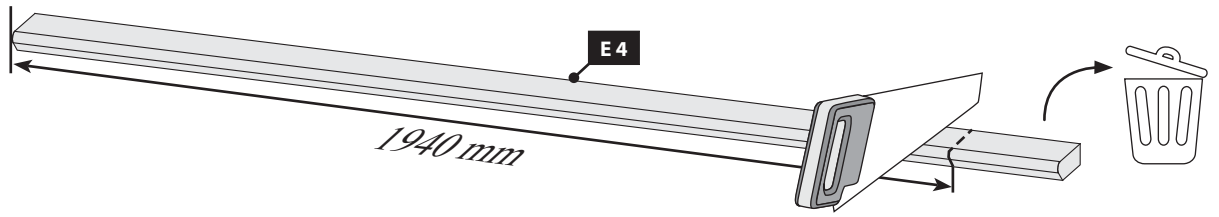

17

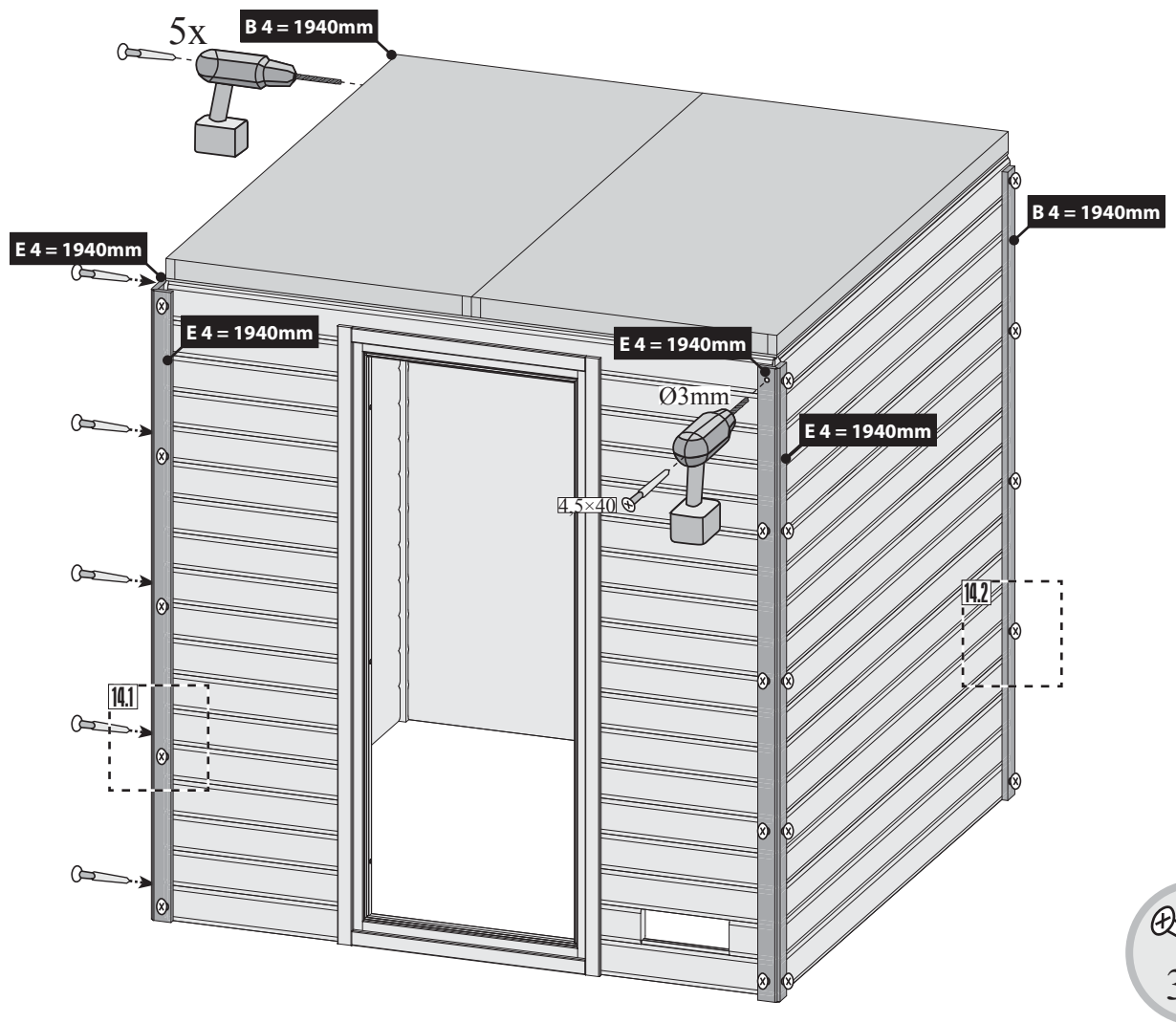

17.1

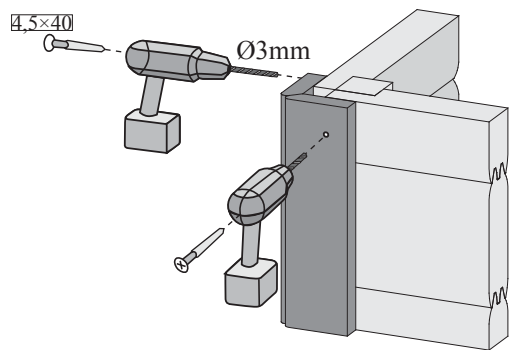



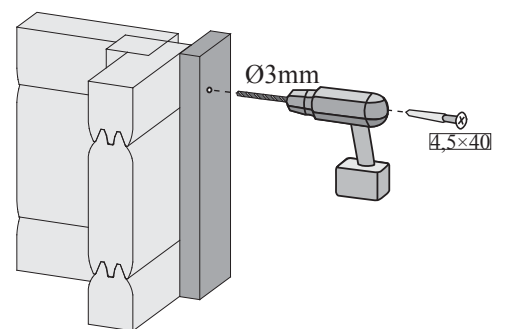

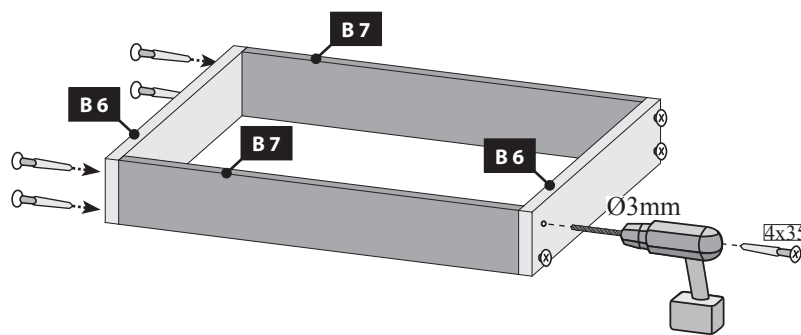
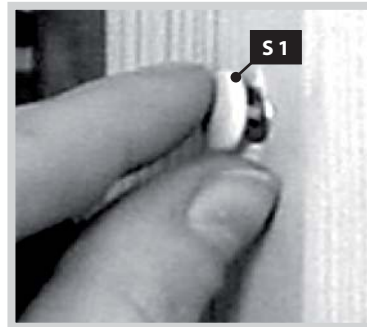
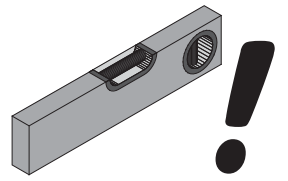
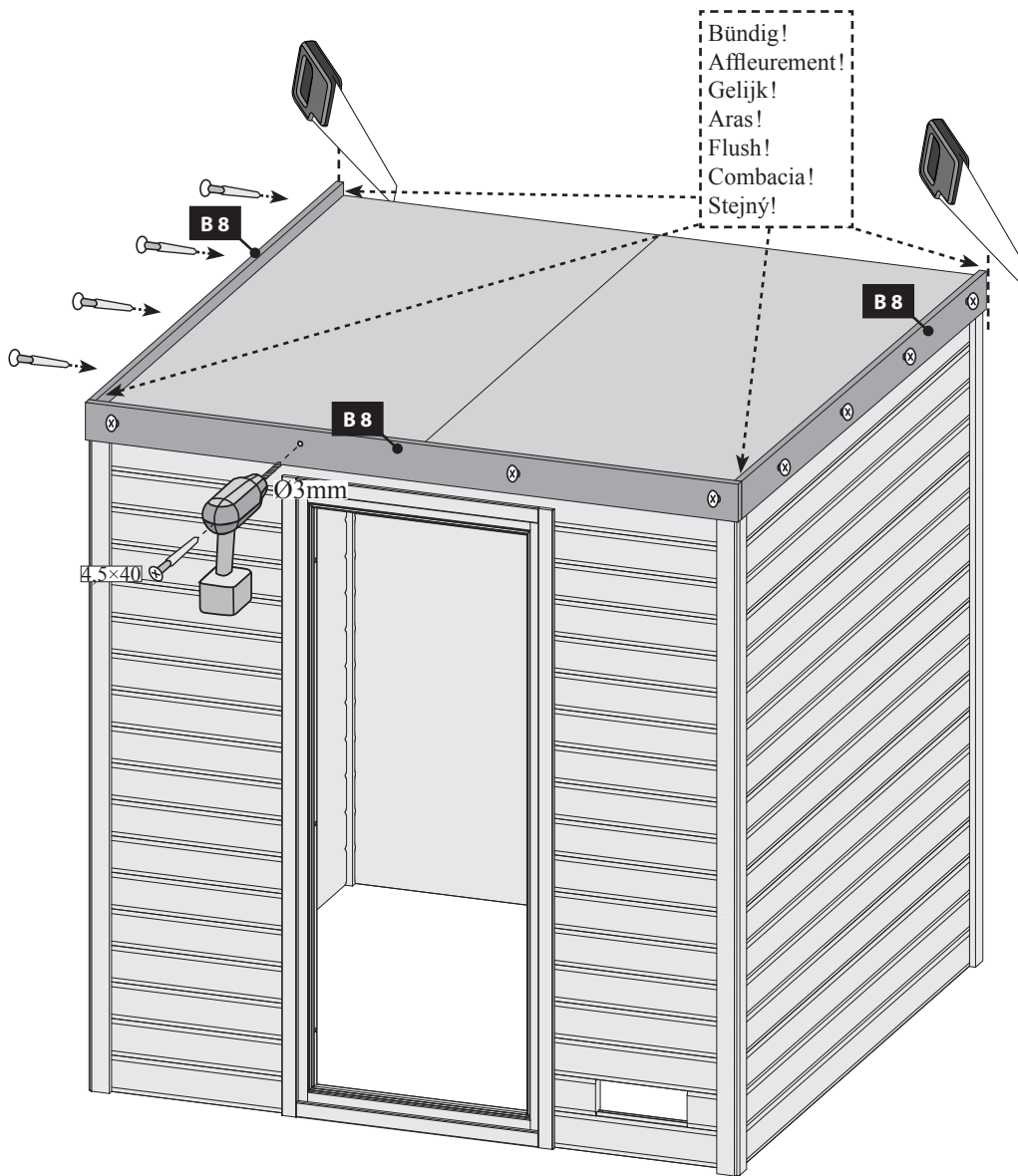

17.2





20 a

-  Nur bei 4,5 / 9 kW-Ofen
-  Seulement 4,5 / 9 kW chauffe
-  Only 4,5 / 9 kW heater
-  Slechts 4,5 / 9 kW heater
-  Sólo calentador de 4,5 / 9 kW
-  Solo riscaldamento 4,5 / 9 kW
-  Pouze topné těleso 4,5 / 9 kW

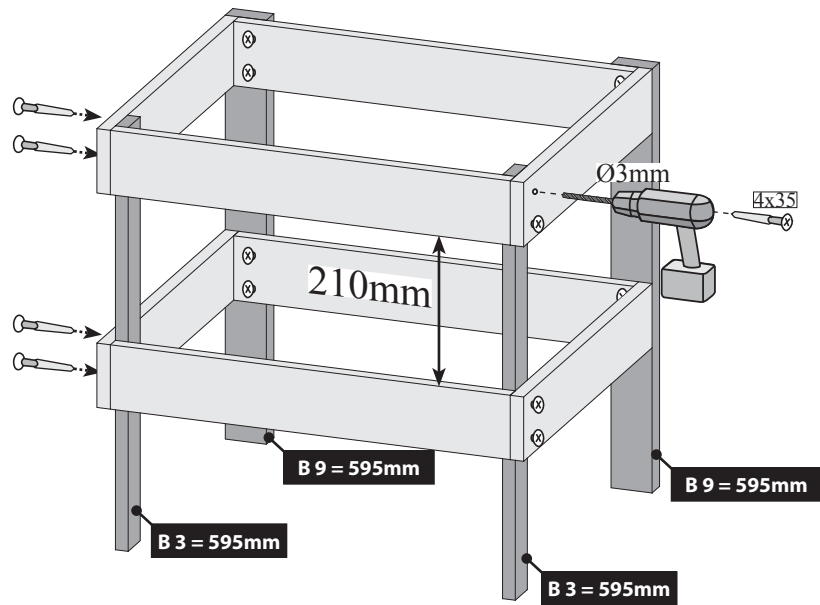
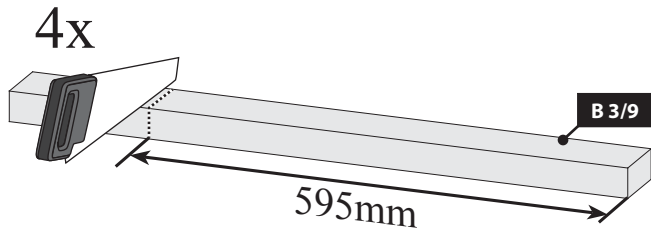

20 b

-  Bei allen anderen Öfen
-  Pour tous les autres fours
-  For all other furnaces
-  Voor alle andere ovens
-  Para todos los otros hornos
-  Per tutti gli altri tipi di forni
-  U všech ostatních pecích

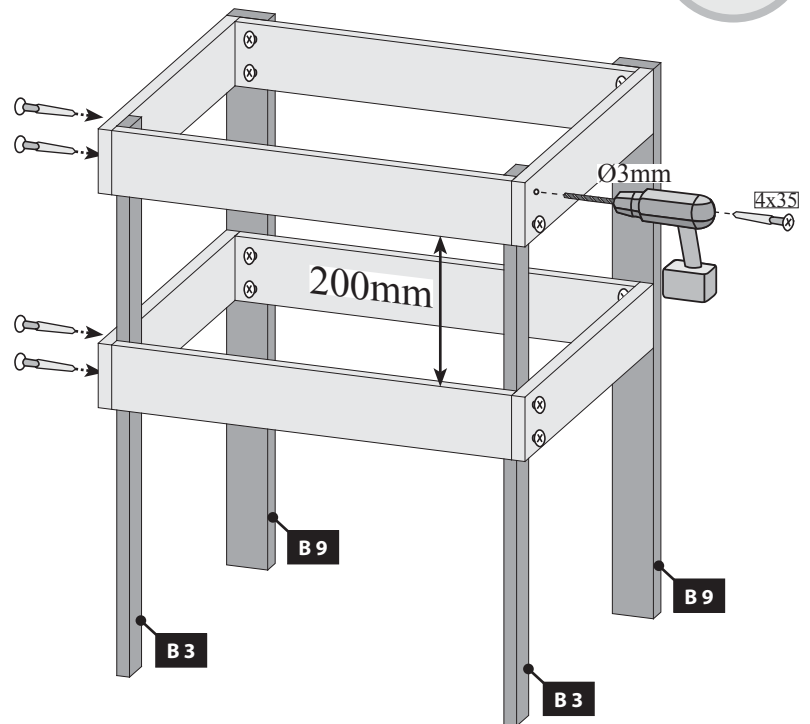

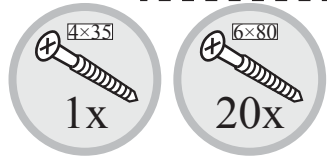
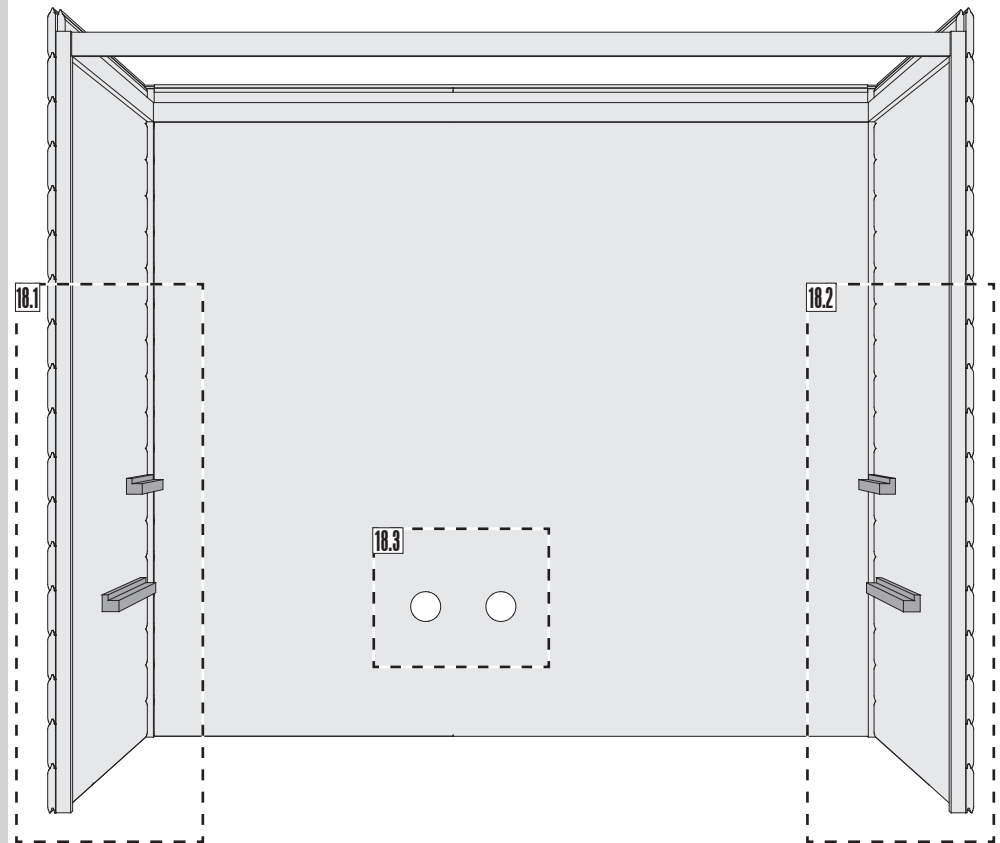

21.1-1

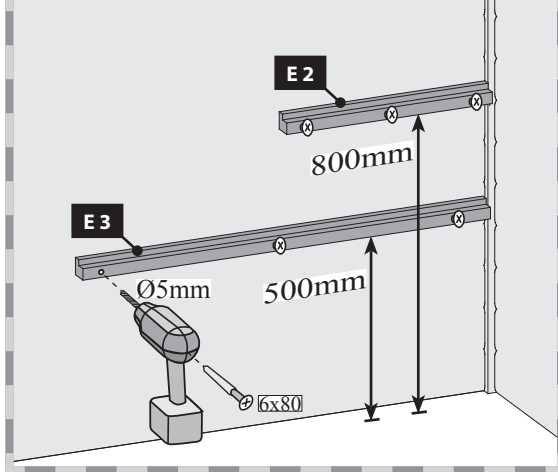

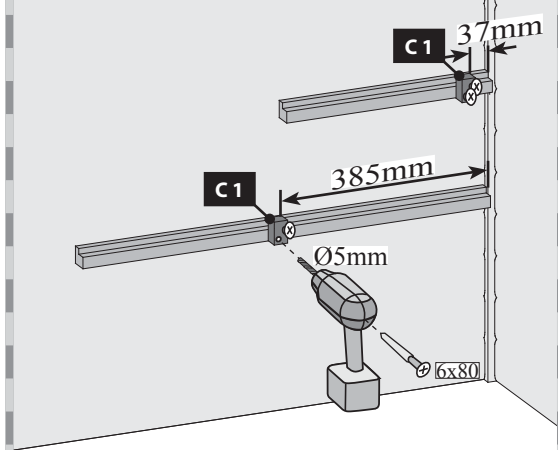

21.1-2



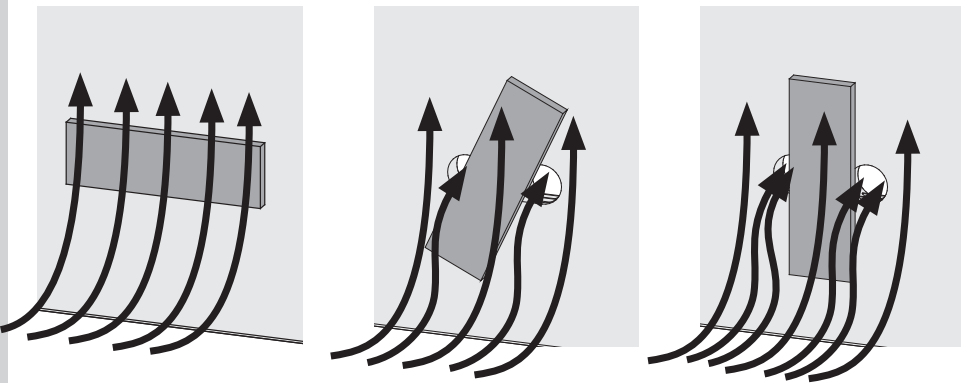
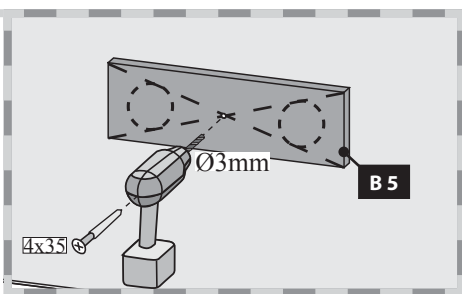

21.3





 Hier ist die Funktionsweise des Brettes abgebildet. Regeln Sie damit die Abluft nach Ihren eigenen Wünschen.

 Ceci représente le mode de fonctionnement de la planche. Avec elle, réglez l'écoulement de l'air selon vos désirs.

 This figure shows the functional principle of the board. Regulate the exhaust air according to your own wishes.

 Hier is de werking van het plankje afgebeeld. Regel daarmee de luchtafvoer naar eigen wens.

 Aquí está representada la forma de funcionamiento de la tabla. Regule con ello el aire de salida según sus propios deseos.

 Viene illustrato il principio di funzionamento della tavoletta di regolazione della ventilazione. Con essa si può regolare a piacere la ventilazione.

 Zde je zobrazená funkce desky. Regulujte s ní odsávací vzduch dle Vašeho přání.

21.2-1

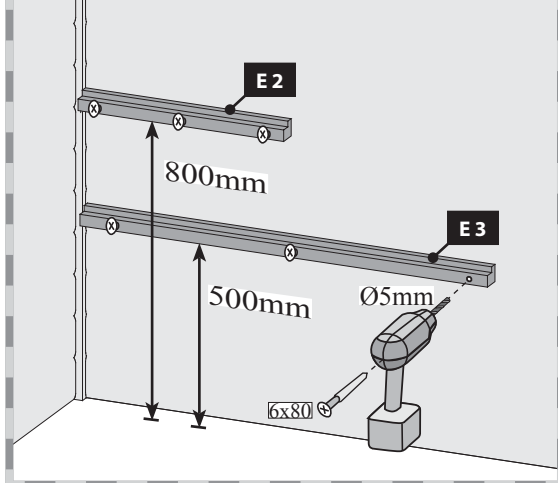

21.2-2

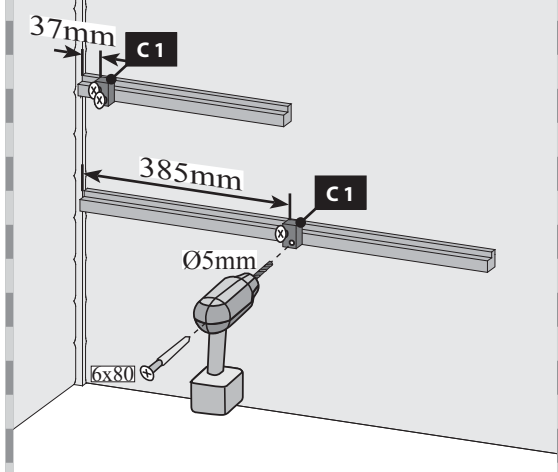

22 2x

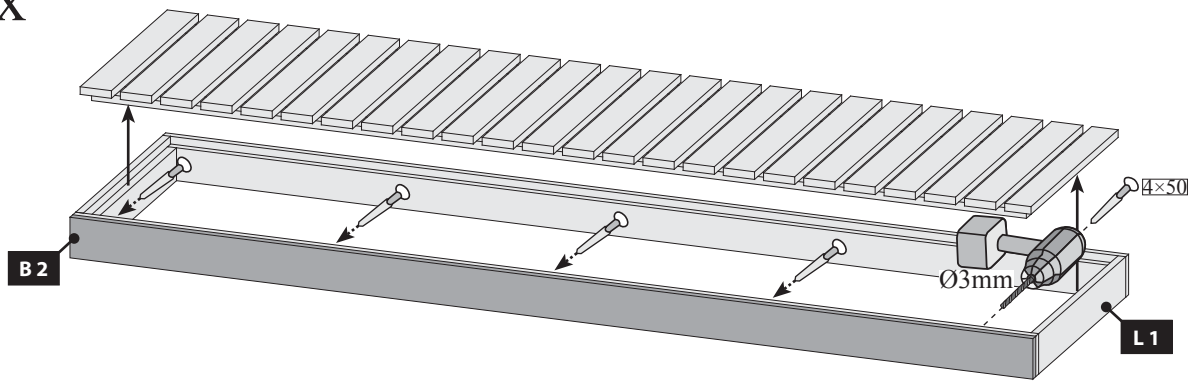

23

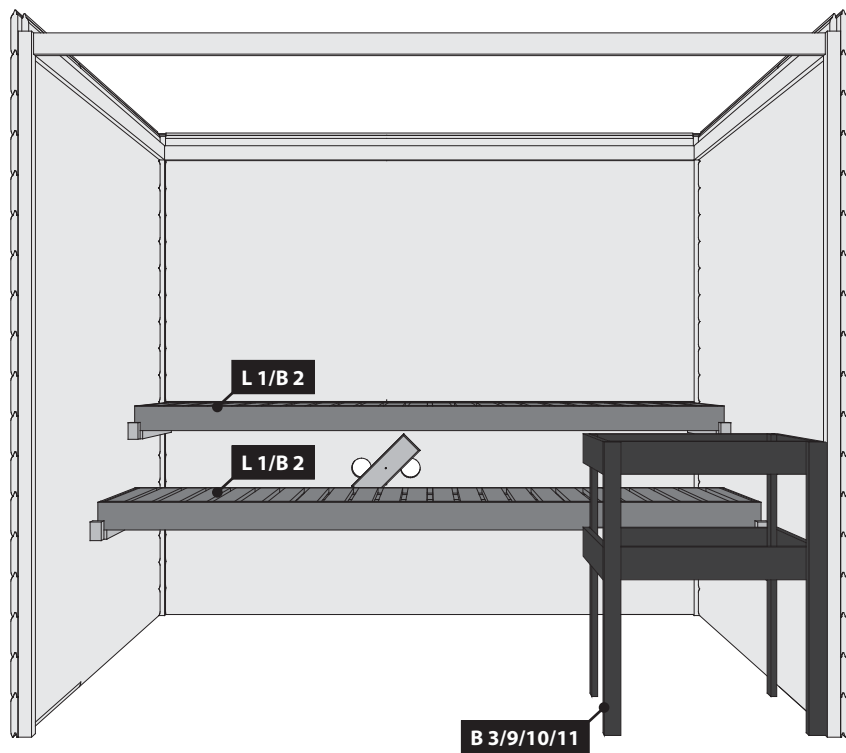

21

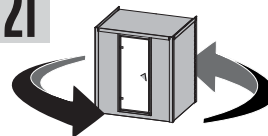

Bündig!
Affleurement!
Gelijk!
Aras!
Flush!
Combacia!
Stejný!

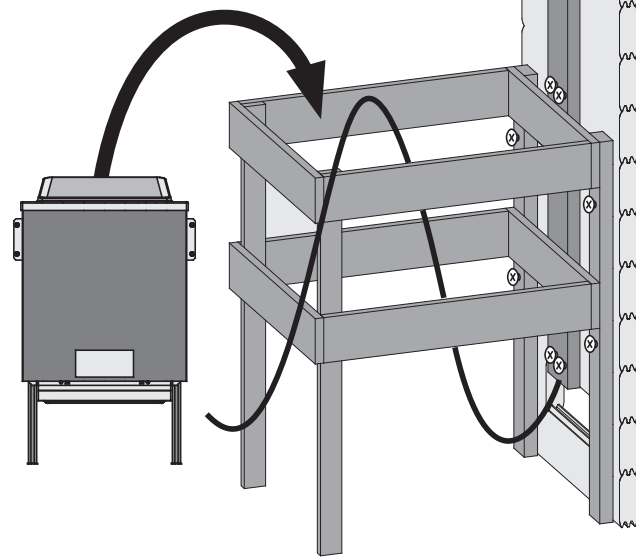
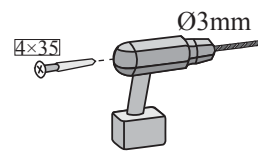
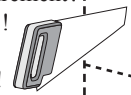

Saunatyp 38mm
Steuerung extern extern

