

**Technische Daten: Art.-Nr.: 535220**

**Wandaußenmaß: 580 x 280 cm**

**Bohlenstärke: 28 mm**



Dieses Haus wurde vom Kunden mit Imprägnierlasur Pinie/Kiefer farblich endbehandelt.

**Dieses Haus lässt sich auch spiegelverkehrt aufbauen.  
Darum ist es erforderlich, die Fußbodenbretter im Eingangsbereich  
laut beigefügter Zeichnung selbst zuzuschneiden.**

Kontrolliert durch:

Achtung: Alle angegebenen Maße sind ca.-Maße!

# 3D-Darstellung 535220

Das Haus lässt sich auch spiegeverkehrt aufbauen. Darum ist es erforderlich, die Fussbodenbretter im Eingangsbereich laut beigefügter Zeichnung selbst zuzuschneiden.

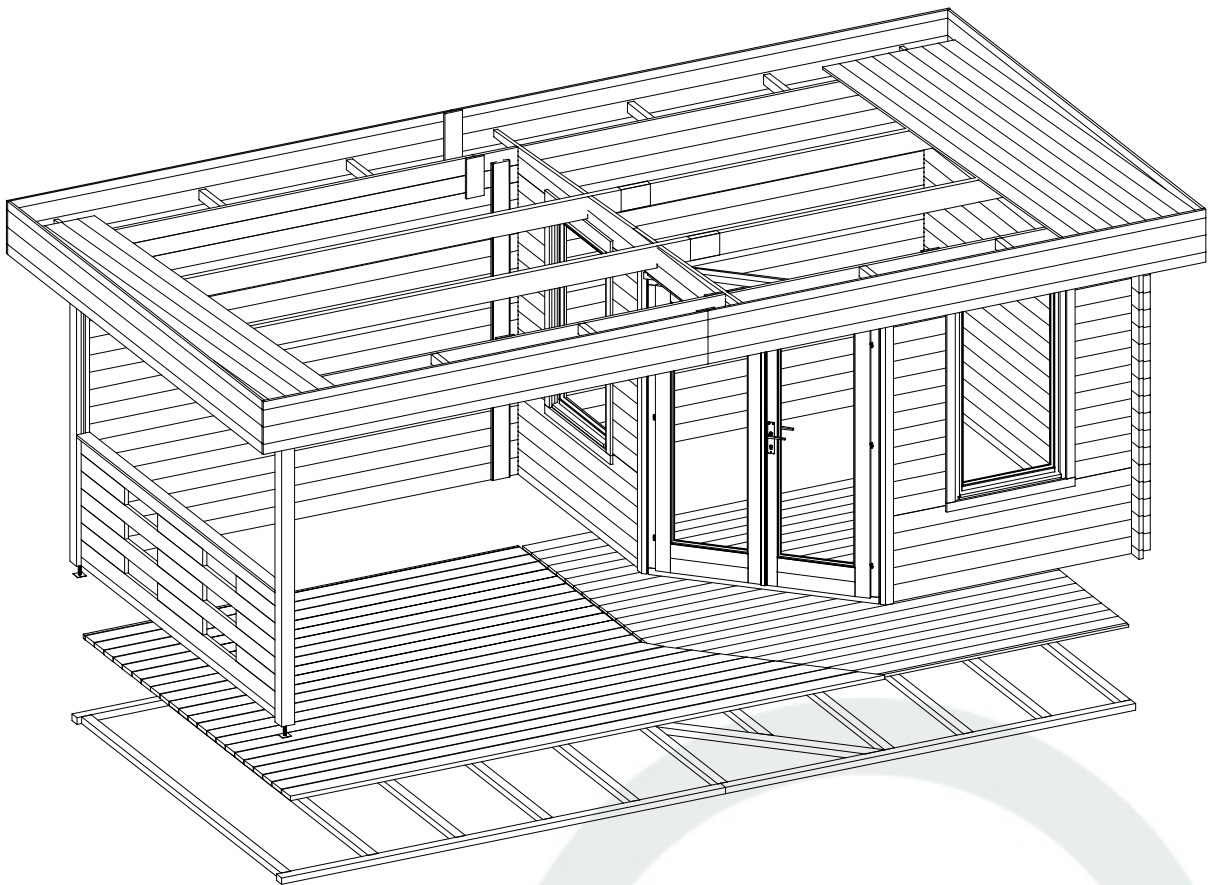

# Grundriss 535220

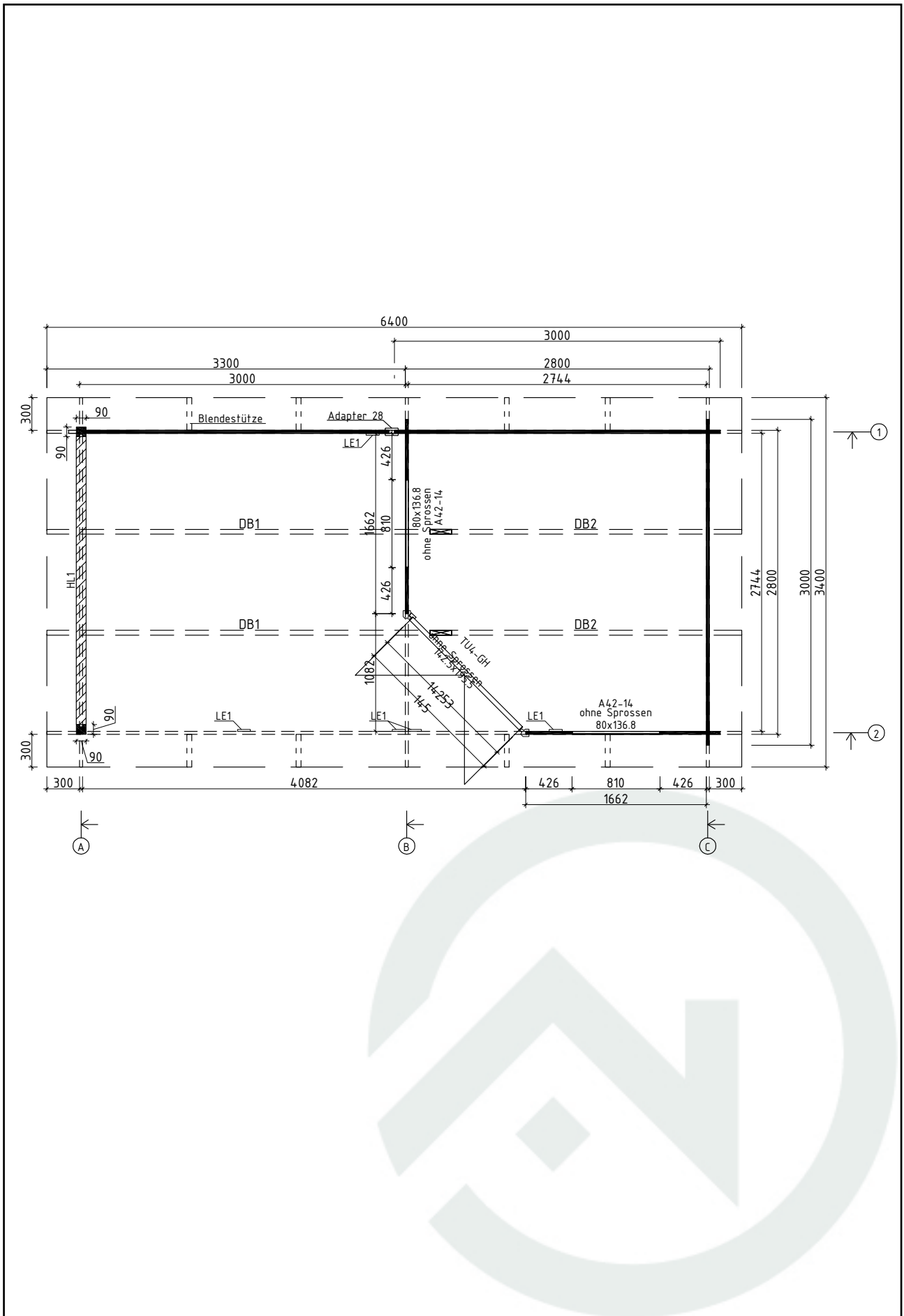





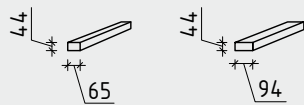
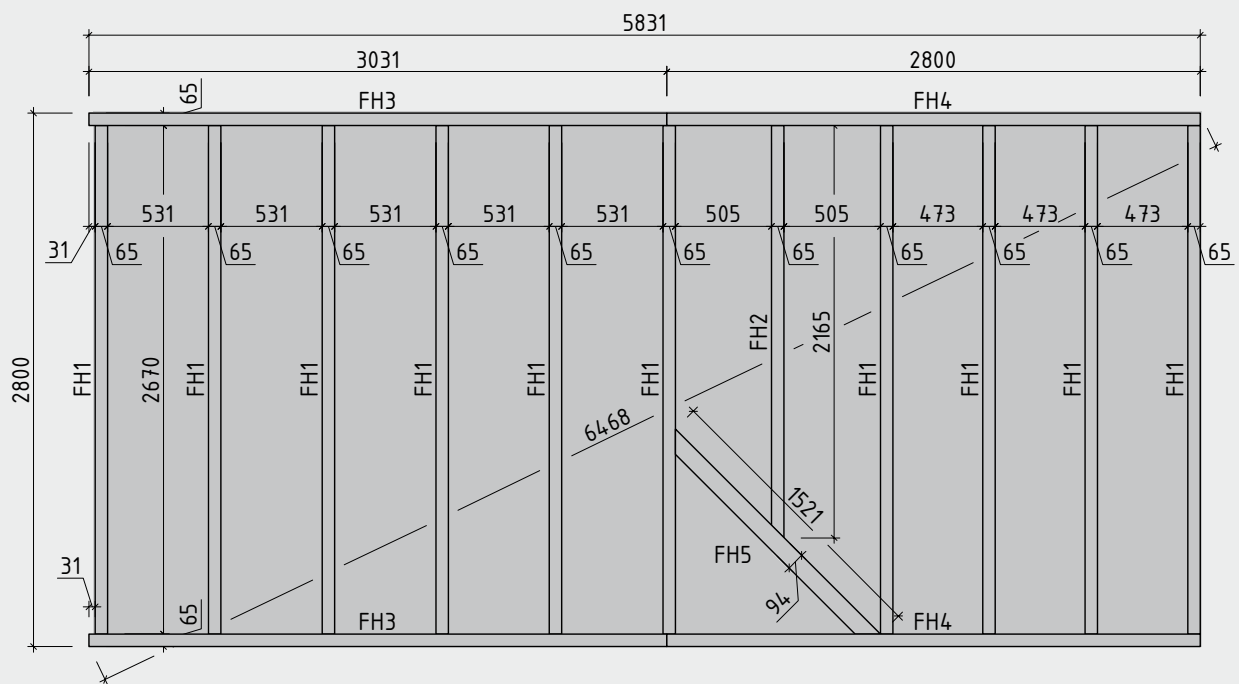

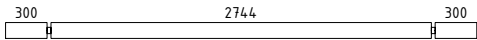
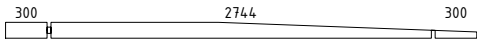
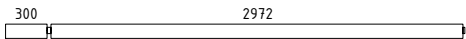
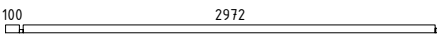
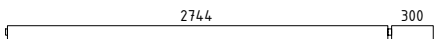
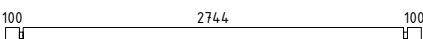
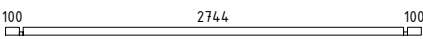
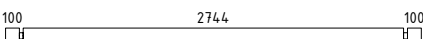
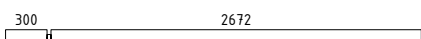
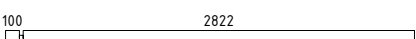
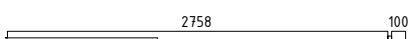

# Lagerholzplan und Fundamentplan 535220

Wir empfehlen als Fundament für Ihr Gartenhaus eine vollflächig festgegründete, gepflasterte oder betonierte Fläche.  
Wahlweise ist auch ein Punkt- oder Streifenfundament möglich.

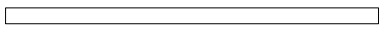
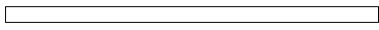

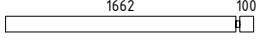
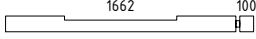
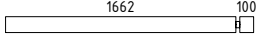
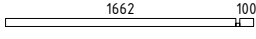
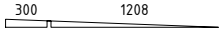
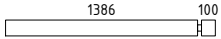







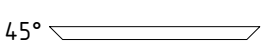

# Teileliste 1

## 535220

001		1	28x114	4486
002		1	28x114	3400
003		3	28x114	3400
004		1	28x103	3314
005		1	28x57	3114
006		1	28x103	3086
007		37	28x114	3000
008		1	28x57	3000
009		1	28x114	3000
010		1	28x114	3000
011		1	28x114	2950
012		1	28x114	2886
013		17	28x114	2811
014		1	28x114	2691
015		3	28x114	2691
016		1	28x57	2691
017		5	28x114	1790
018		1	28x114	1790
019		4	28x114	1790
020		1	28x57	1790
021		3	28x57	1536
022		1	28x114	1514
023		9	28x114	600
024		24	28x114	554
025		12	28x114	396
026		12	28x114	396

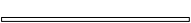
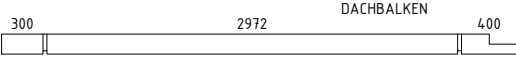
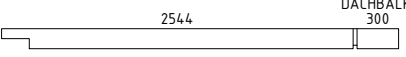

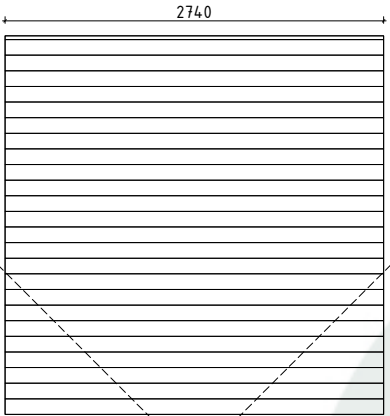

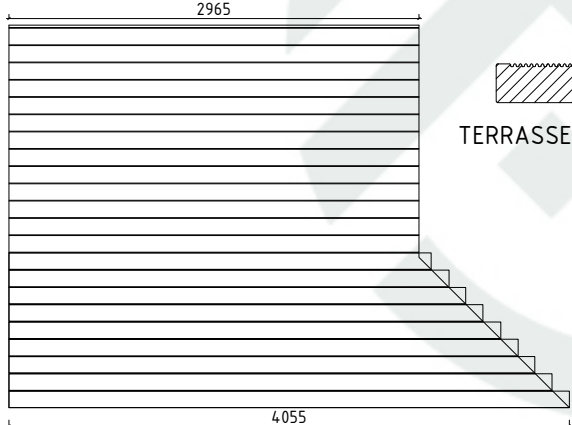
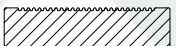







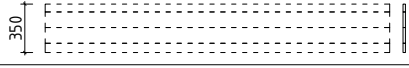
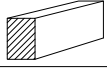

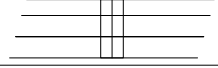

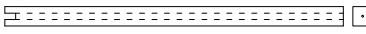

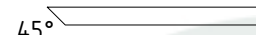

# Teileliste 2

## 535220

Pos		Stck	Profil (mm)	Länge (mm)												
FH5	 FUNDAMENTHÖLZER (imprägniert)	1	94x44	1521												
FH3	 FUNDAMENTHÖLZER (imprägniert)	2	65x44	3031												
FH4	 FUNDAMENTHÖLZER (imprägniert)	2	65x44	2800												
FH1	 FUNDAMENTHÖLZER (imprägniert)	10	65x44	2670												
FH2	 FUNDAMENTHÖLZER (imprägniert)	1	65x44	2165												
HL1	 HANDLAUF	✓ 1	90x18	2651												
LE1	 LEISTE	5	120x18	264												
LE2	 LEISTE	4	15x28	1358												
DB1	 DACHBALKEN	2	44x145	3728												
DB2	 DACHBALKEN	2	44x145	2872												
	DACHBRETTER 	57+1	113x18	3300												
<p>Diese Haus läßt sich auch spiegelvehrkert aufbauen. Darum ist es erforderlich, die Fussbodenbretter im Eingangsbereich laut beigefügter Zeichnung selbst zuzuschneiden.</p> <div style="display: flex; align-items: center;"> <div style="flex: 1;">  </div> <div style="flex: 1; text-align: center;">  <p>FUSSBODENBRETTER</p> </div> <div style="flex: 1; border-left: 1px solid black; border-right: 1px solid black; padding: 5px;"> <table style="width: 100%; border-collapse: collapse;"> <tr> <td style="text-align: center; width: 10%;">1</td> <td style="text-align: center; width: 20%;">113x18</td> <td style="text-align: center; width: 10%;">25+1</td> </tr> <tr> <td></td> <td style="text-align: center;">oder</td> <td style="text-align: center;">L-2740</td> </tr> <tr> <td style="text-align: center;">1</td> <td style="text-align: center;">88x18</td> <td style="text-align: center;">33+1</td> </tr> </table> </div> </div>		1	113x18	25+1		oder	L-2740	1	88x18	33+1						
1	113x18	25+1														
	oder	L-2740														
1	88x18	33+1														
<p>Diese Haus läßt sich auch spiegelvehrkert aufbauen. Darum ist es erforderlich, die Terrassenbretter im Eingangsbereich laut beigefügter Zeichnung selbst zuzuschneiden.</p> <div style="display: flex; align-items: center;"> <div style="flex: 1;">  </div> <div style="flex: 1; text-align: center;">  <p>TERRASSENBRETTER</p> </div> <div style="flex: 1; border-left: 1px solid black; border-right: 1px solid black; padding: 5px;"> <table style="width: 100%; border-collapse: collapse;"> <tr> <td style="text-align: center; width: 10%;">1</td> <td style="text-align: center; width: 20%;">120x28</td> <td style="text-align: center; width: 10%;">14+1</td> </tr> <tr> <td></td> <td></td> <td style="text-align: center;">L-2965</td> </tr> <tr> <td></td> <td></td> <td style="text-align: center;">9</td> </tr> <tr> <td></td> <td></td> <td style="text-align: center;">L-3055-4055</td> </tr> </table> </div> </div>		1	120x28	14+1			L-2965			9			L-3055-4055			
1	120x28	14+1														
		L-2965														
		9														
		L-3055-4055														

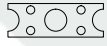
# Teileliste 3

## 535220

Pos			Stck	Profil (mm)	Länge (mm)
	FUSSBODENLEISTE		✓	18x40	11,0 lfm
A28-1	ADAPTER 120x66	Obere seite 	✓	120x66	2110
BL-1	DACHBLENDEN 350mm		4	18x350	3218
BL-2	DACHBLENDEN 350mm		2	18x350	3400
BS-1	DACHBLENDEN- Blendenstützen 44x65		8	44x65	300
UPB-1	DACHBLENDEN- U-Profil für Blenden		✓	65x44	20,0 lfm
VL-1	DACHBLENDEN- Verbindungsleisten 350mm		2	120x18	350
DPL-1	DACHPAPPENLEISTE 15x28		✓	15x28	13,0 lfm
T4-1	TRAUFENLEISTE 40x18		✓	40x18	13,0 lfm
SP2-1	STÜTZPFOSTEN 90x90	! 	✓	90x90	1995
SP2-2	STÜTZPFOSTEN 90x90	! 	✓	90x90	1995
SM-1	Sturmleisten		2	40x18	2085
SM-2	Sturmleisten		2	40x18	2200
DzT 40-1	ECKTÜR- Deckbrett zum Tür 40		1	18x40	1585
VK1-1	ECKTÜR- Verkleidungsleisten für Vordachelement	45° 	✓	58x12	1110
P7L-1	ECKTÜR- linke Türpfoste	40 	1	67x77	2015
P7R-1	ECKTÜR- rechte Türpfoste	40 	1	67x77	2015
VE1	ECKTÜR- Vordachelement 1435x745		1		
SH	Schlaghölzer		3		
SS01	Schlossschrauben M8x60 Mutter U-Scheibe		12	M8	
VS	VERBINDUNGSTREIFEN für verbinden der Wandbohlen		2		
VP2	Verstellbare Pfostenstütze M16		2	M16	
NG3	DACHPAPPNÄGEL 2.0x18		510		
NG1	NÄGEL 2.5x50	Dachbretter Fussbodenbretter		756	
NG2	NÄGEL 2.5x60	Terrassenbretter		299	

# Teileliste 4

## 535220

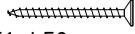
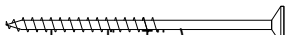
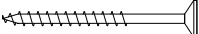
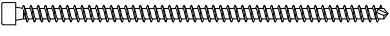
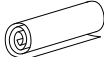
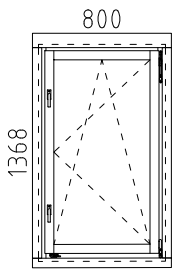
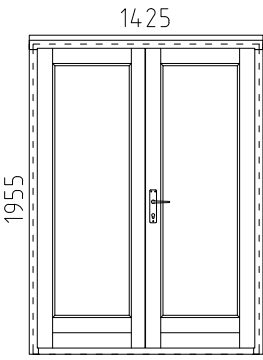
Pos		Stck	Profil (mm)	Länge (mm)
SR01	SCHRAUBEN 3.0x30 Dachpappenleisten, Fussbodenleisten Traufenleisten 40x18, Verbindungsleisten VL-1 	82		
SR03	SCHRAUBEN 3.5x45 U-Profil, Verbindungstreifen VS, Deckbrett DzT40-1, Vordachelement VE1, LE1, LE2 Verkleidungsleisten VK-1, HL1 	150		
SR11	SCHRAUBEN 5.0x100 Fundamenthölzer pos 017 und 020 (1. Bohlenreihe neben die Tür) 	68		
SR10	SCHRAUBEN 5.0x70 Blendenbefestigung Blendestützen 	70		
SR21	SCHRAUBEN 6.0x140 (ASSY für Dachbalken) 	4		
	DACHPAPPE 	✓	7,1m-4st.	29,0 lfm
	FENSTER 800x1368  A42-14 DIN 1xrechts/1xlinks	2		
	TÜR 1425x1955  TU4-GH DIN rechts	1		
	✓ - bitte selber anpassen (falls nötig)!			



# Fußbodenbretter / Terrassenbretter 535220

## Fußbodenbretter 113x18

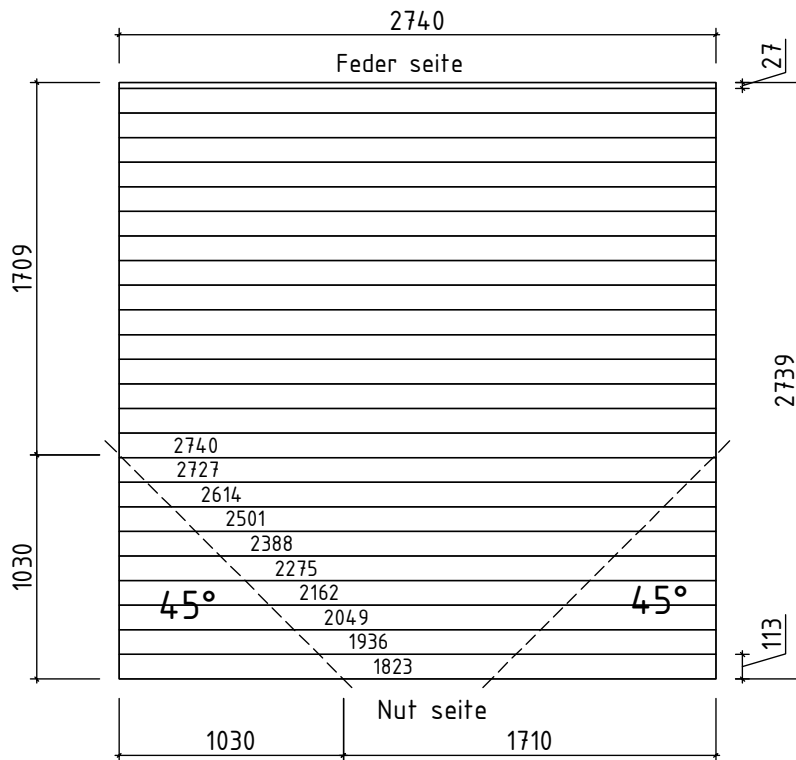

## Terrassenbretter 120x28



# Wandplan 1 und 2 535220

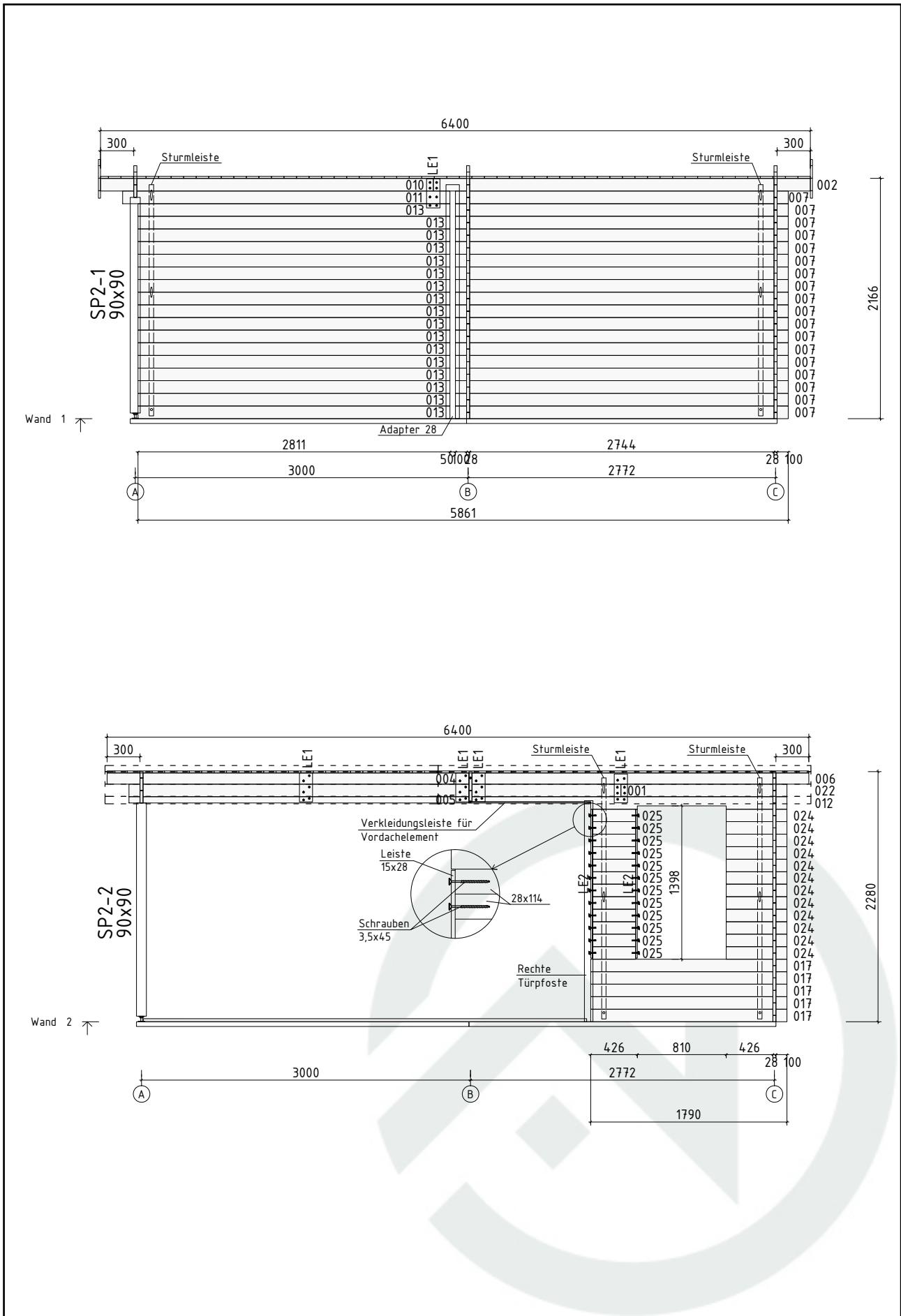

# Wandplan A

## 535220

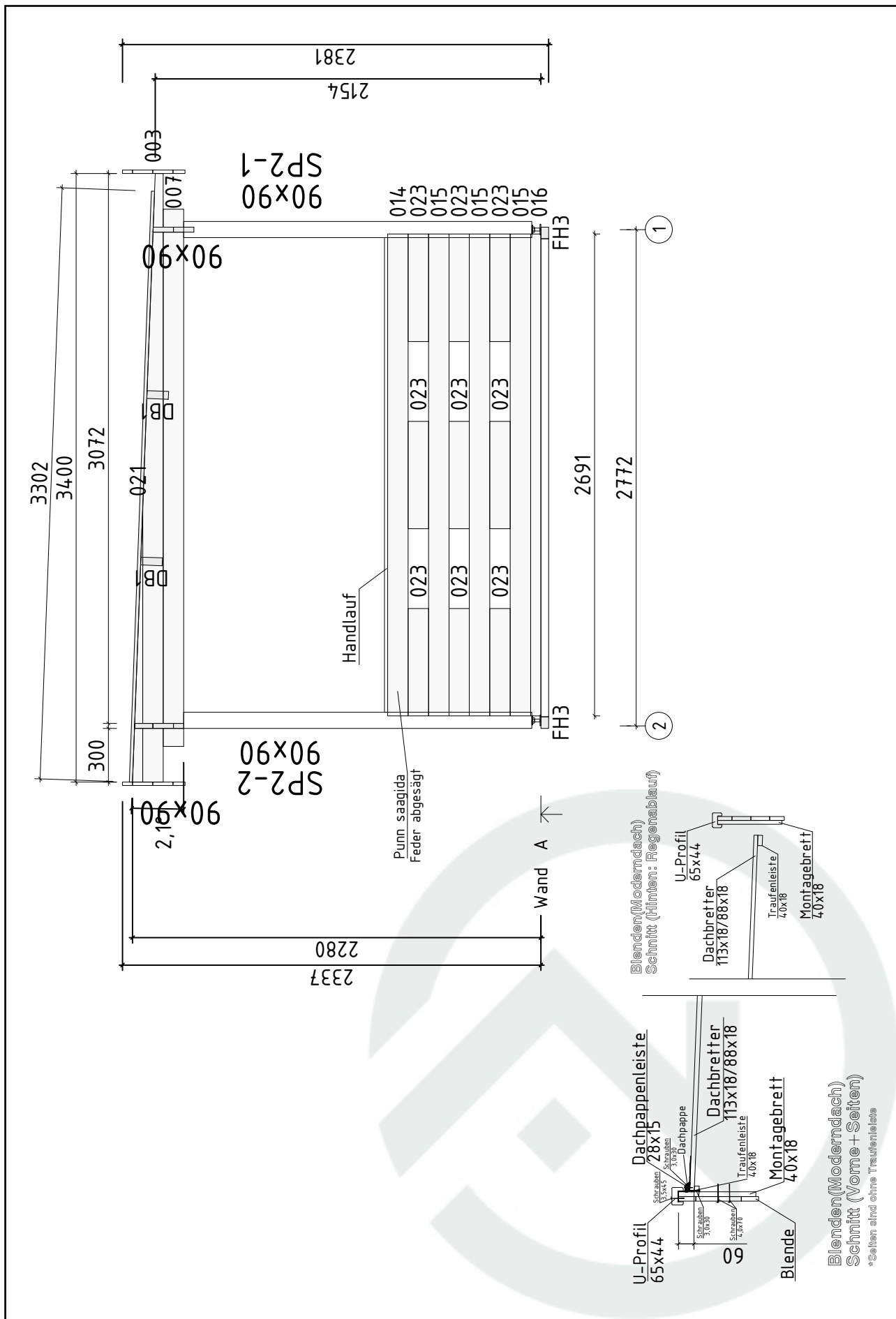

# Wandplan B und C

## 535220

