

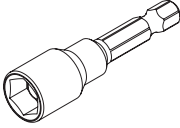
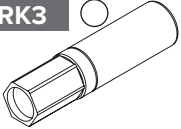
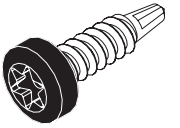
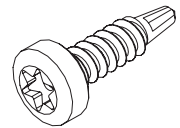
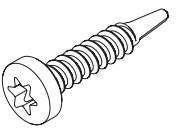
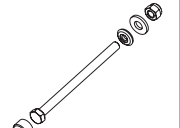
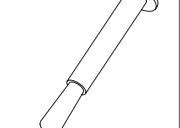
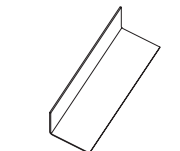
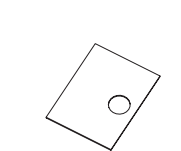
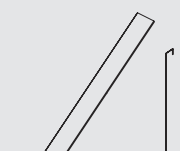
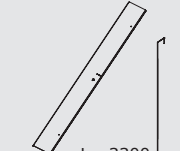
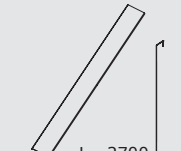
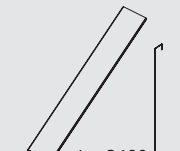
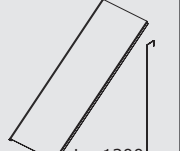
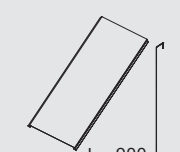
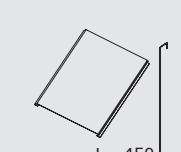
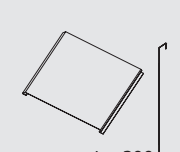
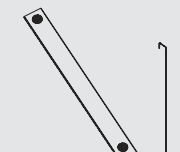
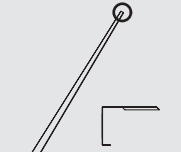
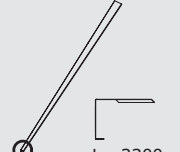

Liste des composants / Stukslijst / Partslist / Teileliste

<b>TOOL4</b> 1x 	<b>RK1</b> ● 1x <b>RK2</b> ● <b>RK3</b> ○ 	<b>SD18BL</b> 80x 	<b>SD18</b> 900x 	<b>SD25</b> 2x 	<b>M8x120</b> 4x 	<b>M12x115</b> 8x 
<b>KG-Hoek</b> 2x 	<b>RT0,9</b> 8x 	<b>DI33</b> 6x  L= 3300	<b>DI33G</b> 1x  L= 3300	<b>DI27</b> 12x  L= 2700	<b>DI24</b> 8x  L= 2400	<b>DI12</b> 6x  L= 1200
<b>DI09</b> 4x  L= 900	<b>DI04</b> 12x  L= 450	<b>DI03</b> 6x  L= 300	<b>DI33VL</b> 1x 	<b>XGA</b> 1x  L= 3300	<b>XGC</b> 1x  L= 3300	<b>XGBDH</b> 2x  L= 2550
<b>XGBDL</b> 2x  L= 2550	<b>MVA</b> 2x ● 	<b>MVB</b> 2x ● 	<b>IGaL</b> 2x  L= 2.090mm	<b>IGaK</b> 2x  L= 2.070mm		

**Fundament**

- Le sol doit être **plat et de niveau**. Le sol doit être réalisé pour permettre une fixation adéquate de l'abris de jardin.
- De vloer moet **vlak en waterpas** zijn. De vloer moet gemaakt worden zodat de bevestiging van het tuinhuis wel mogelijk is.
- The floor must be **flat and level**. The floor must be made in such a way that it is possible to fix the garden house.
- Der Aufbauort muss eine **flache, geschlossene und in Waage liegende Bodenplatte** aufzeigen. Die Bodenplatte muss so beschaffen sein, das eine mechanische Befestigung von dem Eleganto erfolgen kann.

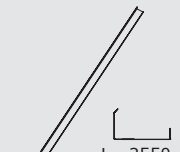
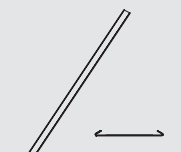
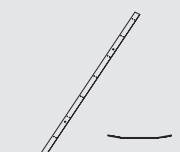
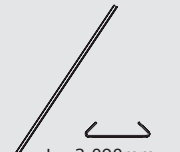
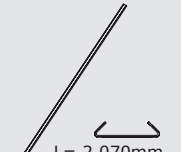
**PS**

- L'abris de jardin doit être centrée sur la dalle de béton.
- Het tuinhuis moet gecentreerd geplaatst worden op het fundament.
- The garden house must be centered on the foundation.
- Das Gartenhaus muss auf dem Fundament zentriert sein.

