

DUO 3336

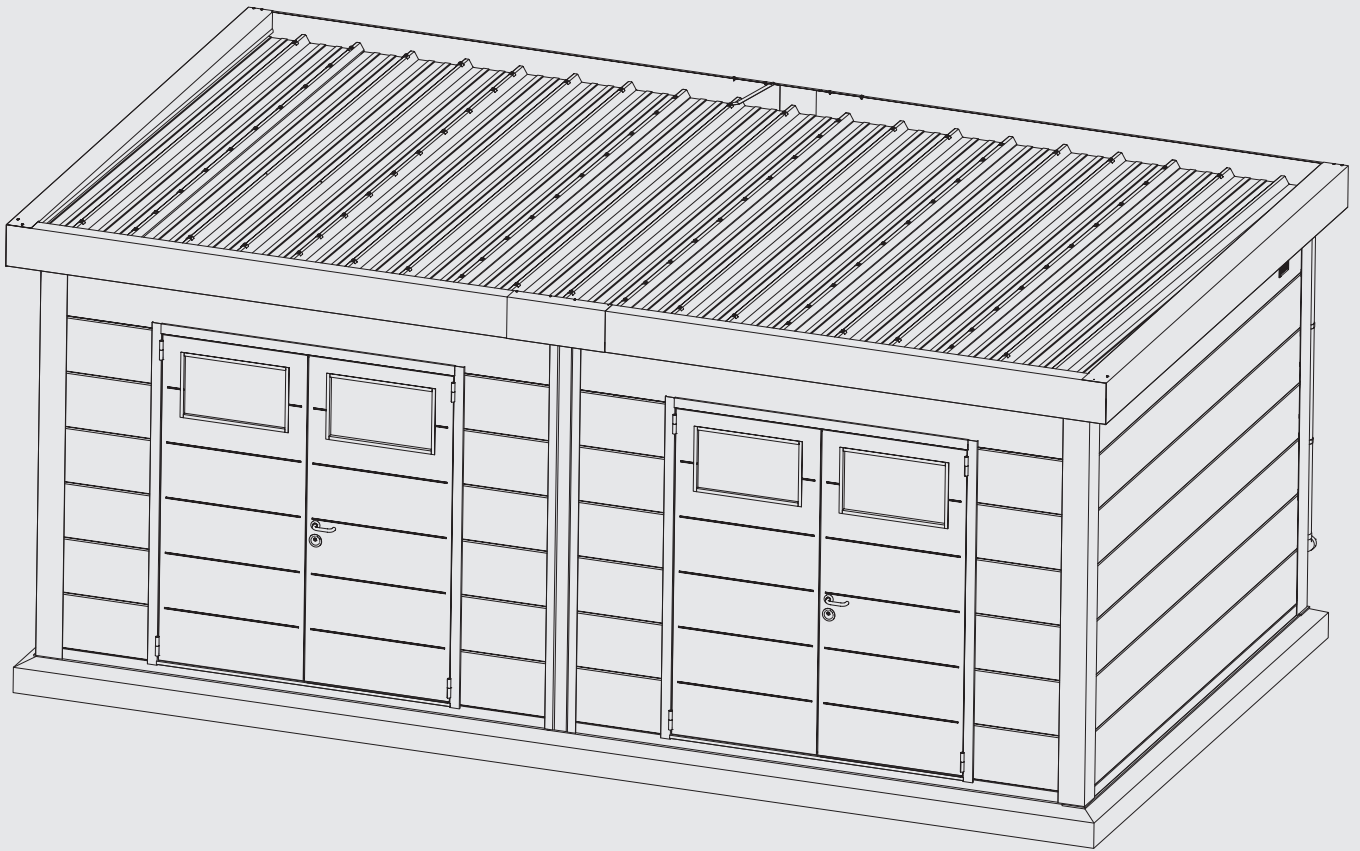

INSTRUCTIONS DE MONTAGE
MONTAGE HANDLEIDING
ASSEMBLY INSTRUCTIONS
MONTAGEANLEITUNG

Projet numéro / Project nummer / Project number / Projekt Nummer :

.....

QC-numéro / QC-nummer / QC-number / QC-Nummer :

.....

Couleur / Kleur / Colour / Farbe:

Blanc, Wit, White, Weiß

Gris clair, Licht grijs, Light grey, Lichtgrau

Anthracite, Antraciet, Anthracite, Granitgrau

telluria

LET US STEEL YOUR HEART

Nous vous invitons à lire attentivement le présent mode d'emploi. Vous y trouverez les caractéristiques techniques ainsi que toutes les informations utiles en vue d'un fonctionnement correct. Les données techniques figurant dans cette publication peuvent être modifiées à tout moment et sans avis préalable et ce, pour des raisons techniques ou commerciales..

Wij nodigen u uit deze handleiding aandachtig te lezen. Ze omvat de technische eigenschappen en alle nuttige informatie voor een correcte werking. De technische gegevens in deze publicatie kunnen om technische of commerciële redenen op elk moment en zonder voorafgaande kennisgeving worden gewijzigd.

Please read this manual carefully. It contains the technical properties and all the information required for correct operation. The technical data in this publication is subject to change for technical and/or commercial reasons at any time and without notice.

Bitte lesen Sie diese Anleitung sorgfältig durch. Sie enthält die technischen Eigenschaften und alle Informationen, die für einen korrekten Betrieb erforderlich sind. Die in dieser Publikation enthaltenen technischen Daten können jederzeit ohne Vorankündigung aus technischen oder kommerziellen Gründen geändert werden.

Lisez bien l'ensemble du mode d'emploi avant de commencer à réaliser des travaux.	L'utilisation de gants est obligatoire.	L'utilisation de lunettes de protection est obligatoire.	L'utilisation d'un casque de protection est obligatoire.	L'utilisation d'une meule est interdite	Déballage à 2 personnes	Retirer les éclats de métal.
Lees de volledige handleiding voordat u begint met de werken uit te voeren.	Het gebruik van handschoenen is verplicht.	Het gebruik van een veiligheidsbril is verplicht.	Het gebruik van een veiligheidshelm is verplicht.	Het gebruik van een slijpschijf is verboden	Met 2 personen uitpakken	Metaalsplinters verwijderen
Read the entire manual before you start working.	The use of gloves is mandatory.	The use of safety glasses is mandatory.	The use of a hard hat is mandatory.	The use of an angle grinder is prohibited	Unpack with 2 people	Cleaning up metal splinters
Lesen Sie vor Arbeitsbeginn die gesamte Anleitung.	Das Tragen von Handschuhen ist Pflicht.	Das Tragen einer Sicherheitsbrille ist Pflicht.	Das Tragen eines Sicherheitshelms ist Pflicht.	Die Verwendung einer Schleifscheibe ist verboten	Auspacken mit 2 Personen	Metallsplinter entfernen

Liste d'outils / Gereedschappenlijst / Tools List / Werkzeugliste

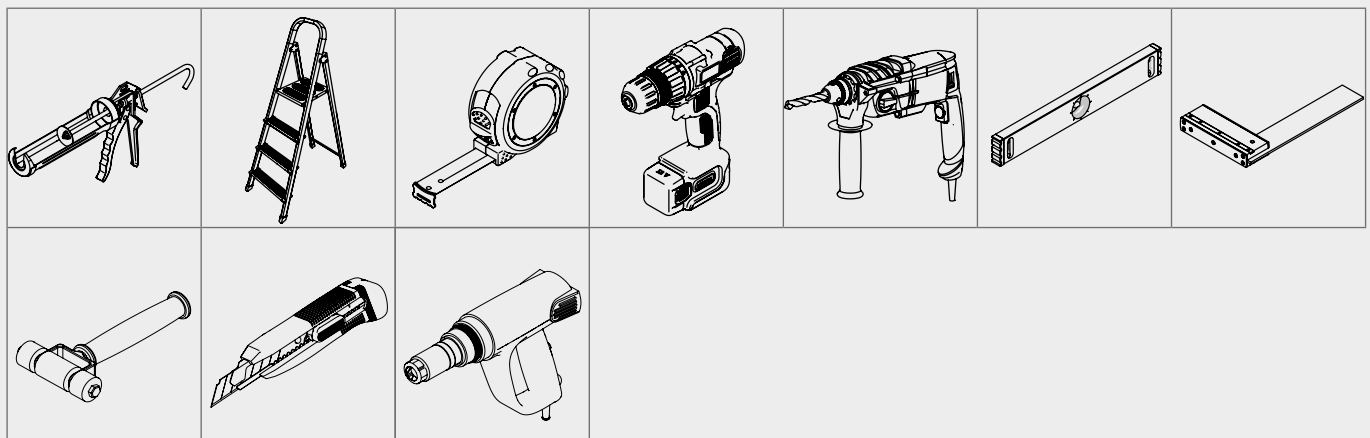

Liste des composants / Stukslijst / Partslist / Teileliste

Pour la liste actuelle des pièces, voir pièce jointe.

Voor de actuele stuklijst zie bijlage.

For the current parts list see attachment.

Aktuelle Stückliste siehe Anhang.

Eleganto Lounge Small / 3024 / Anthracite / Right						
EP.GRT.ANT.3024PHR						21569.1
KIST.04 x1 	S.3024PHR x1 	BE x33 	FE x10 	SSP x1 	WP45 x1 	SDPH x2
FD18 x1 	FPN2 x2 	FPN1 x1 	JDA27 x2 	JZ7 x2 	JDA27 x1 	JZ7R x1
JZ1 x3 	JZ1S x3 	W2 x1 	UD18 x1 	SDA21 x9 	SDA21 x11 	SDA21V x1
SDA45 x6 	S.ZAV-ZCVR x1 	HPH x1 	HA4 x4 	S.ZZ18D x1 	S.ZZ18A x1 	S.ZZ18C x1
SPH4 x1 	SPH2 x2 	SPH1 x1 	SPH3 x1 	SPH4 x1 	SPH4 x1 	SPH4 x1
S.ZPH4 x1 	A21 x3 	A27 x1 	A27 x2 	M21 x3 	M27 x3 	D.85 x1
S.AP x1 	SE x2 	END x1 	MBL1 x1 			

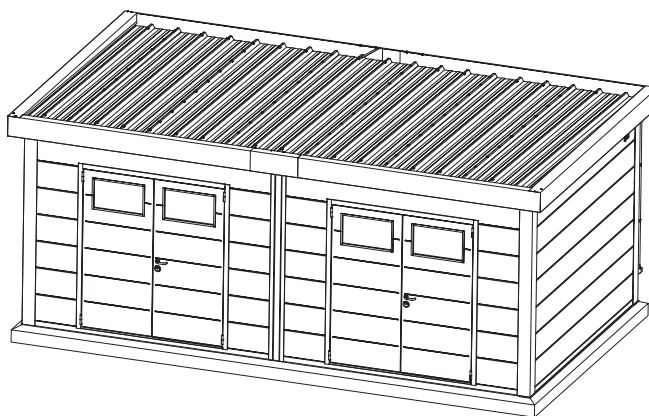
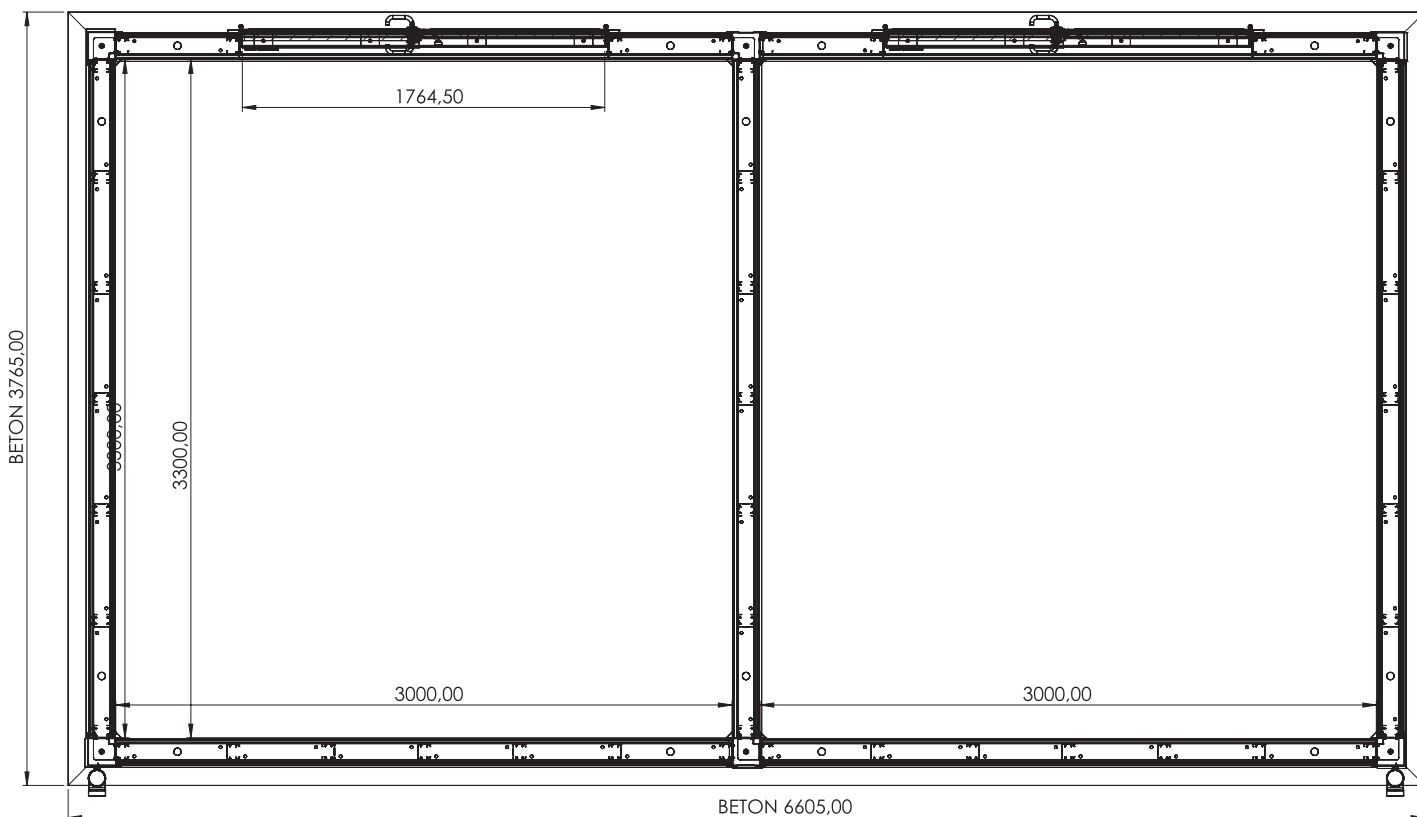

Fundament

- Le sol doit être **plat et de niveau**. Le sol doit être réalisé pour permettre une fixation adéquate de l'abris de jardin.
- De vloer moet **vlak en waterpas** zijn. De vloer moet gemaakt worden zodat de bevestiging van het tuinhuis wel mogelijk is.
- The floor must be **flat and level**. The floor must be made in such a way that it is possible to fix the garden house.
- Der Aufbauort muss eine **flache, geschlossene und in Waage liegende Bodenplatte** aufzeigen. Die Bodenplatte muss so beschaffen sein, das eine mechanische Befestigung von dem Eleganto erfolgen kann.

PS

- L'abris de jardin doit être centrée sur la dalle de béton.
- Het tuinhuis moet gecentreerd geplaatst worden op het fundament.
- The garden house must be centered on the foundation.
- Das Gartenhaus muss auf dem Fundament zentriert sein.

Composition / Compositie / Composition / Zusammensetzung

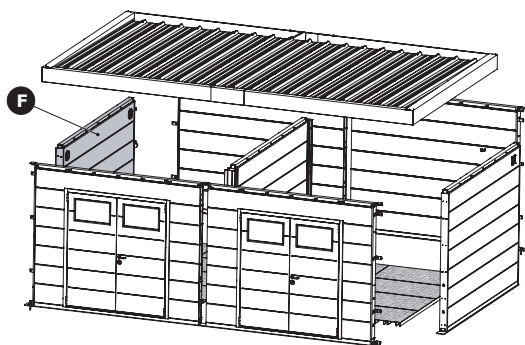
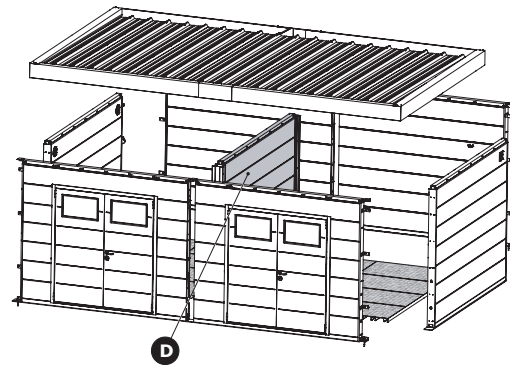
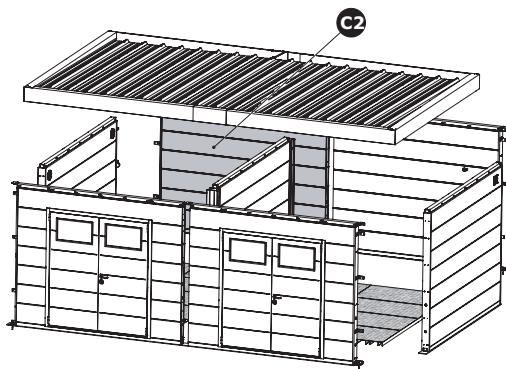
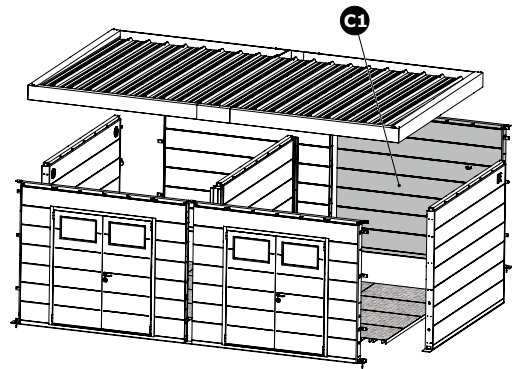
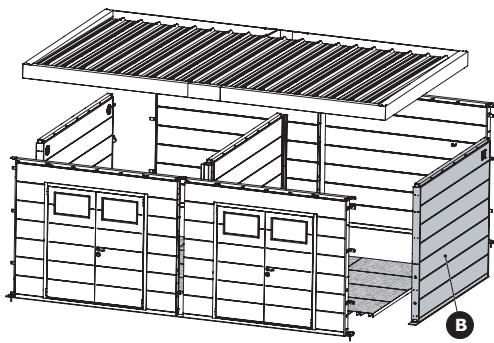
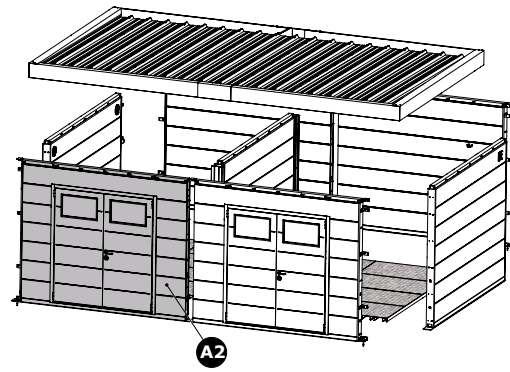
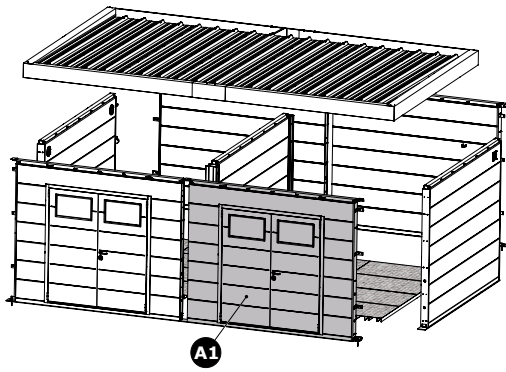

3X = B/D/F

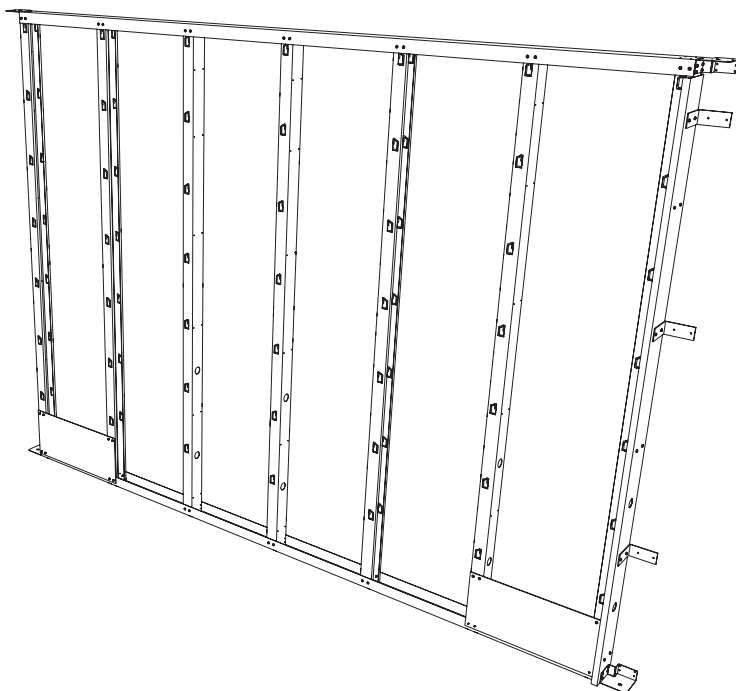

B/D/F Paroi / Wand / Wall / Wand

3X

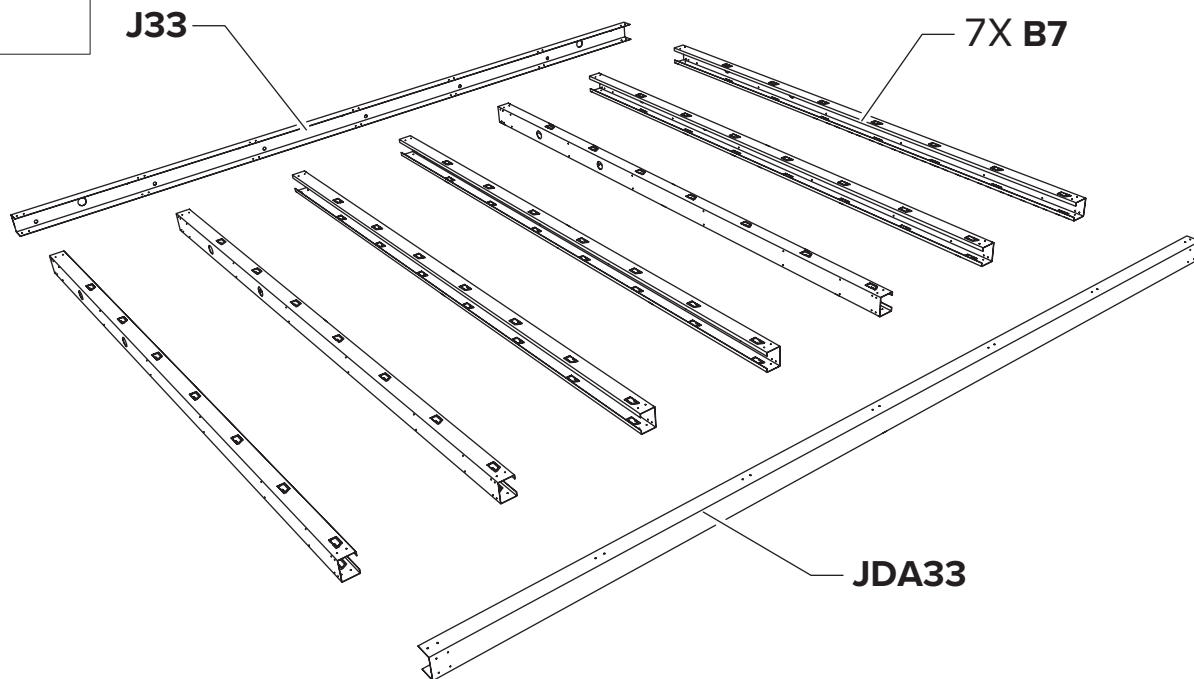

B/D/F Paroi / Wand / Wall / Wand

POW

Le principe de la construction du mur (POW).
 Het principe van de opbouw van de wand (POW).
 The principle of building the wall (POW).
 Das Prinzip des Baus der Mauer finden (POW).

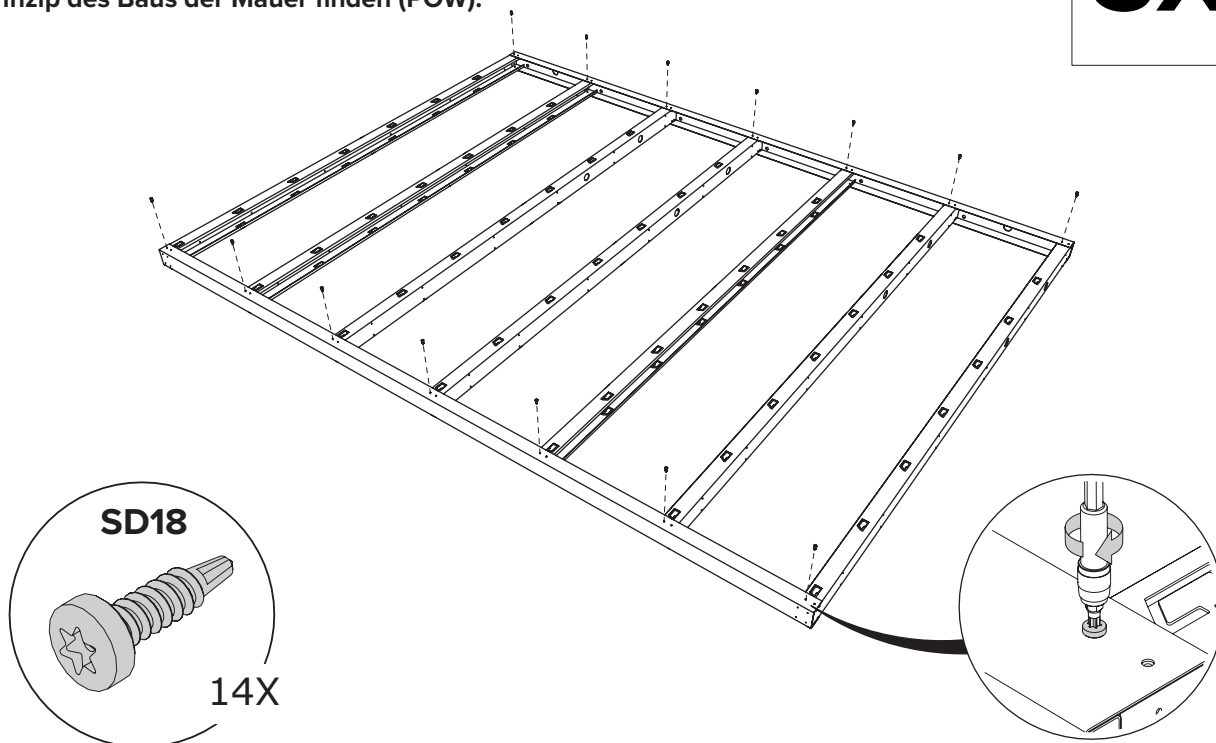
3X

B/D/F Paroi / Wand / Wall / Wand

POW

Tourner encadrement / Kader omdraaien / Turn Frame / Rahmen umdrehen

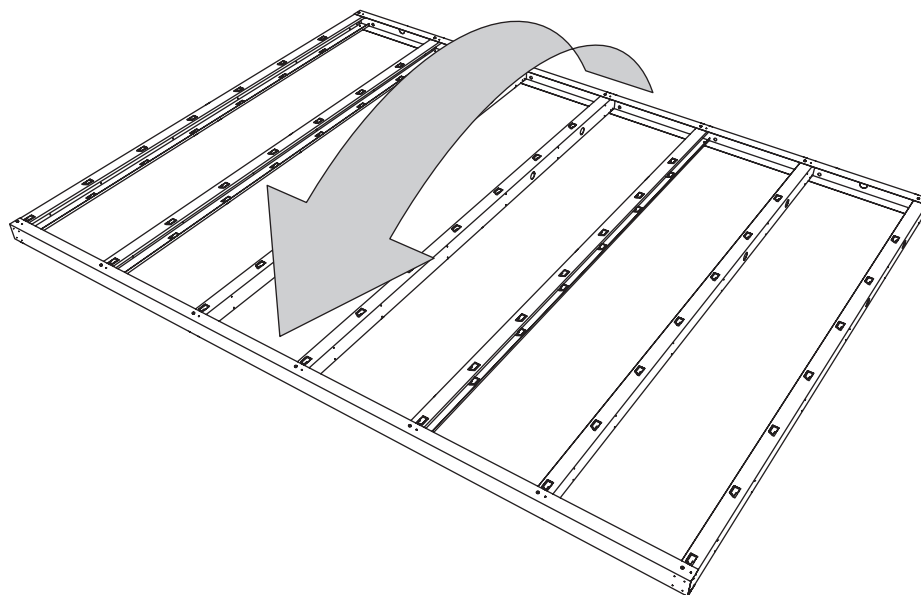
3X

B/D/F Paroi / Wand / Wall / Wand

POW

3X

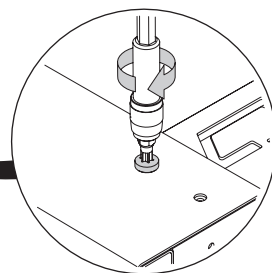
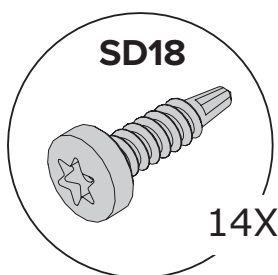

B/D/F Paroi / Wand / Wall / Wand

POW

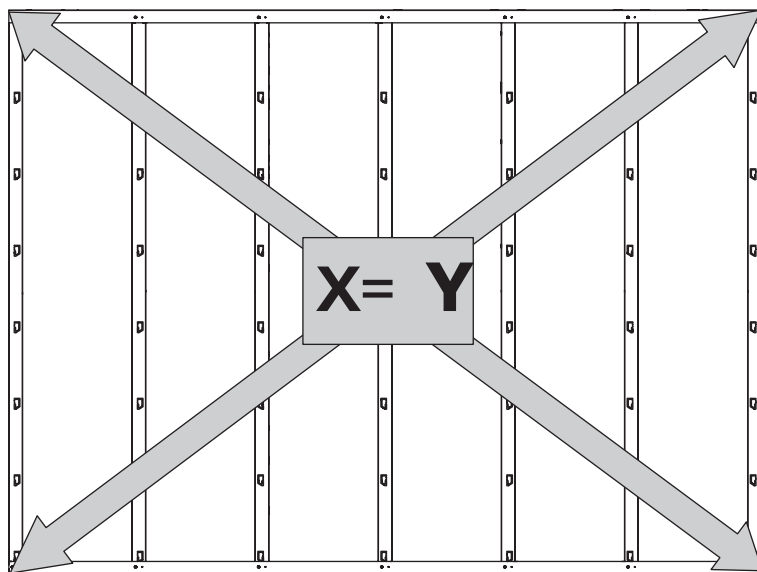
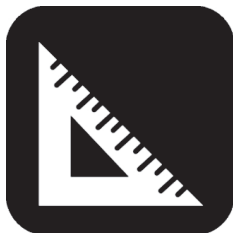
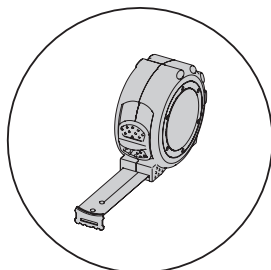

B/D/F Paroi / Wand / Wall / Wand

POW

3X

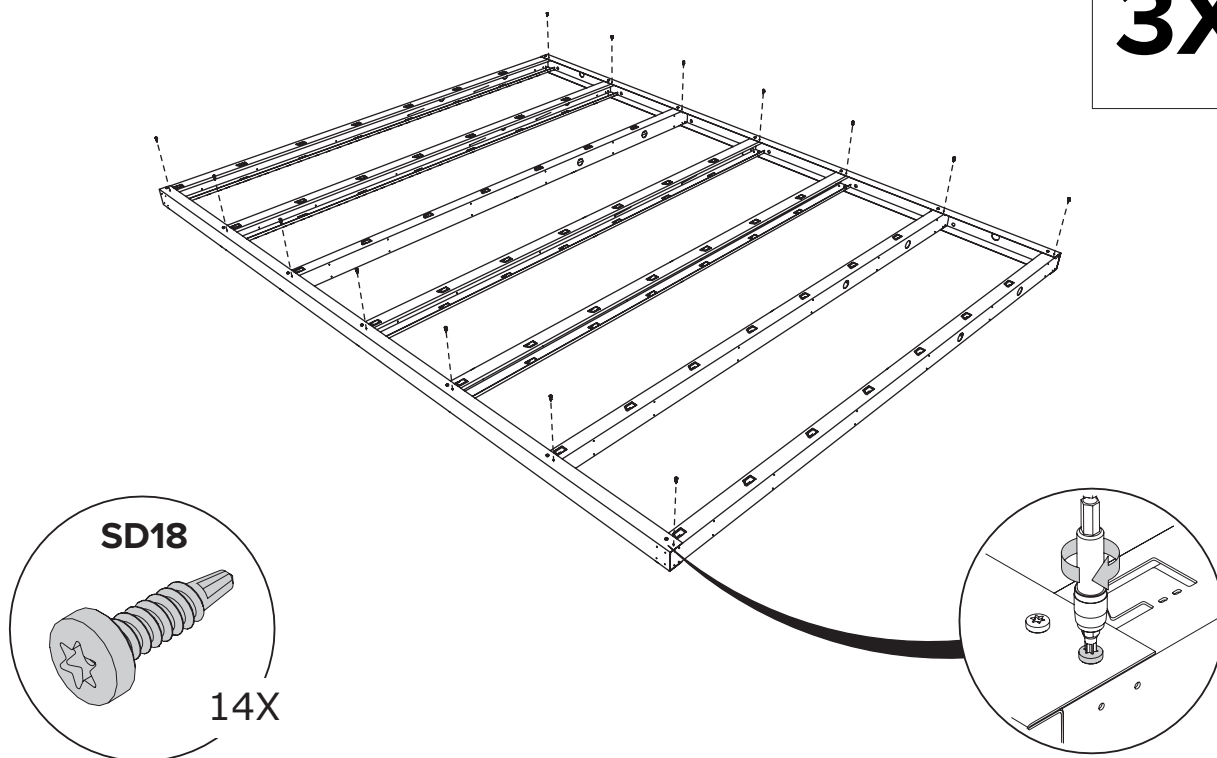

B/D/F Paroi / Wand / Wall / Wand

POW

Tourner encadrement / Kader omdraaien / Turn Frame / Rahmen umdrehen

3X

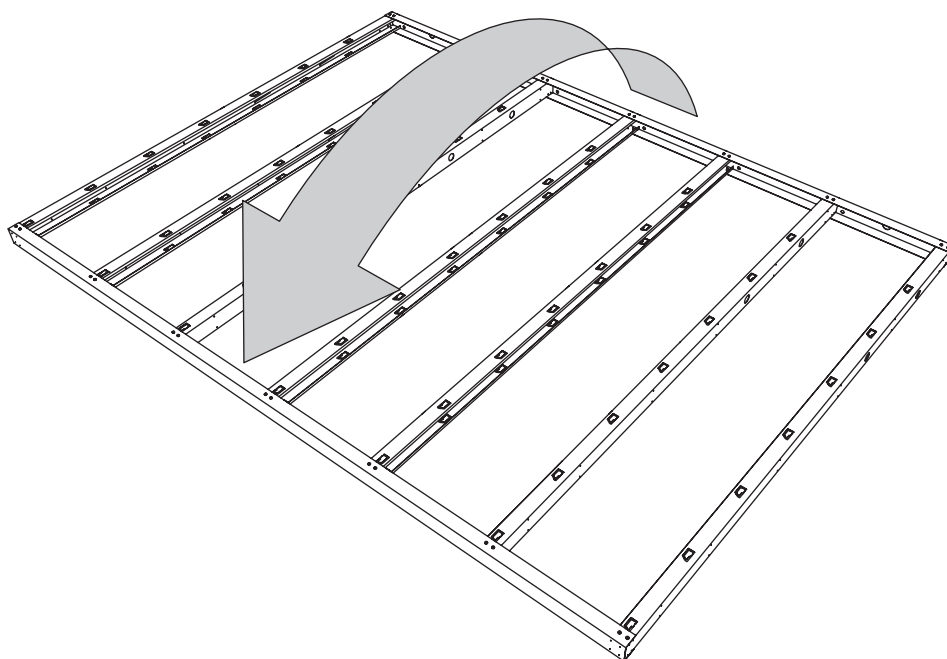

B/D/F Paroi / Wand / Wall / Wand

POW

3X

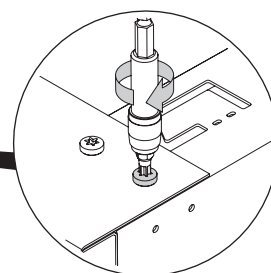
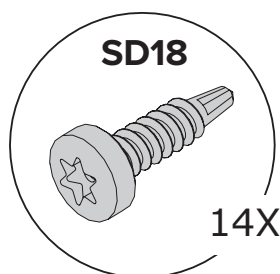

B/D/F Paroi / Wand / Wall / Wand

POW

B/D/F Paroi / Wand / Wall / Wand

POW

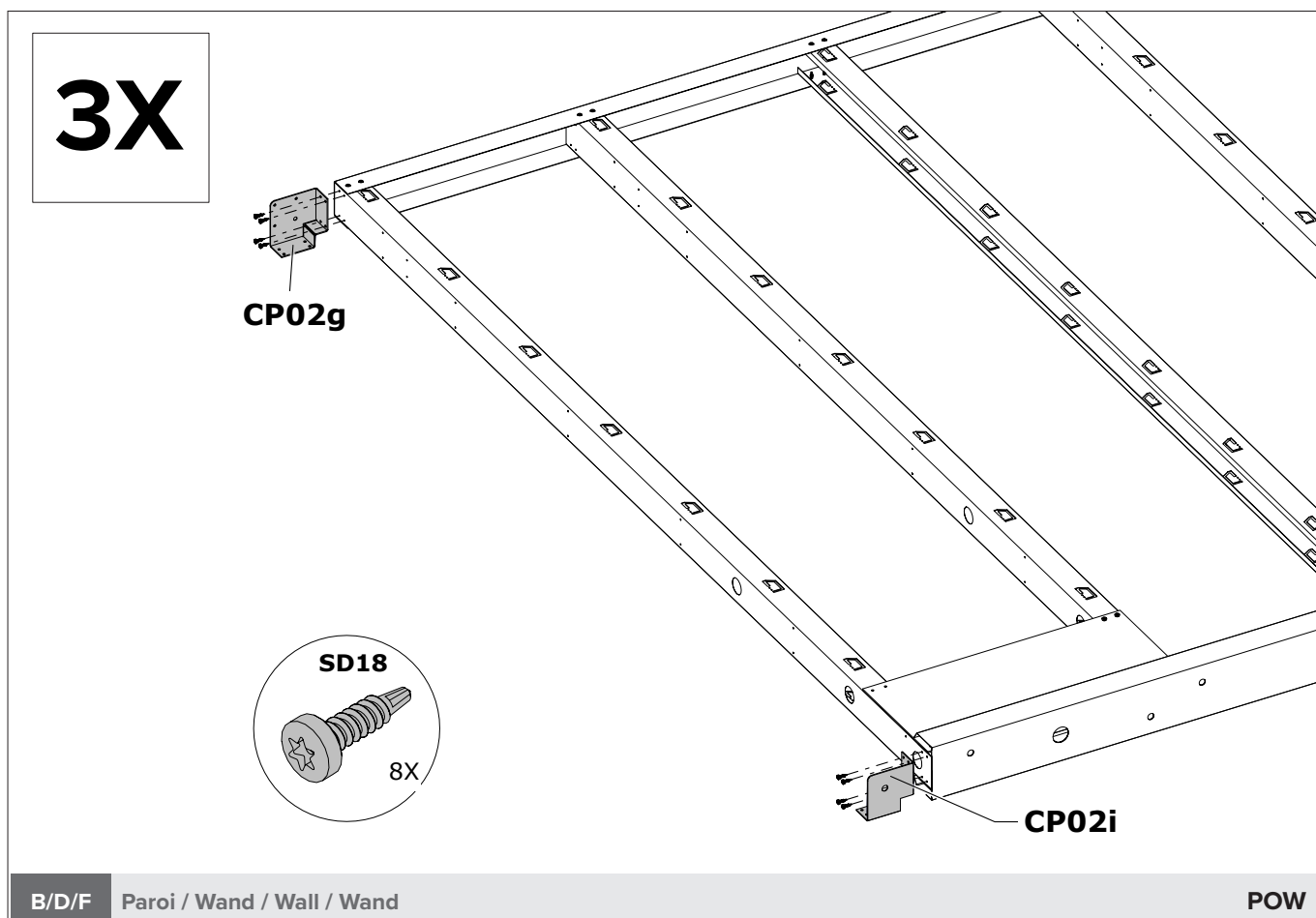
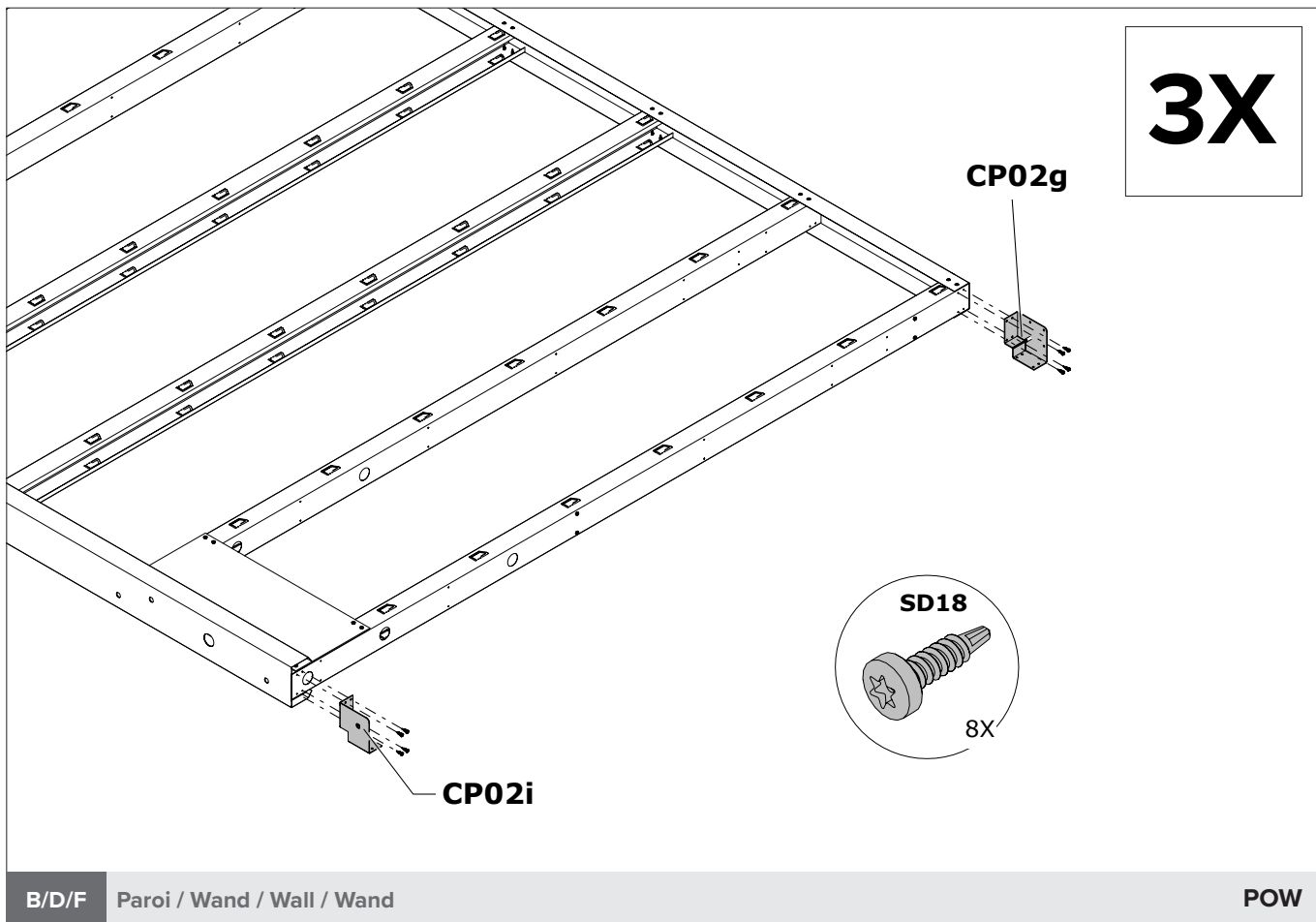

2X = A1/A2

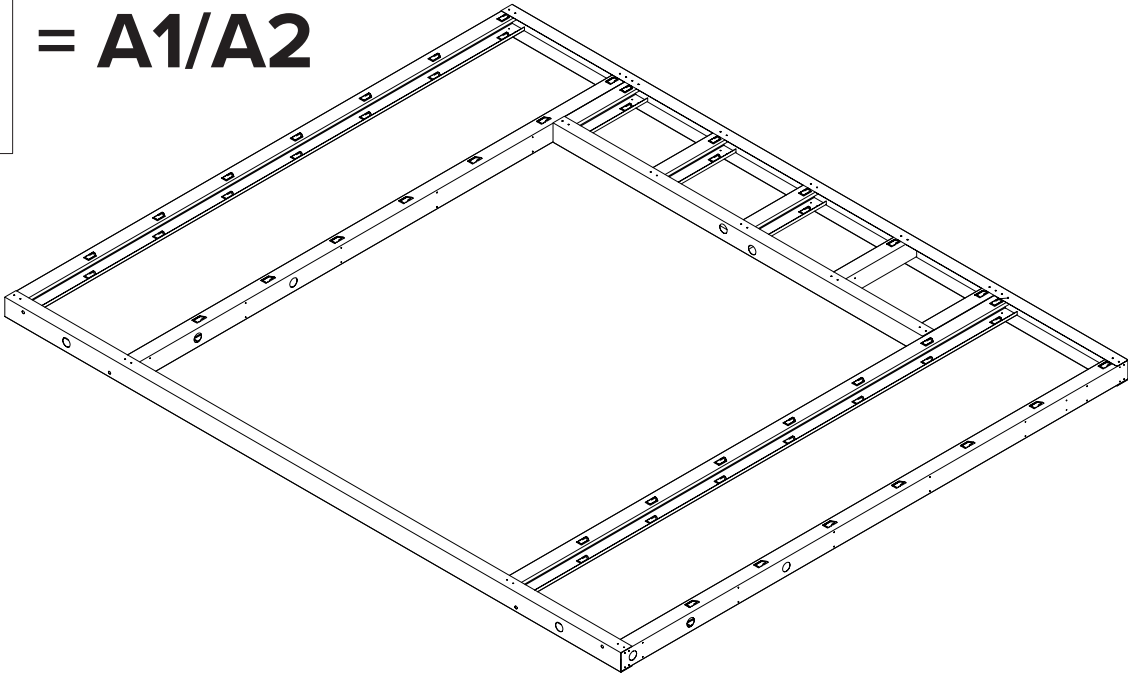

Le principe de la construction du mur, voir pages 9 à 15 (POW).
 Het principe van de opbouw van de wand, zie pagina 9 tot en met 15 (POW).
 The principle of building the wall, see pages 9 through 15 (POW).
 Das Prinzip des Baus der Mauer finden Sie auf den Seiten 9 bis 15 (POW).

A Paroi / Wand / Wall / Wand POW

2X

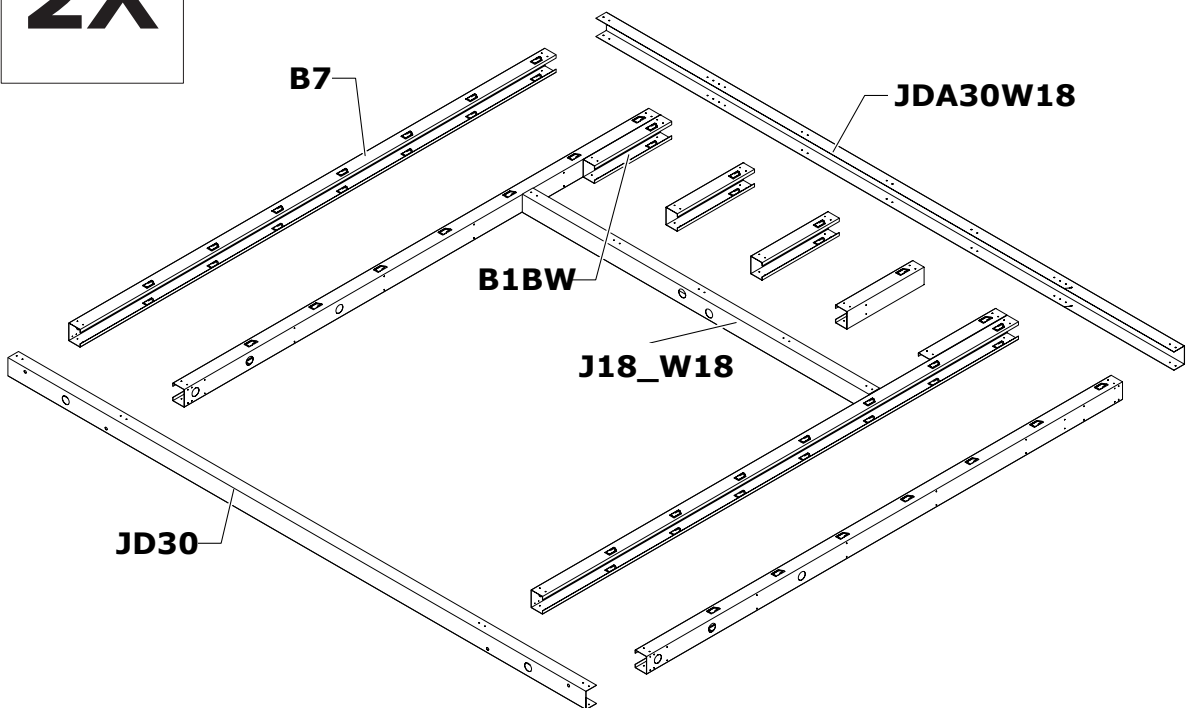

A Paroi / Wand / Wall / Wand POW

2X = C1/C2

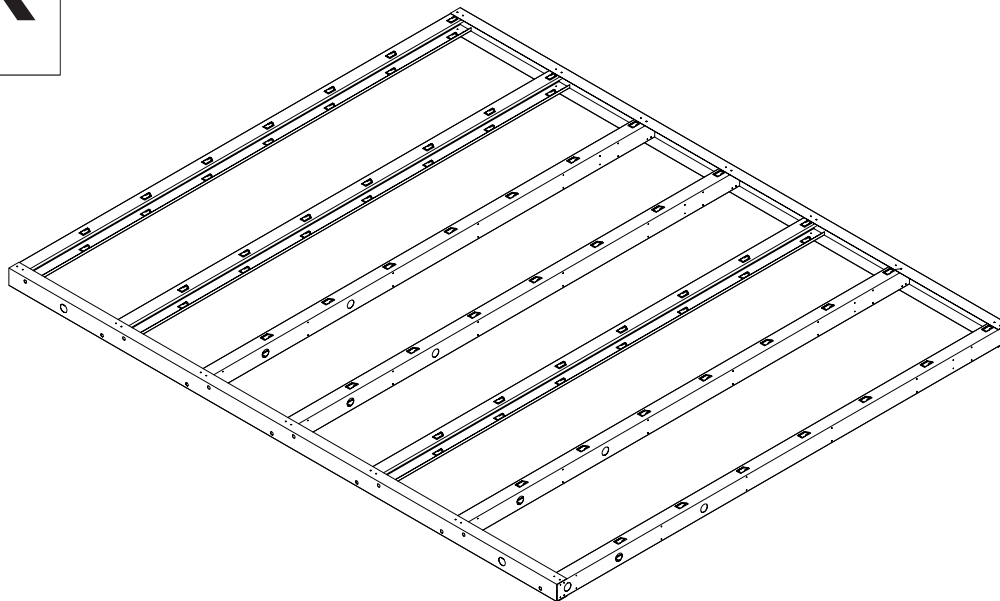

Le principe de la construction du mur, voir pages 9 à 15 (POW).
 Het principe van de opbouw van de wand, zie pagina 9 tot en met 15 (POW).
 The principle of building the wall, see pages 9 through 15 (POW).
 Das Prinzip des Baus der Mauer finden Sie auf den Seiten 9 bis 15 (POW).

C Paroi / Wand / Wall / Wand

2X

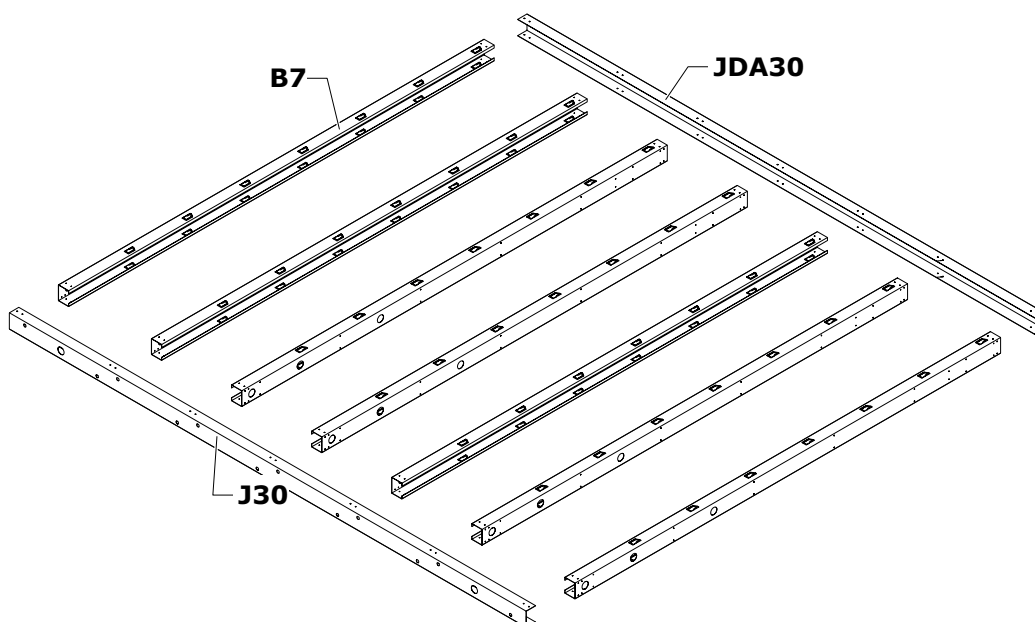

C Paroi / Wand / Wall / Wand

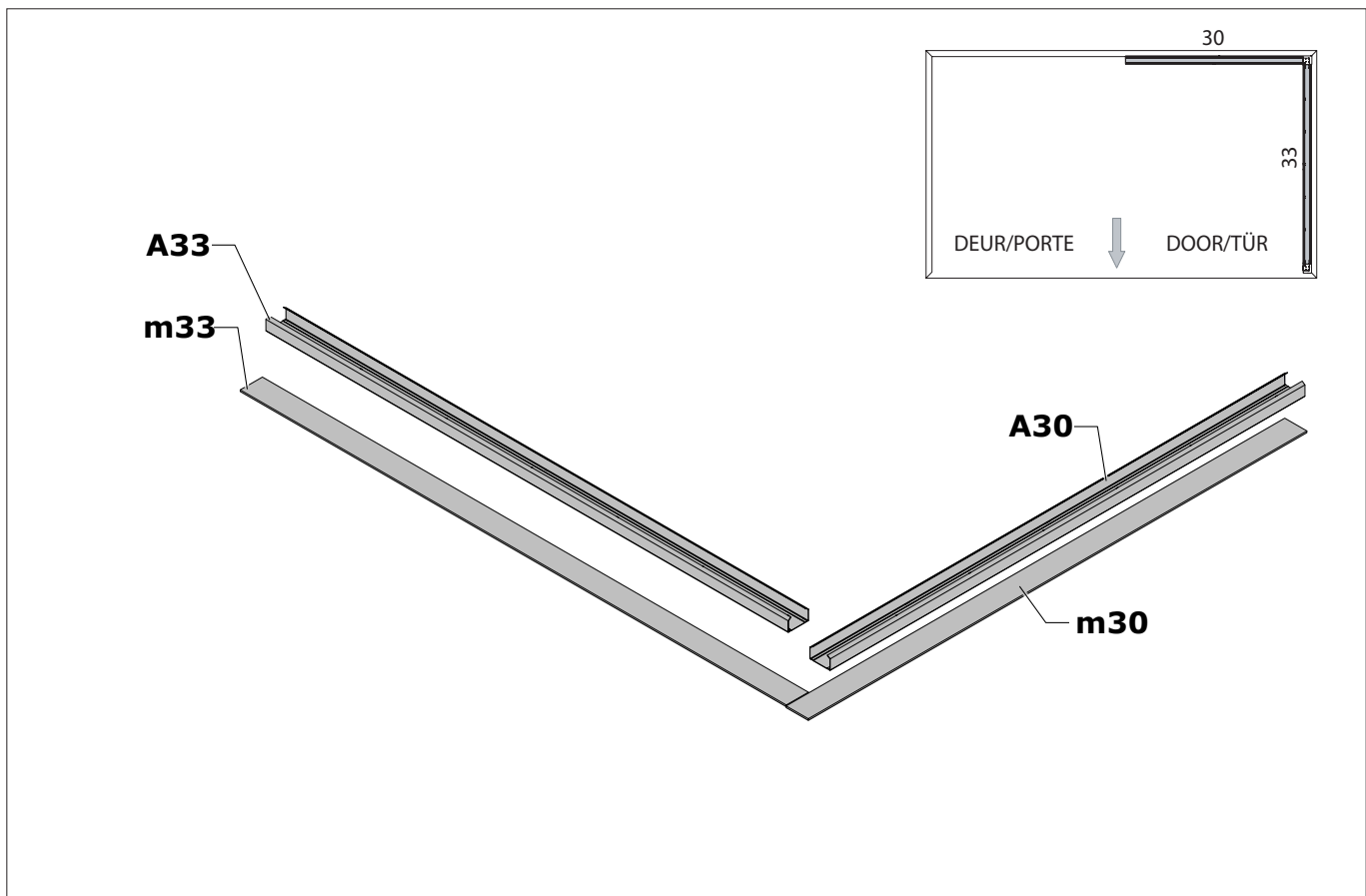

B/C Paroi / Wand / Wall / Wand

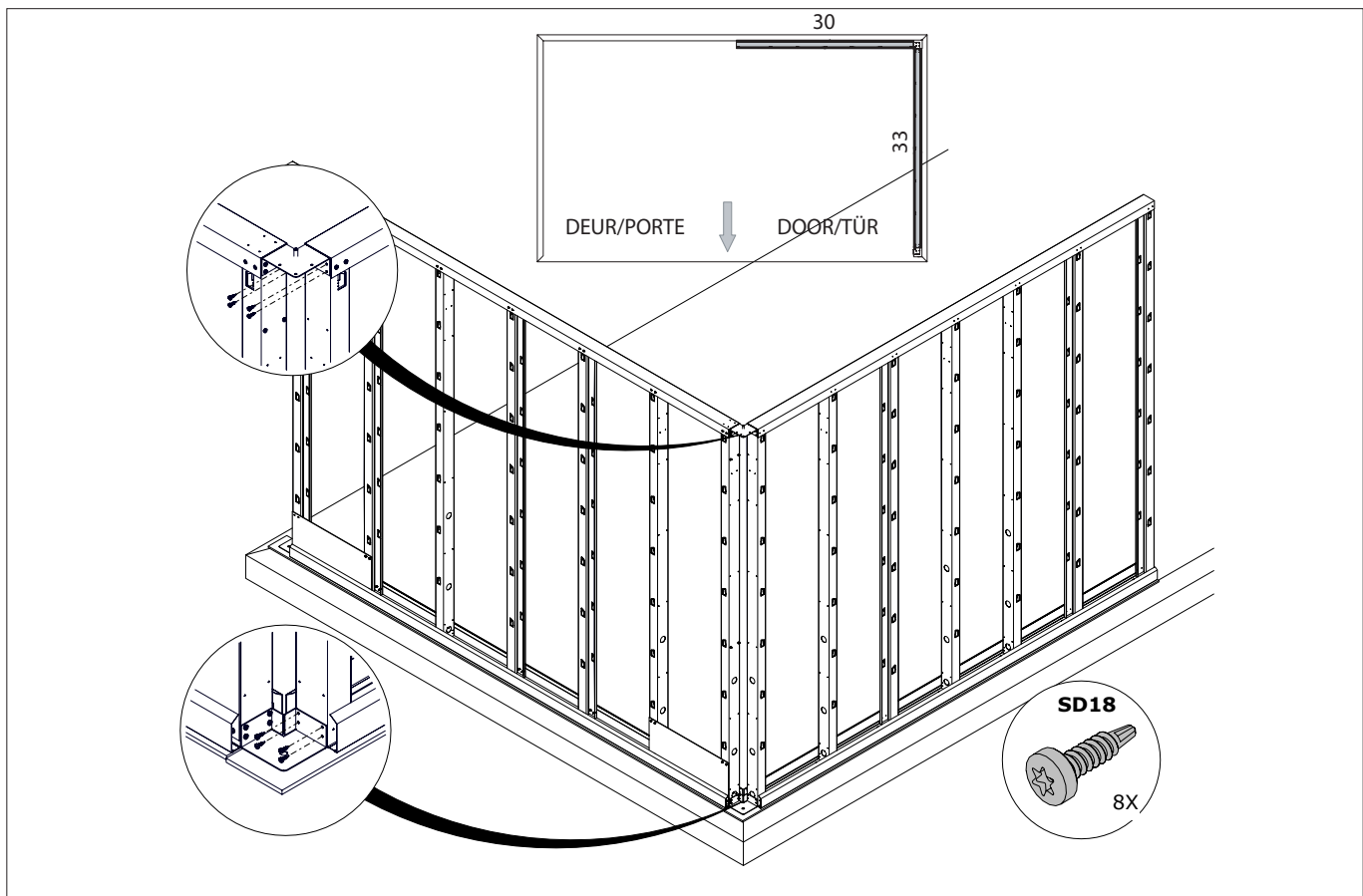

B/C Paroi / Wand / Wall / Wand

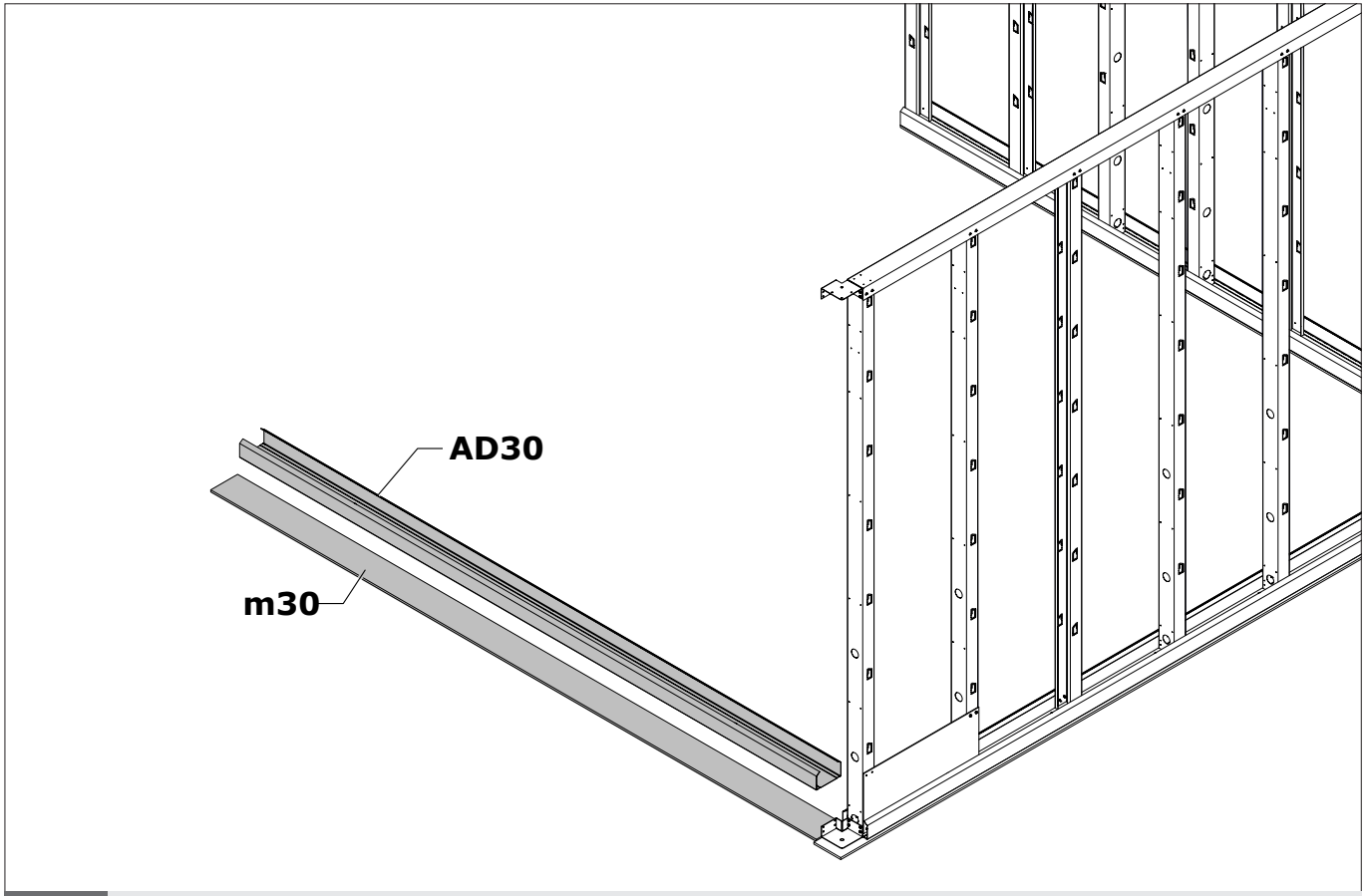

A Paroi / Wand / Wall / Wand

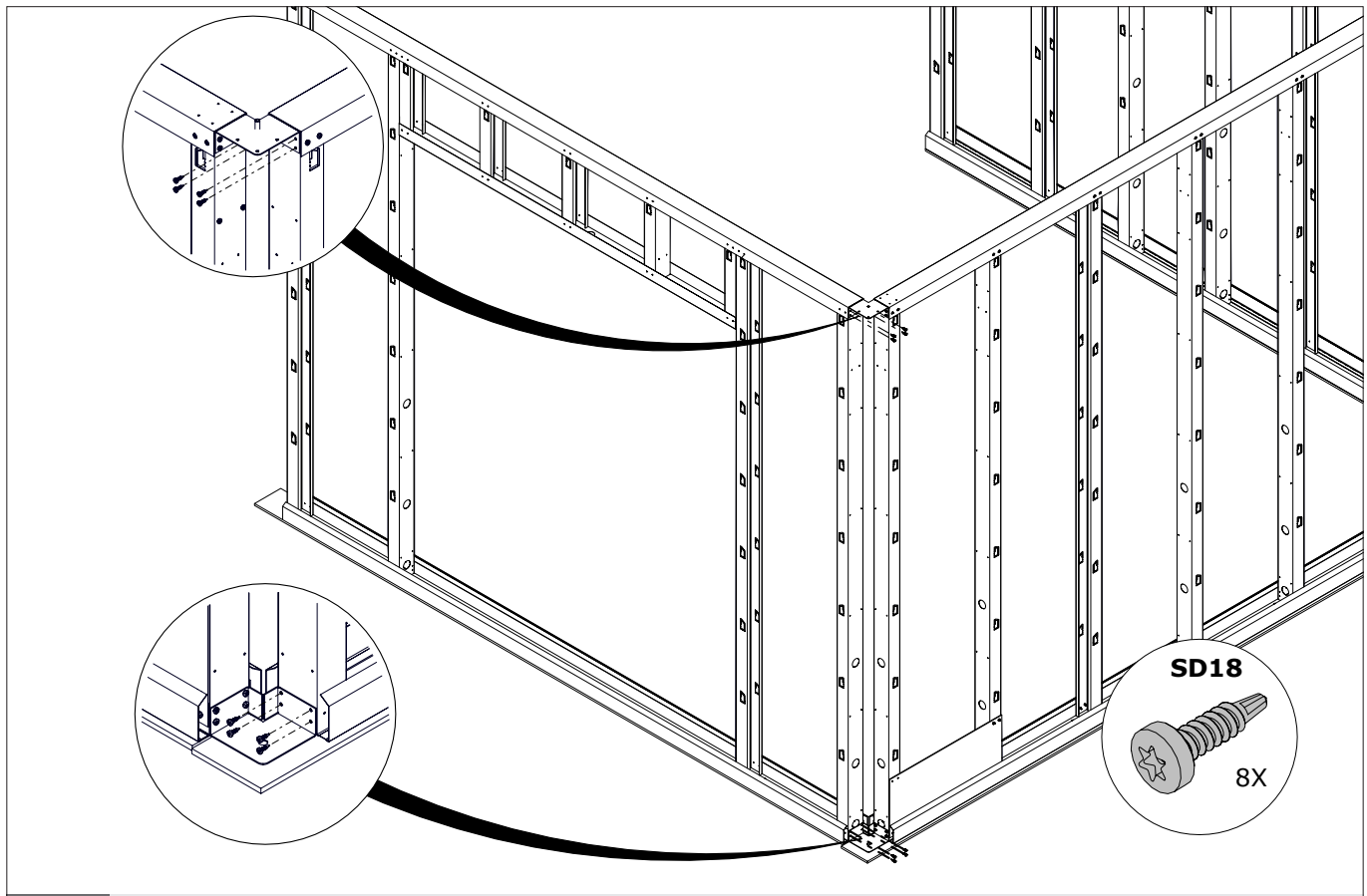

A/B/C Paroi / Wand / Wall / Wand

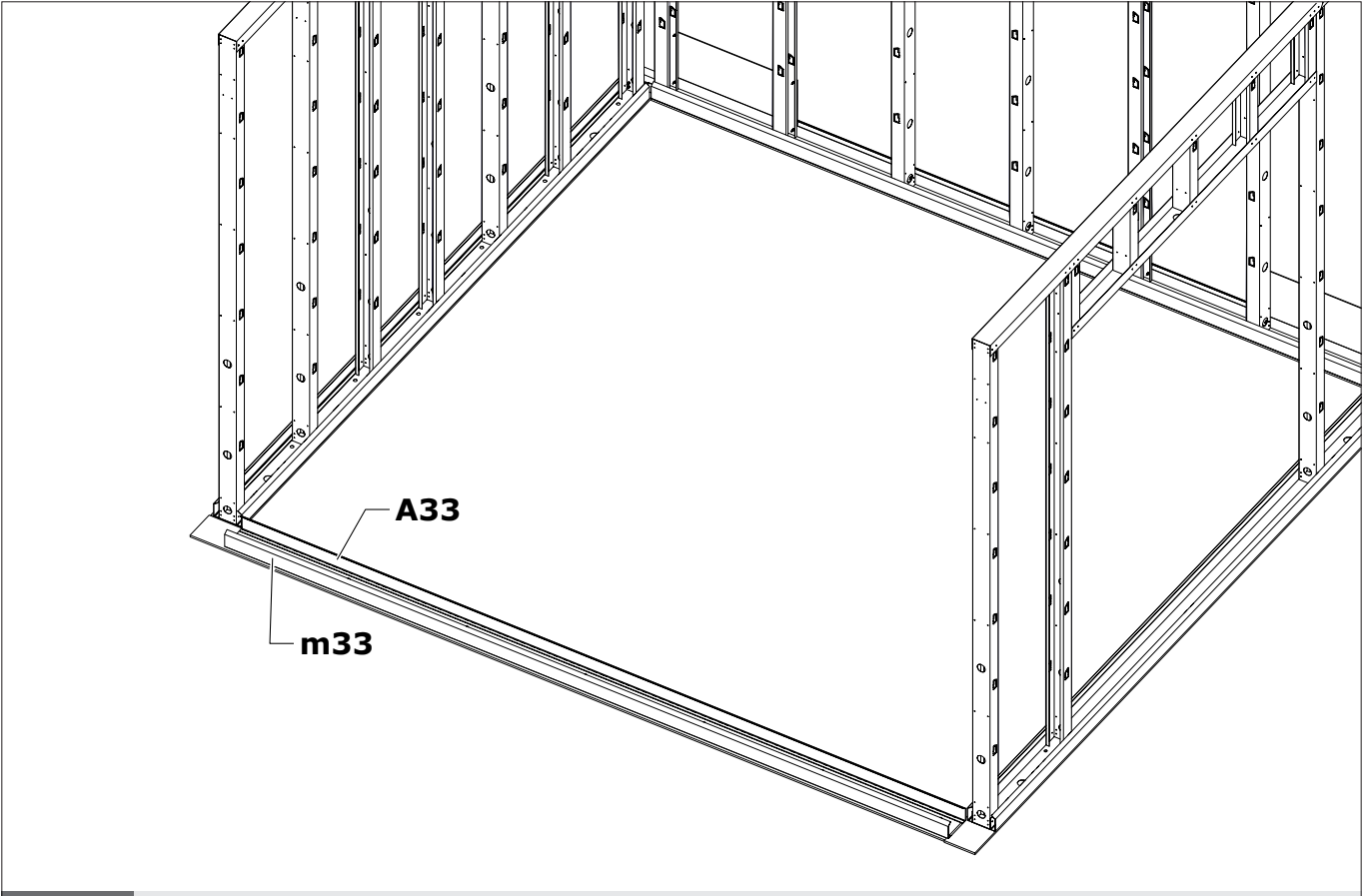

D Paroi / Wand / Wall / Wand

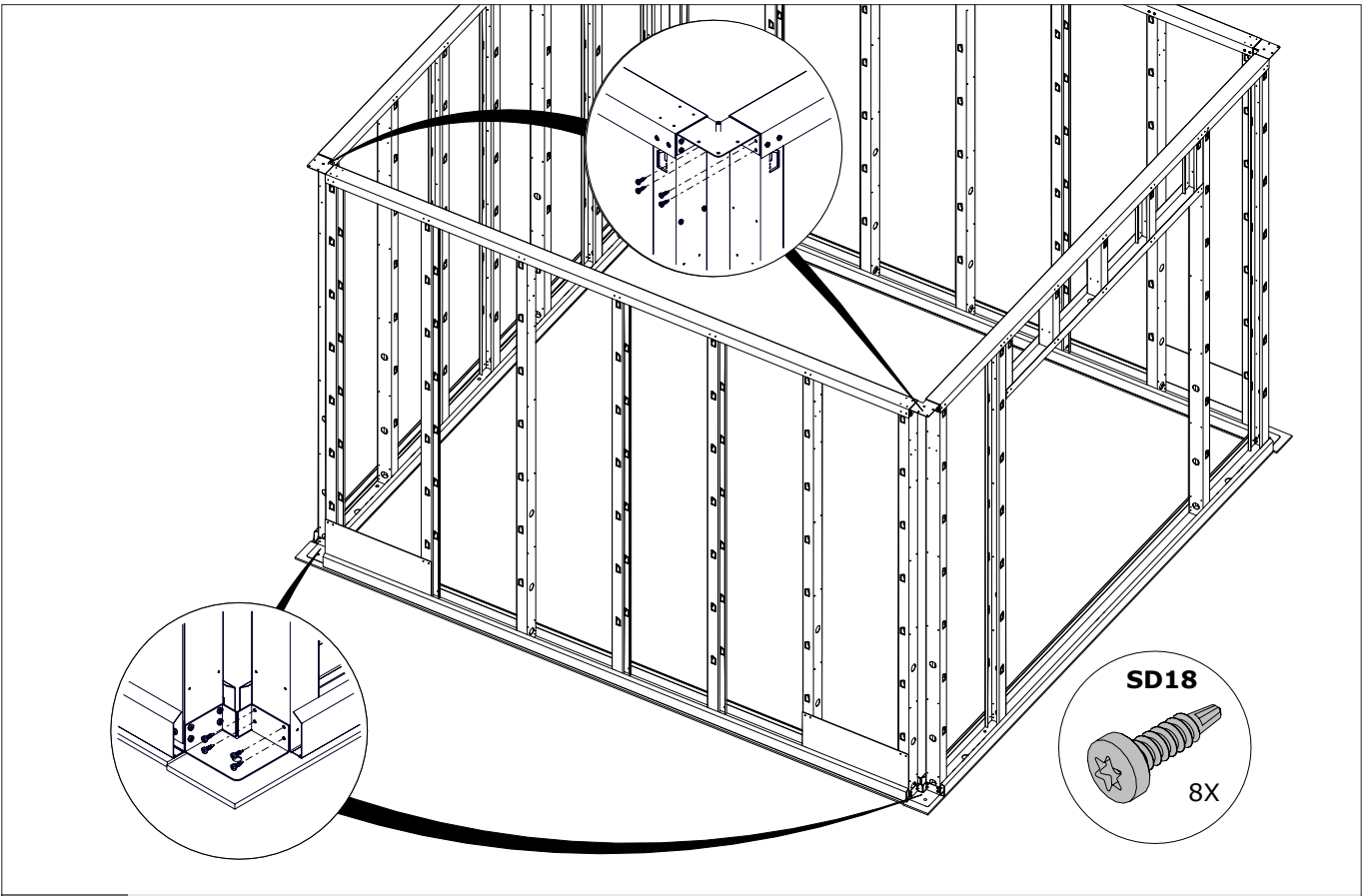

A/B/C/D Paroi / Wand / Wall / Wand

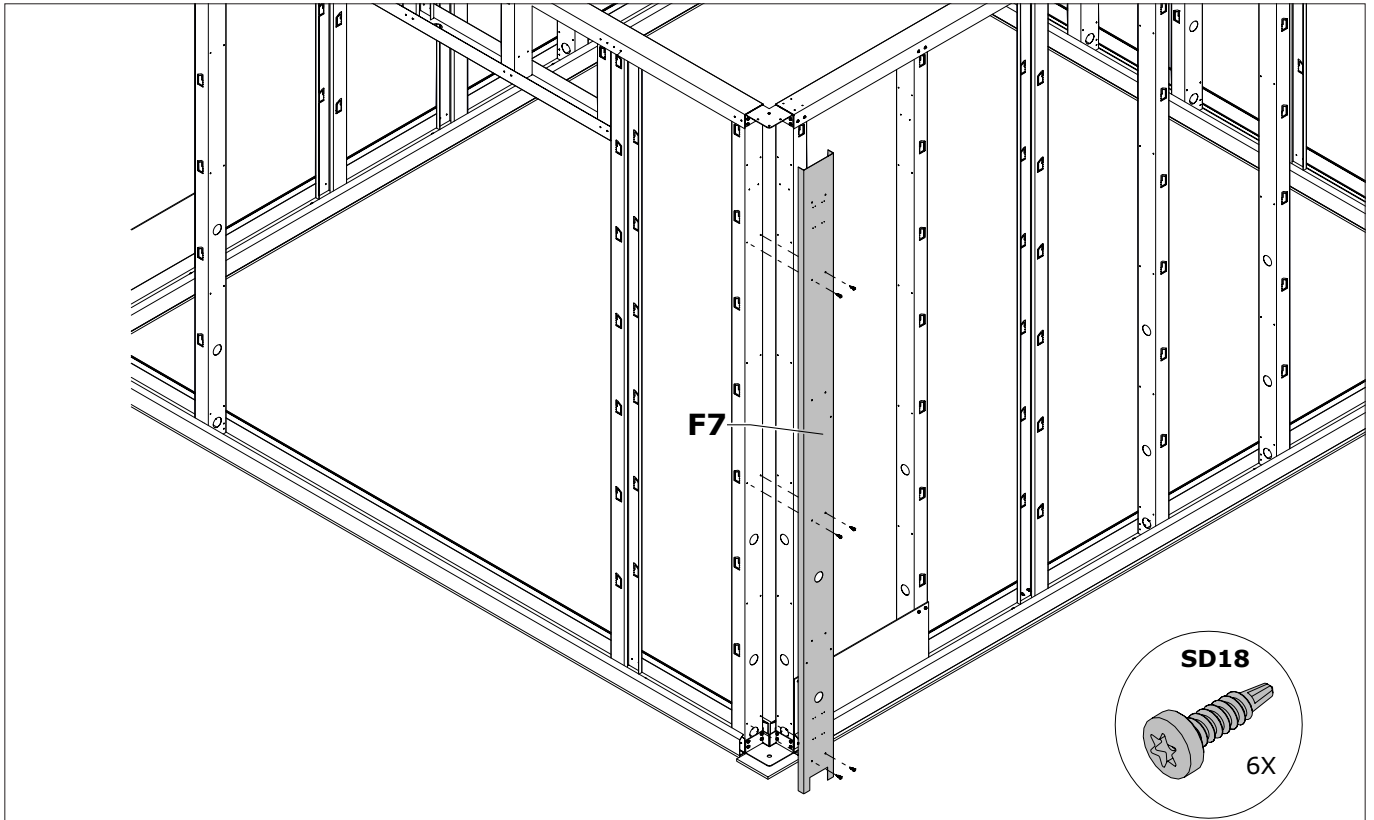

A

Paroi / Wand / Wall / Wand

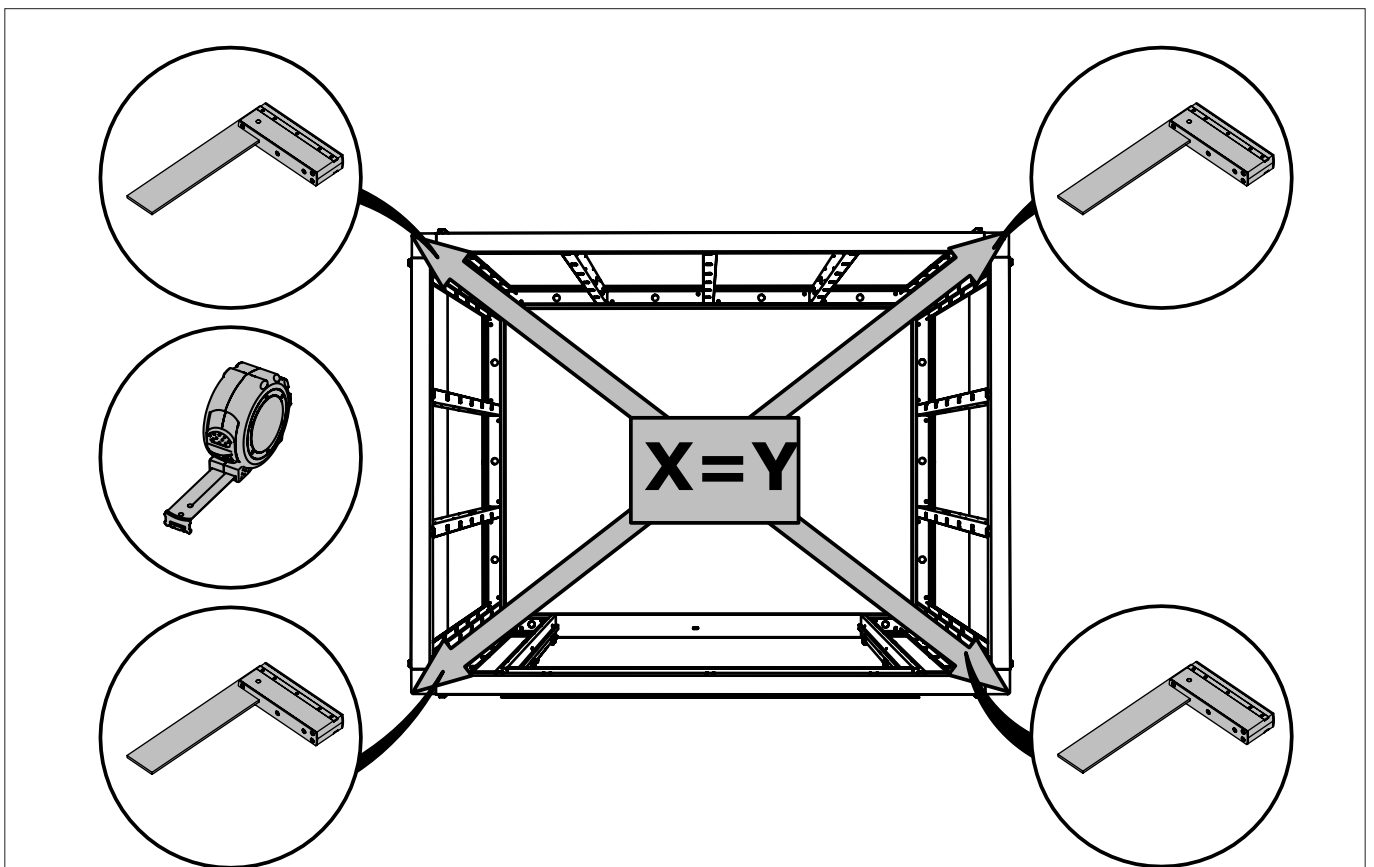

Anchorage / Verankering / Anchoring / Verankerung

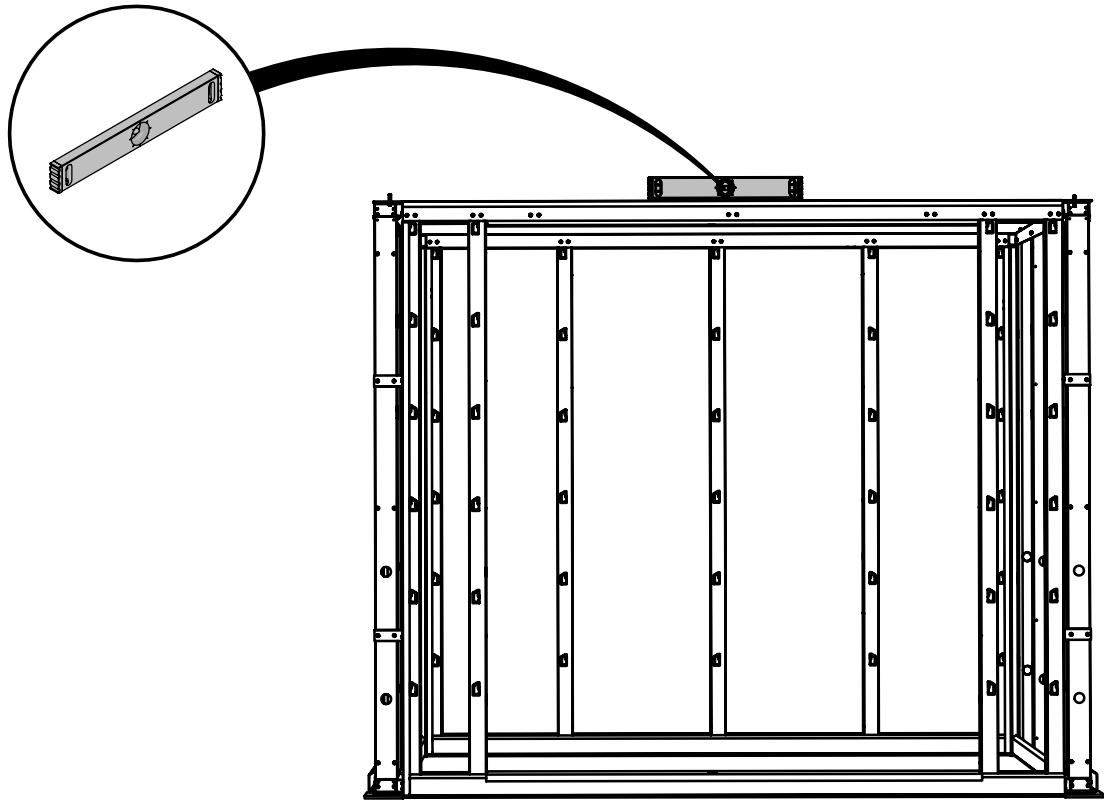

Ancrage / Verankering / Anchoring / Verankerung

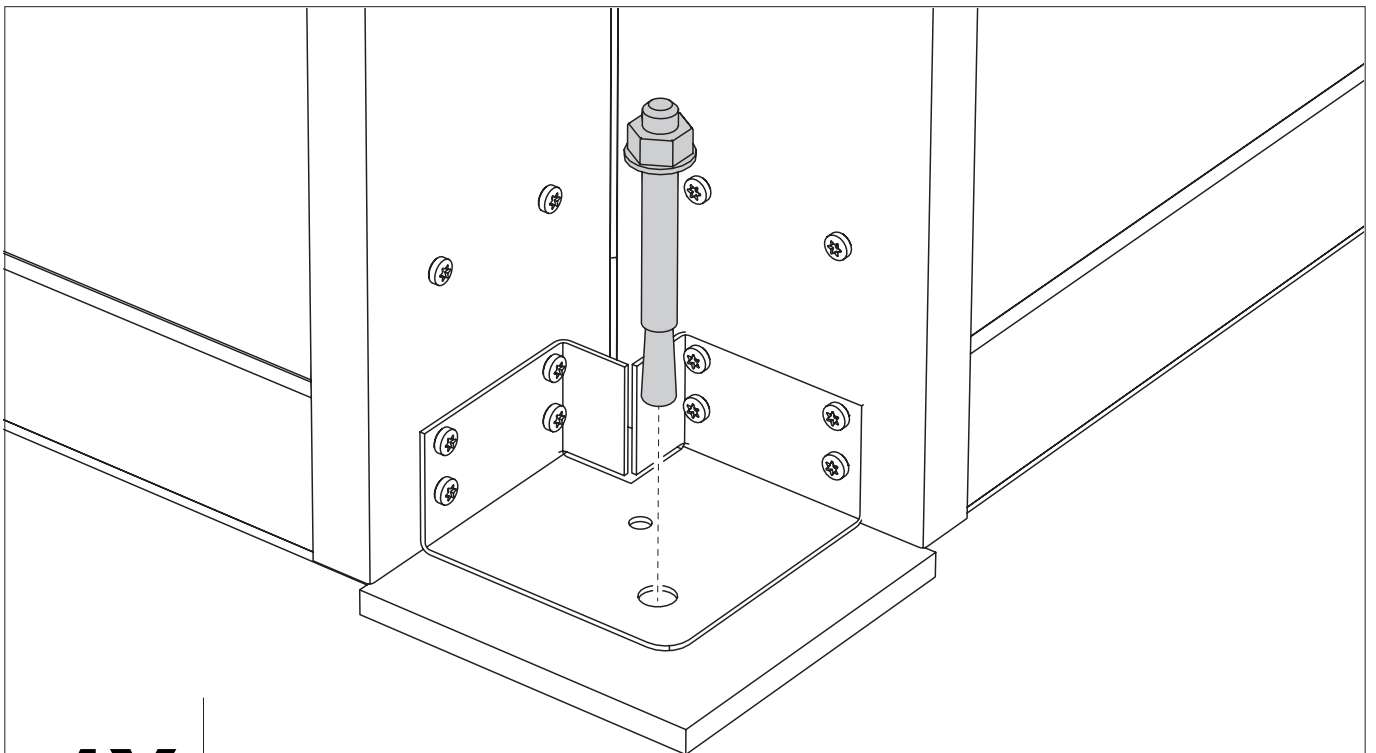

4X

Ancrage / Verankering / Anchoring / Verankerung

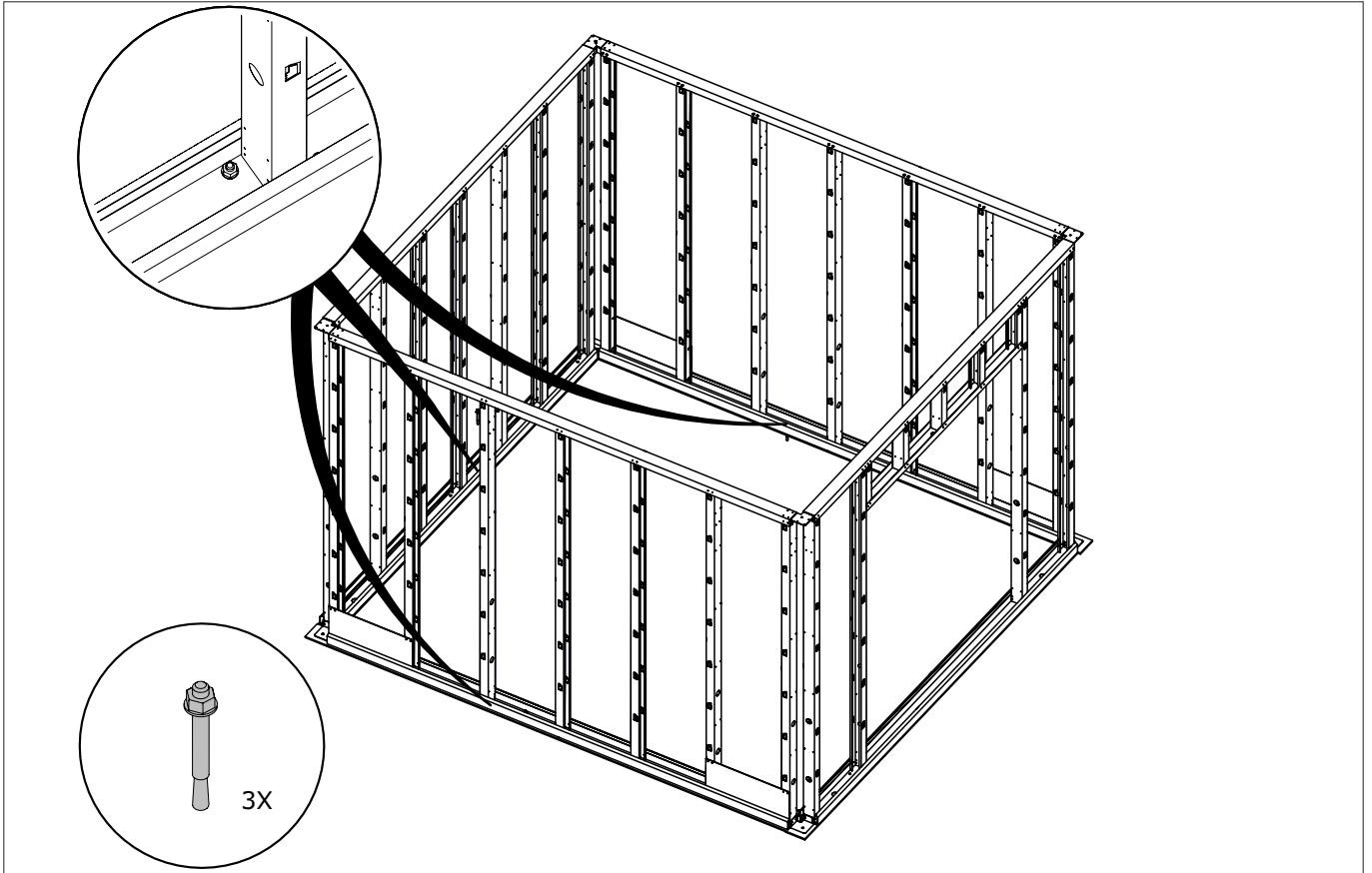

A/B/C/D Ancrage / Verankering / Anchoring / Verankerung

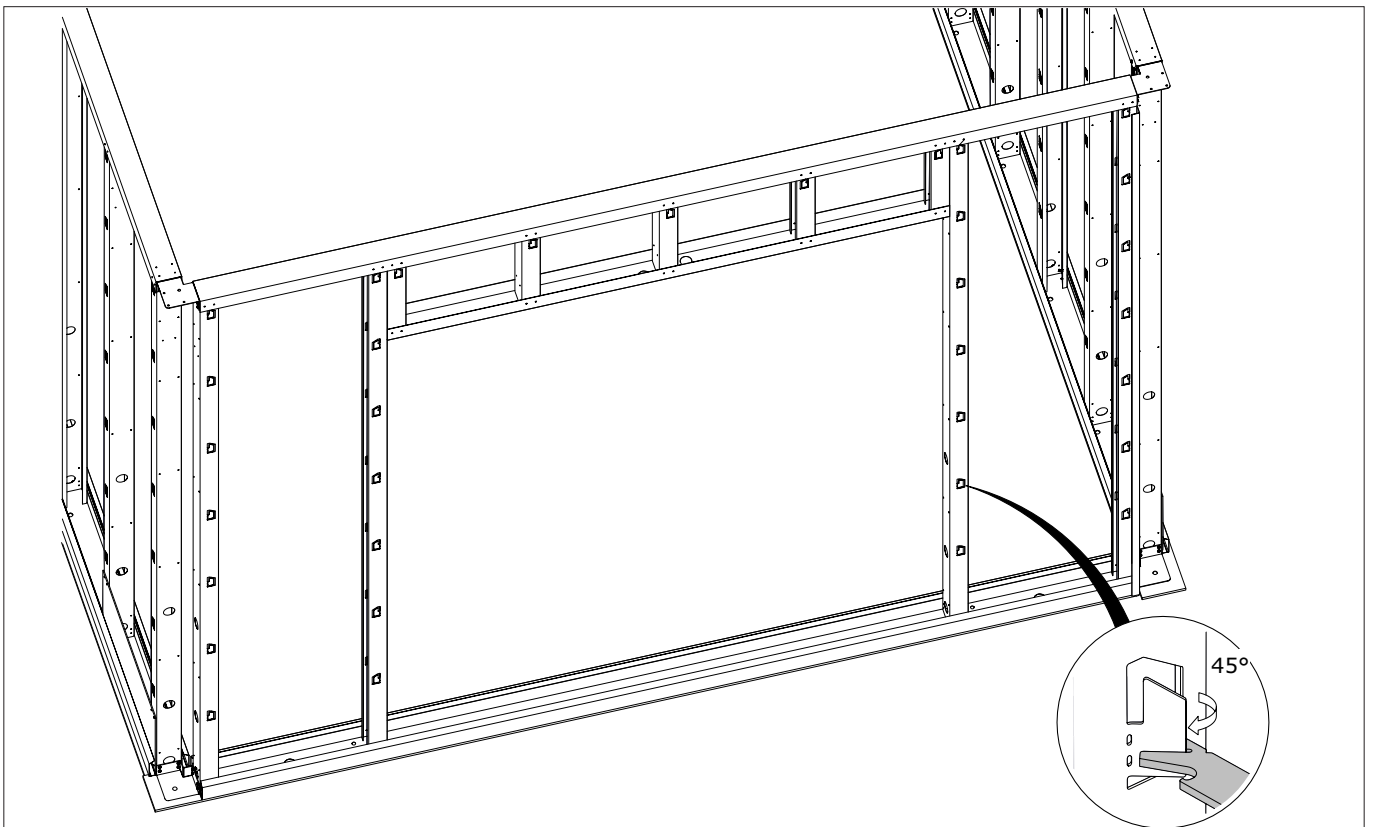

A Paroi / Wand / Wall / Wand

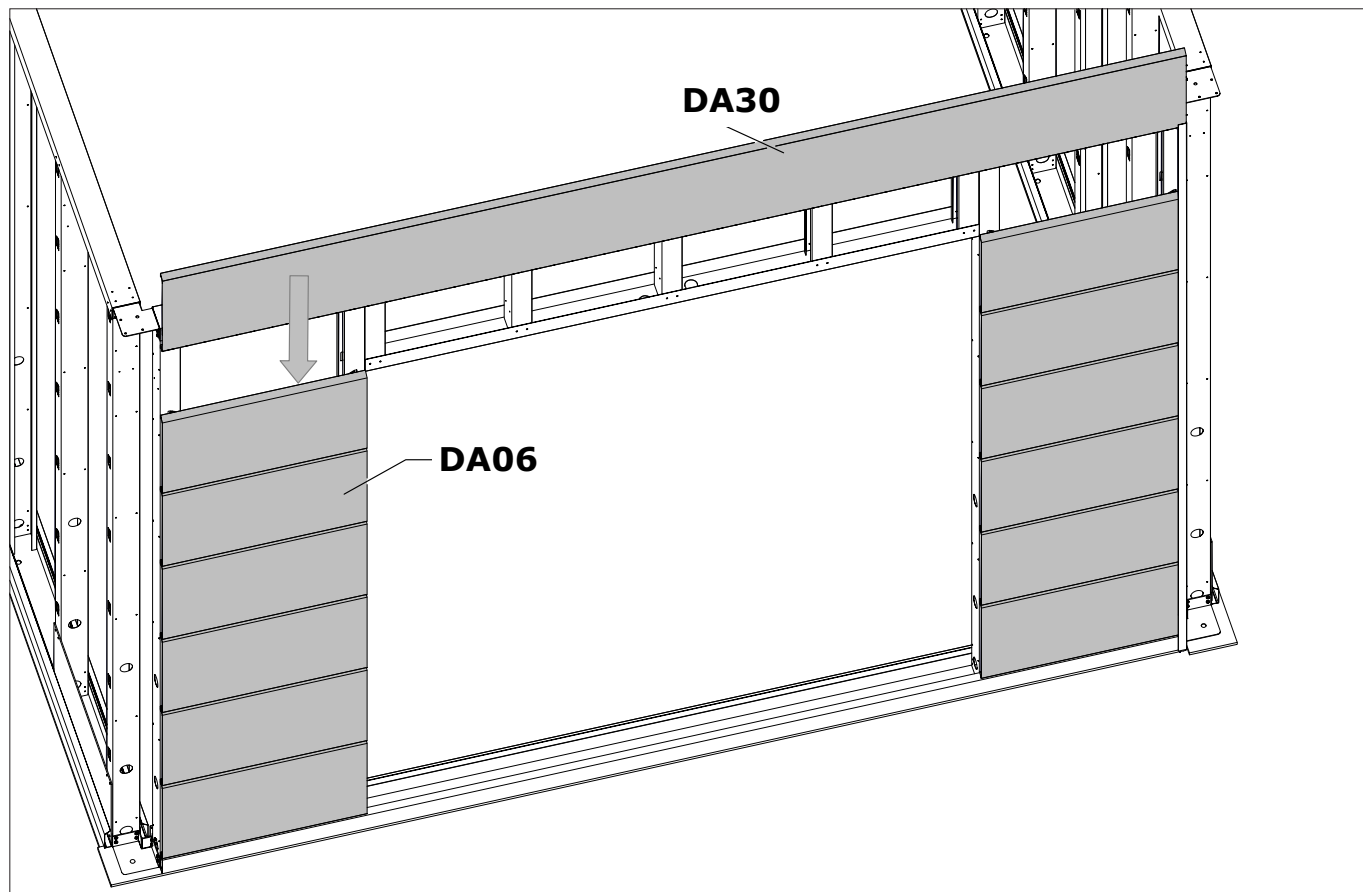

A Paroi / Wand / Wall / Wand

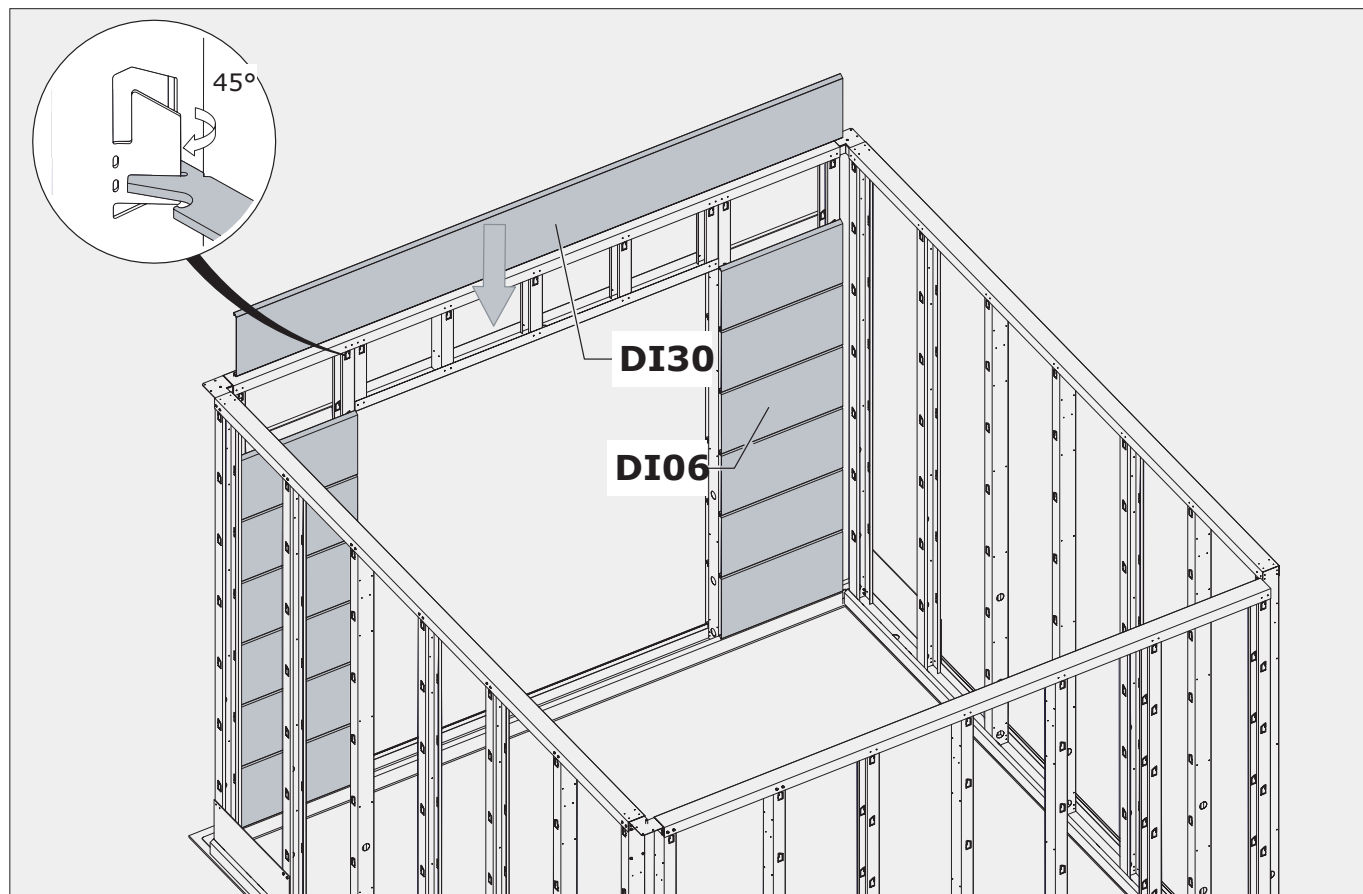

A Paroi / Wand / Wall / Wand

Option / Optie / Option / Option

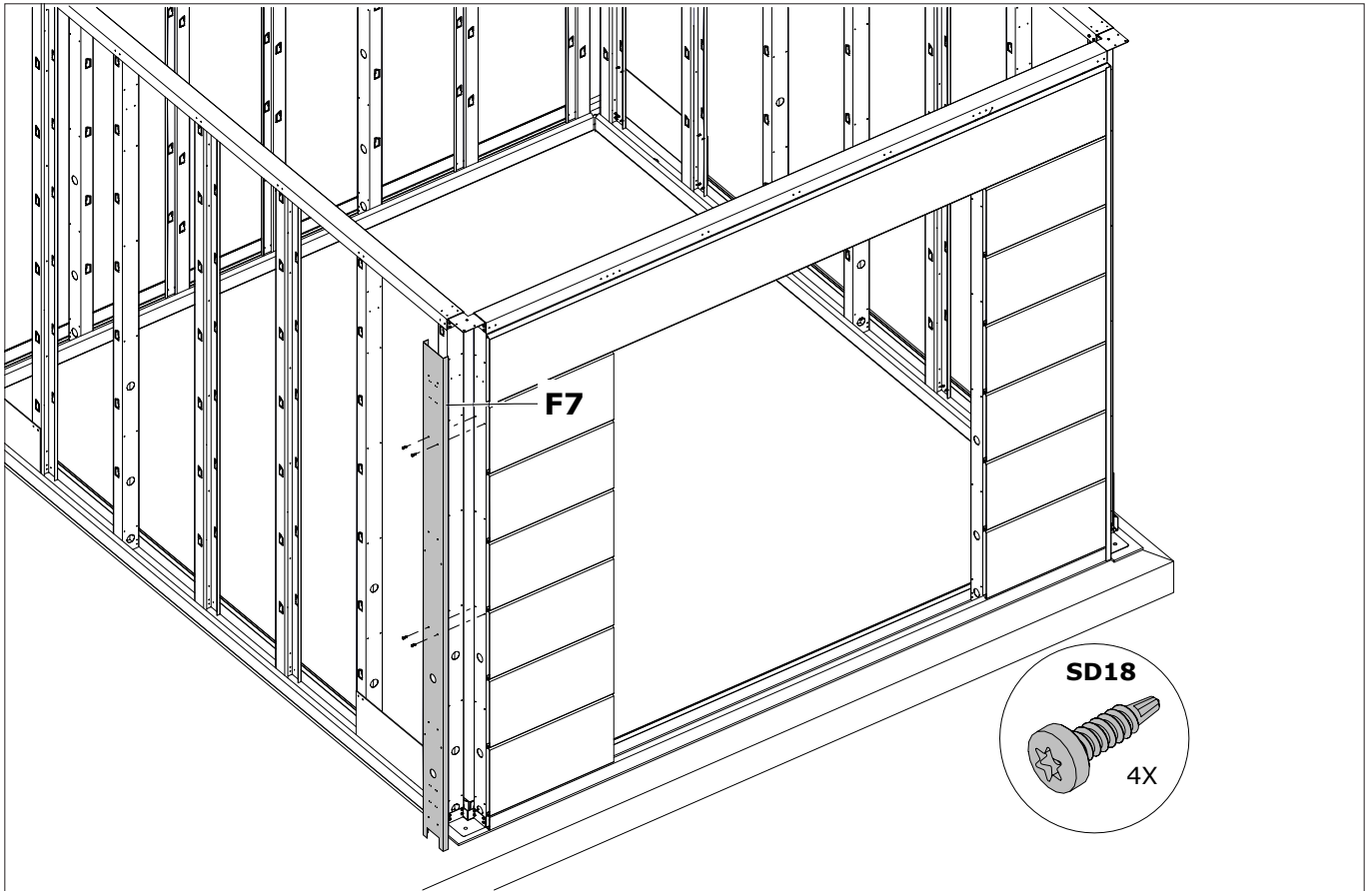

A Paroi / Wand / Wall / Wand

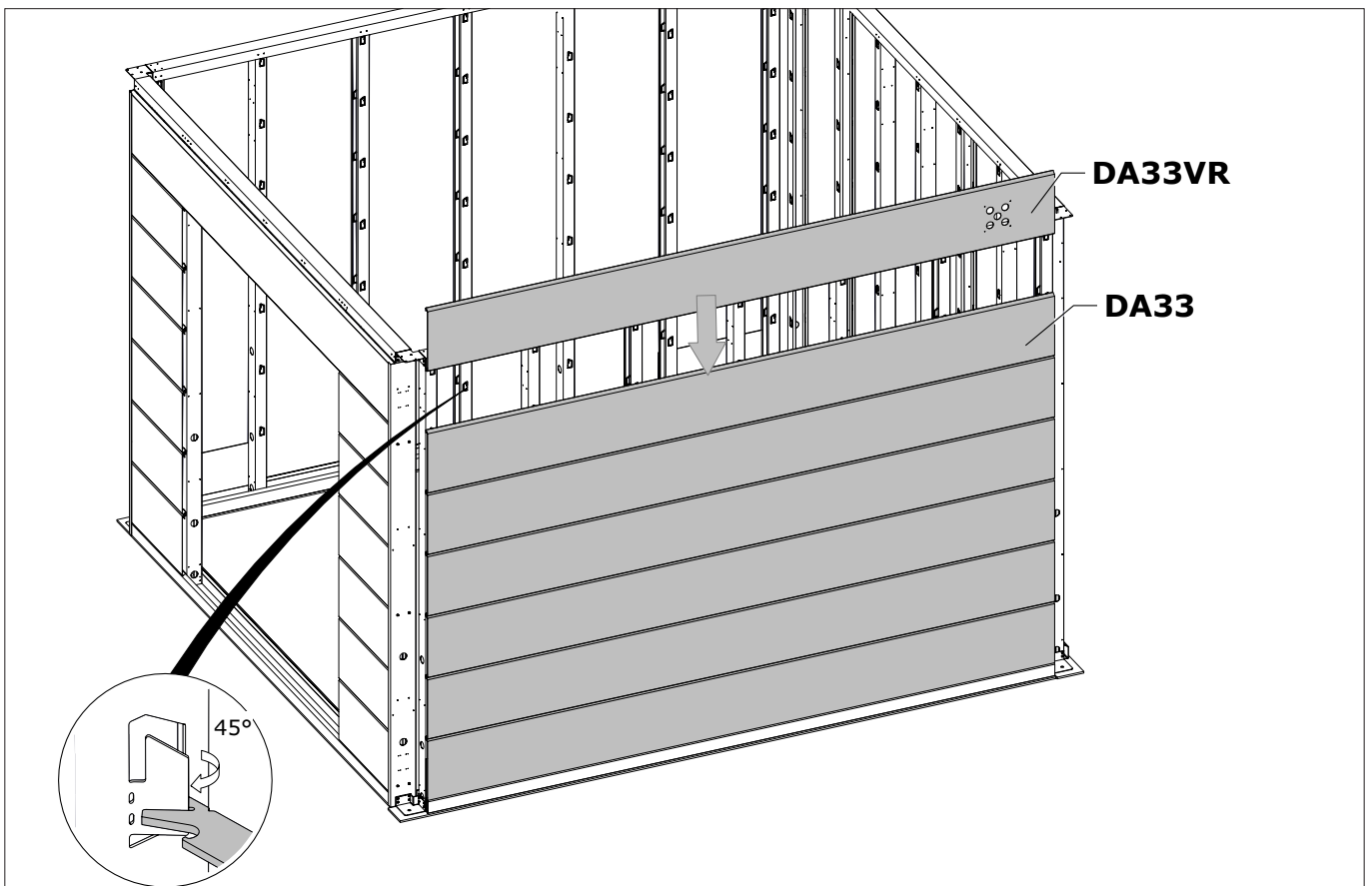

B Paroi / Wand / Wall / Wand

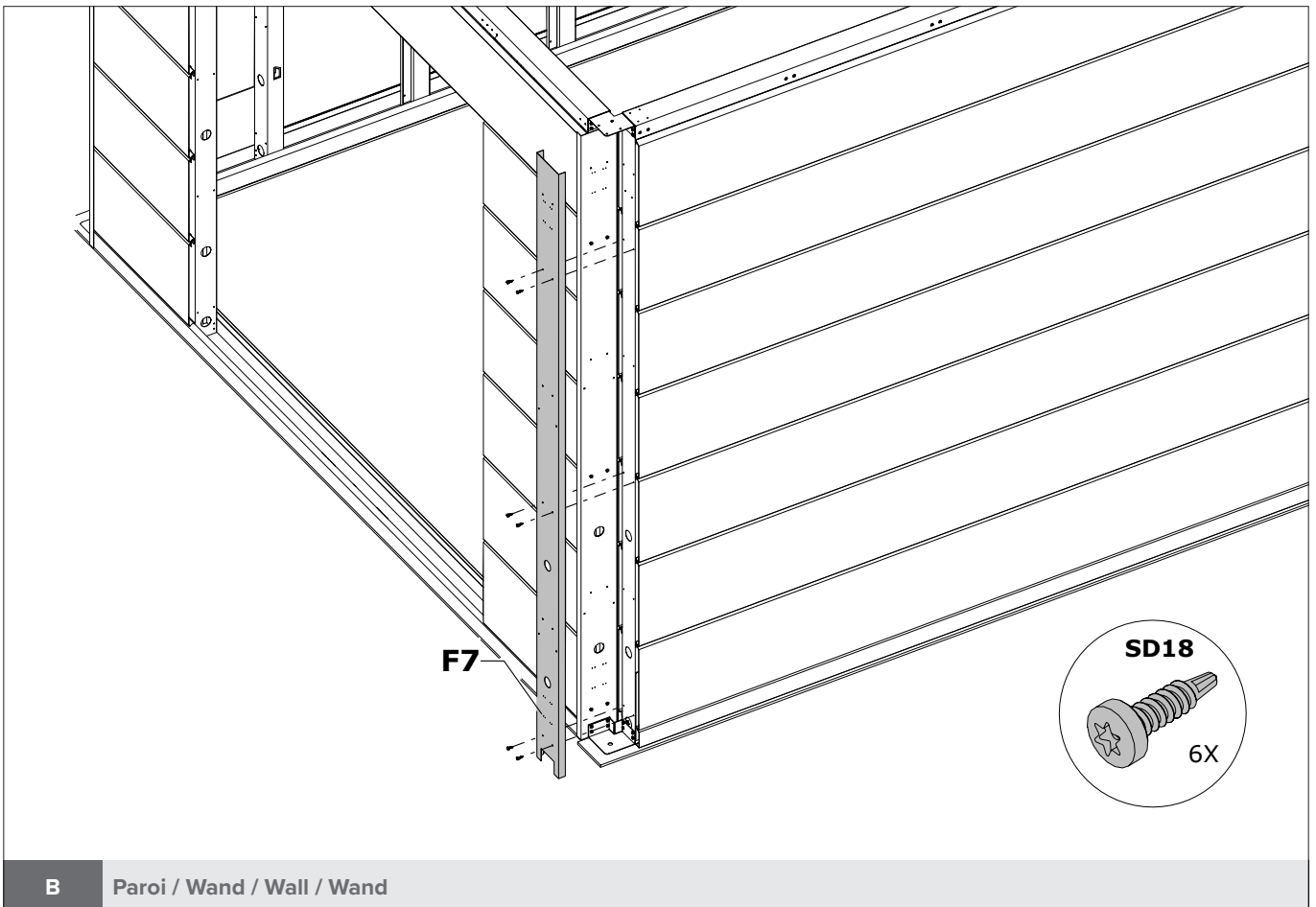
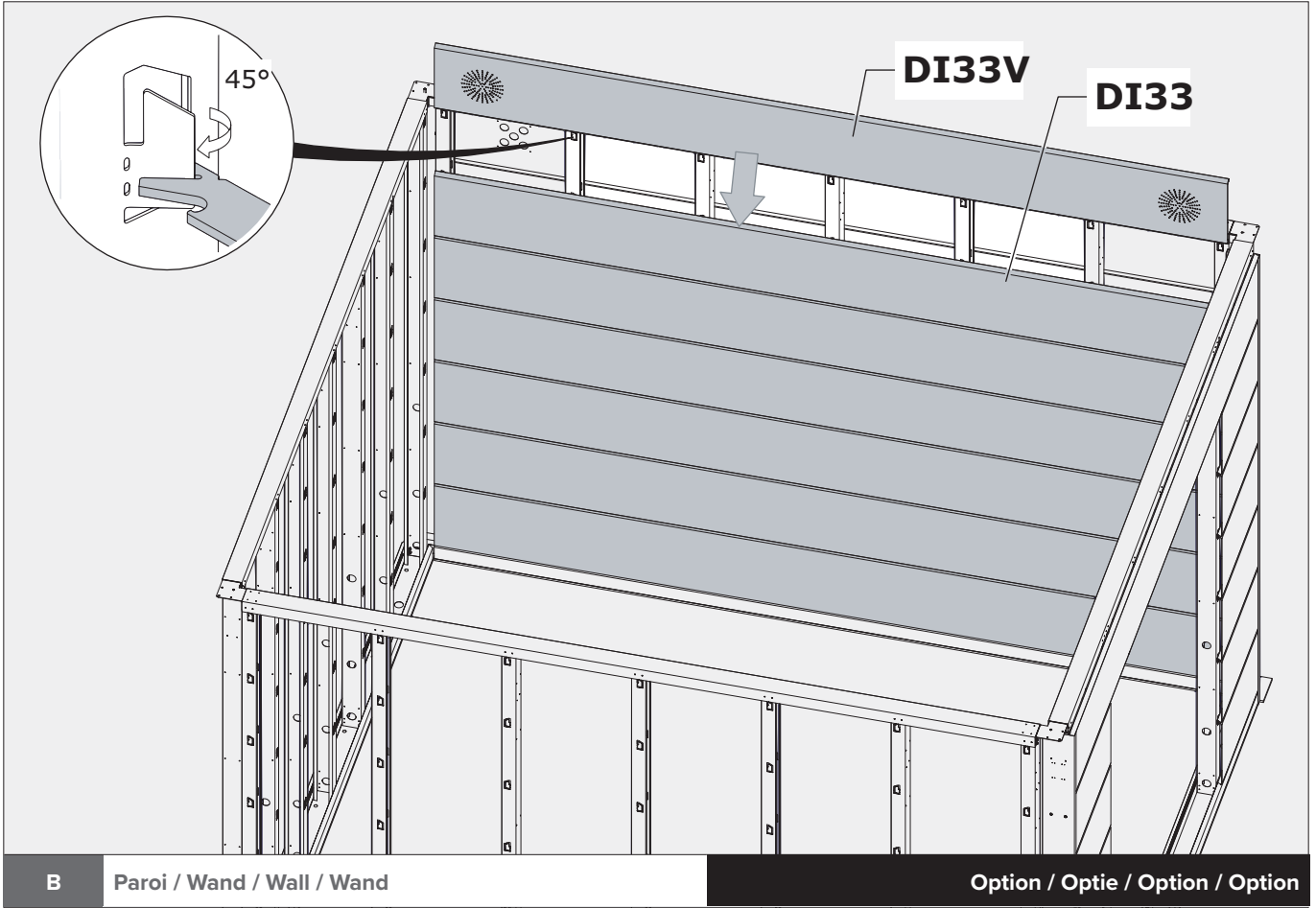

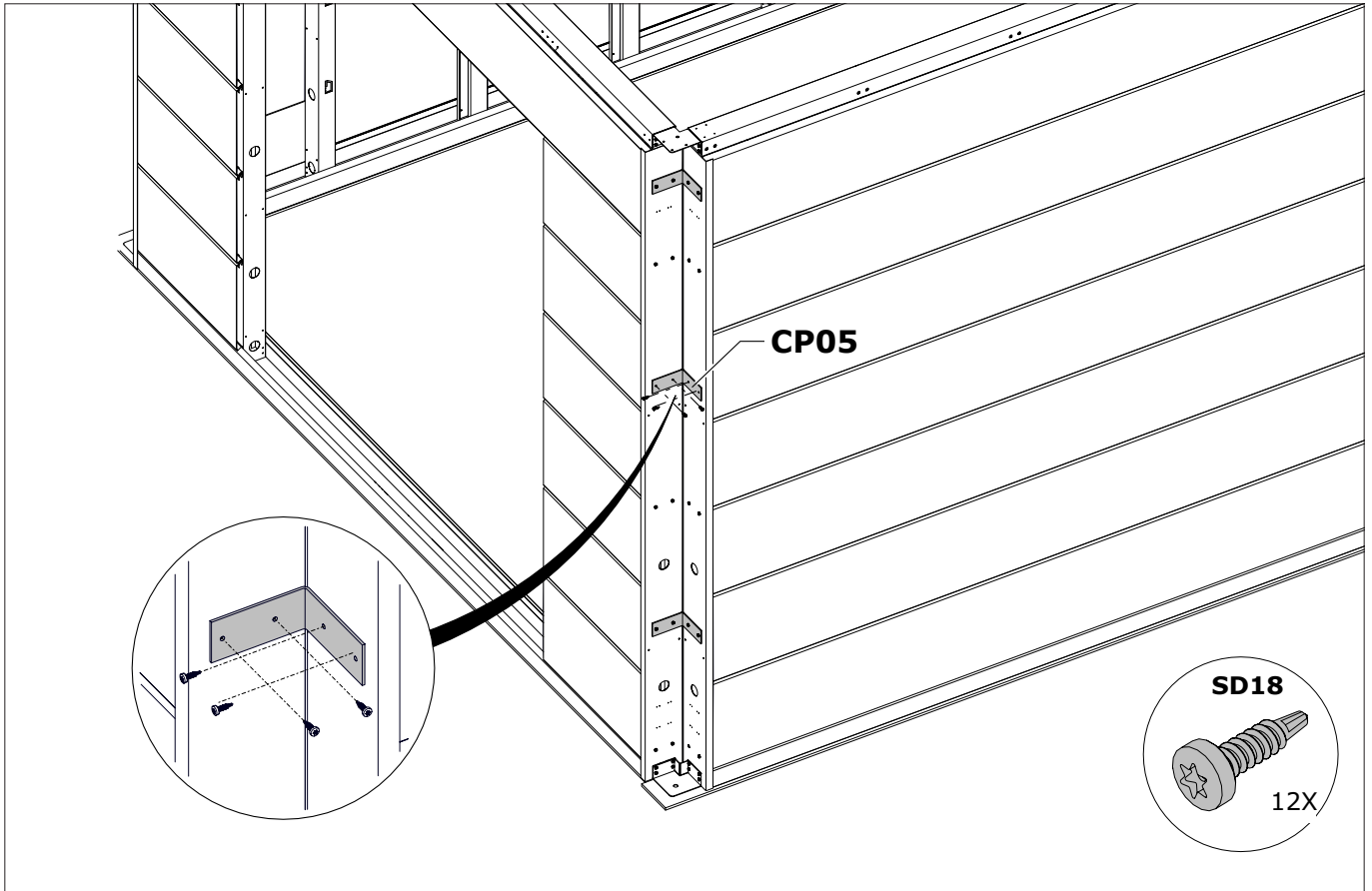

A/B Paroi / Wand / Wall / Wand

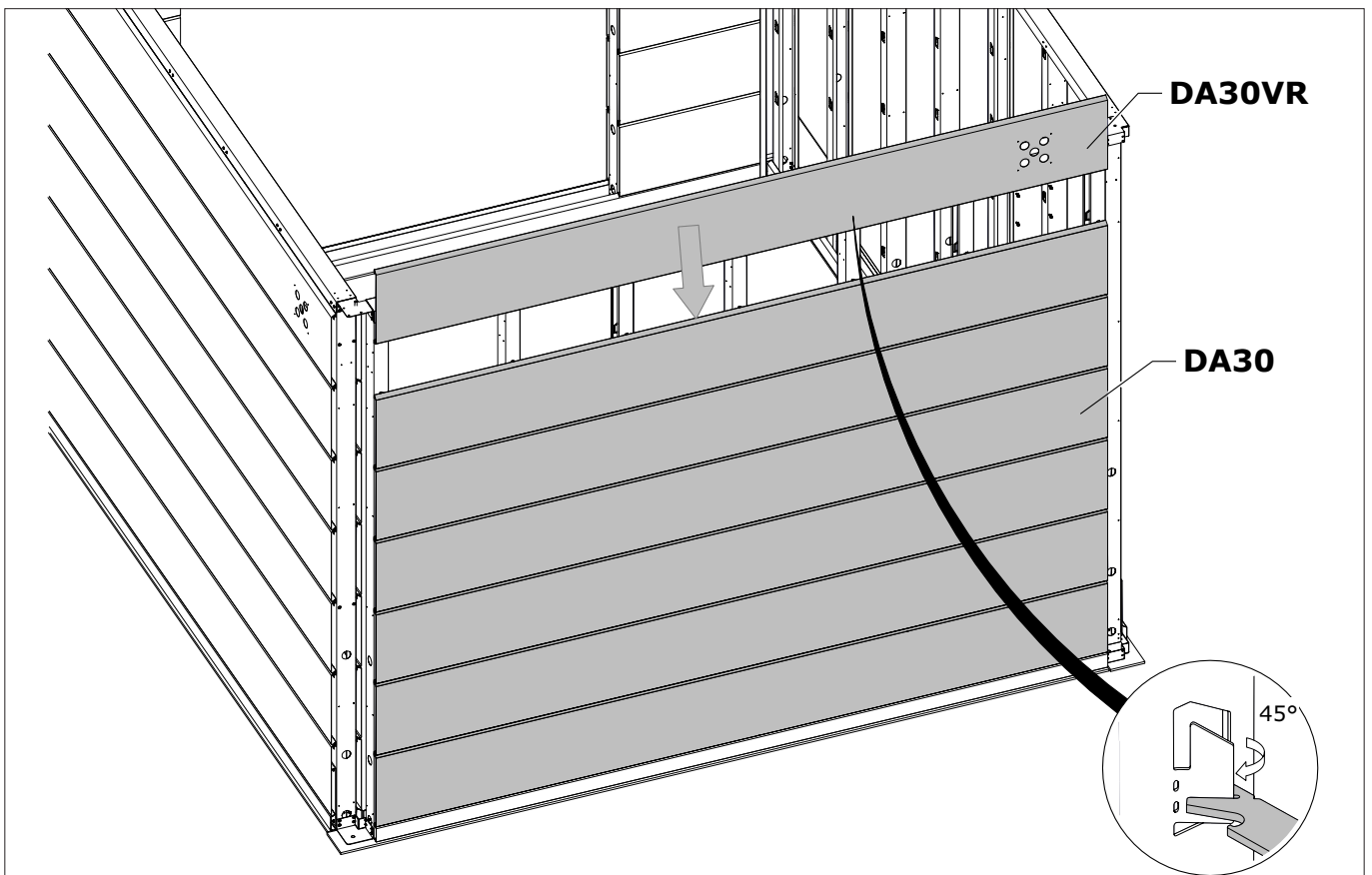

C Paroi / Wand / Wall / Wand

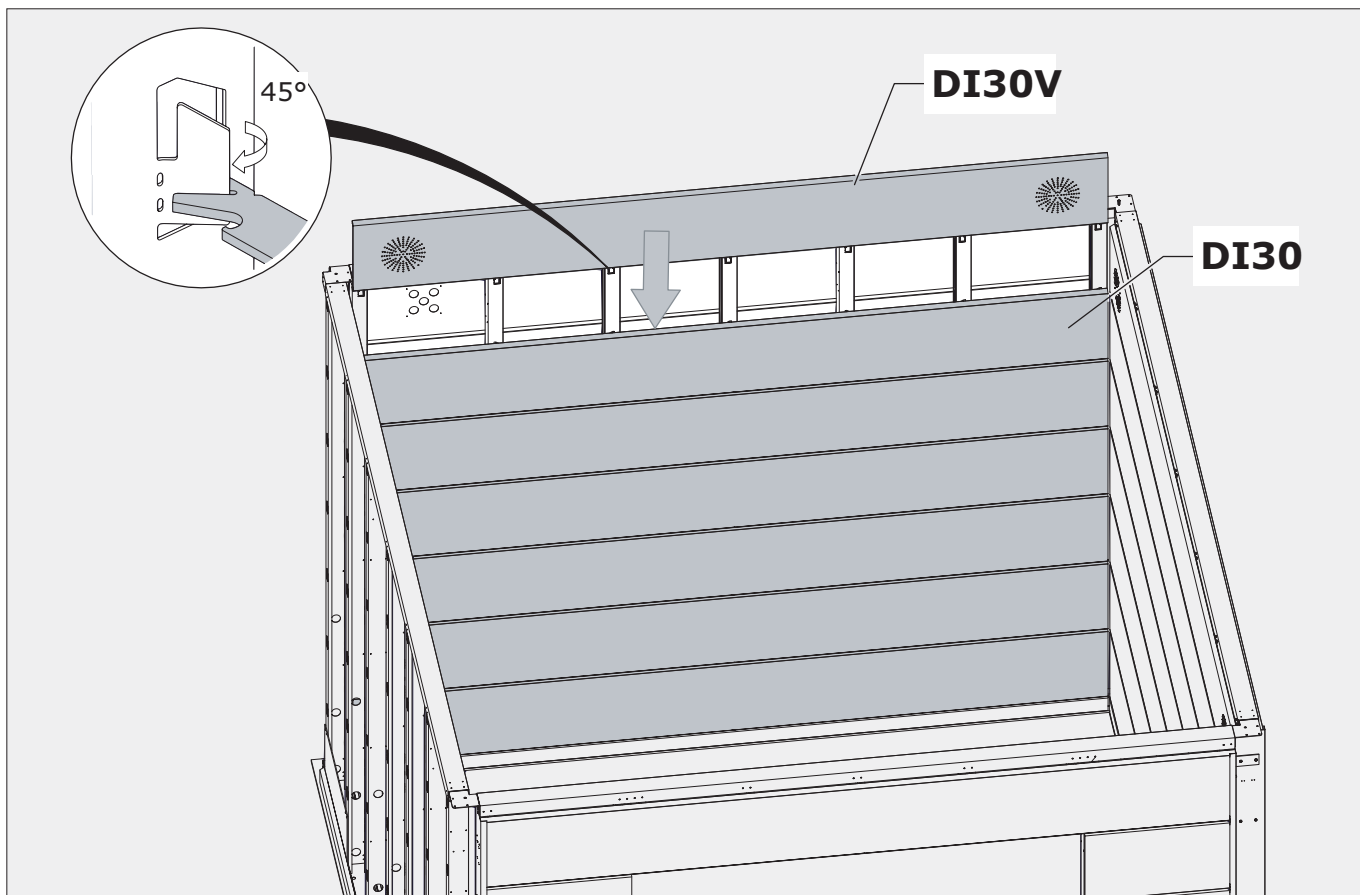

D Paroi / Wand / Wall / Wand Option / Optie / Option / Option

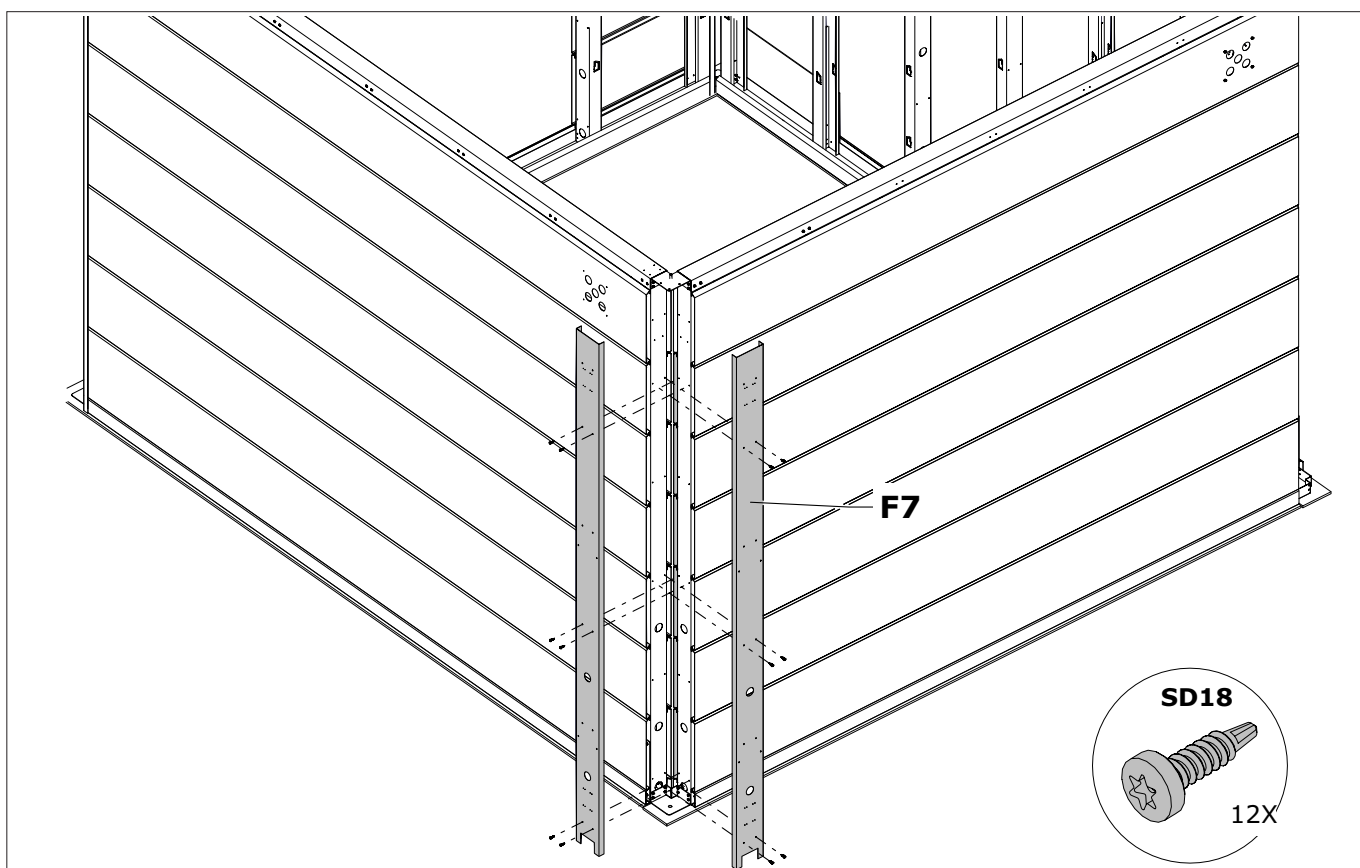

B/C Paroi / Wand / Wall / Wand

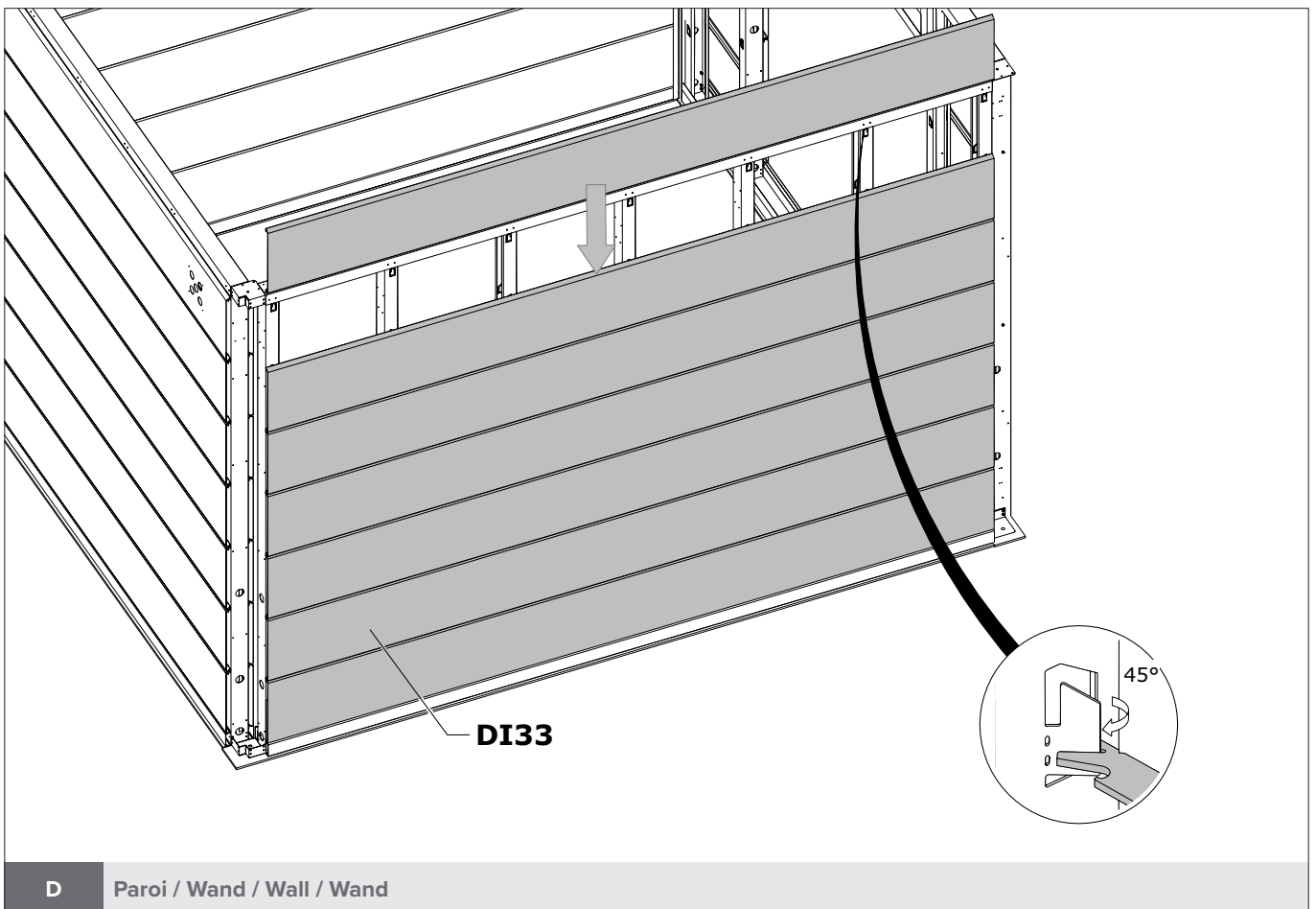
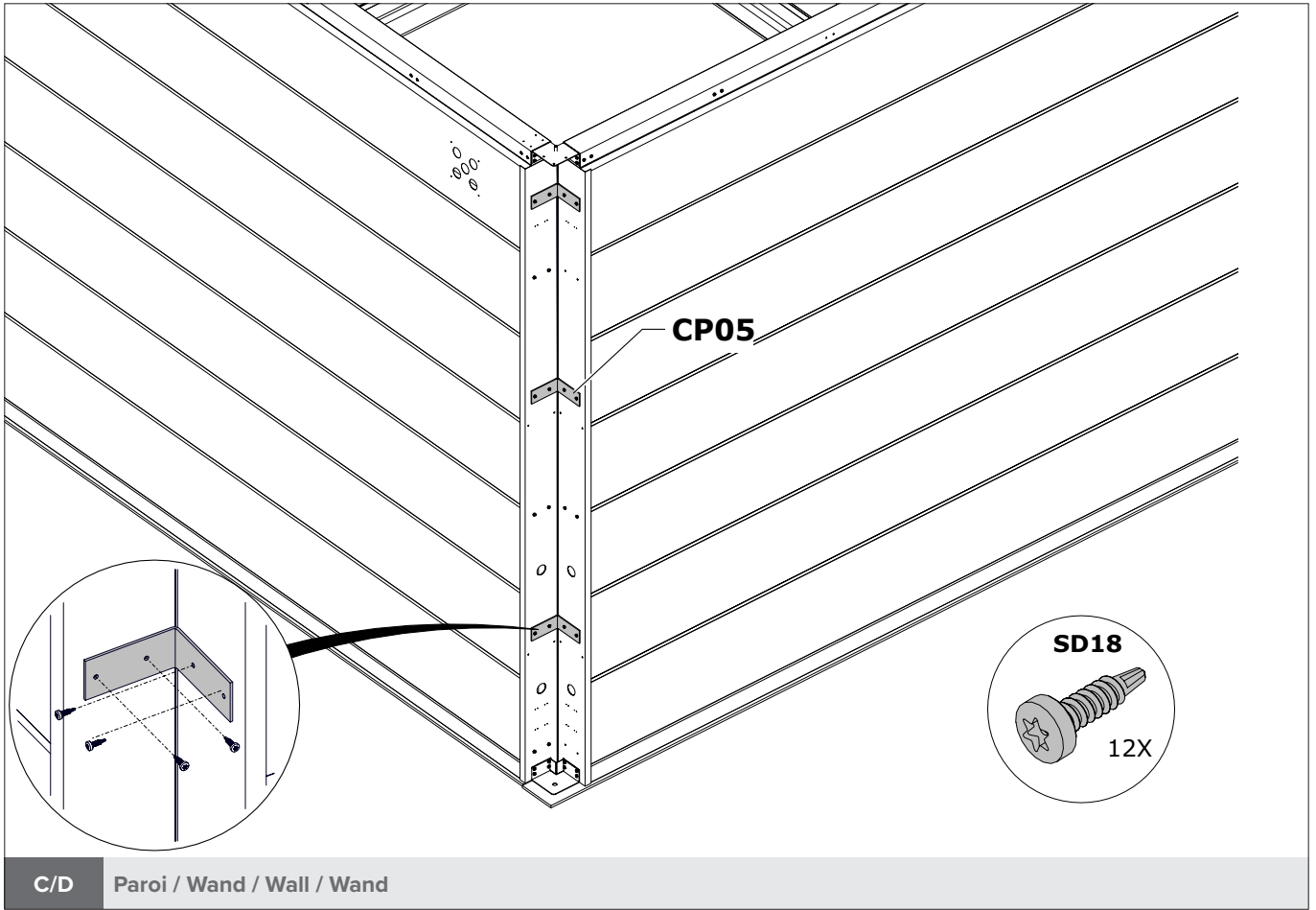

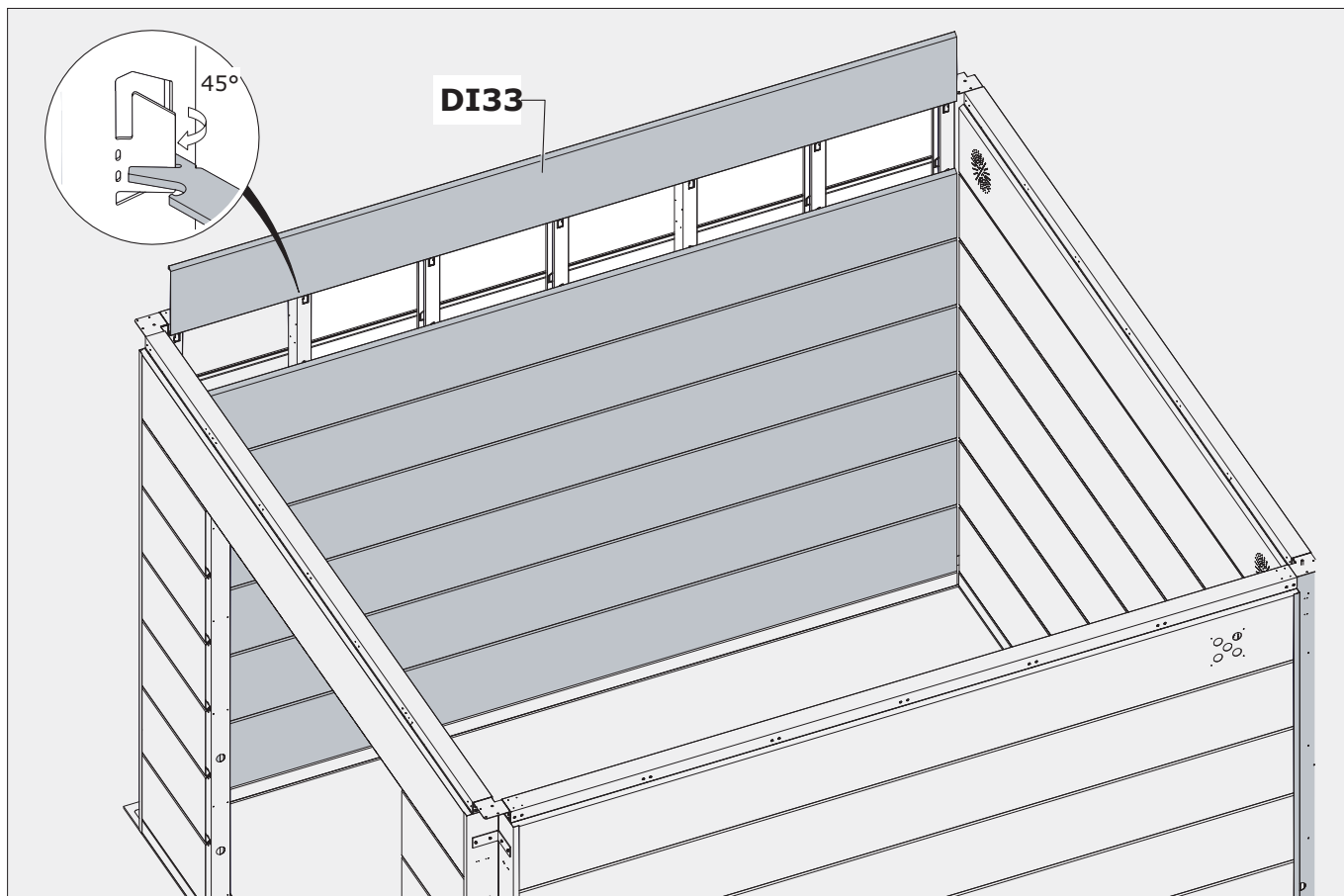

D Paroi / Wand / Wall / Wand

Option / Optie / Option / Option

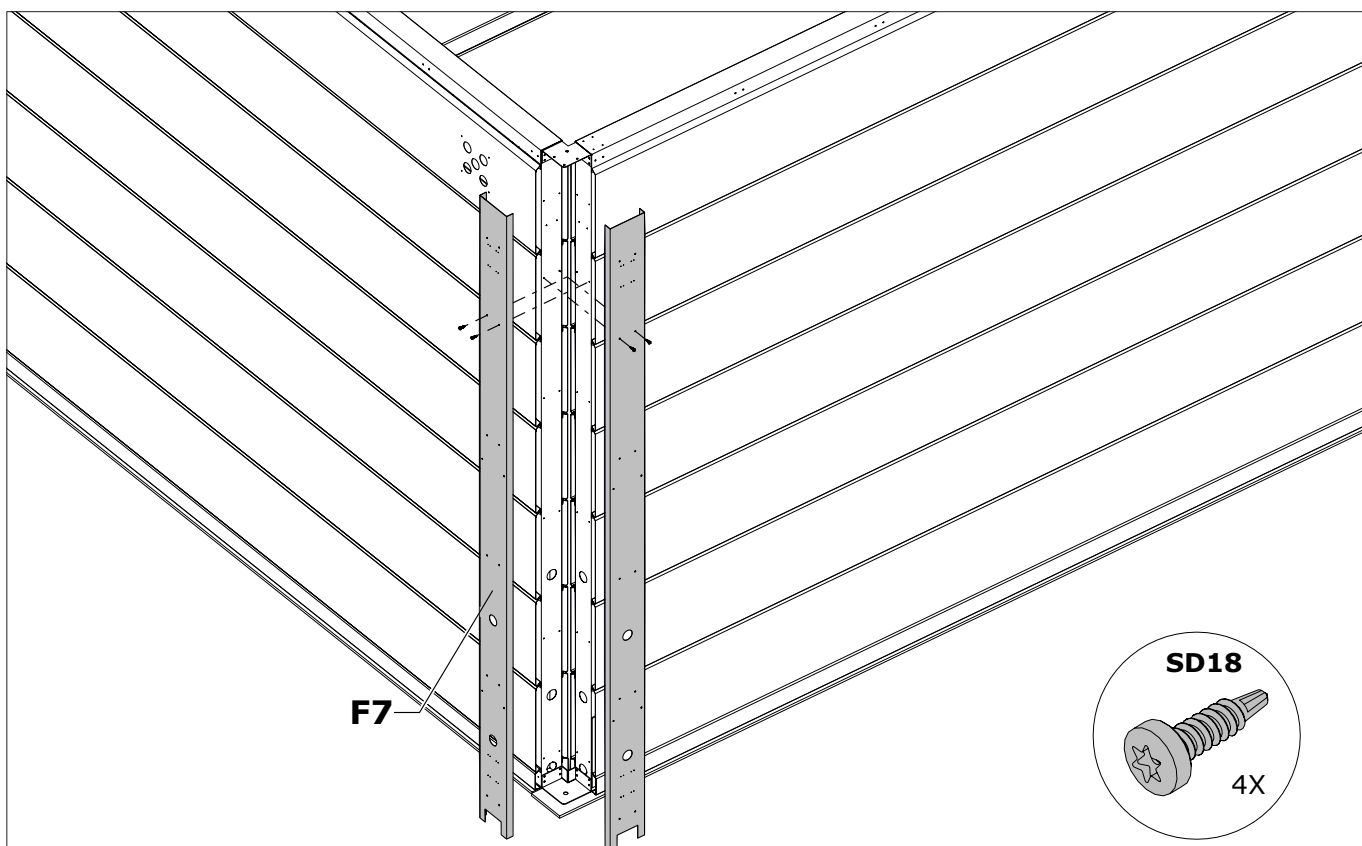

C/D Paroi / Wand / Wall / Wand

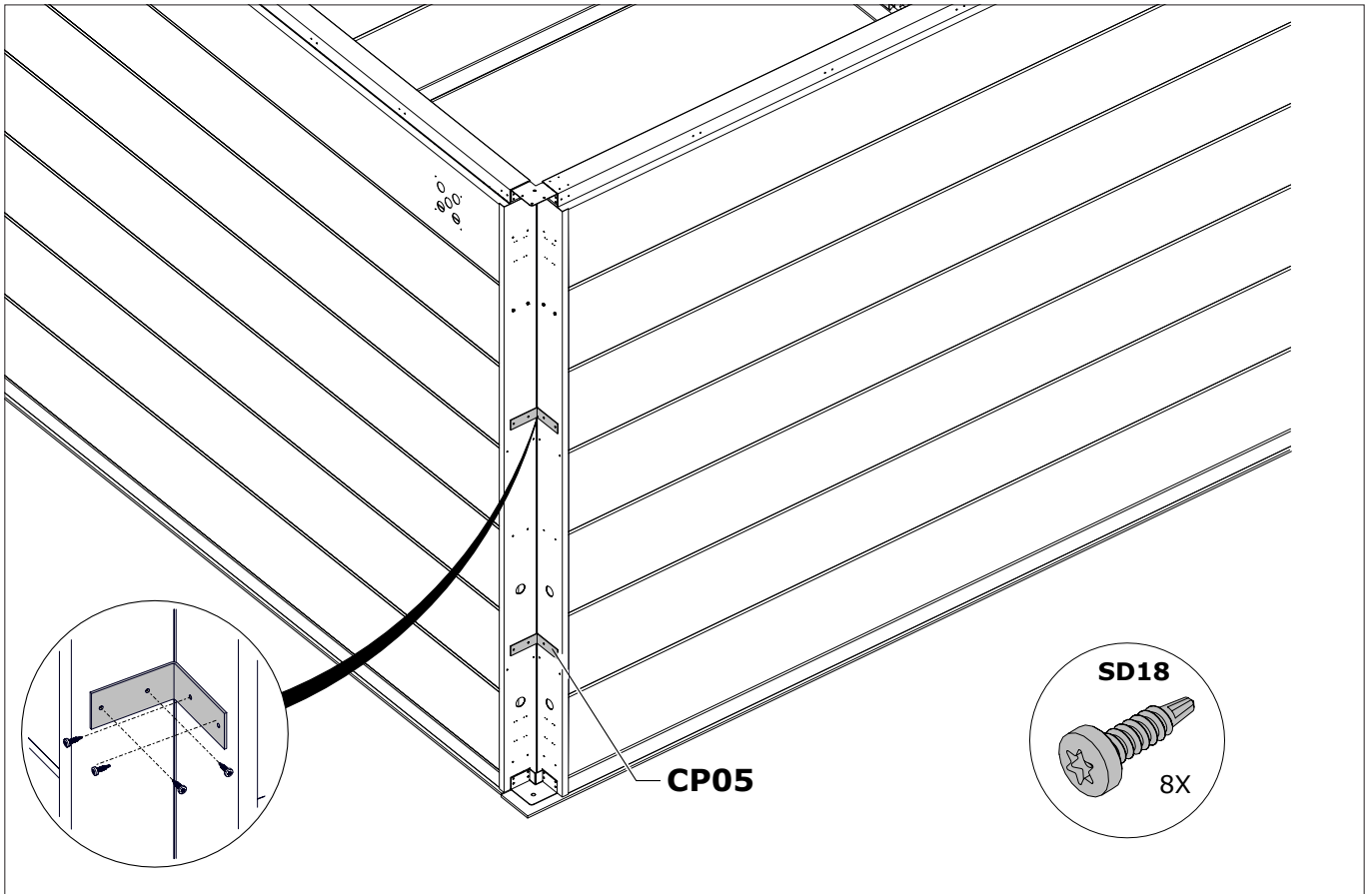

C Paroi / Wand / Wall / Wand

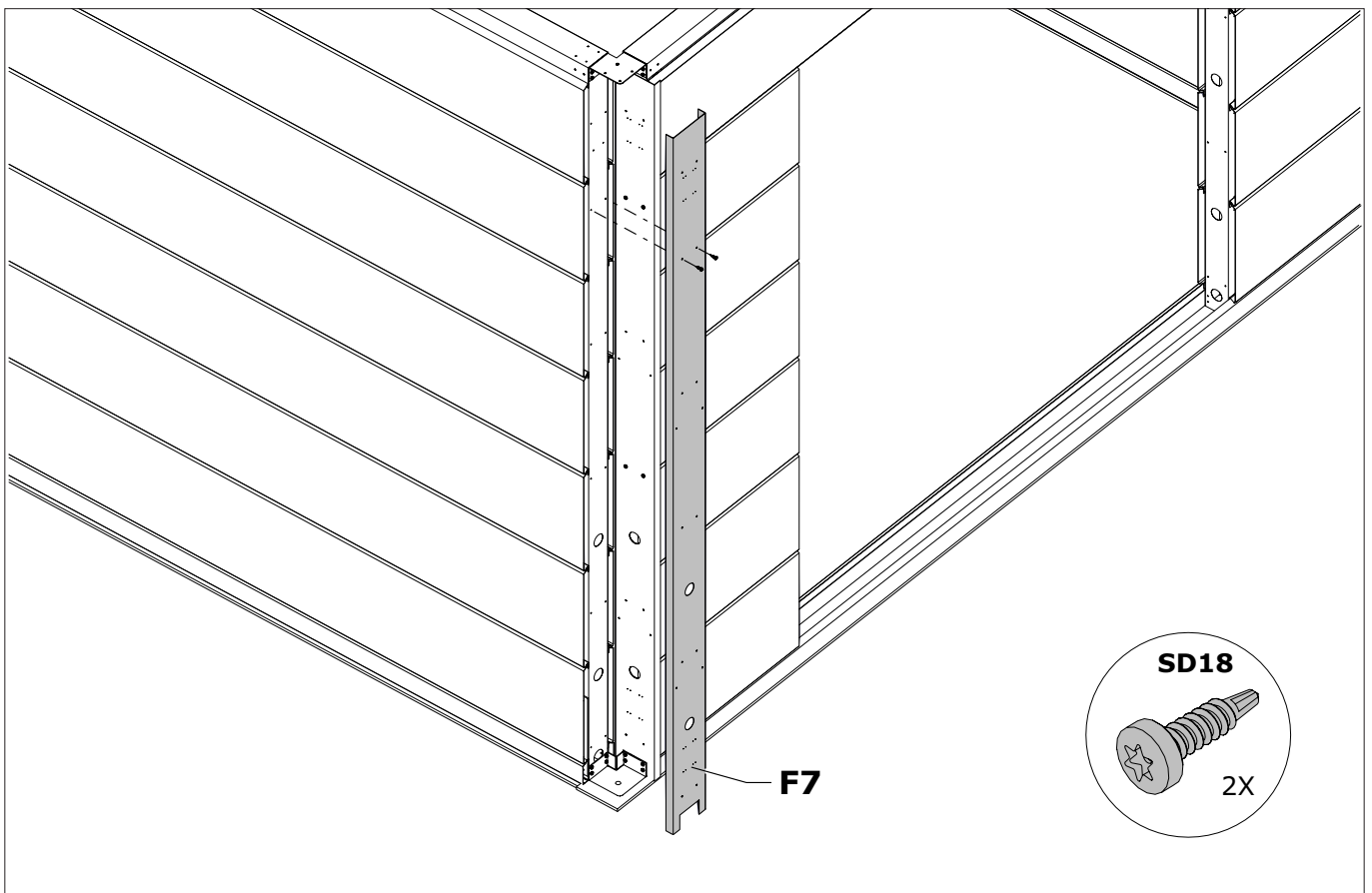

A Paroi / Wand / Wall / Wand

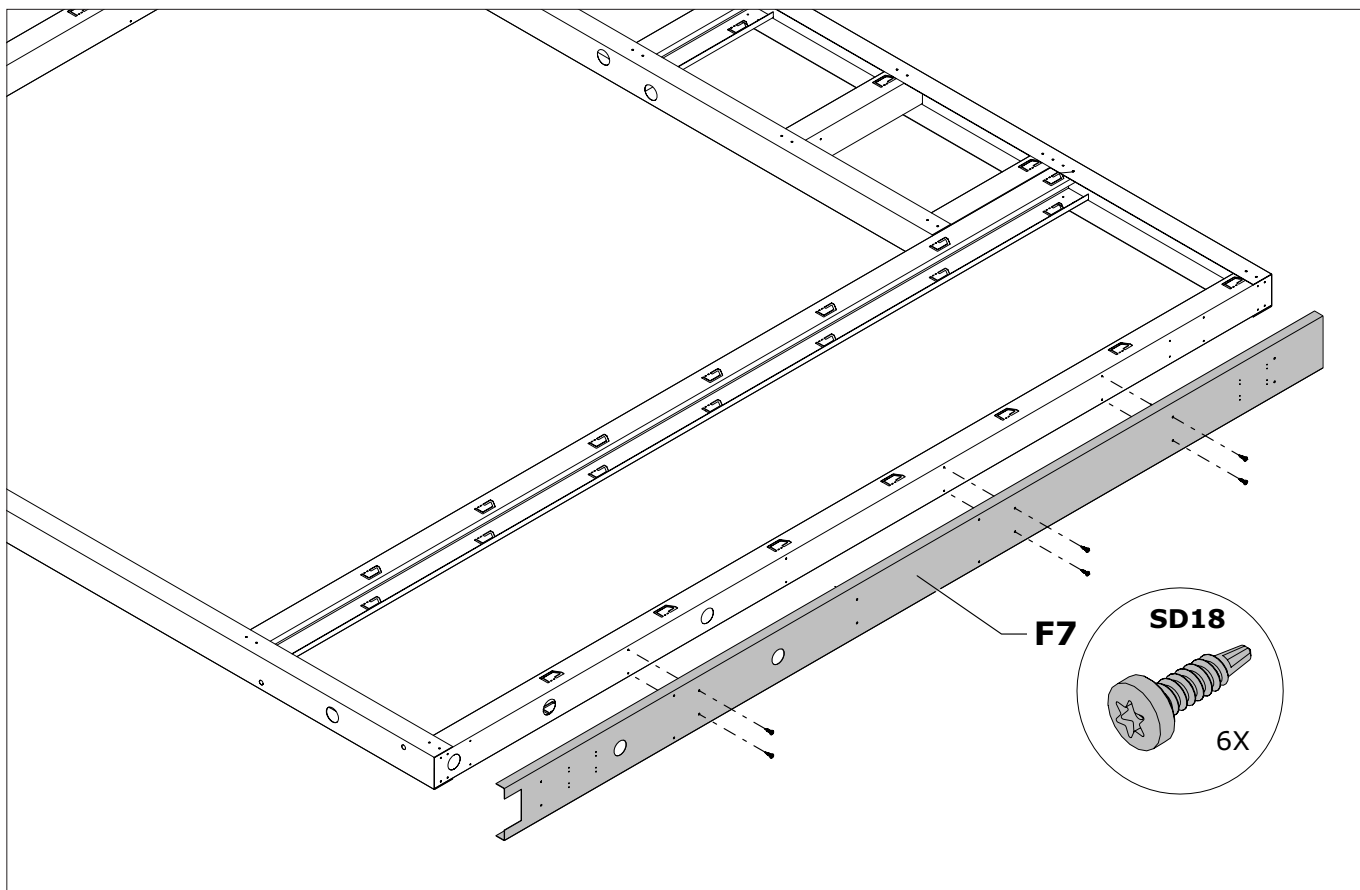

A

Paroi / Wand / Wall / Wand

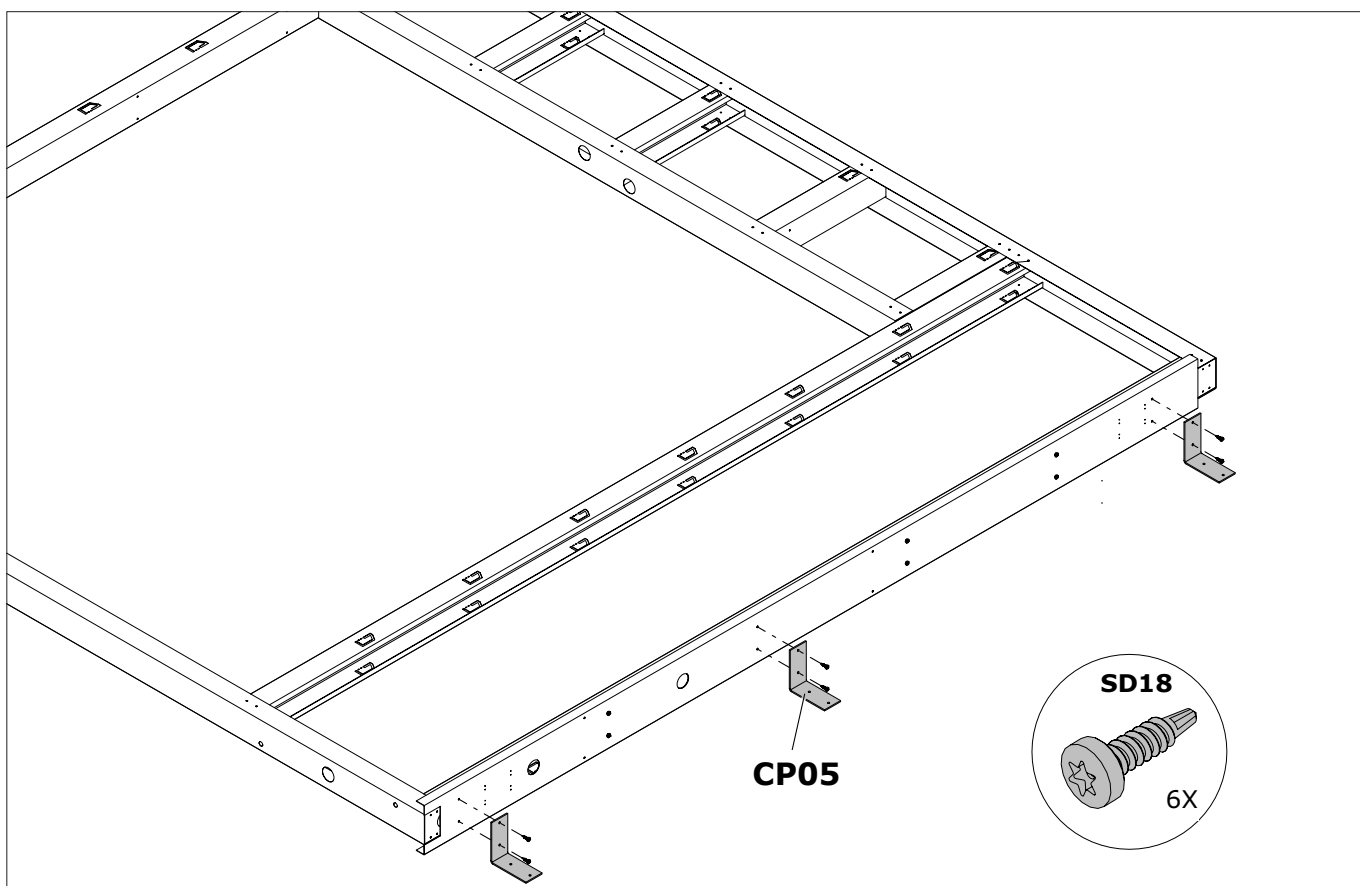

A

Paroi / Wand / Wall / Wand

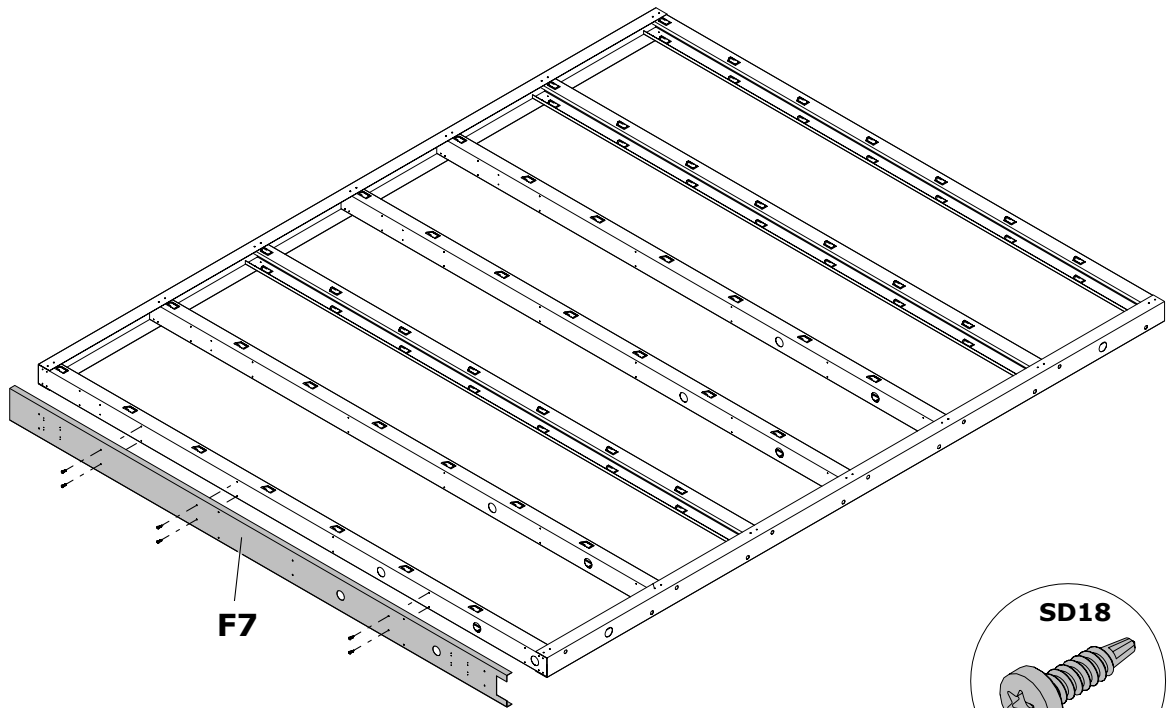

F7

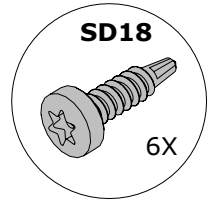

C2

Paroi / Wand / Wall / Wand

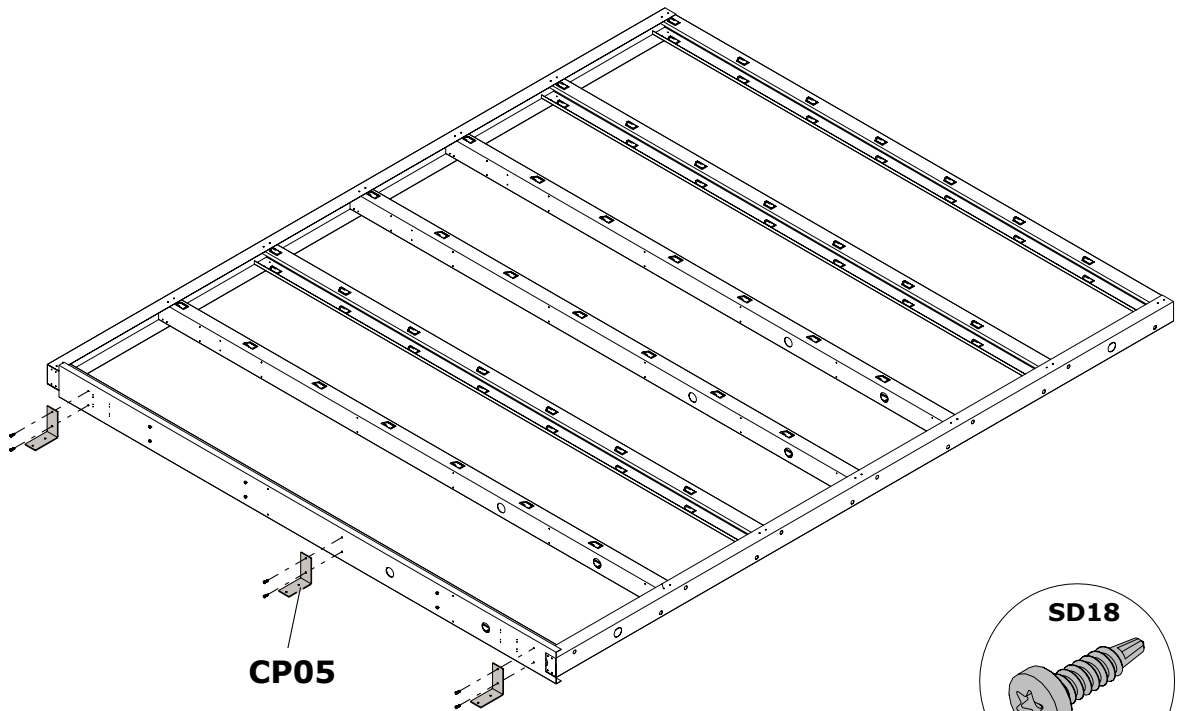

CP05

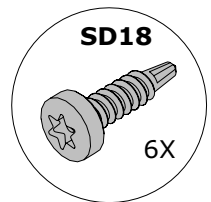

C2

Paroi / Wand / Wall / Wand

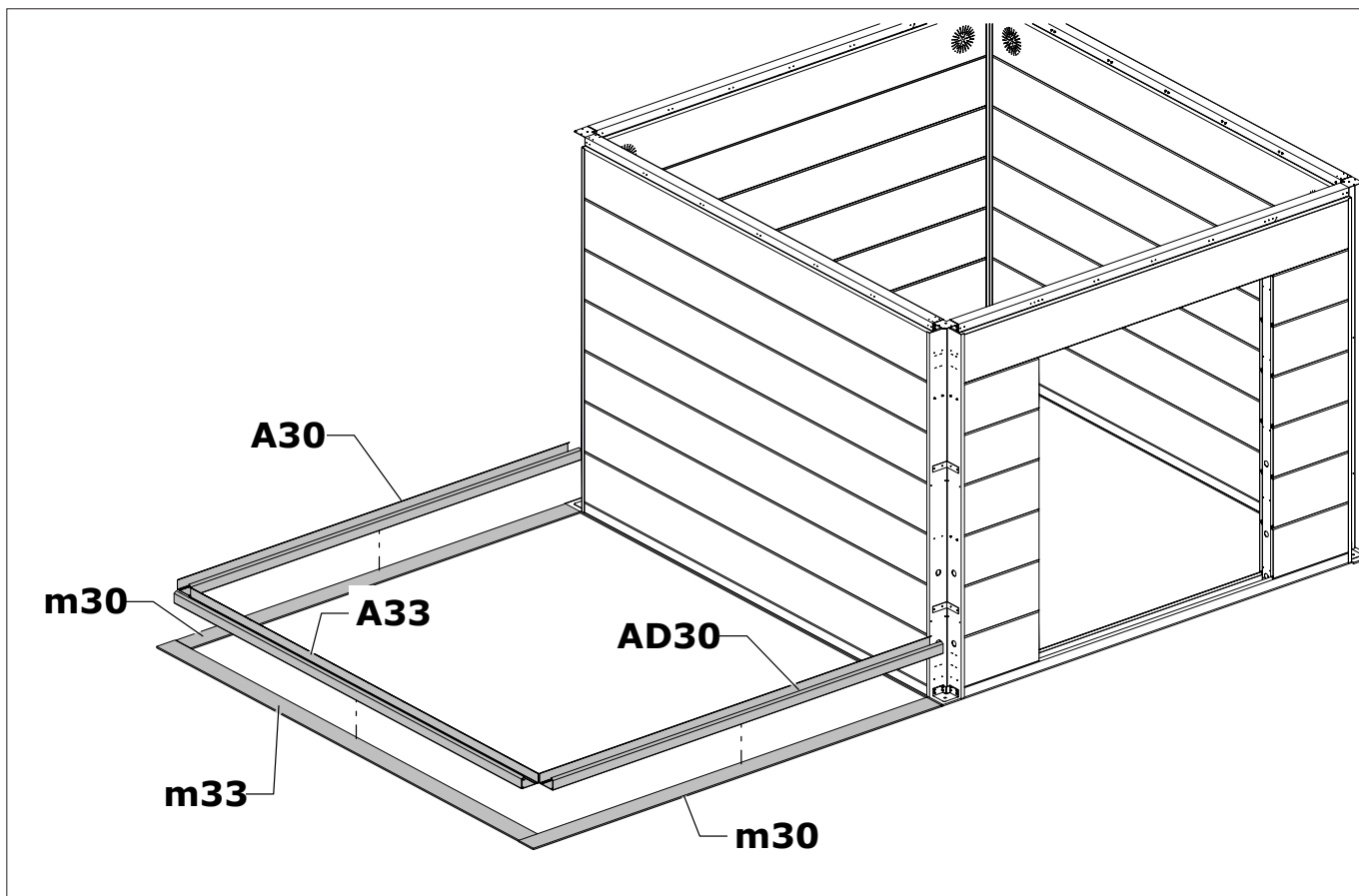

B1/B2/CD1 Paroi / Wand / Wall / Wand

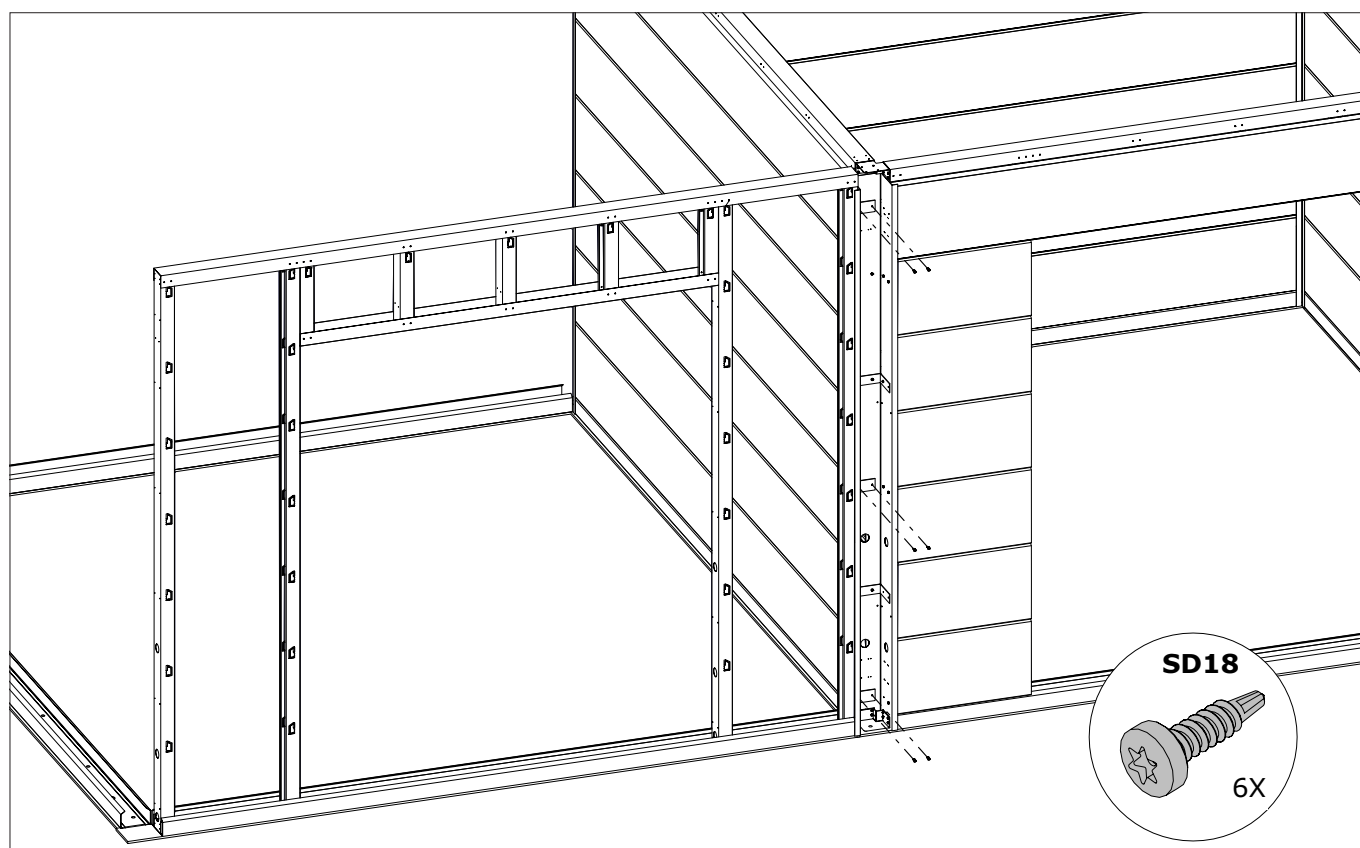

A2 Paroi / Wand / Wall / Wand

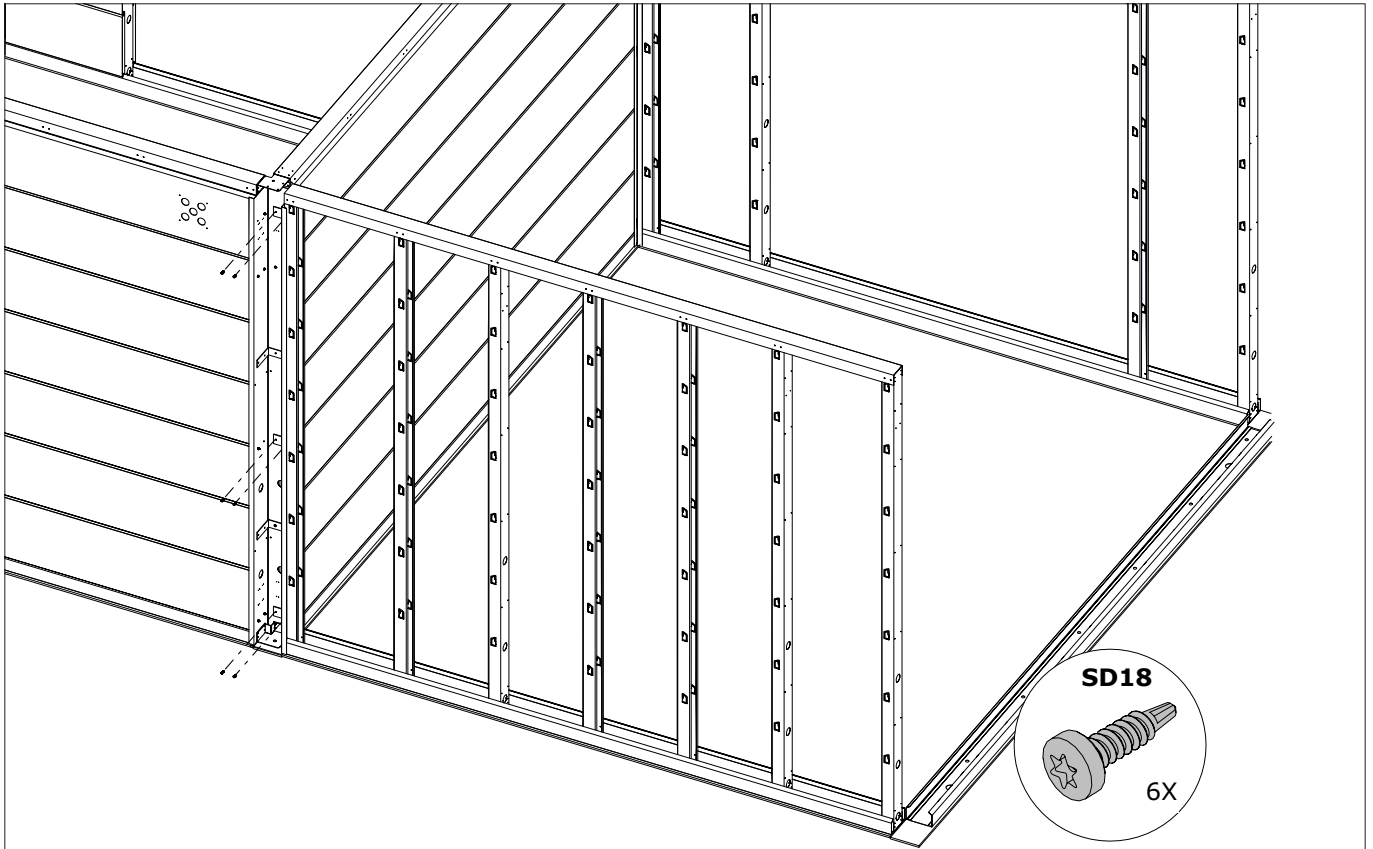

C2 Paroi / Wand / Wall / Wand

POW

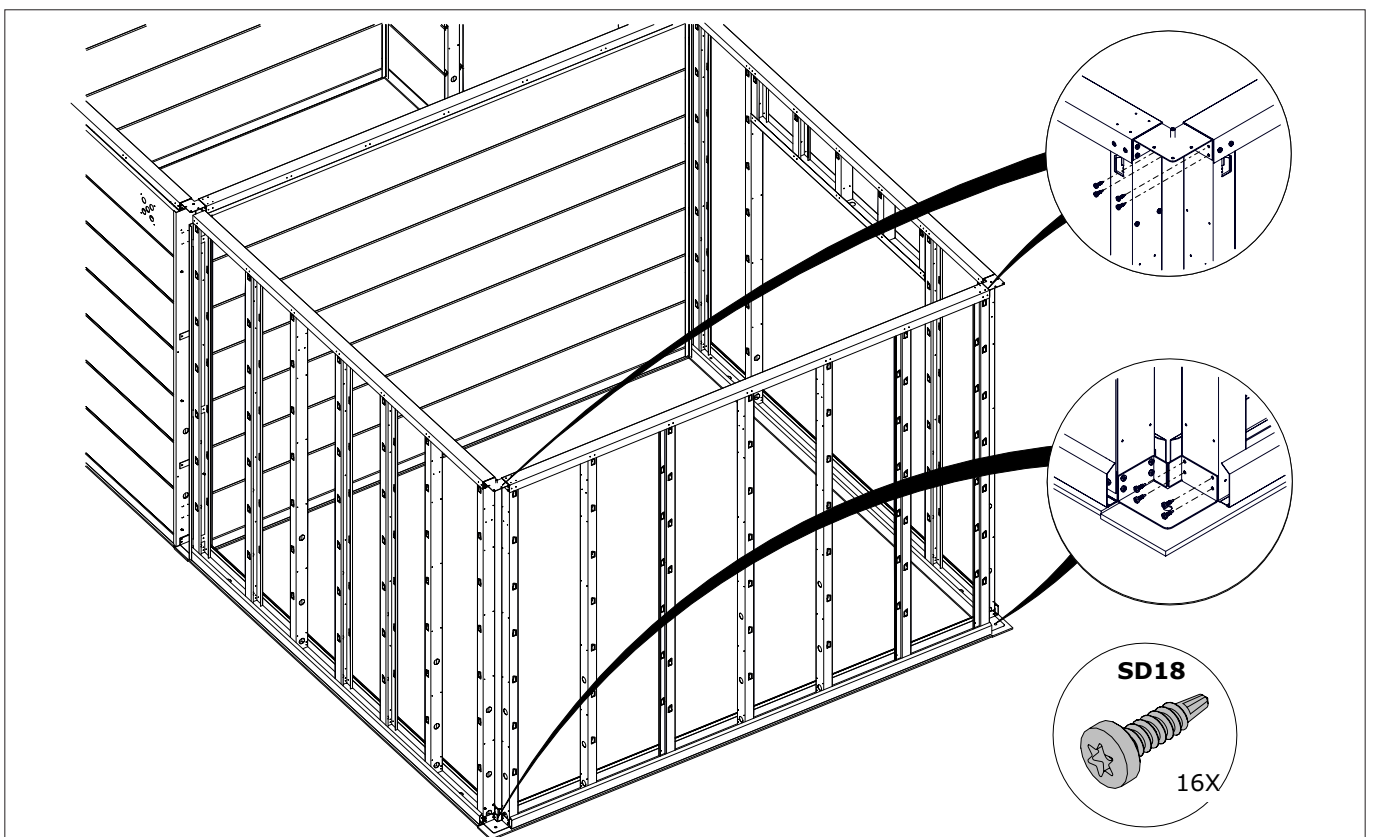

Paroi / Wand / Wall / Wand

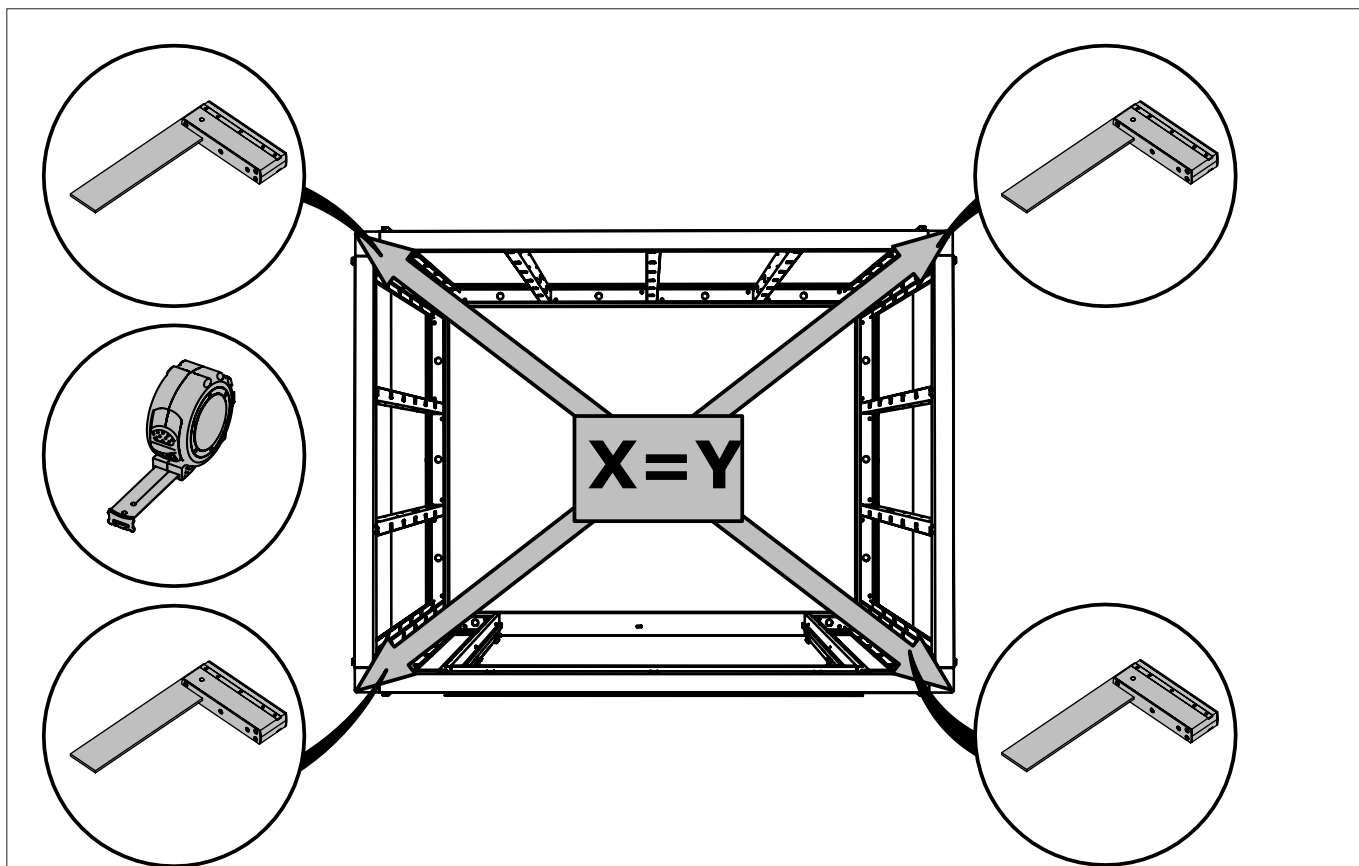

Ancrage / Verankering / Anchoring / Verankerung

POW

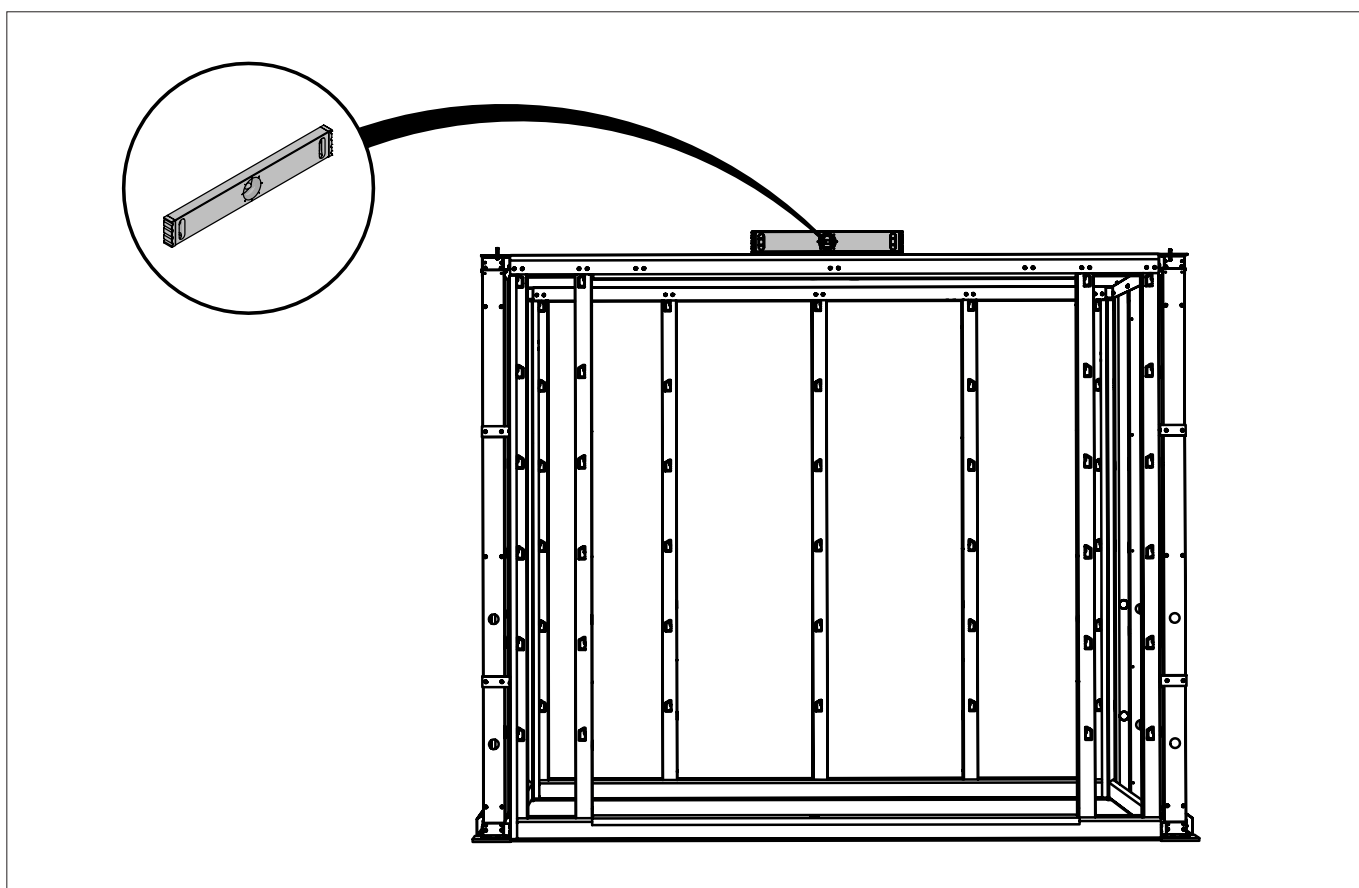

Ancrage / Verankering / Anchoring / Verankerung

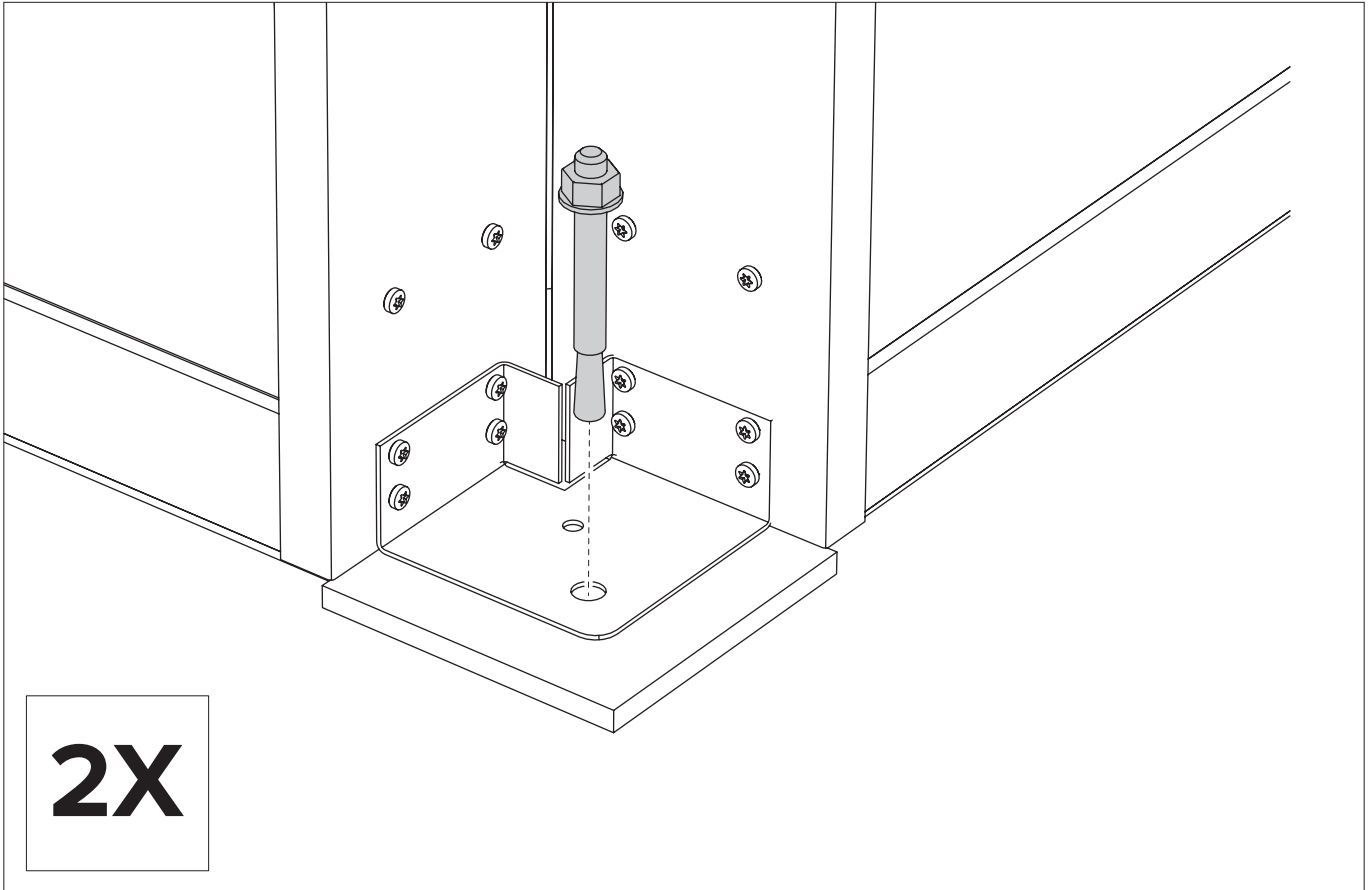

B1/B2/CD1/D2 Anchrage / Verankering / Anchoring / Verankerung

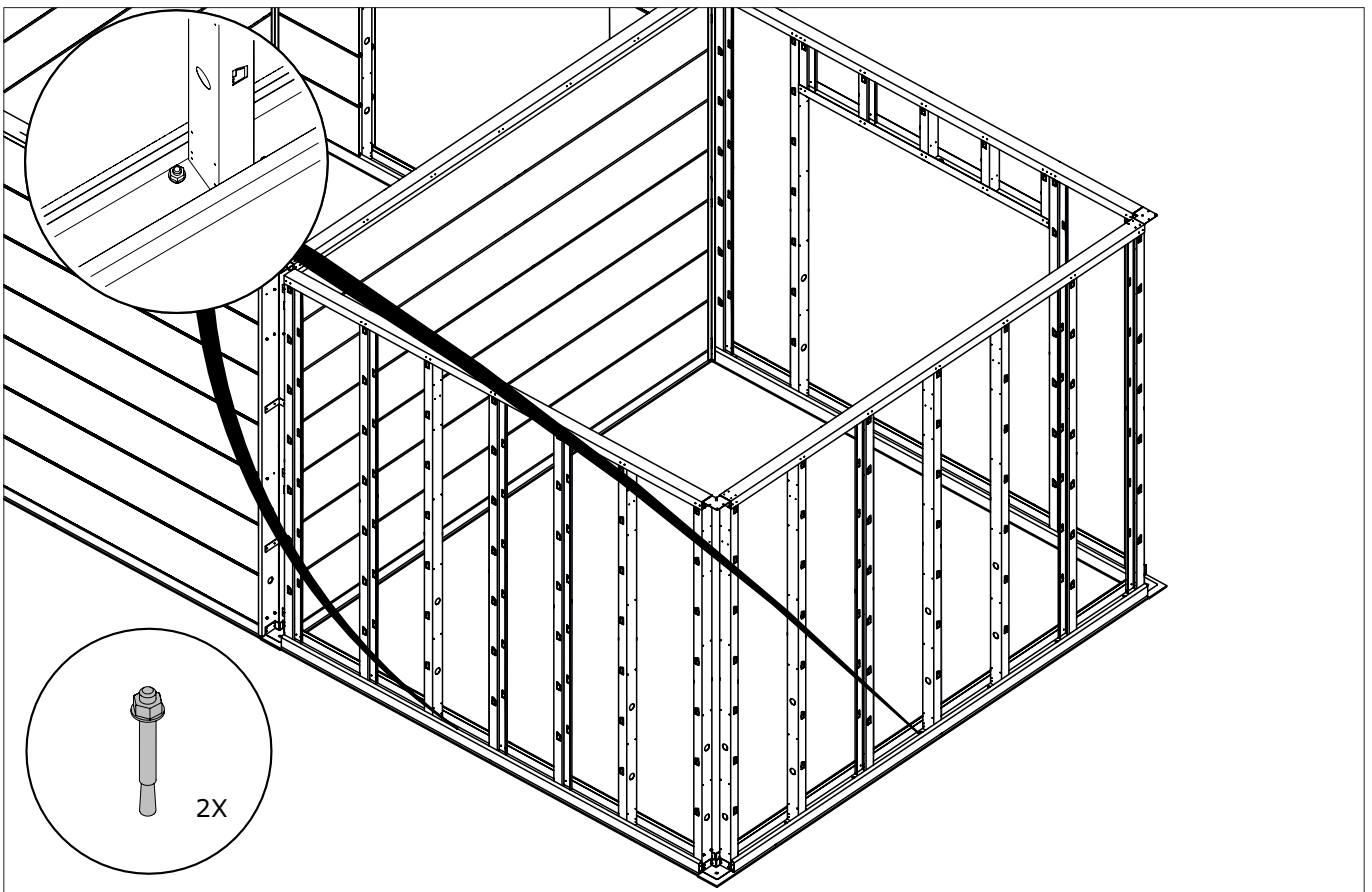

B1/B2/CD1/D2 Anchrage / Verankering / Anchoring / Verankerung

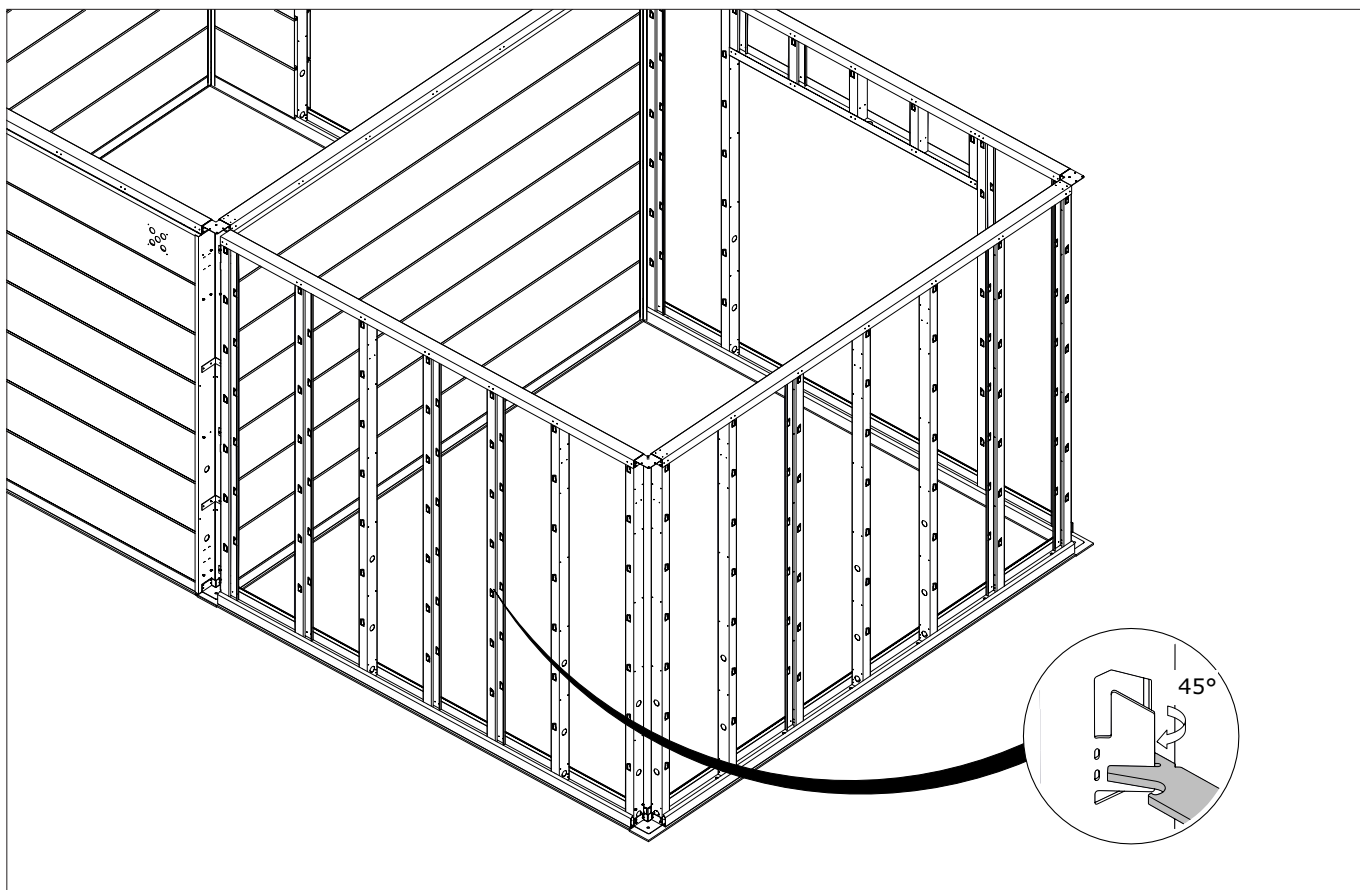

B1/B2/CD1/D2

Paroi / Wand / Wall / Wand

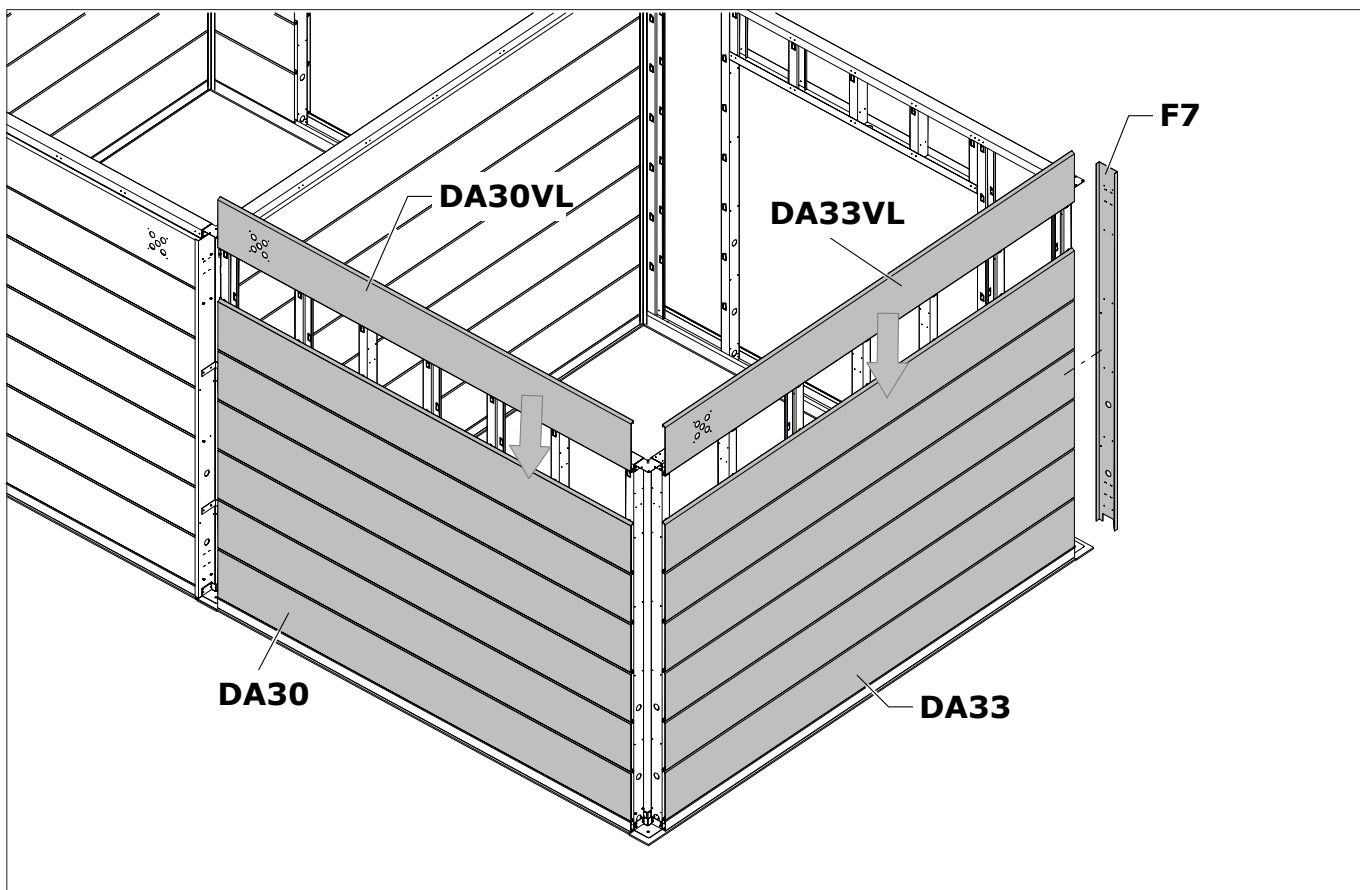

B1/B2/CD1/D2

Paroi / Wand / Wall / Wand

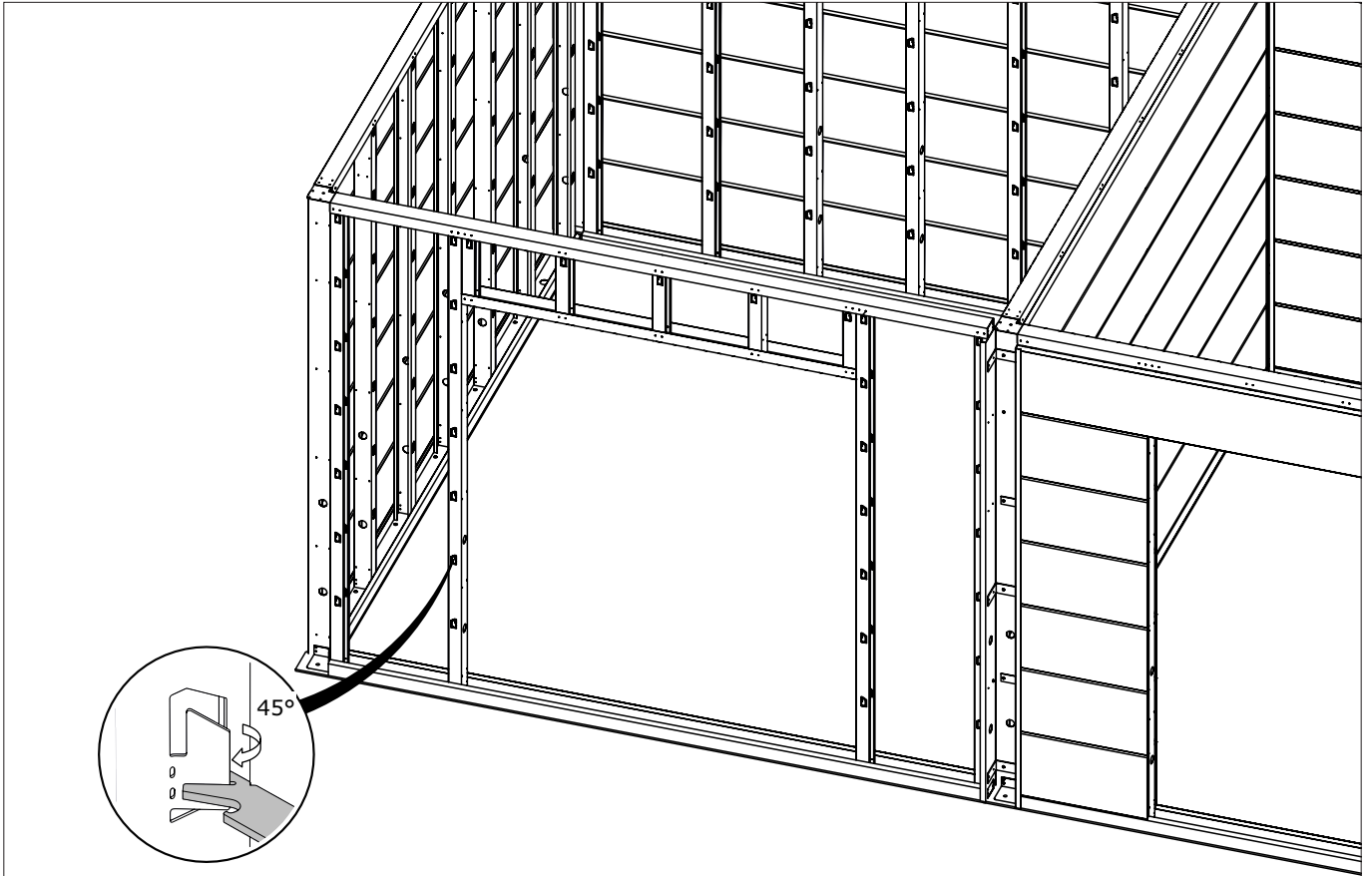

B1/B2/CD1/D2 Paroi / Wand / Wall / Wand

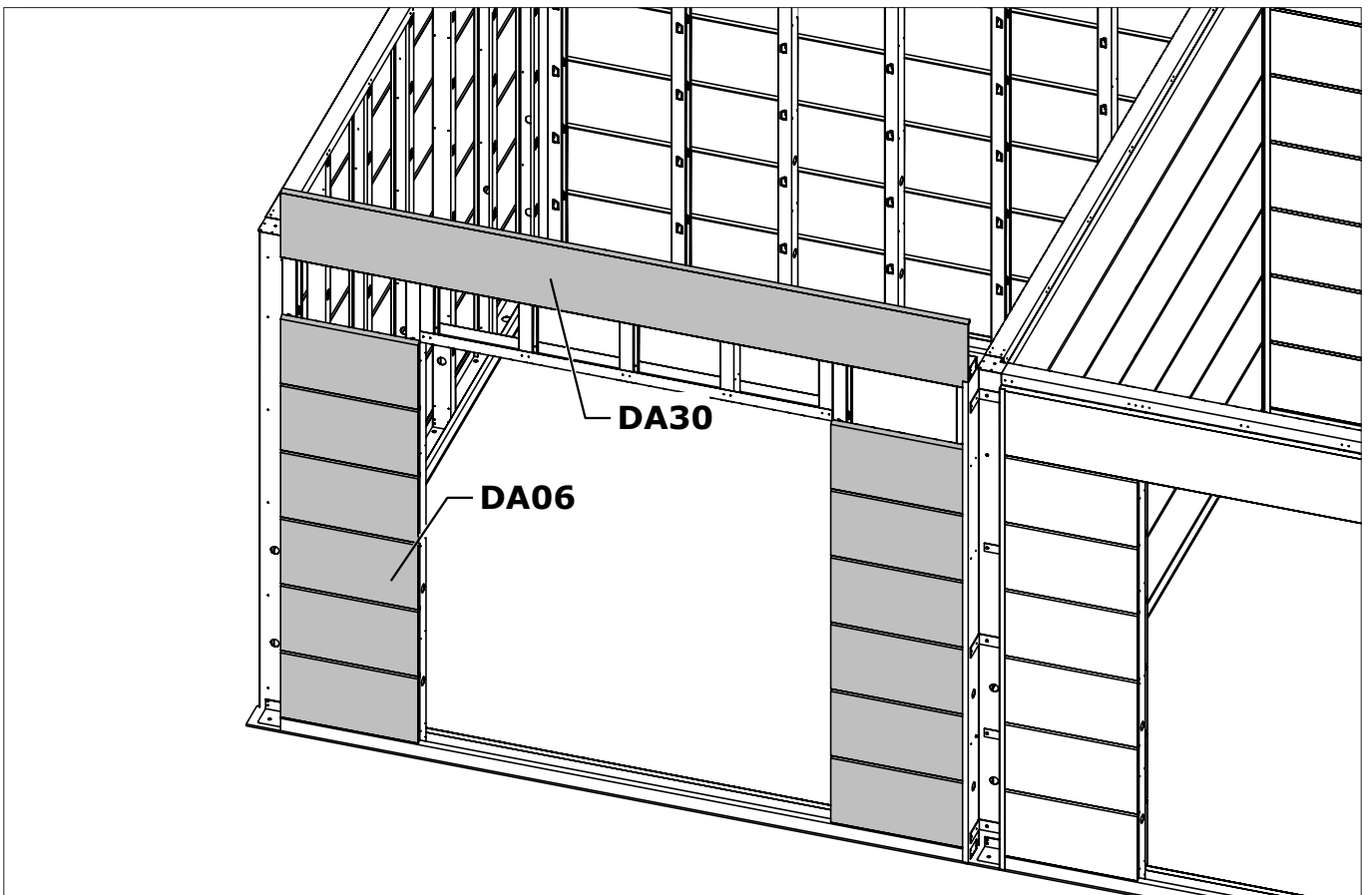

B1/B2/CD1/D2 Paroi / Wand / Wall / Wand

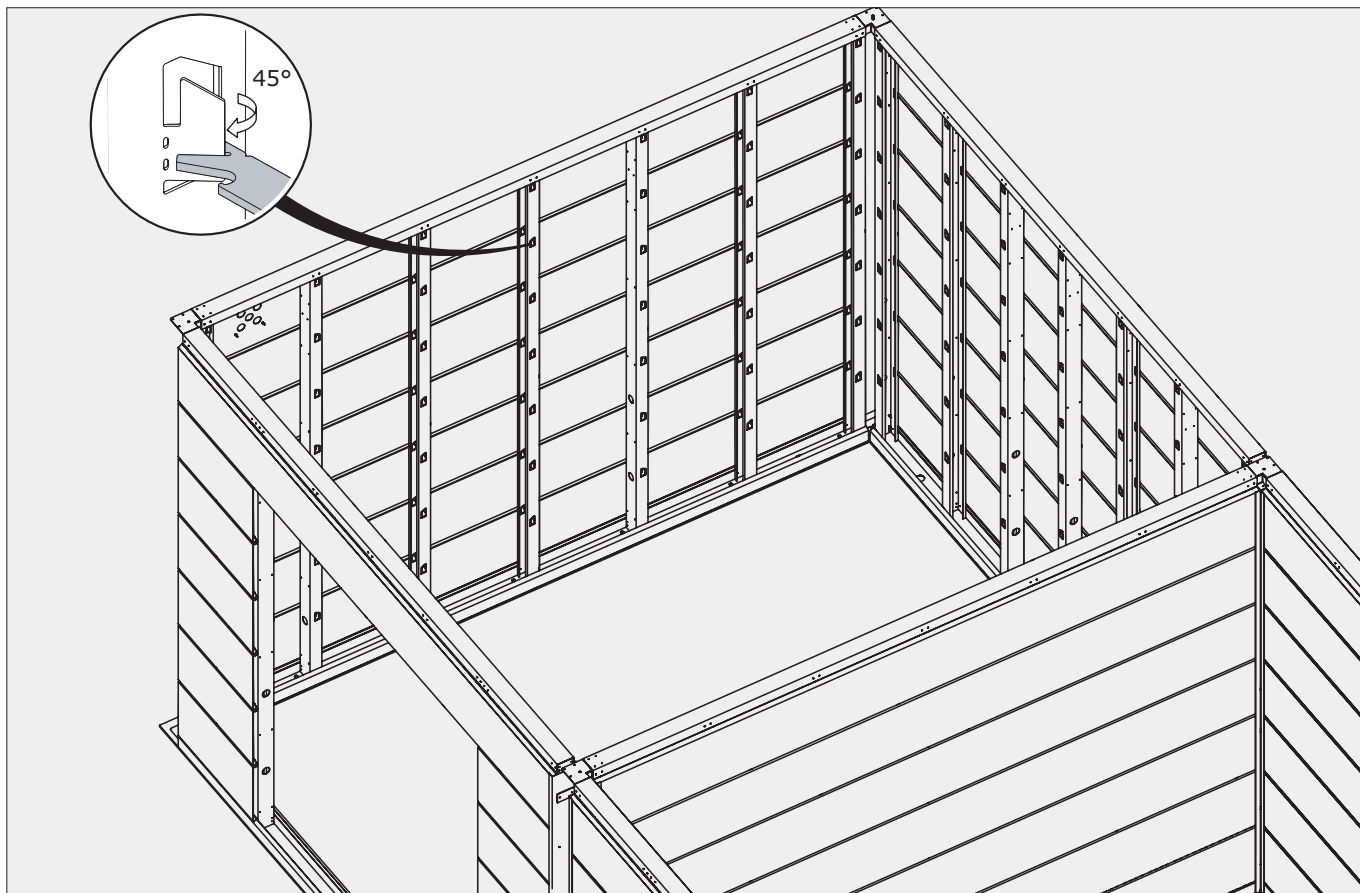

F Paroi / Wand / Wall / Wand

Option / Optie / Option / Option

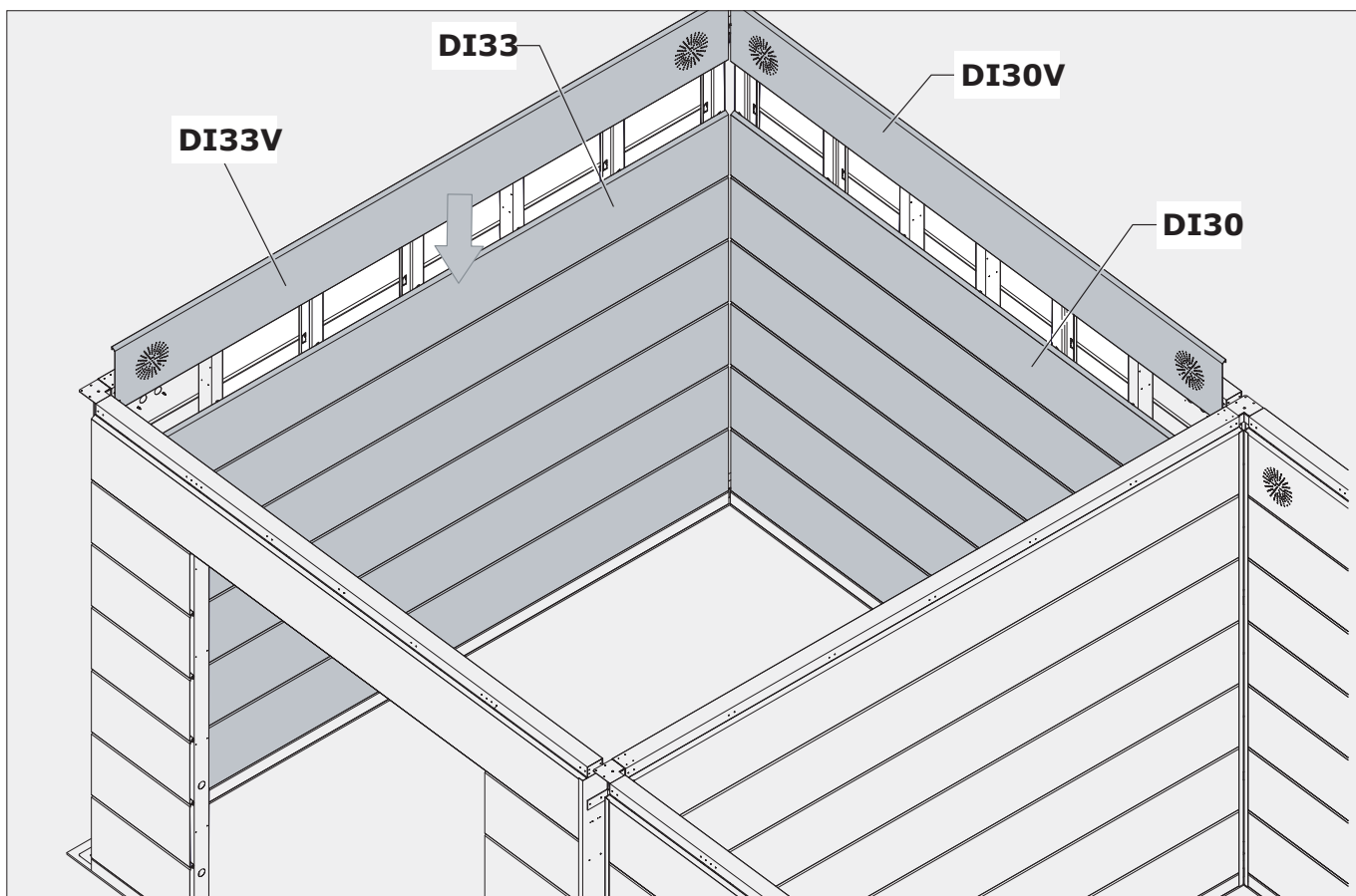

C+F Paroi / Wand / Wall / Wand

Option / Optie / Option / Option

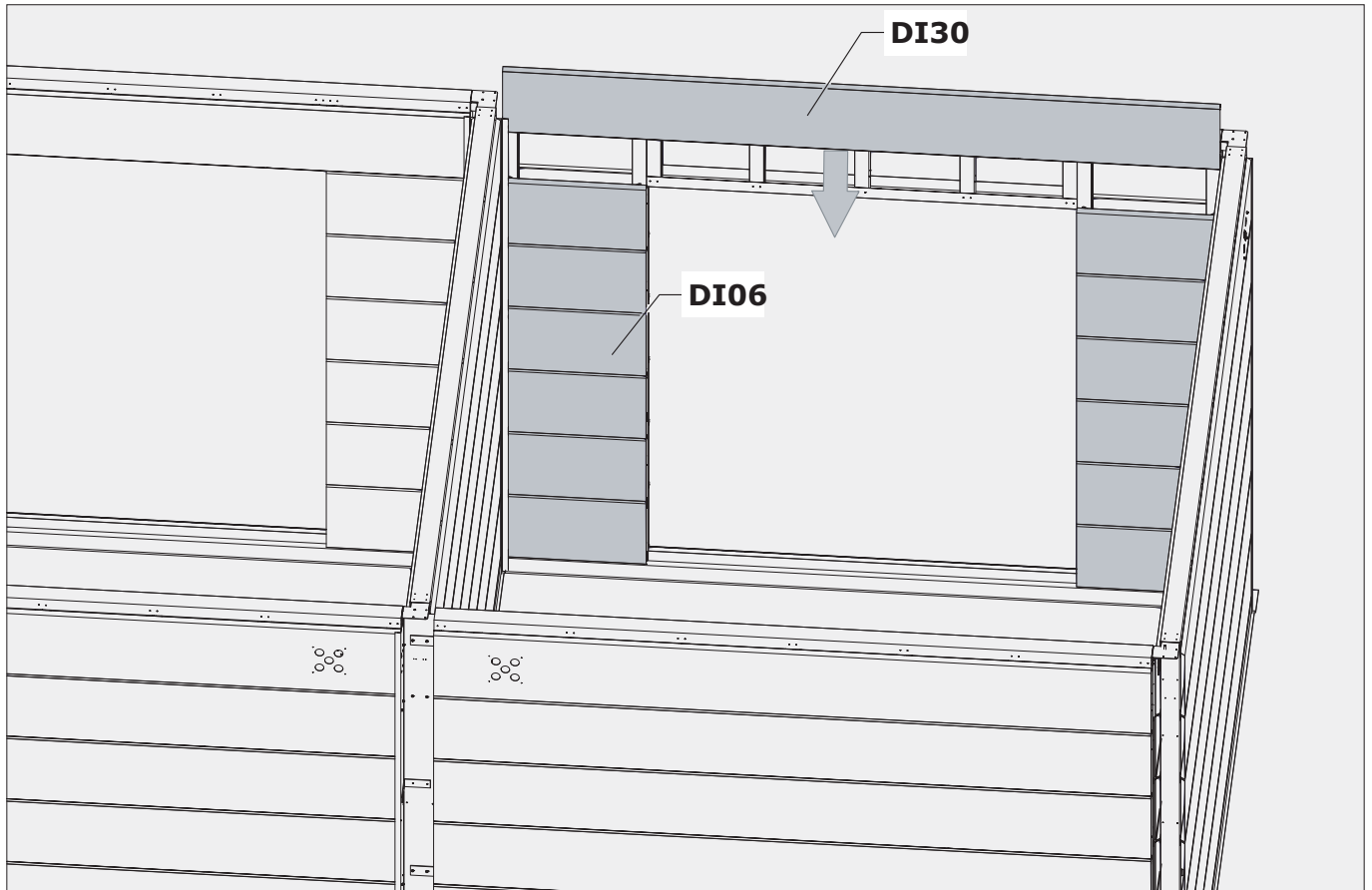

A

Paroi / Wand / Wall / Wand

Option / Optie / Option / Option

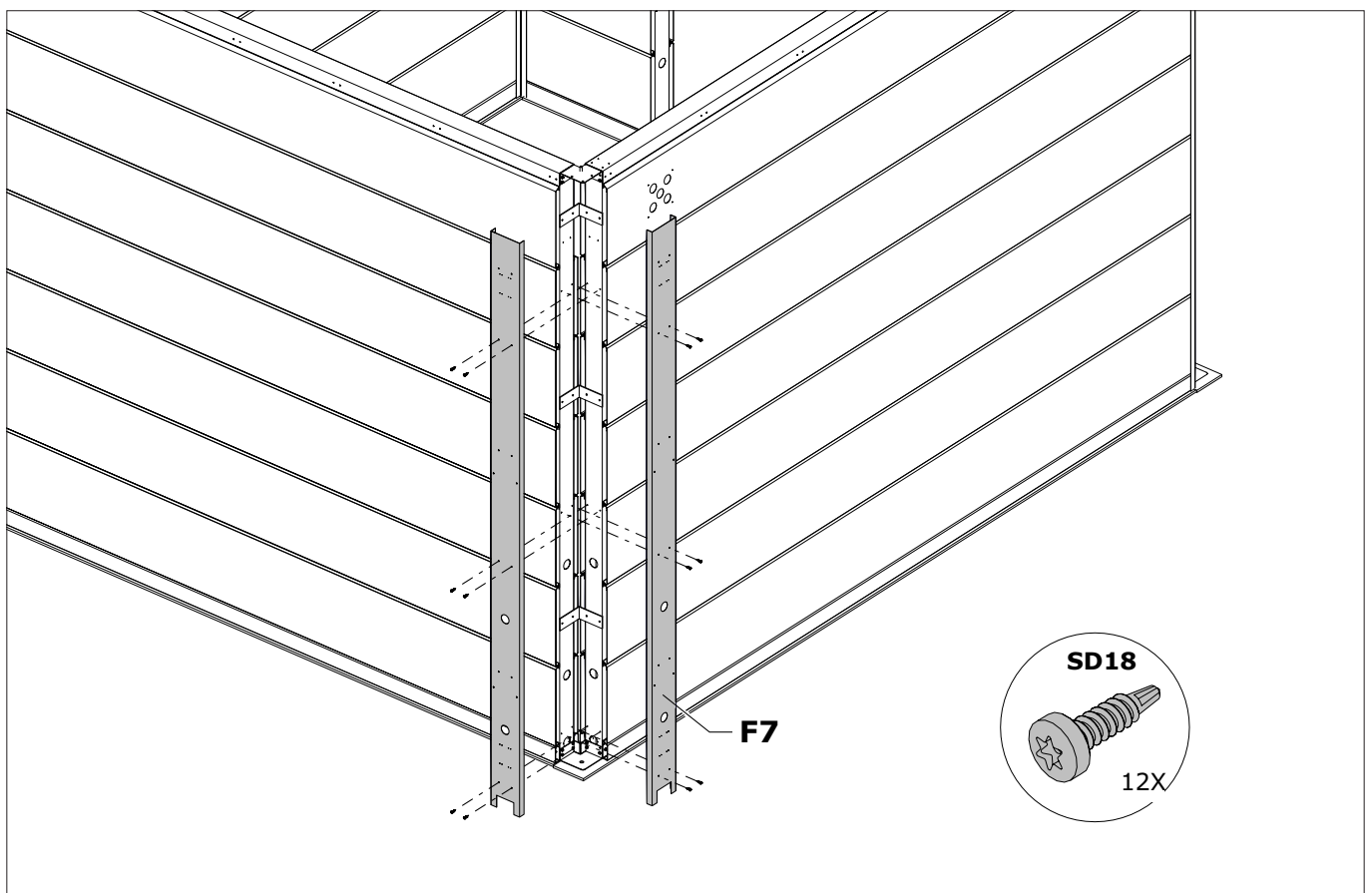

F

Paroi / Wand / Wall / Wand

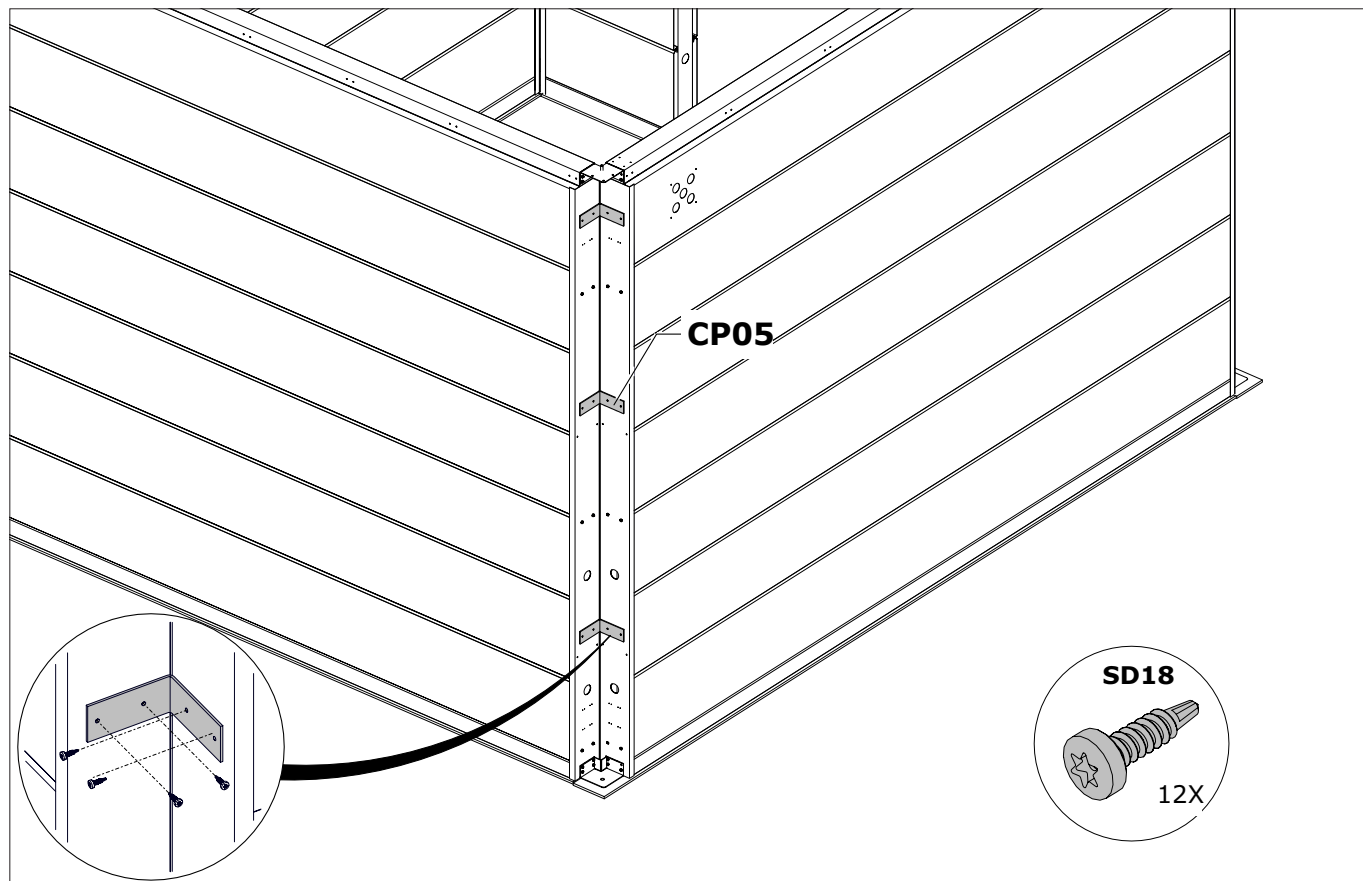

C Paroi / Wand / Wall / Wand

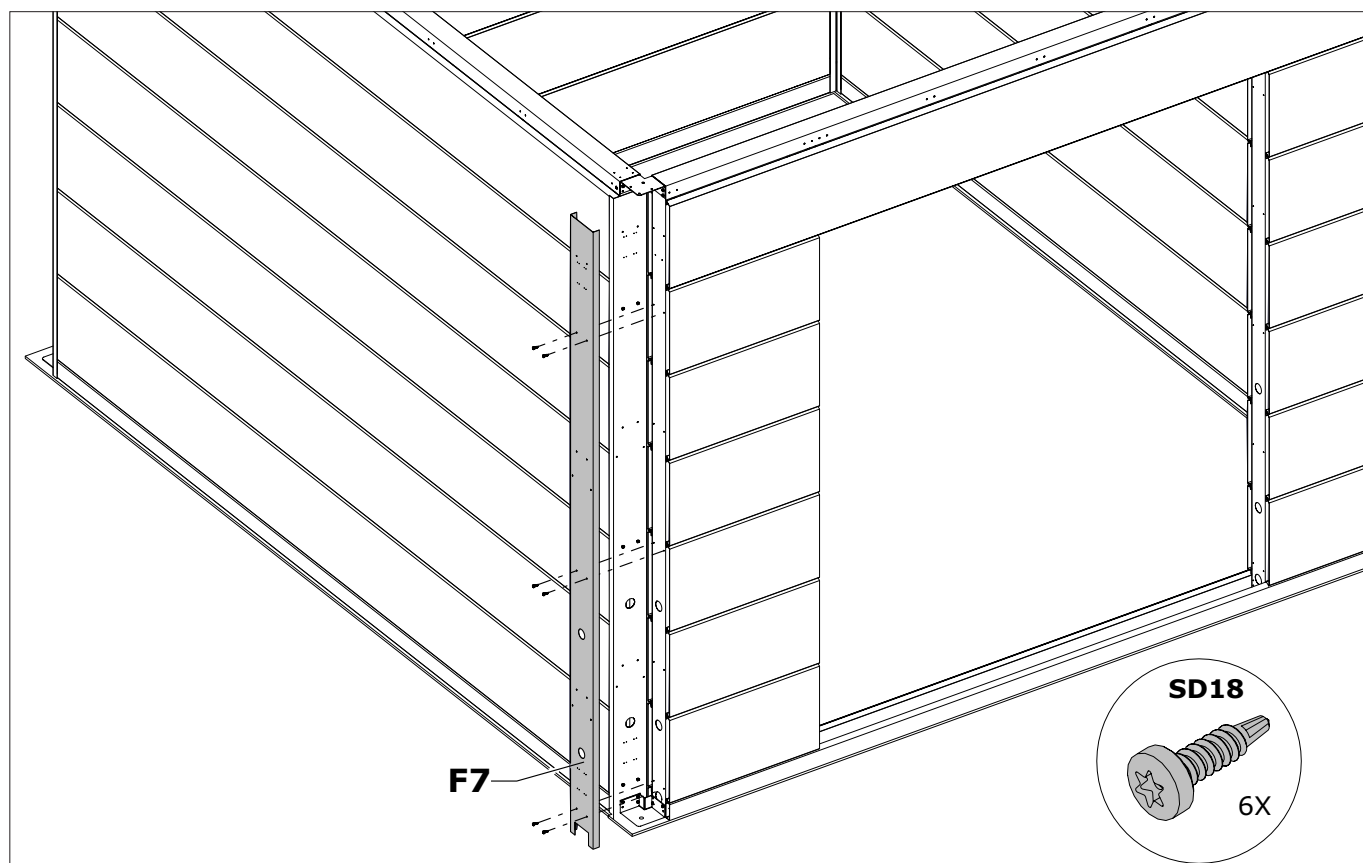

A Paroi / Wand / Wall / Wand

POW

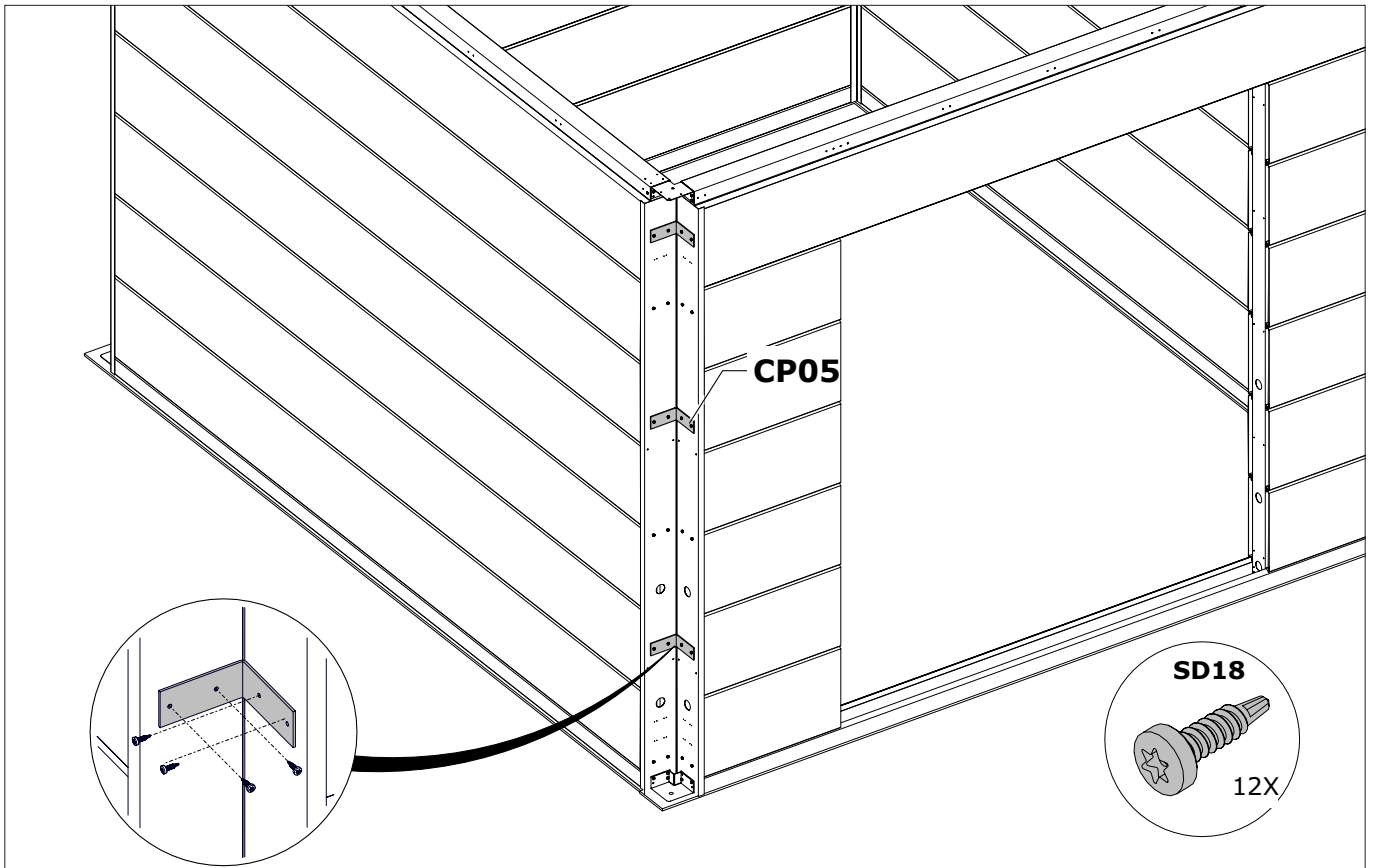

A Paroi / Wand / Wall / Wand

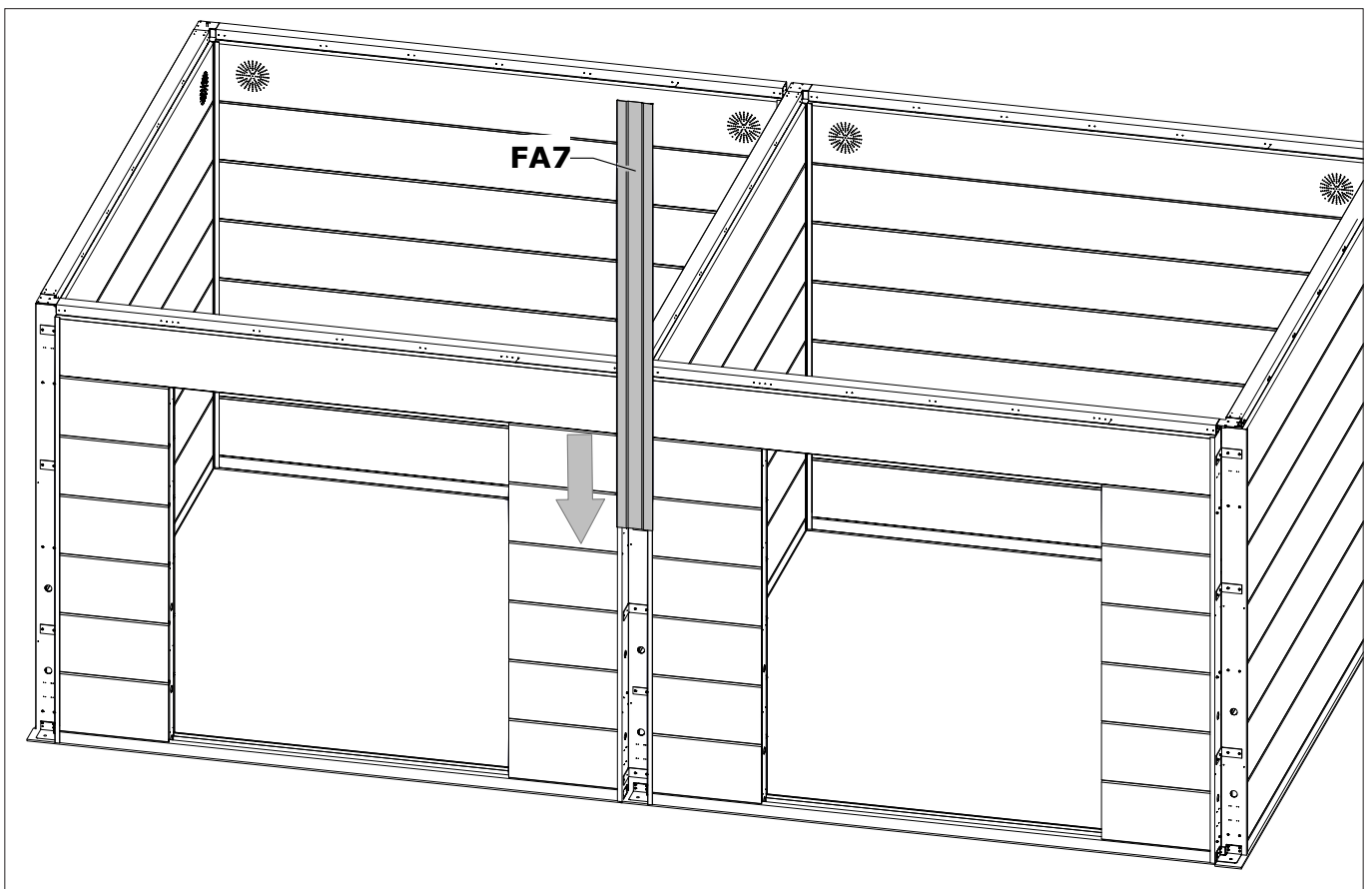

A Paroi / Wand / Wall / Wand

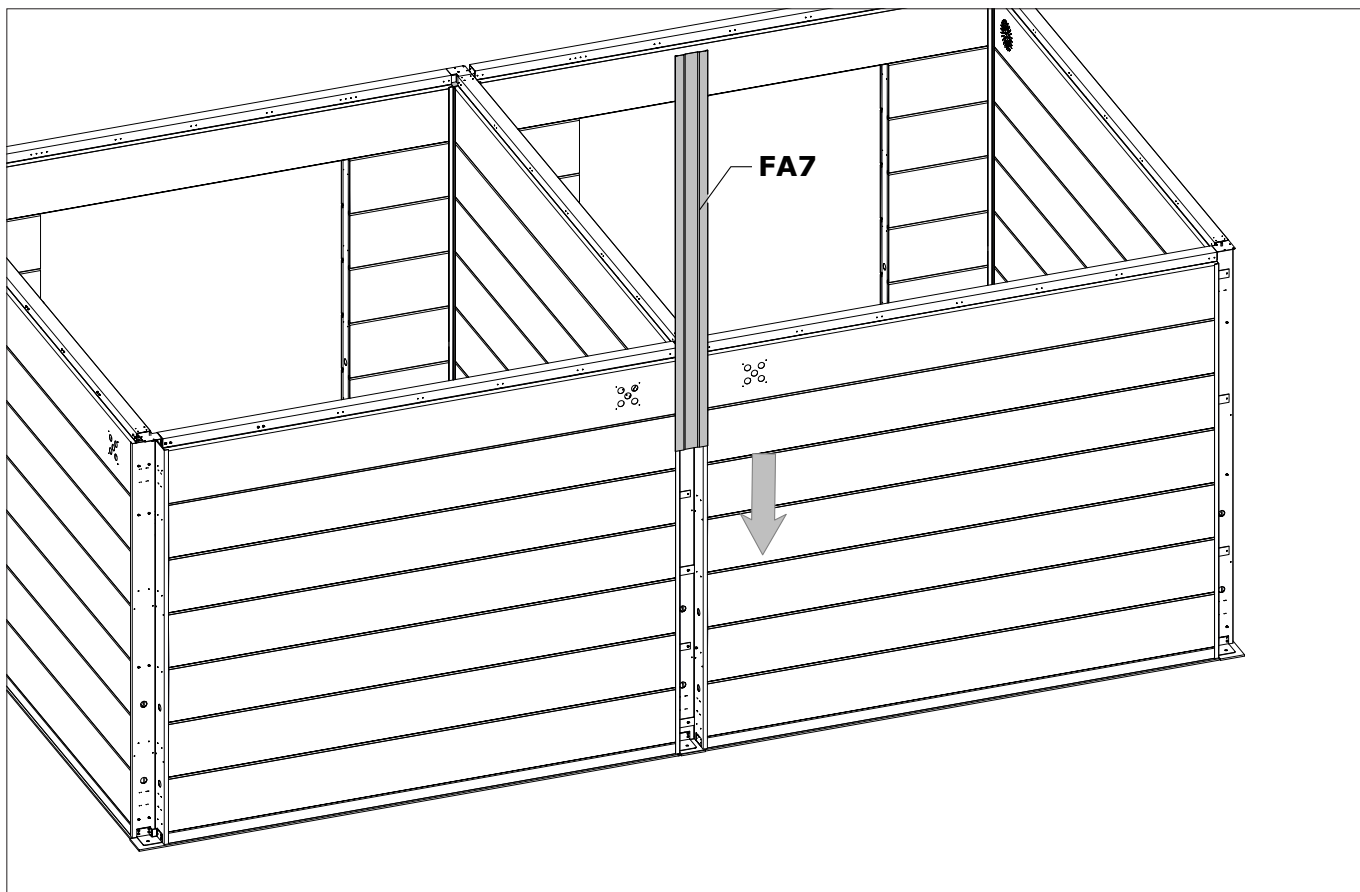

C Paroi / Wand / Wall / Wand

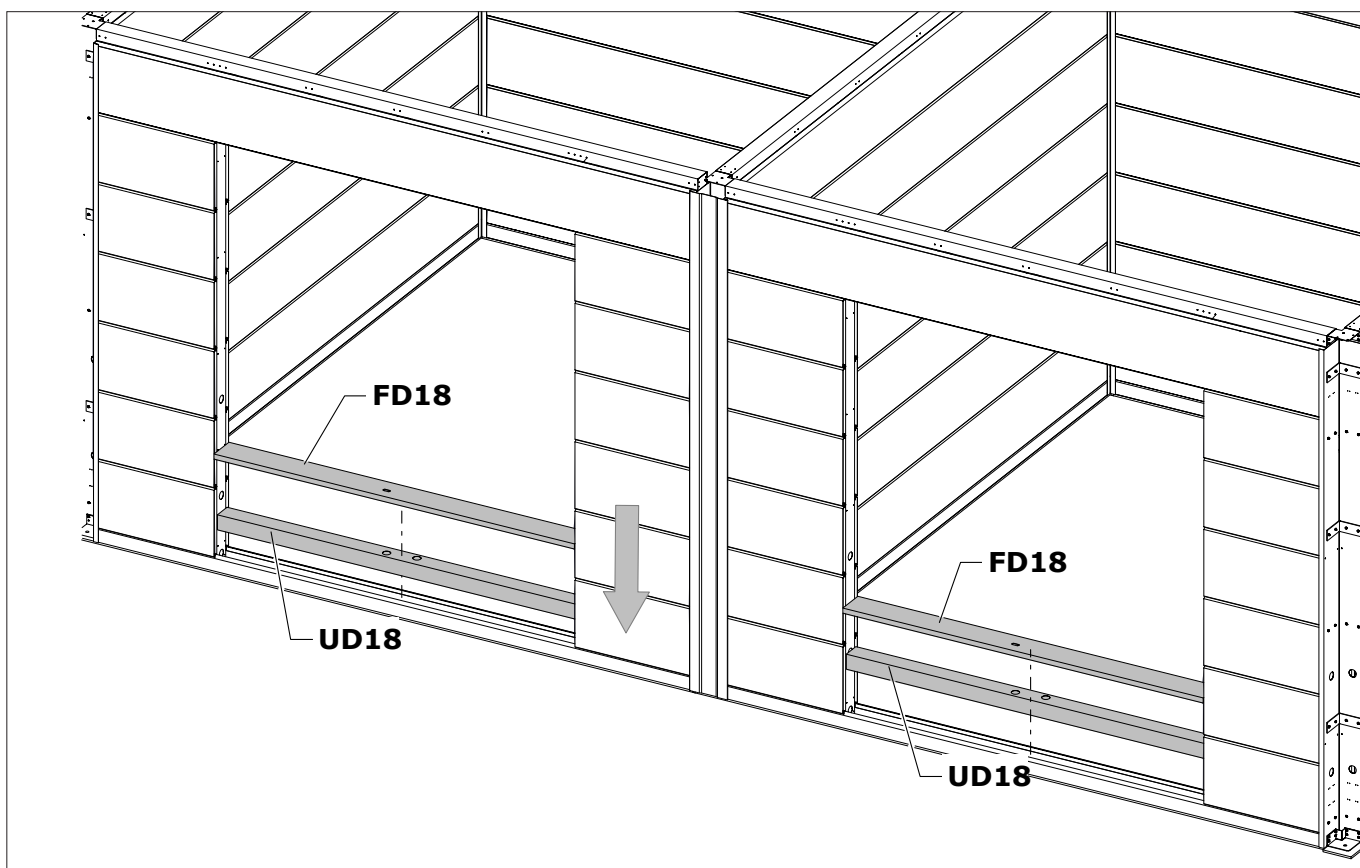

A Porte / Deur / Door / Tür

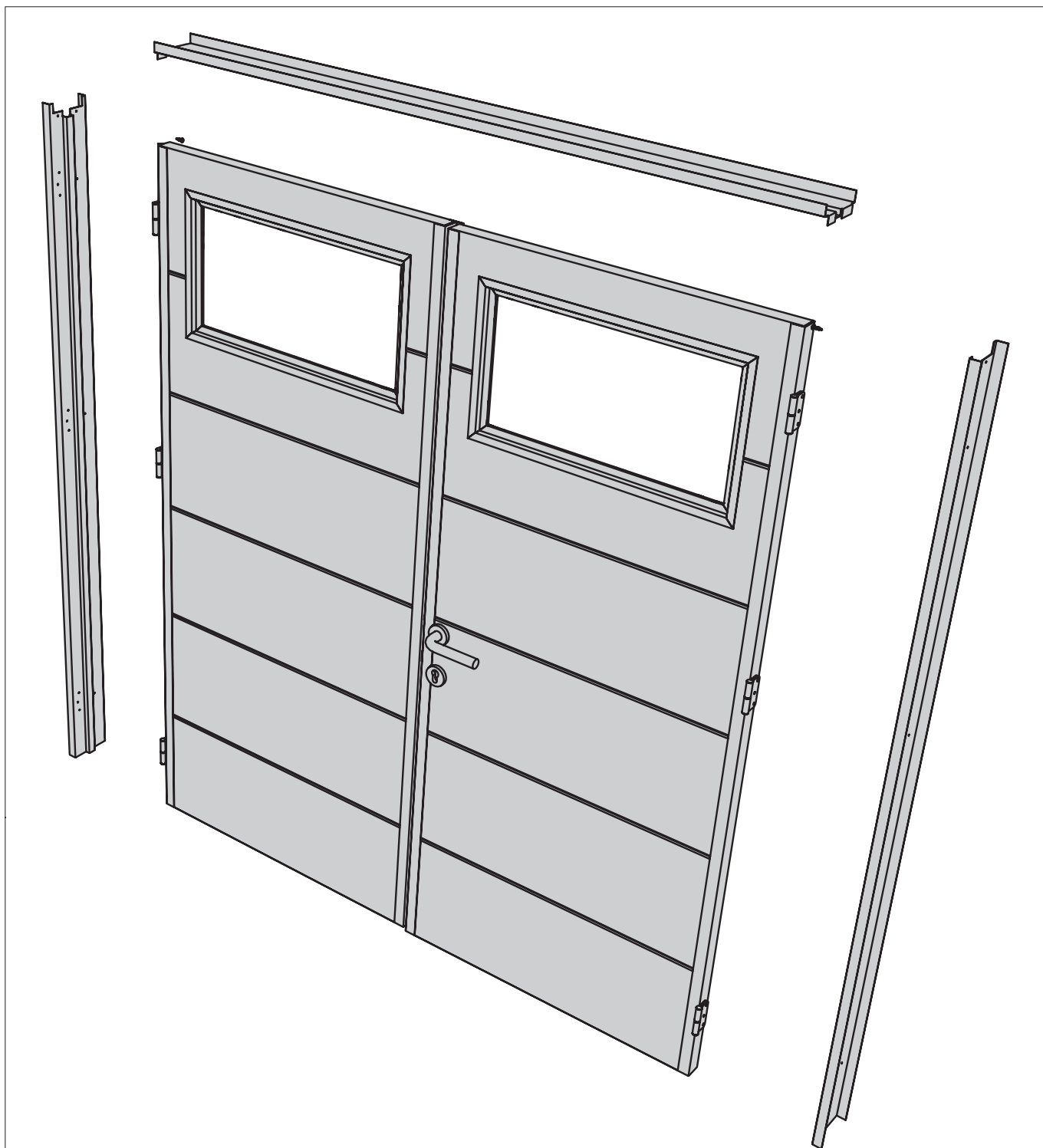

**Installez la porte maintenant, voir la pièce jointe.
Installeer de deur nu, zie bijlage.
Install the door now, see attachment.
Bauen Sie jetzt die Tür ein, siehe Anhang.**

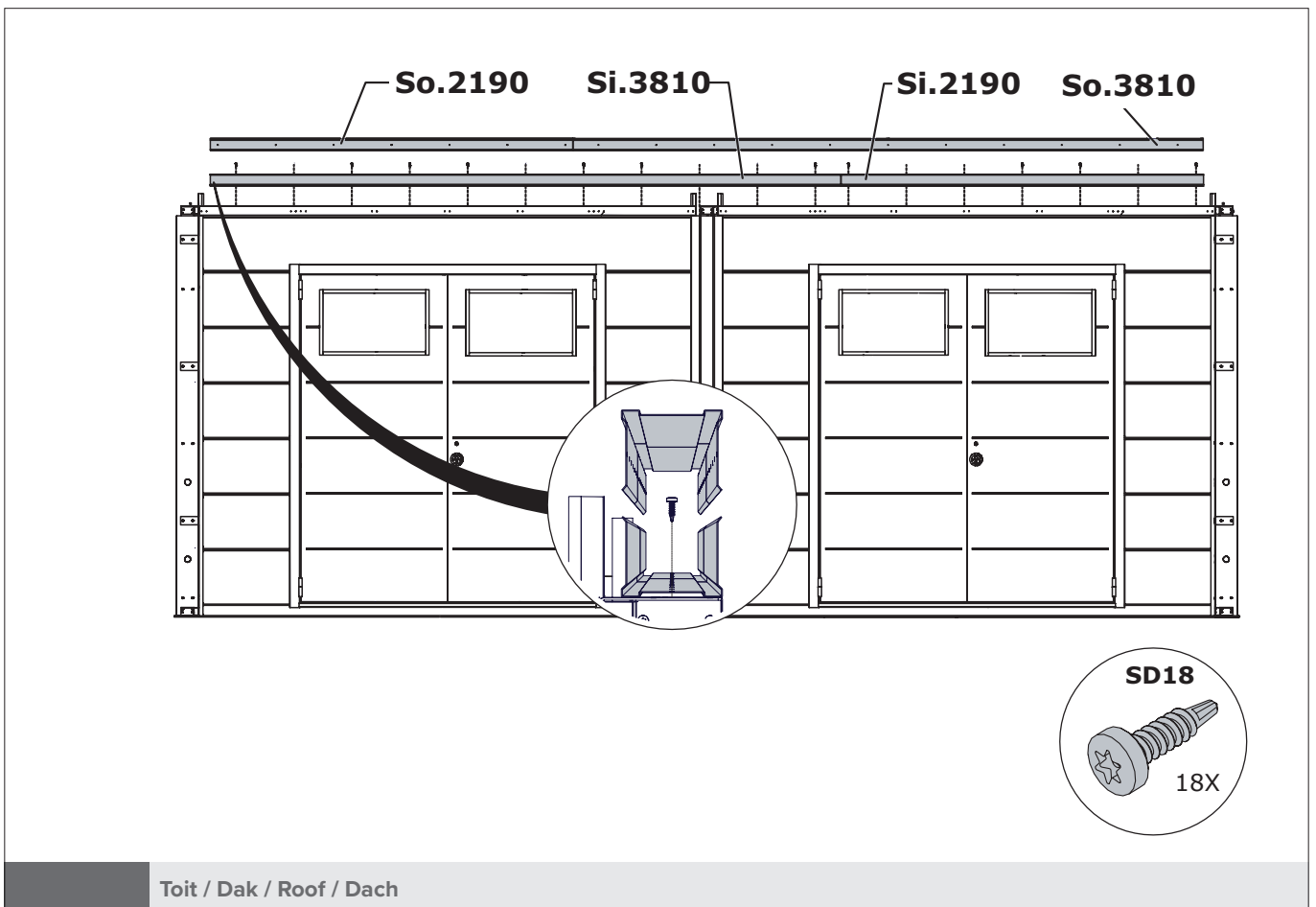
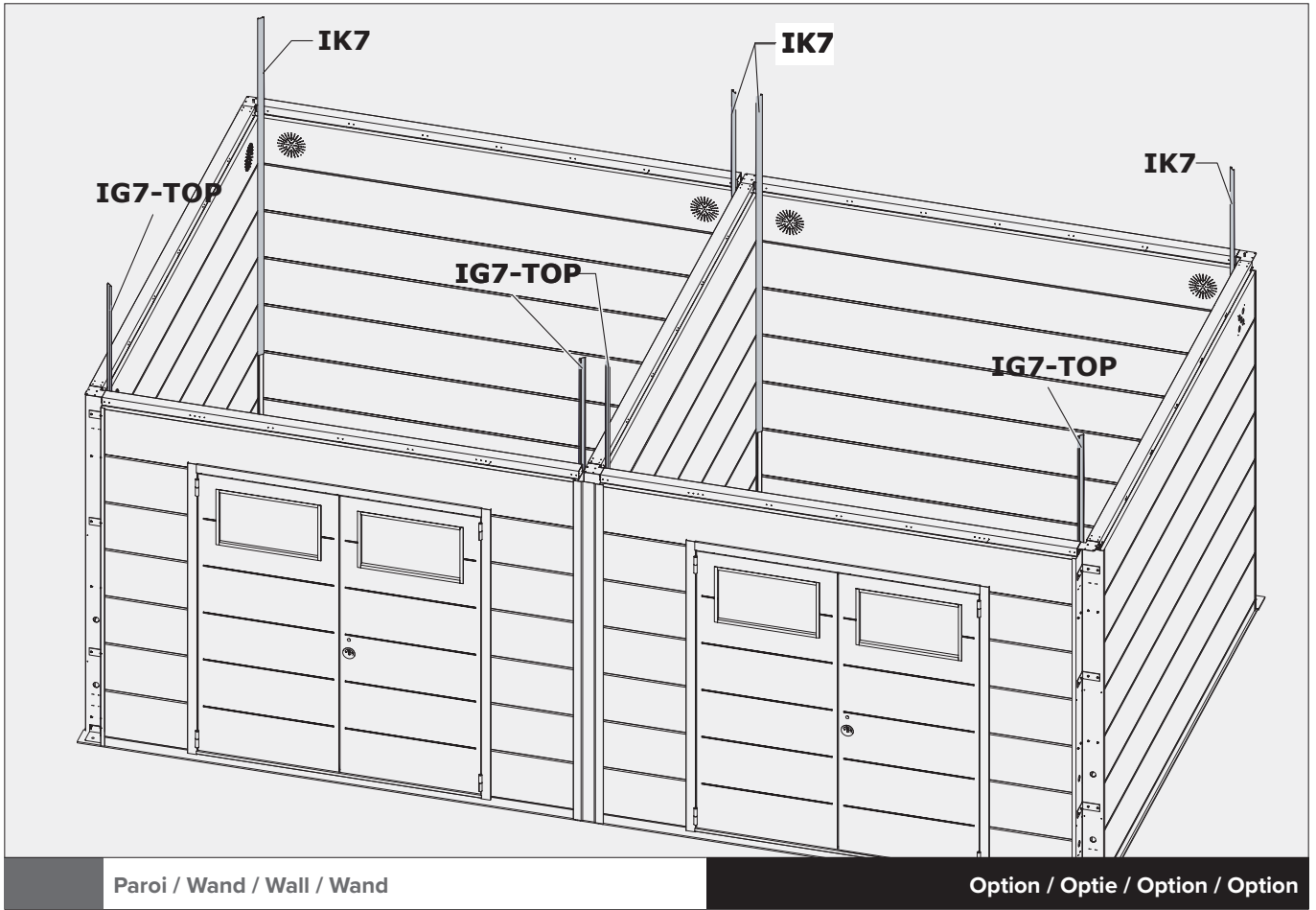

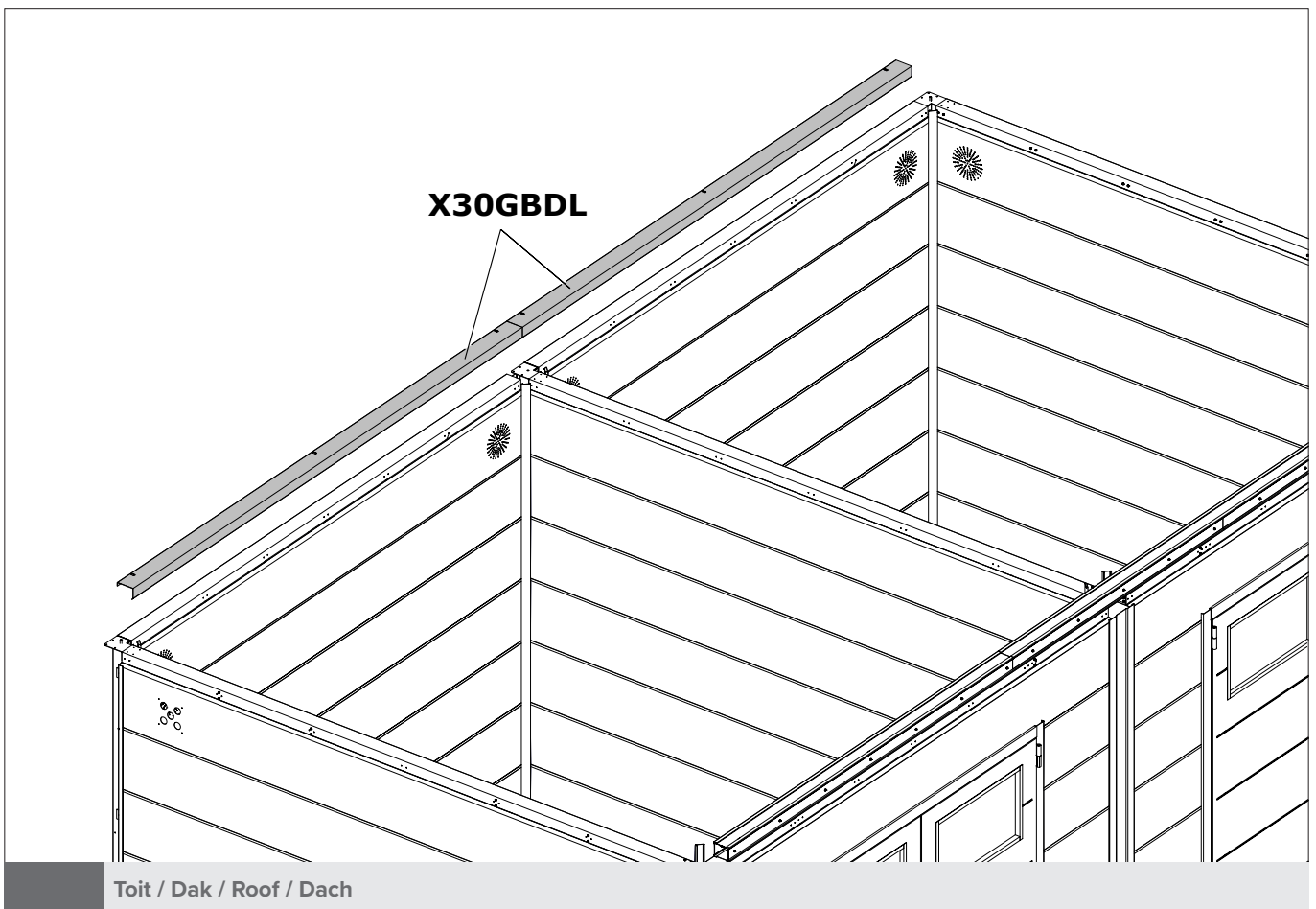
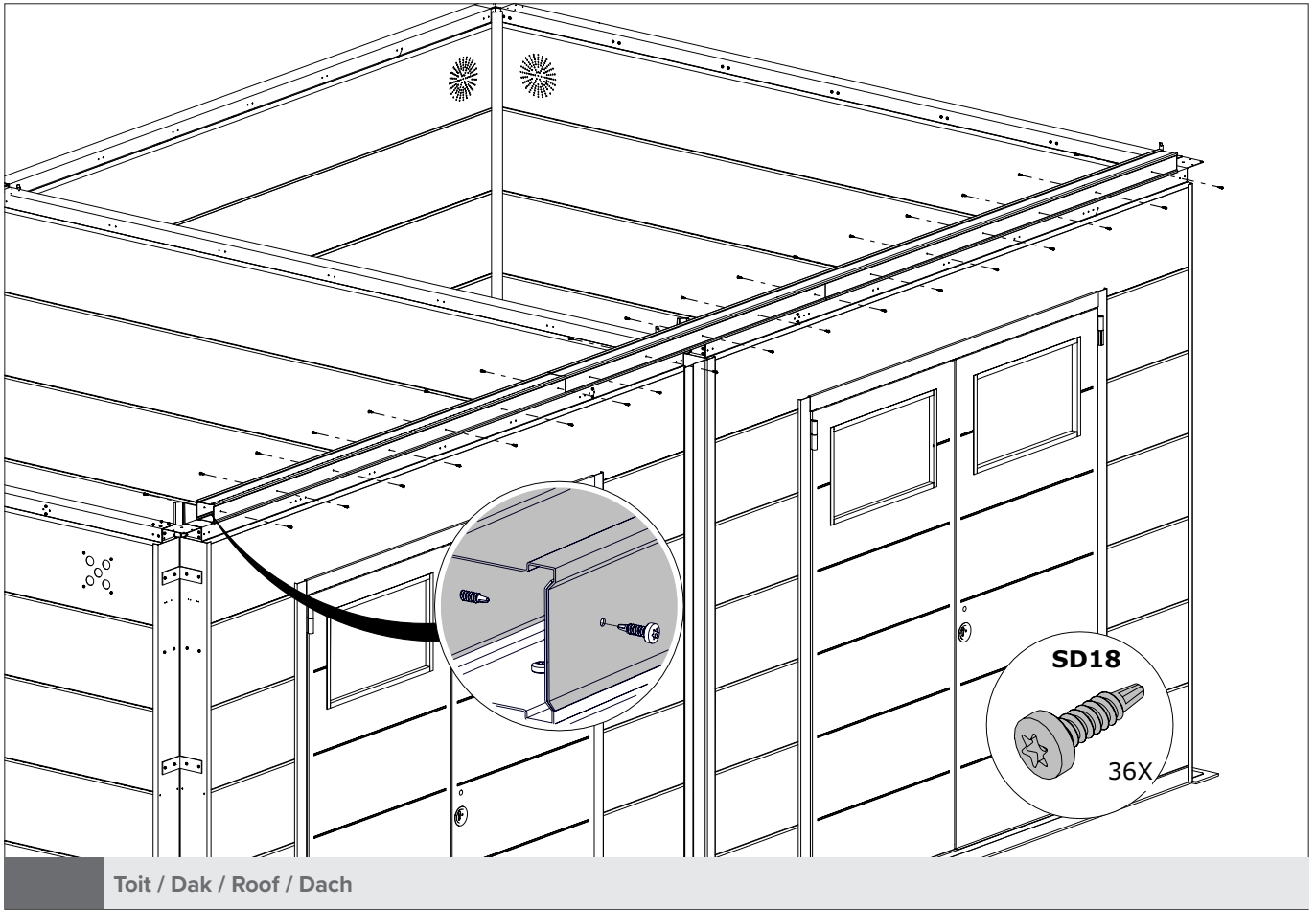

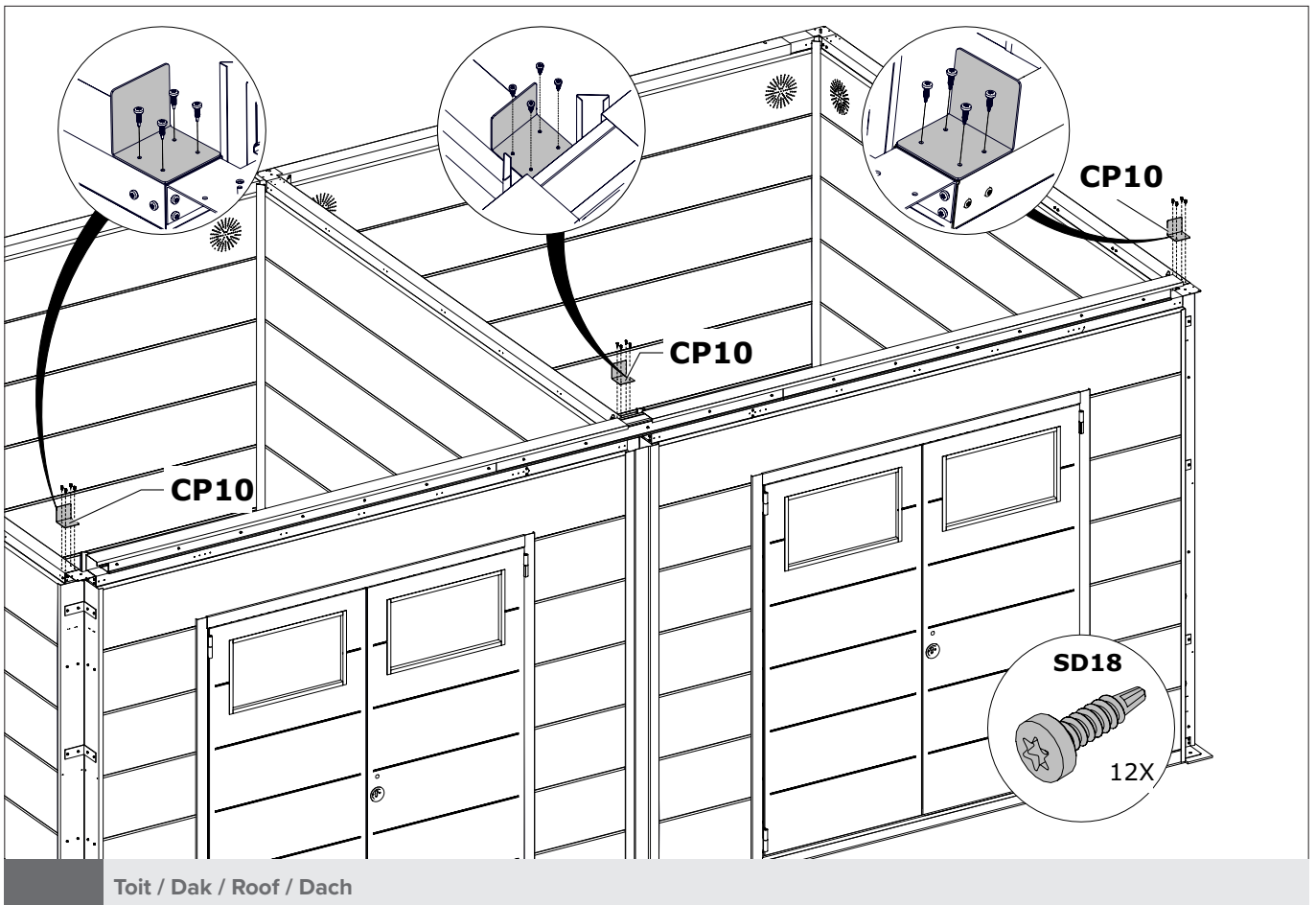
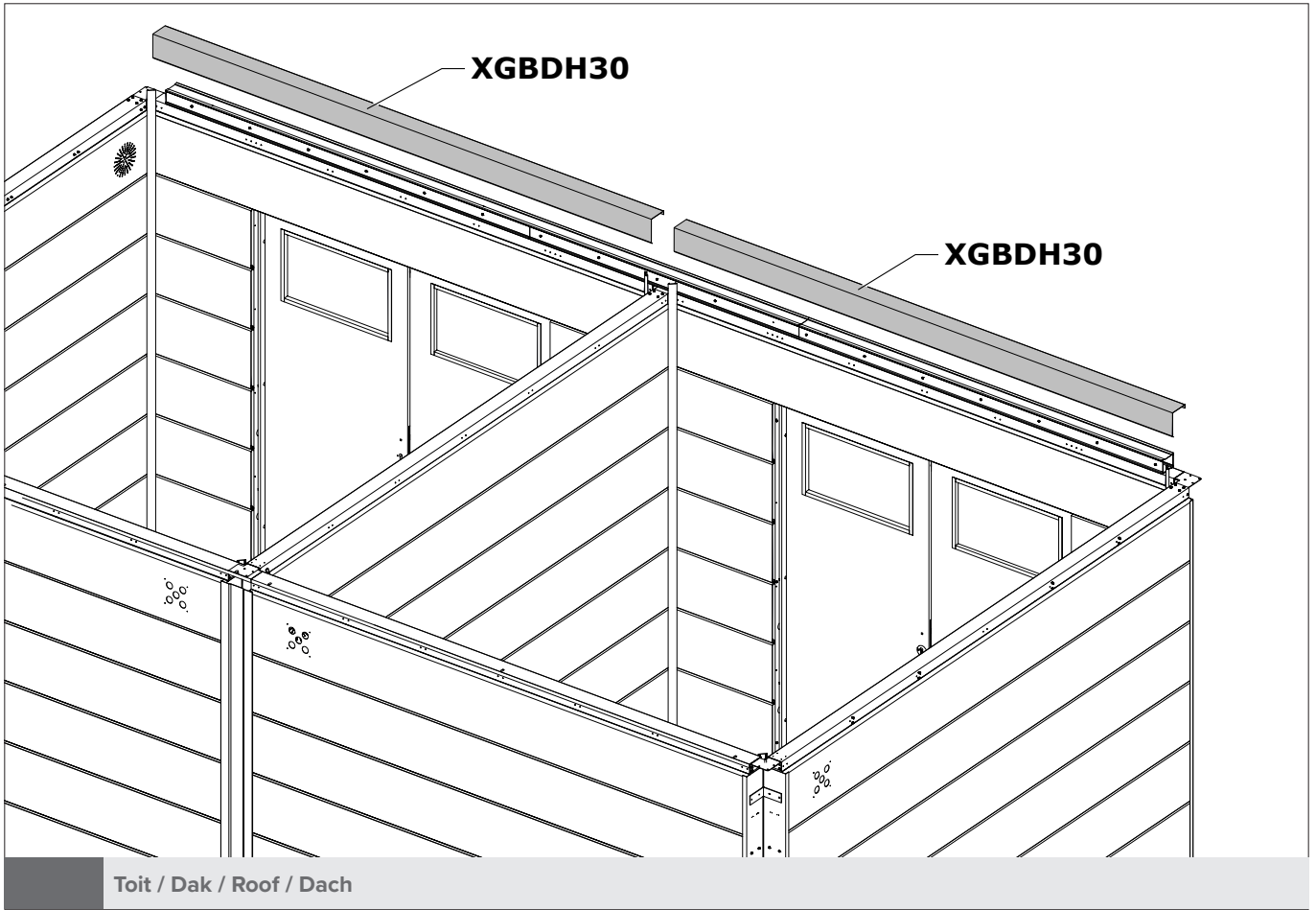

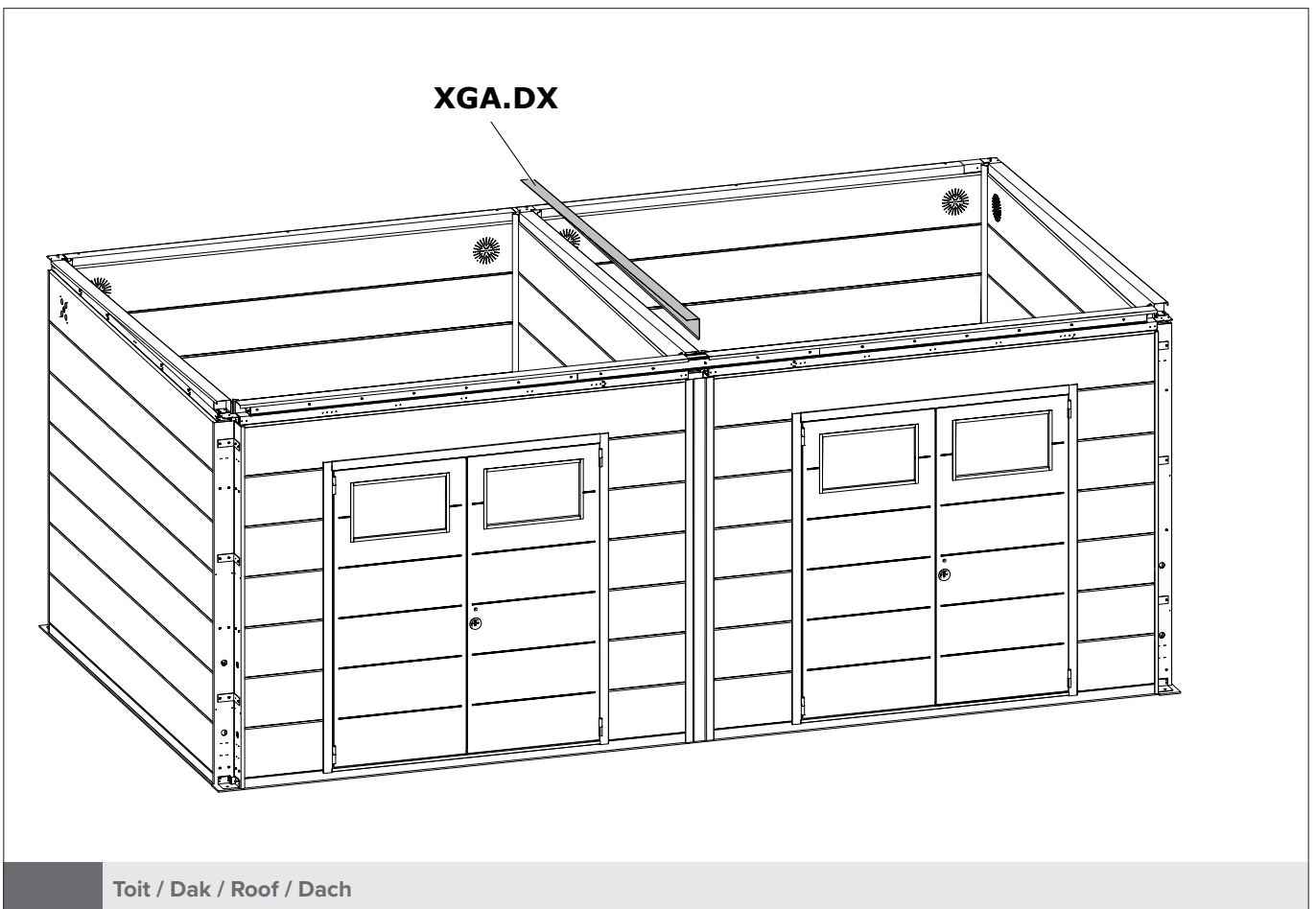
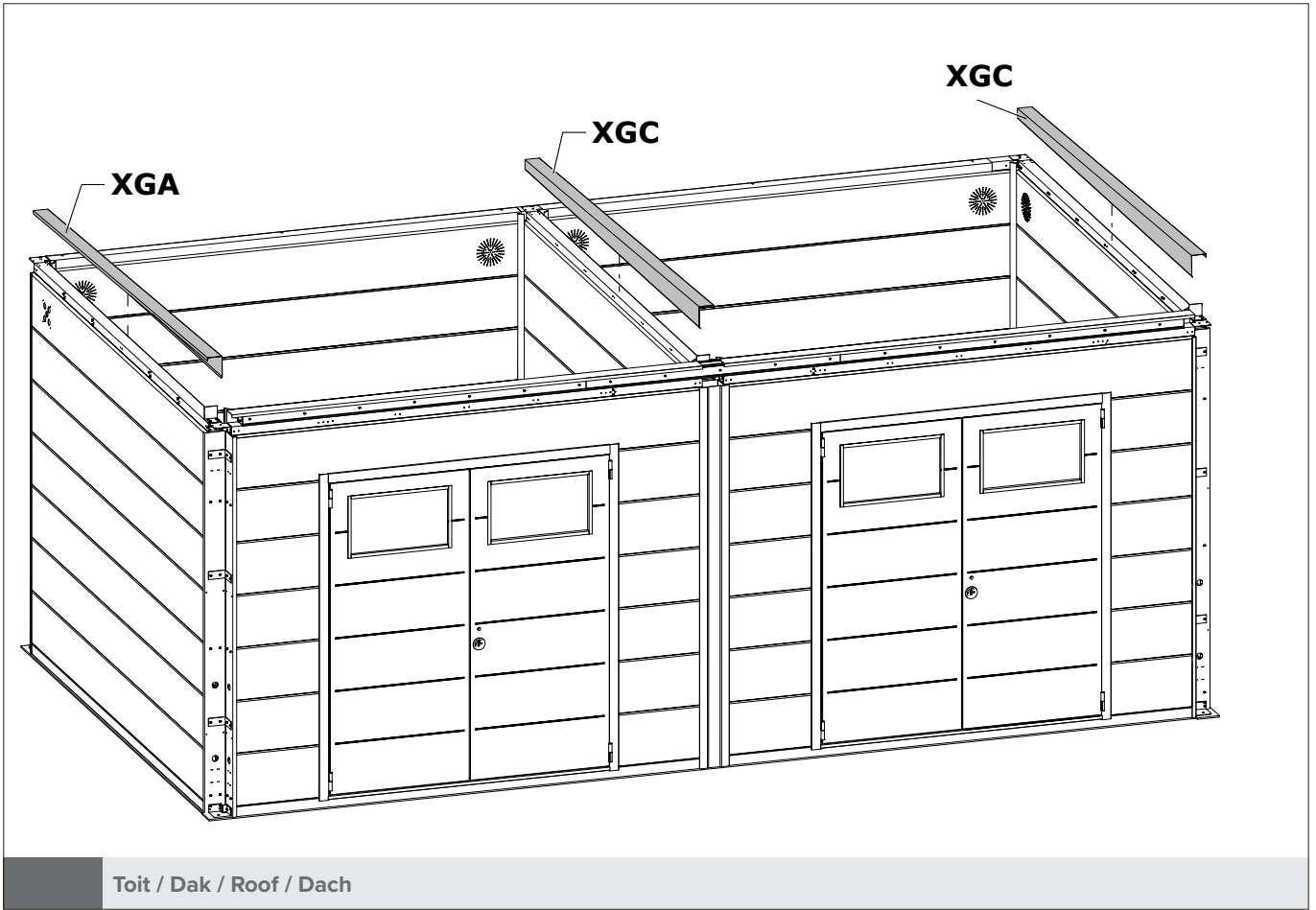

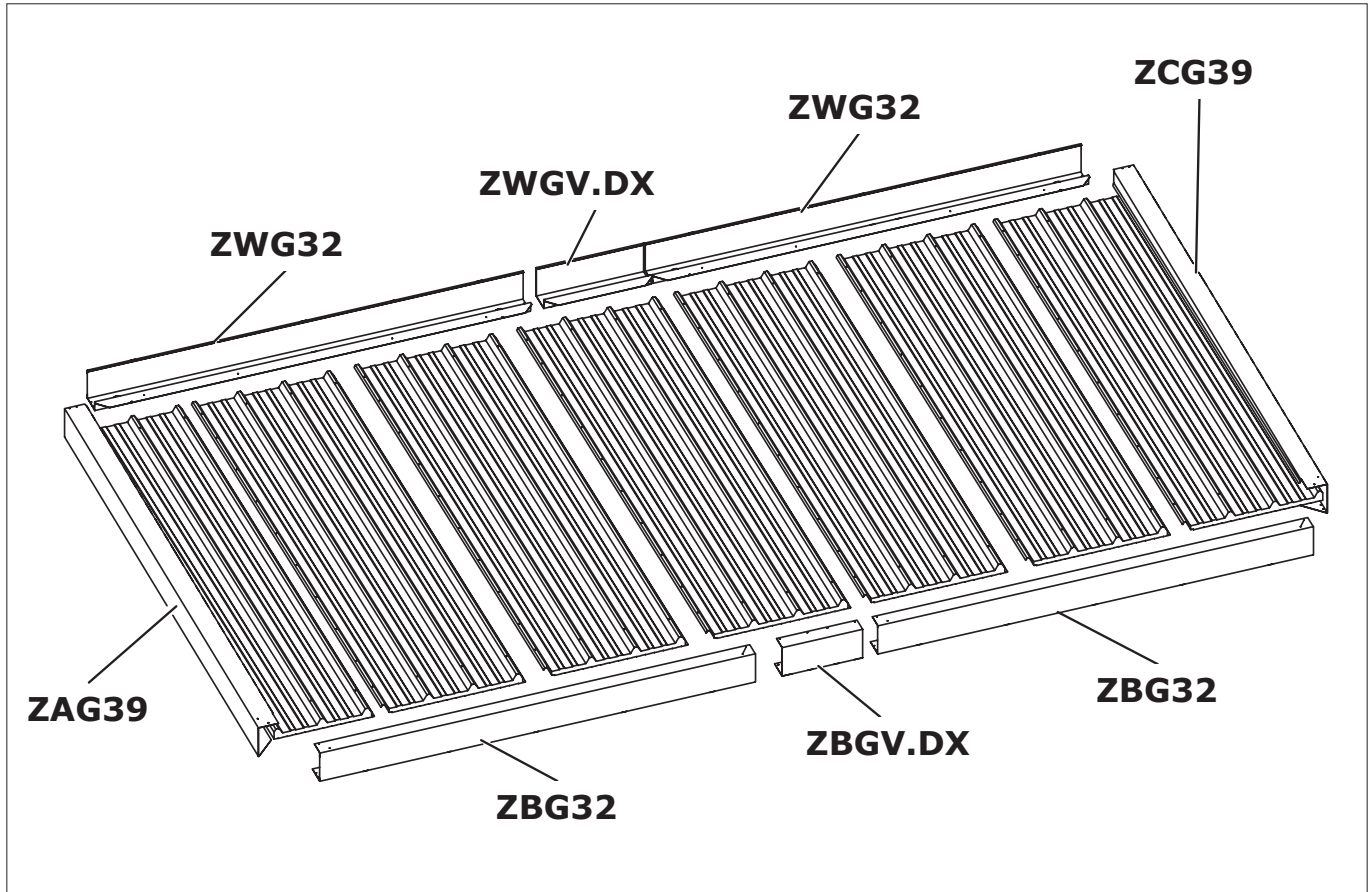

Toit / Dak / Roof / Dach

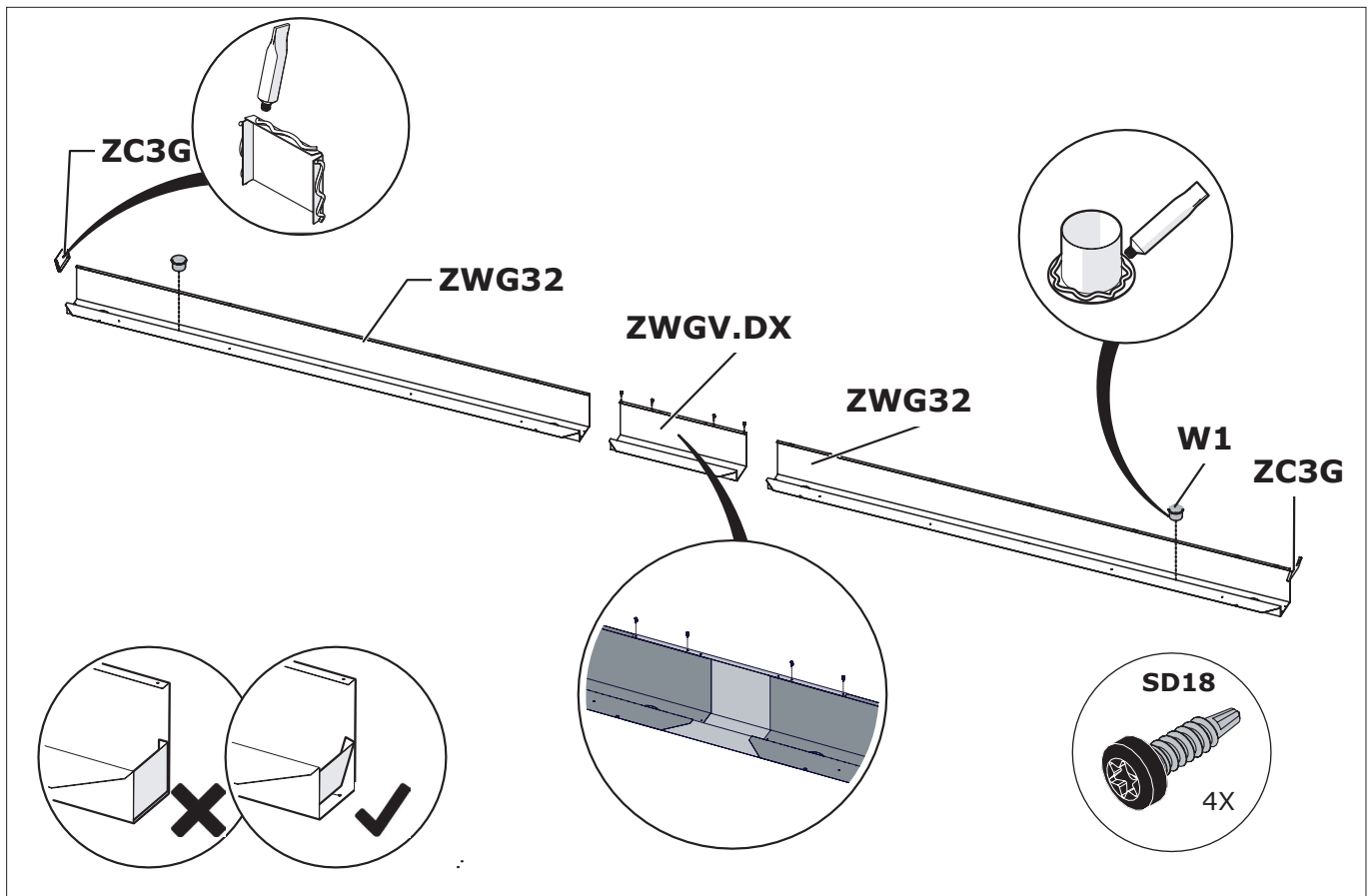

Toit / Dak / Roof / Dach

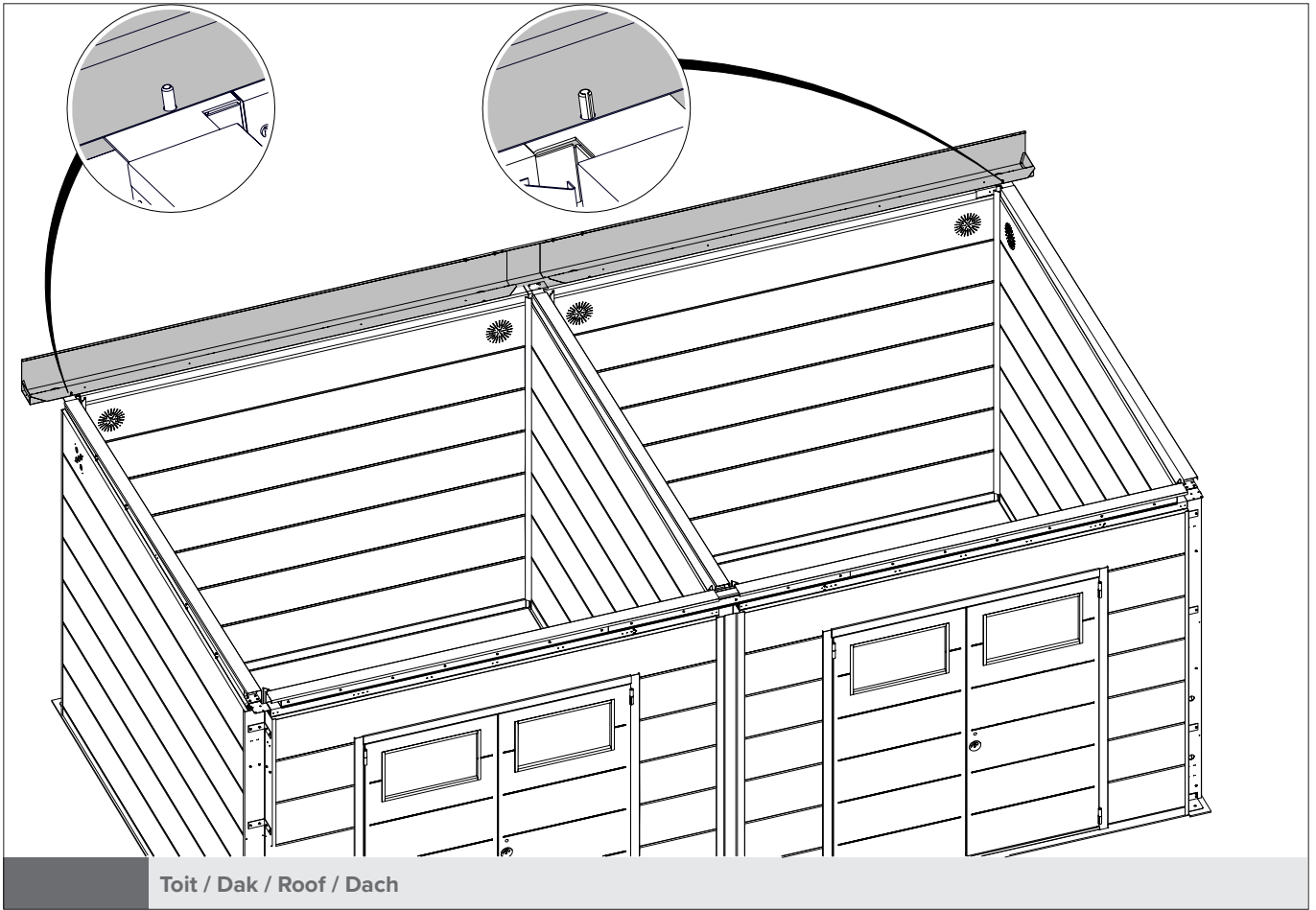

Toit / Dak / Roof / Dach

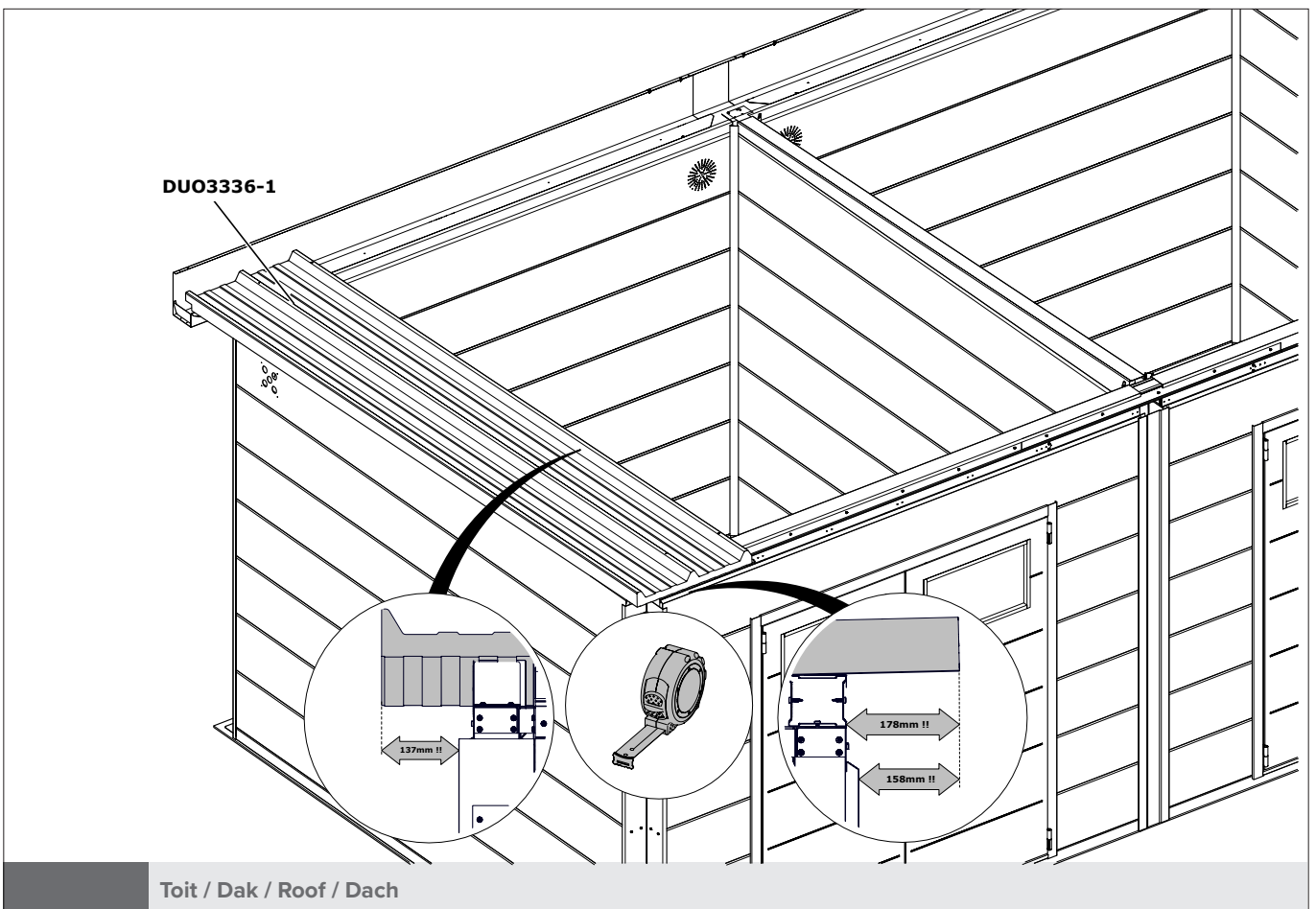

Toit / Dak / Roof / Dach

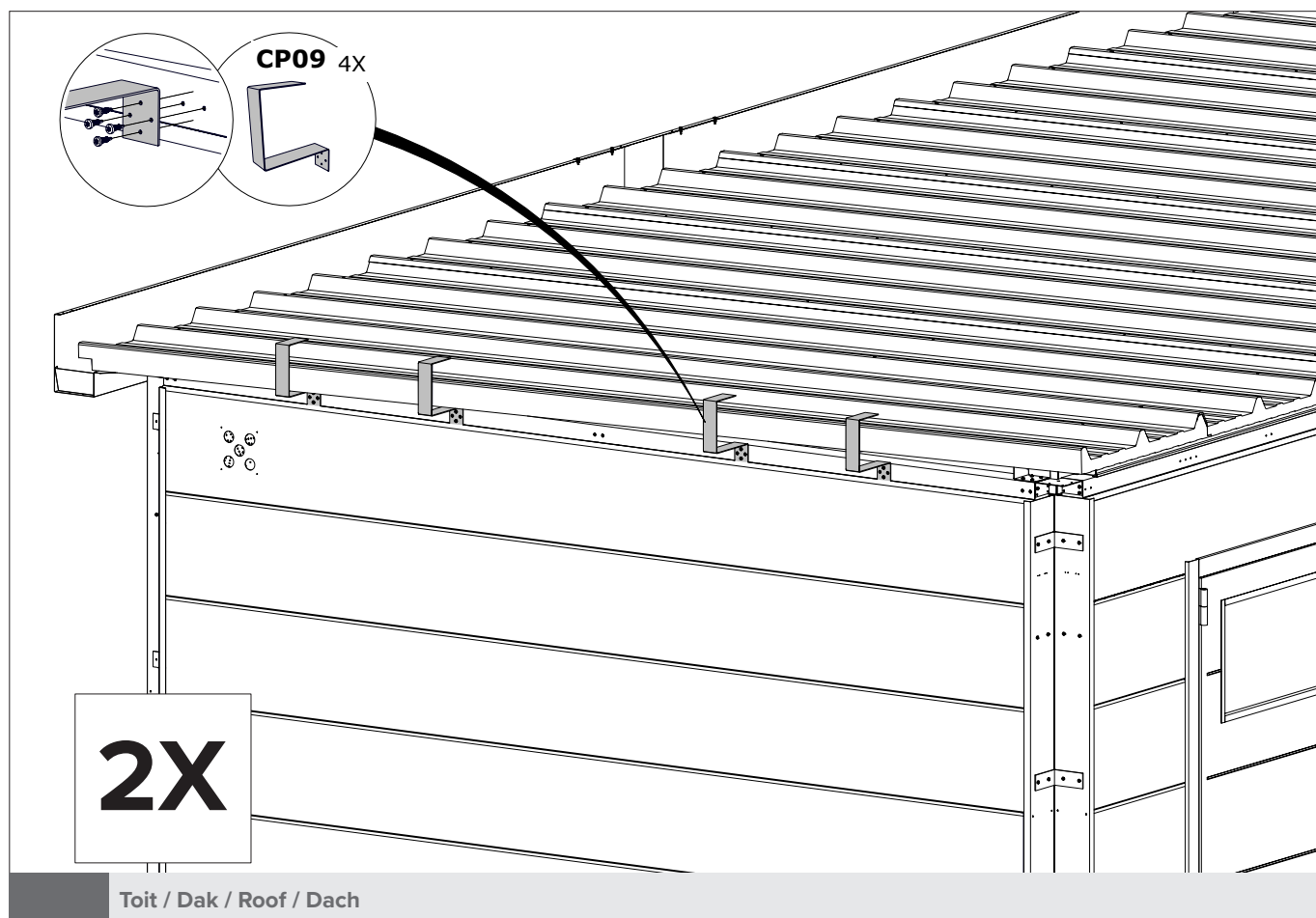
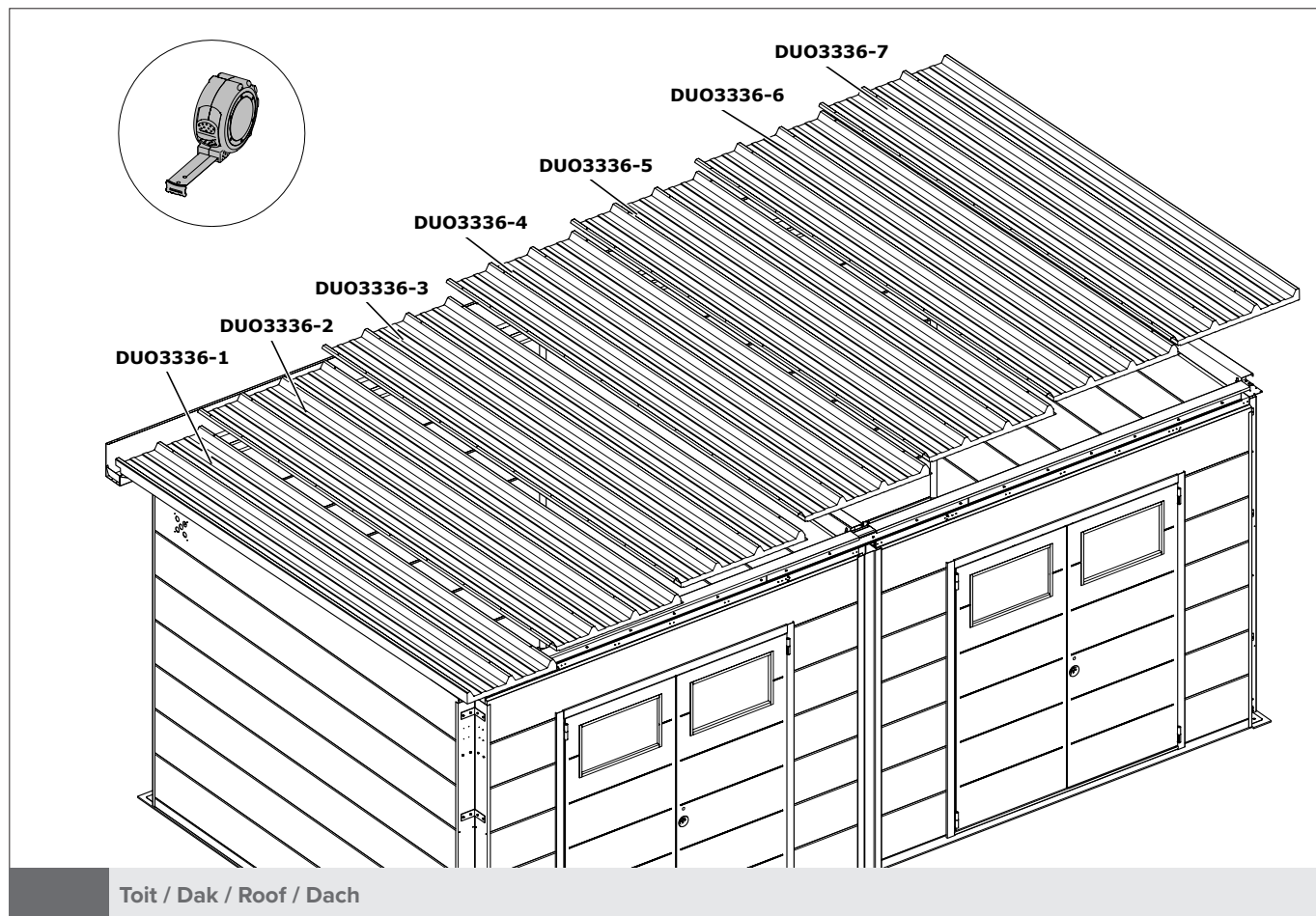

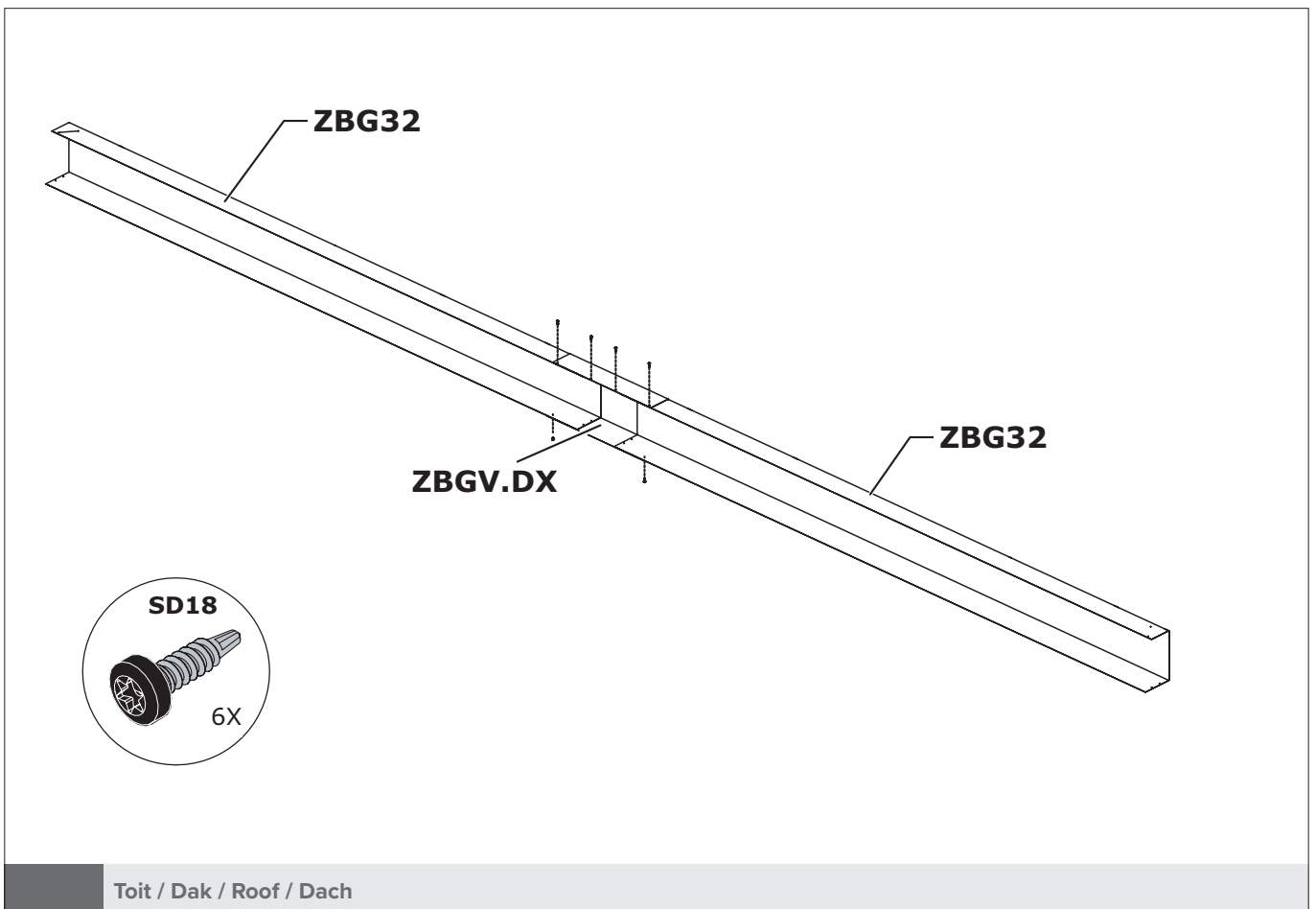
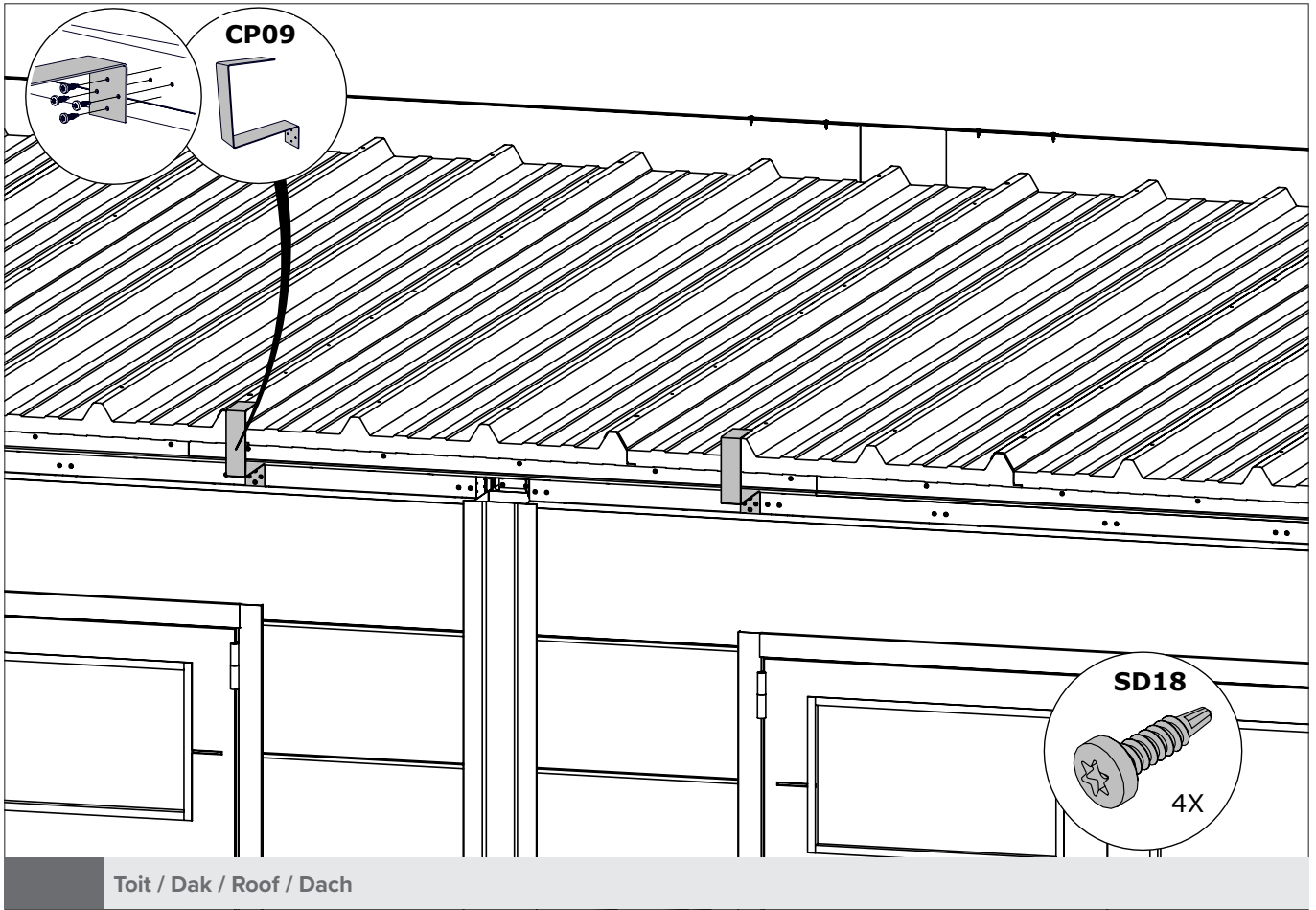

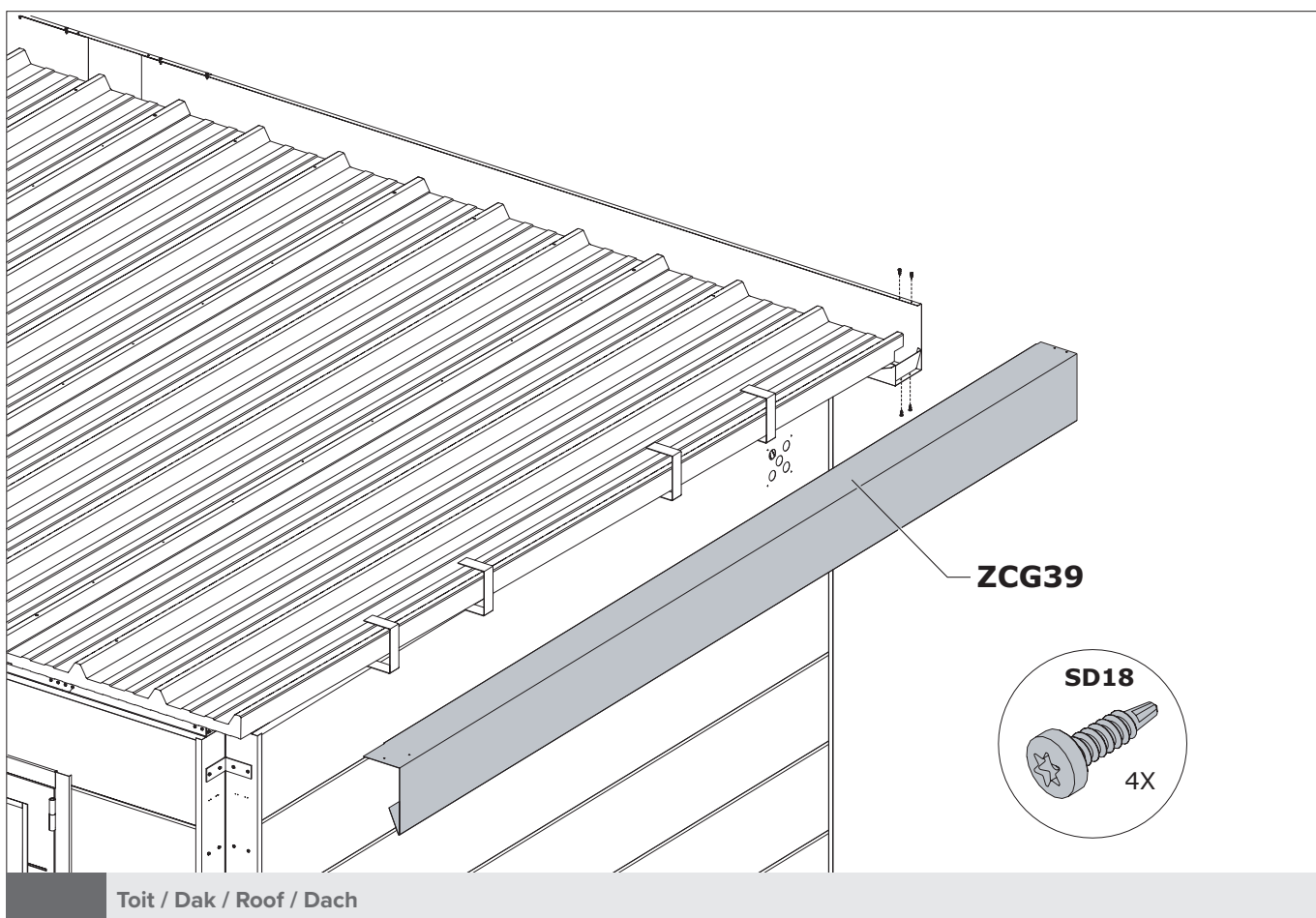
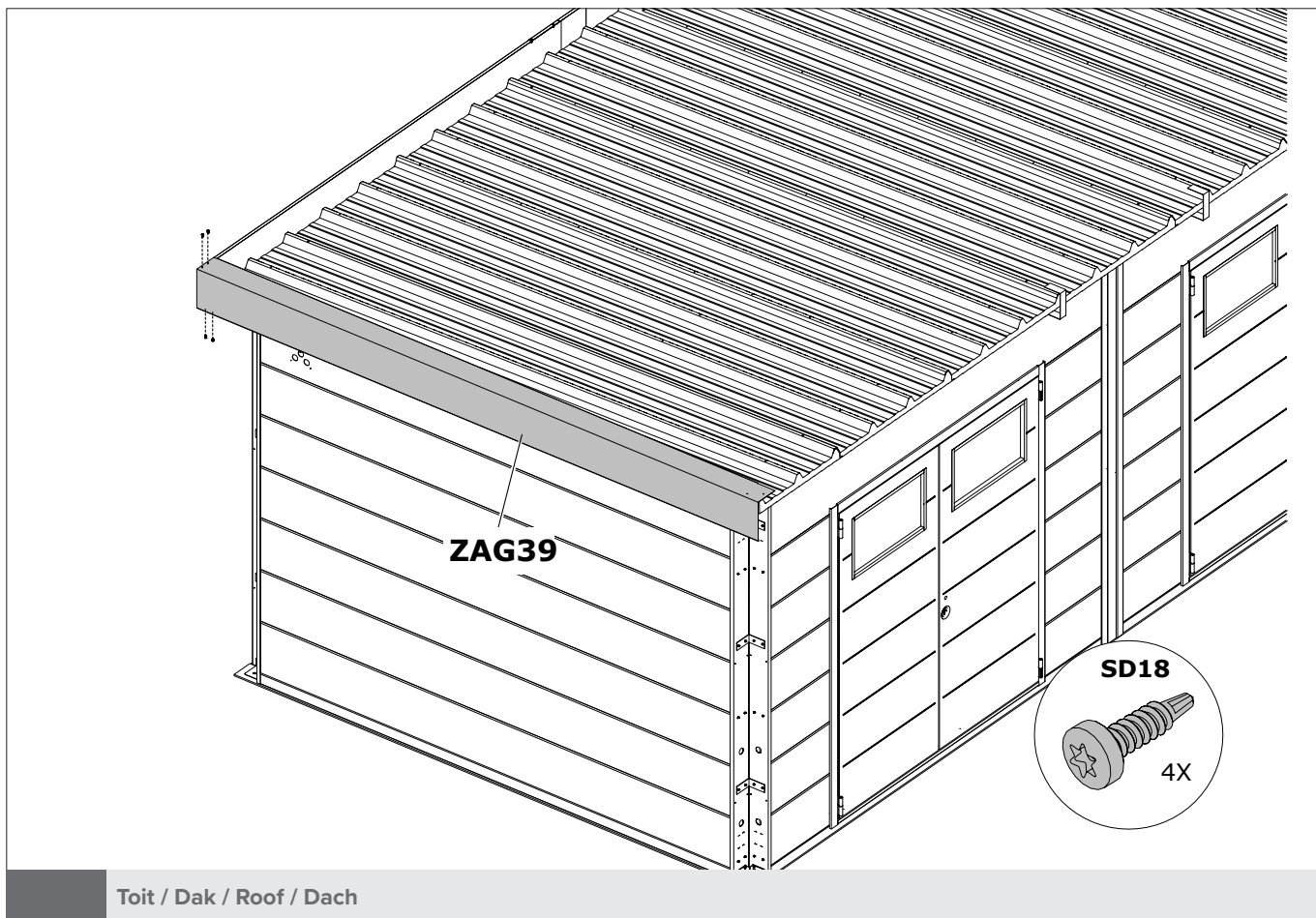

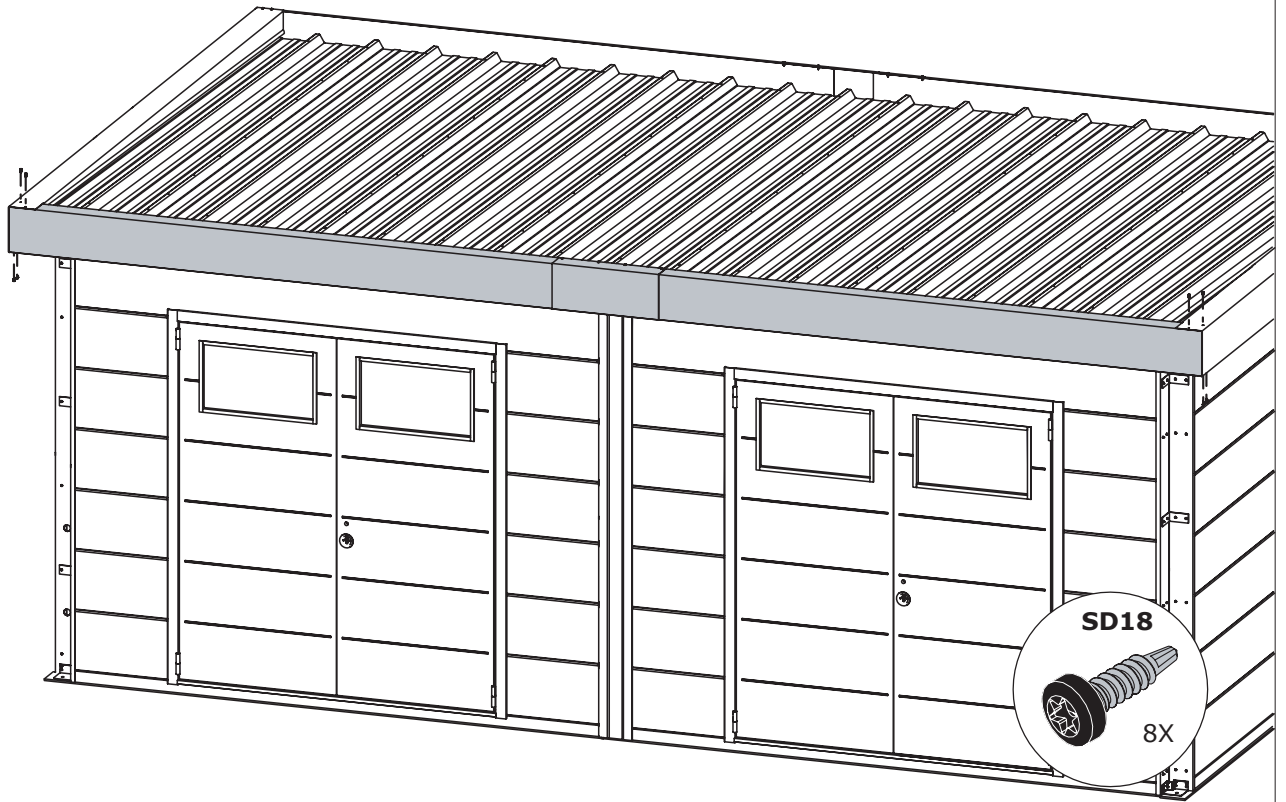

Toit / Dak / Roof / Dach

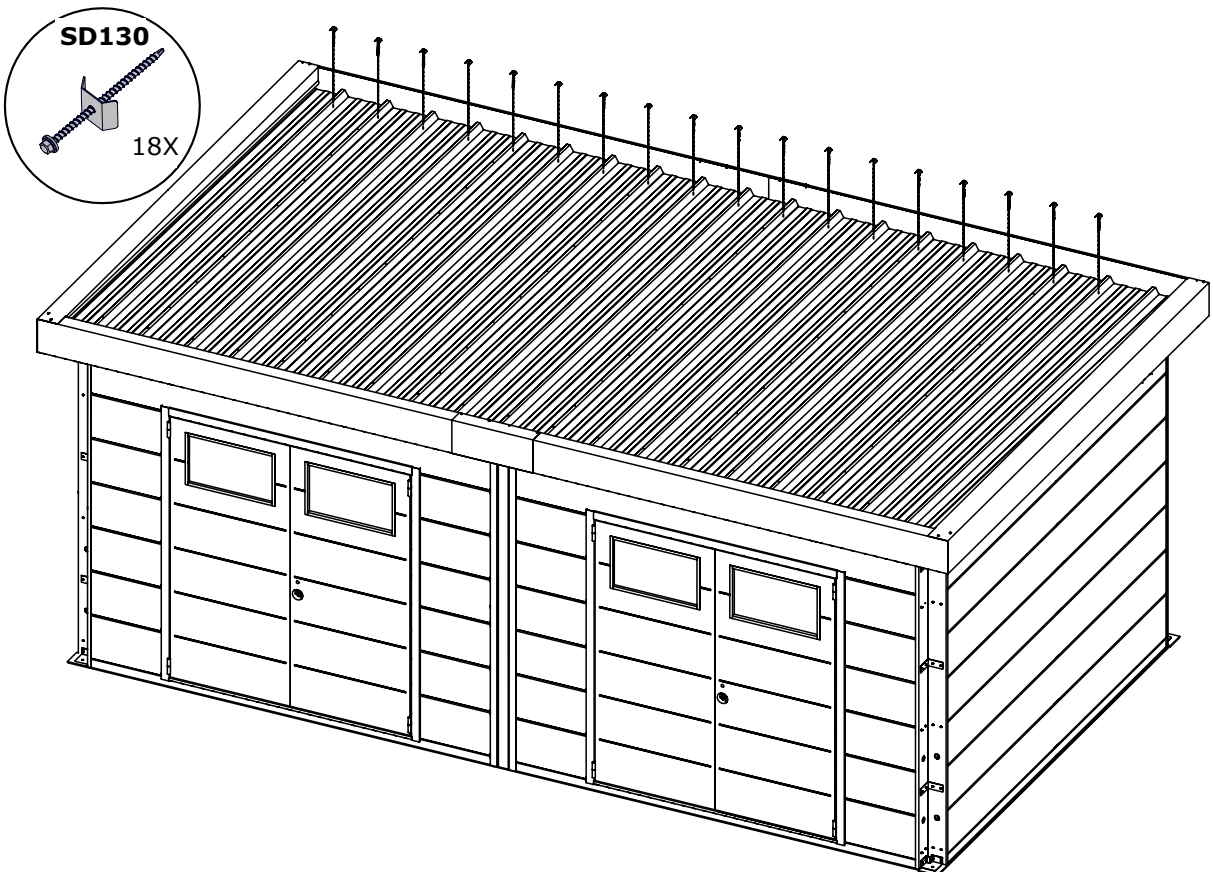

Toit / Dak / Roof / Dach

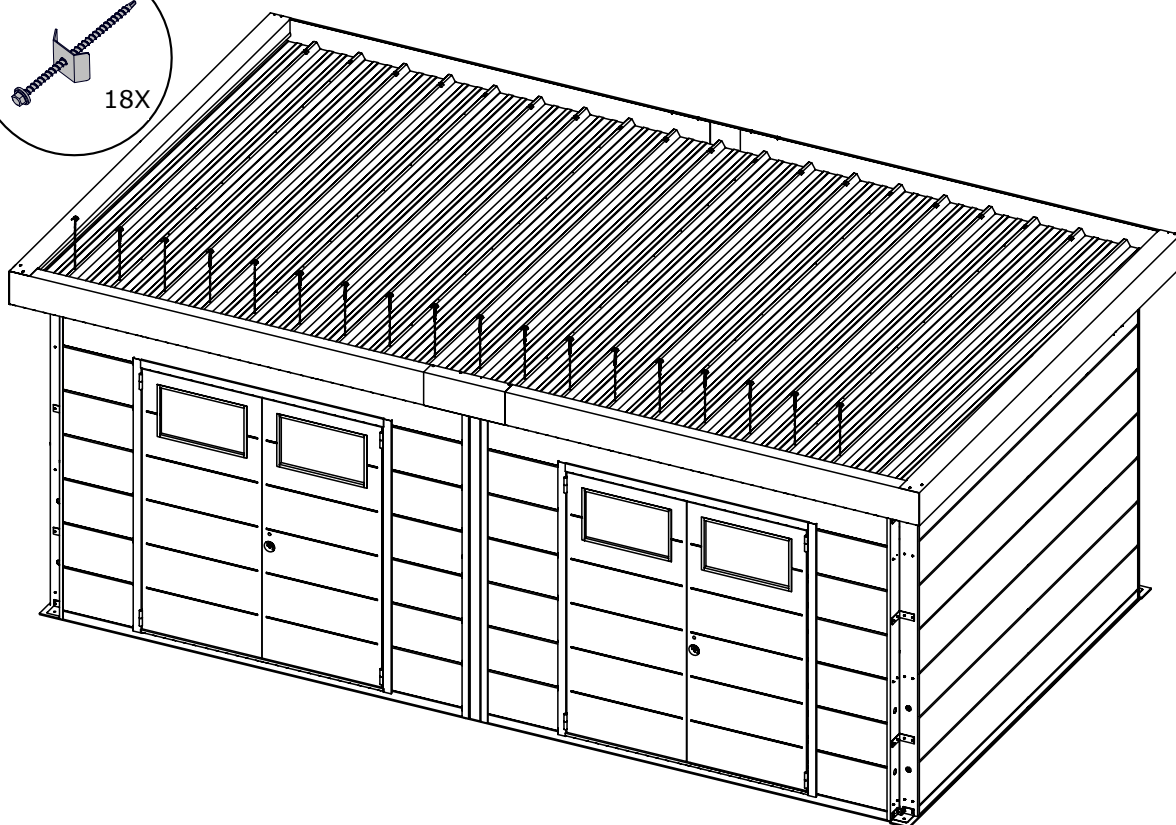
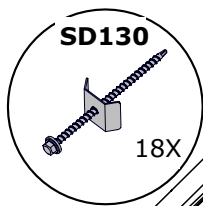

Toit / Dak / Roof / Dach

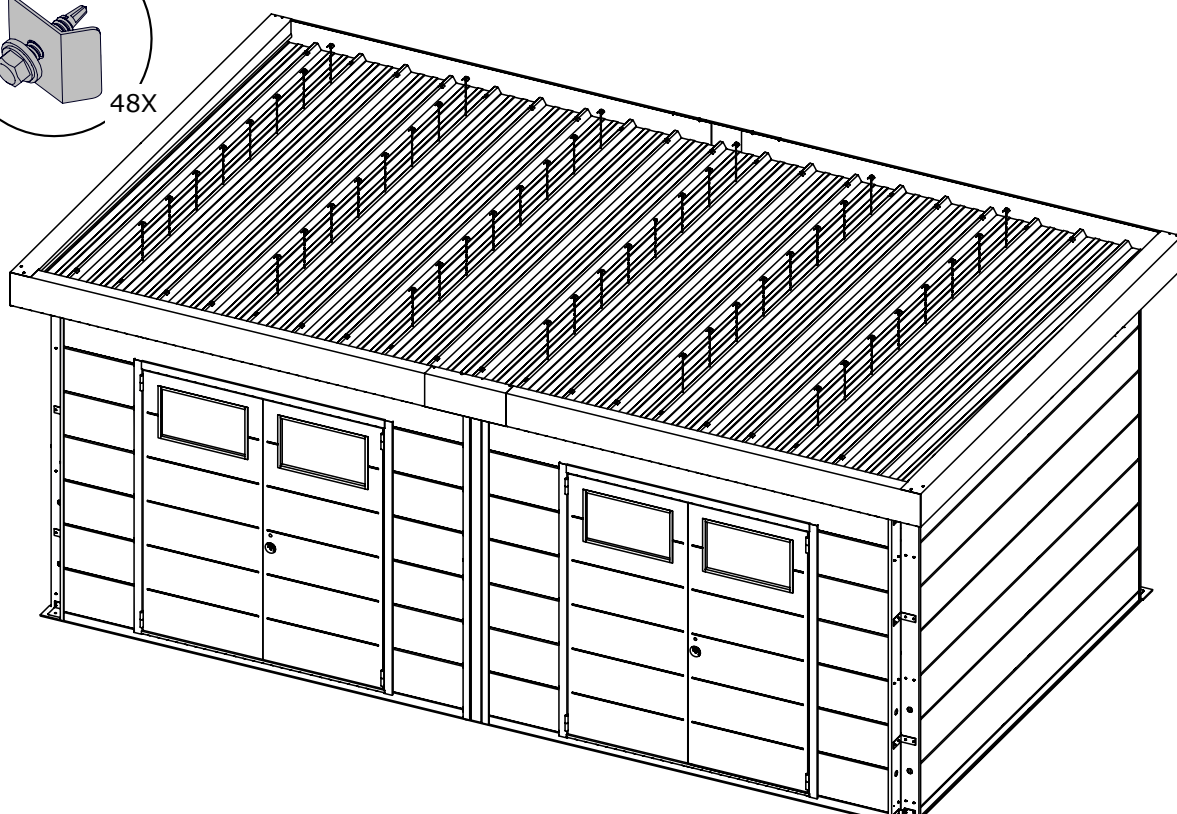
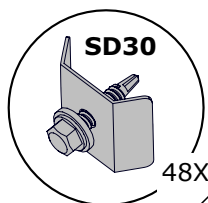

Toit / Dak / Roof / Dach

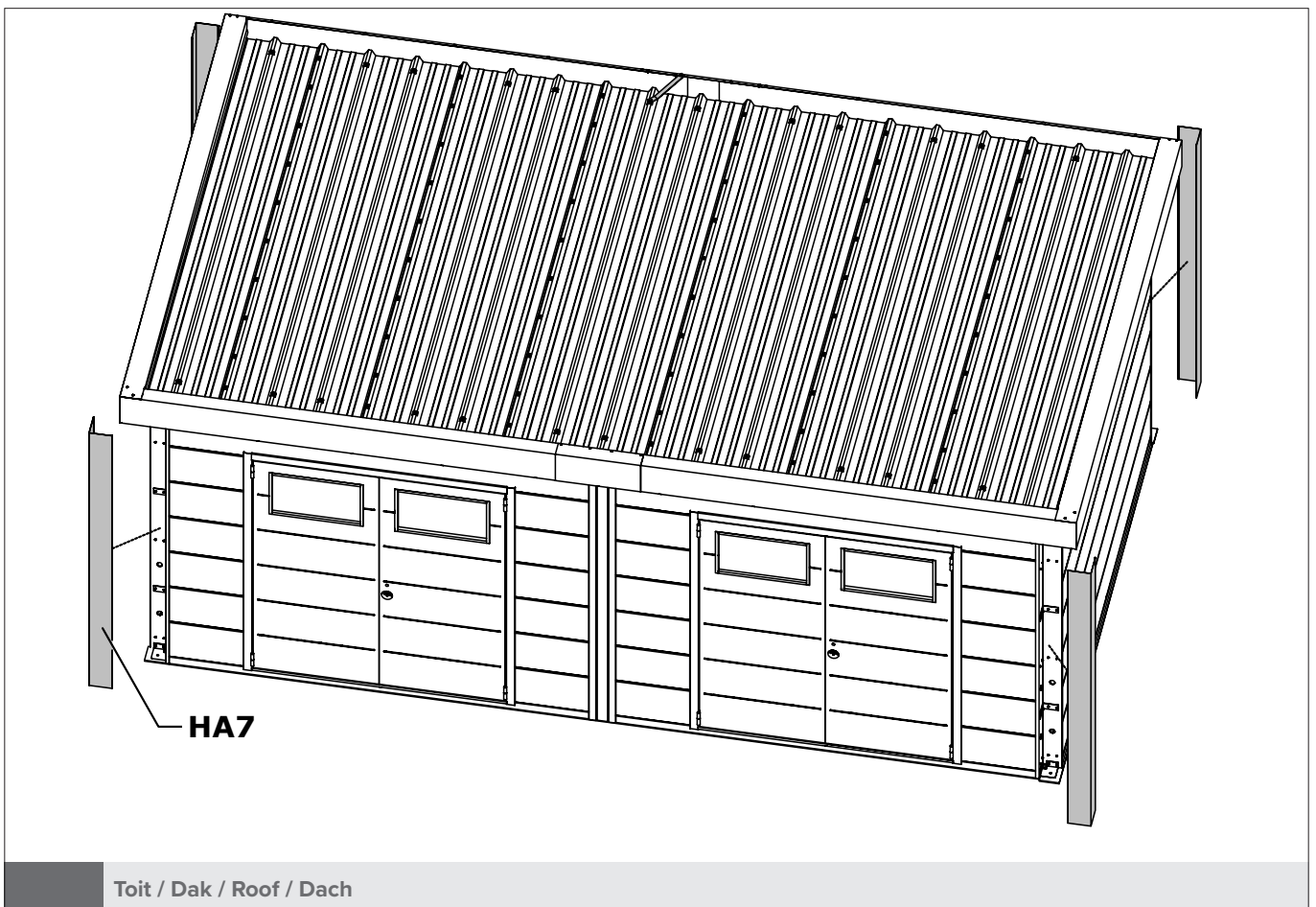
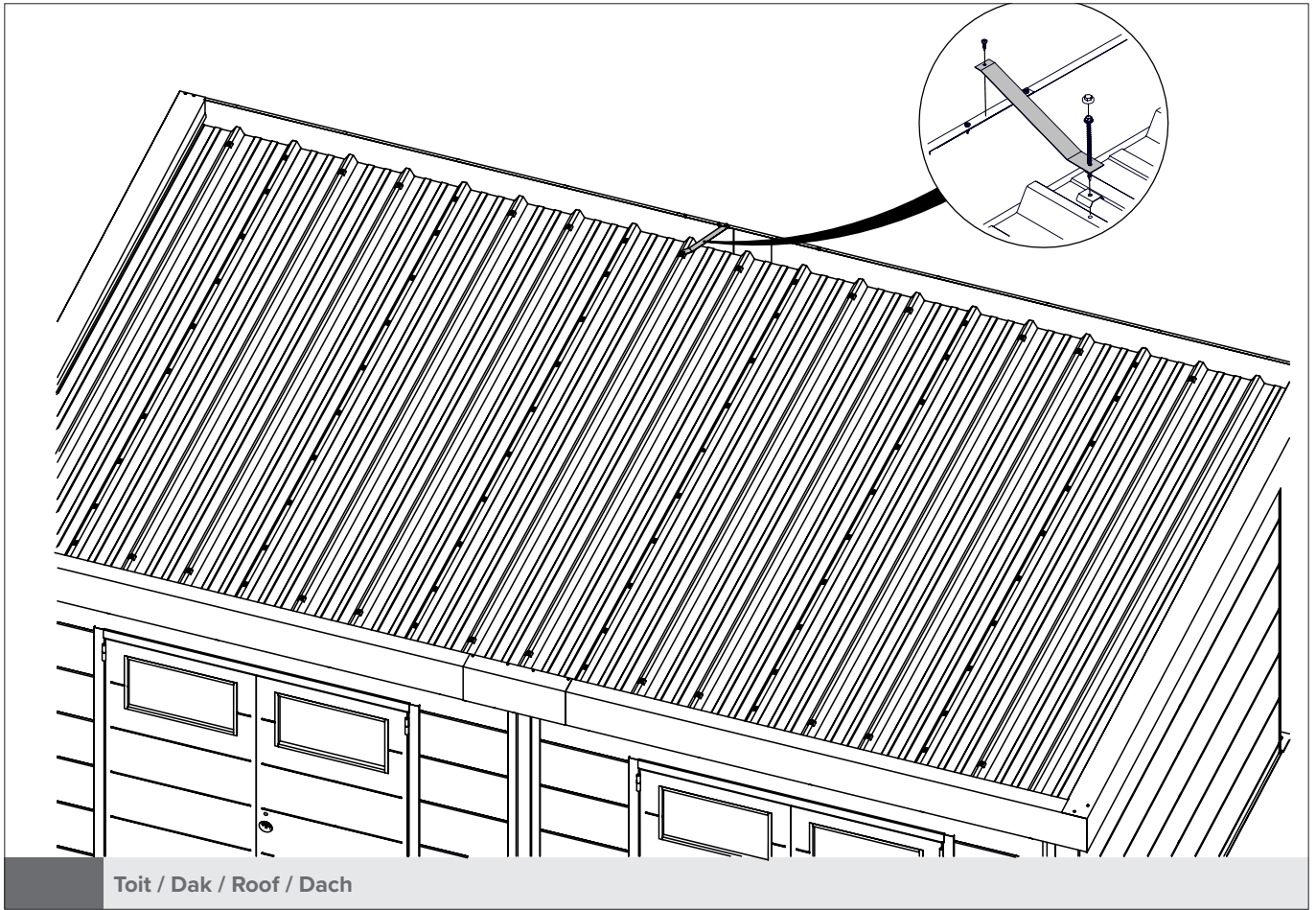

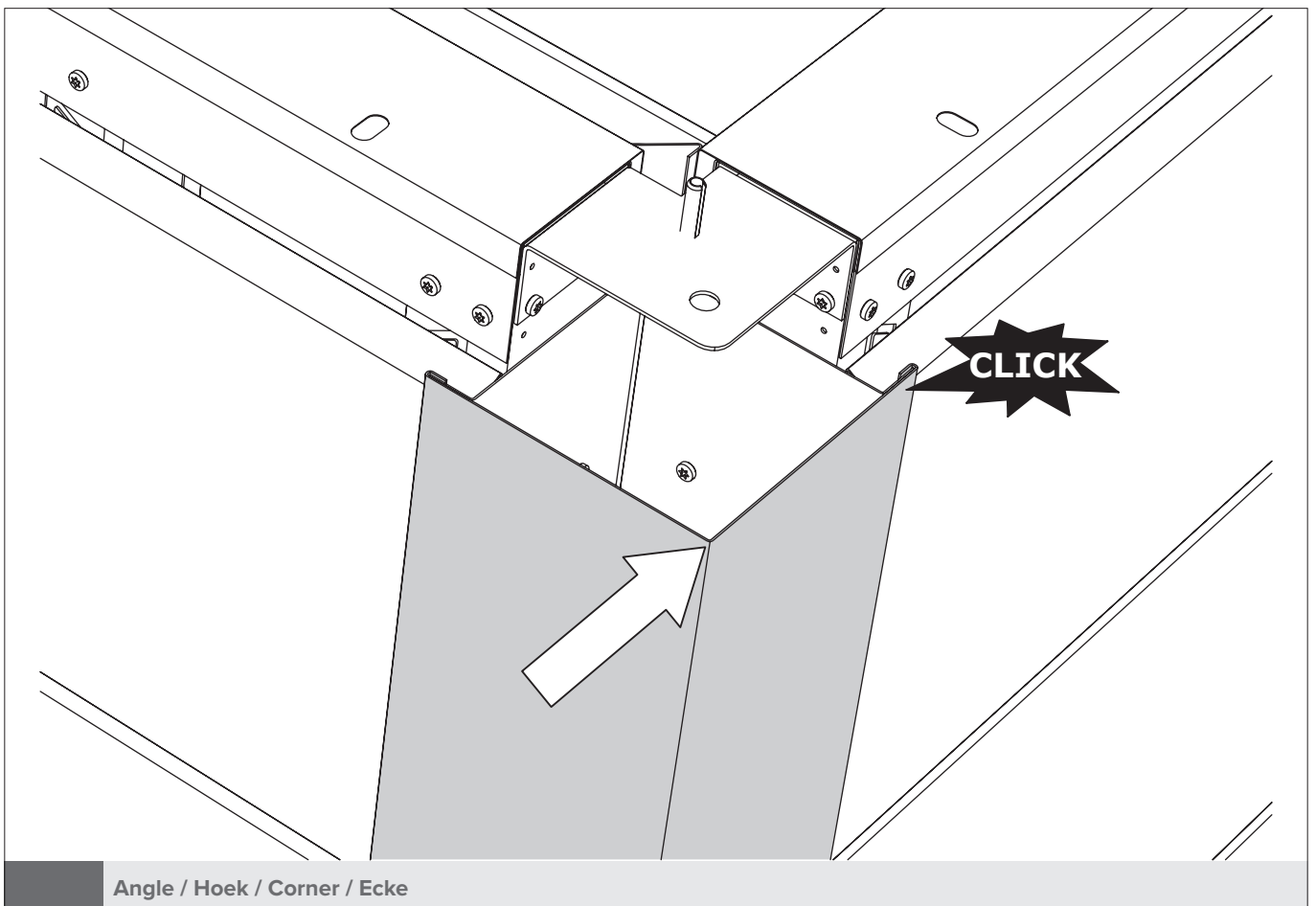
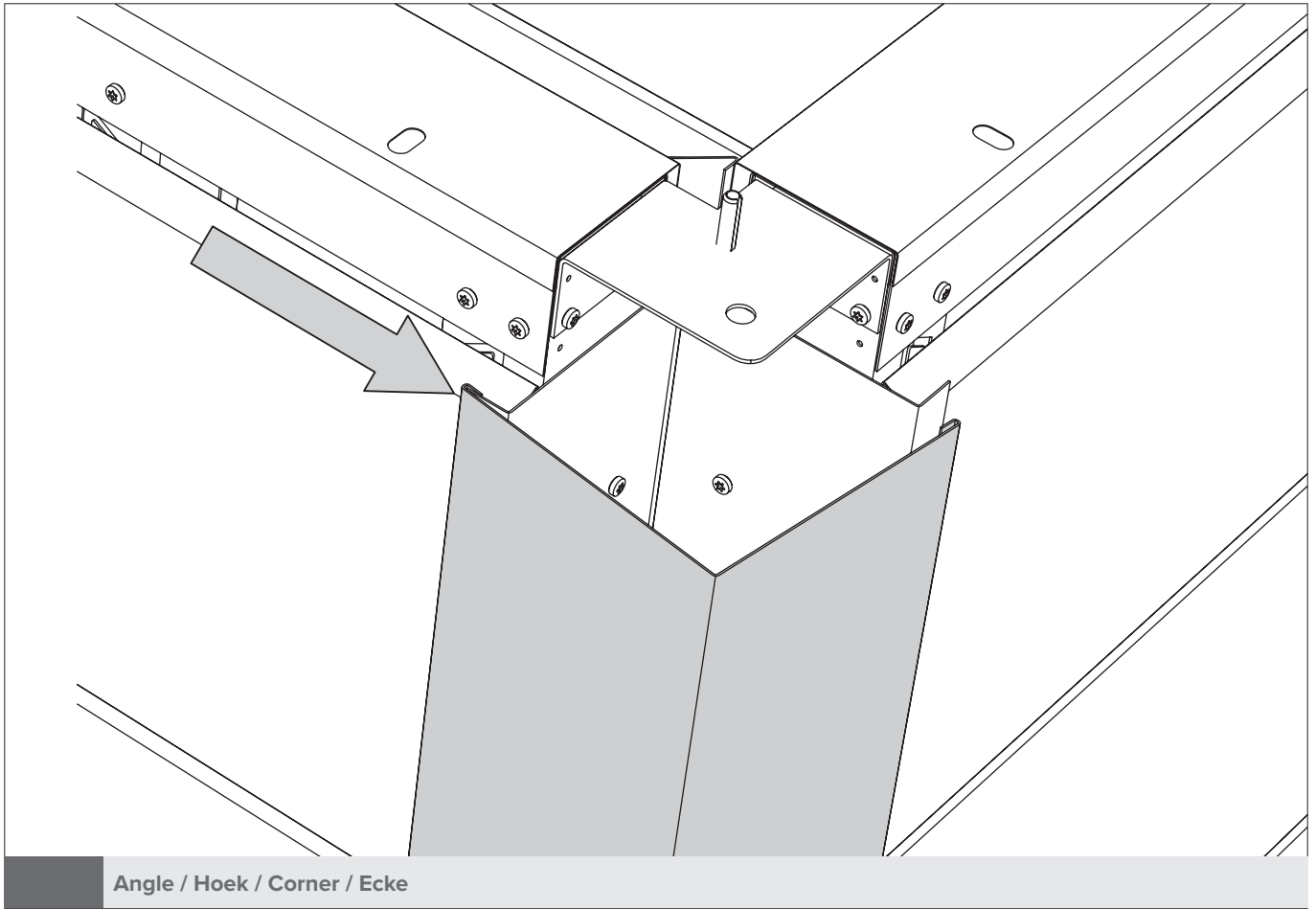

2X

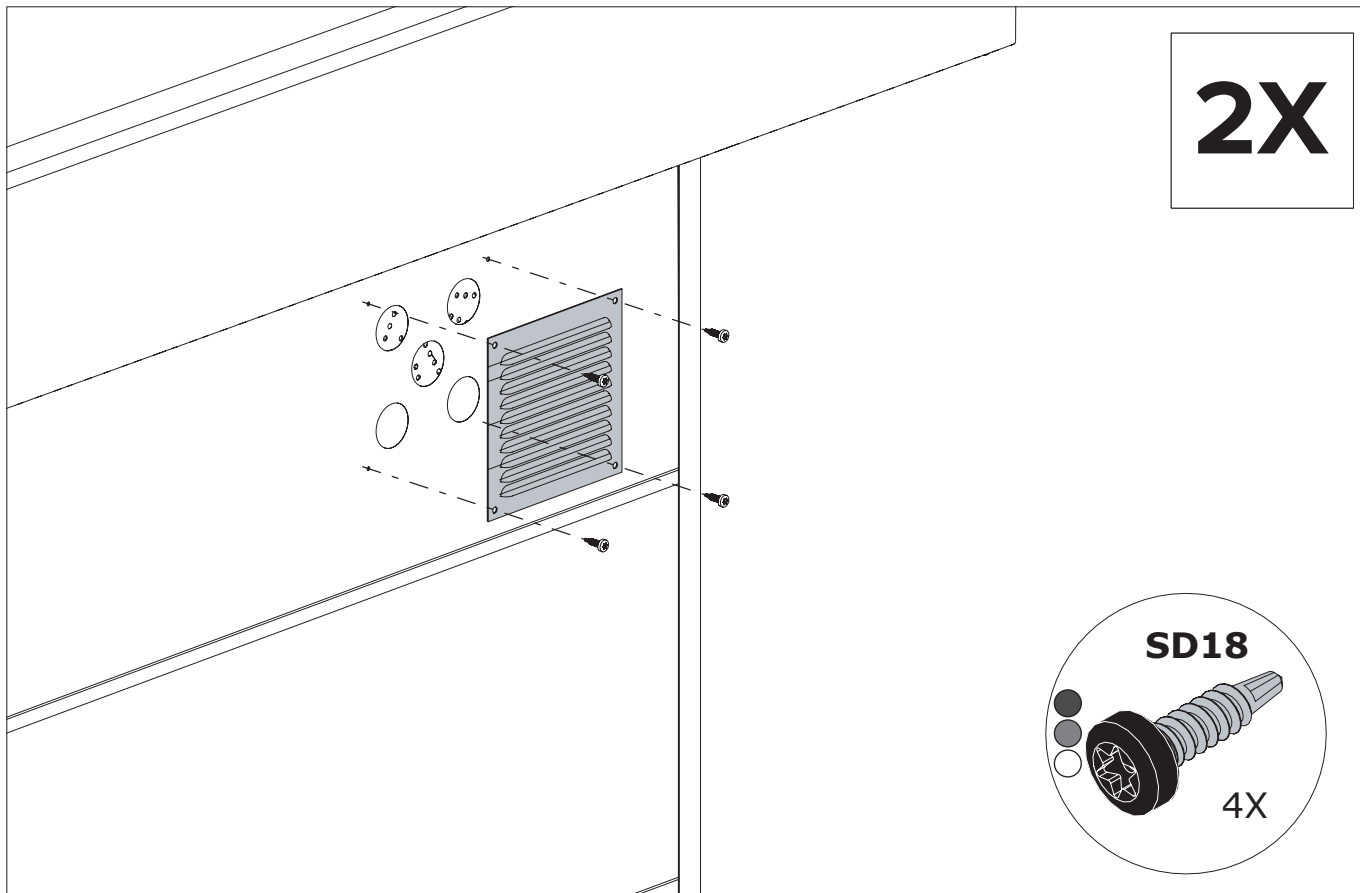

Toit / Dak / Roof / Dach

2X

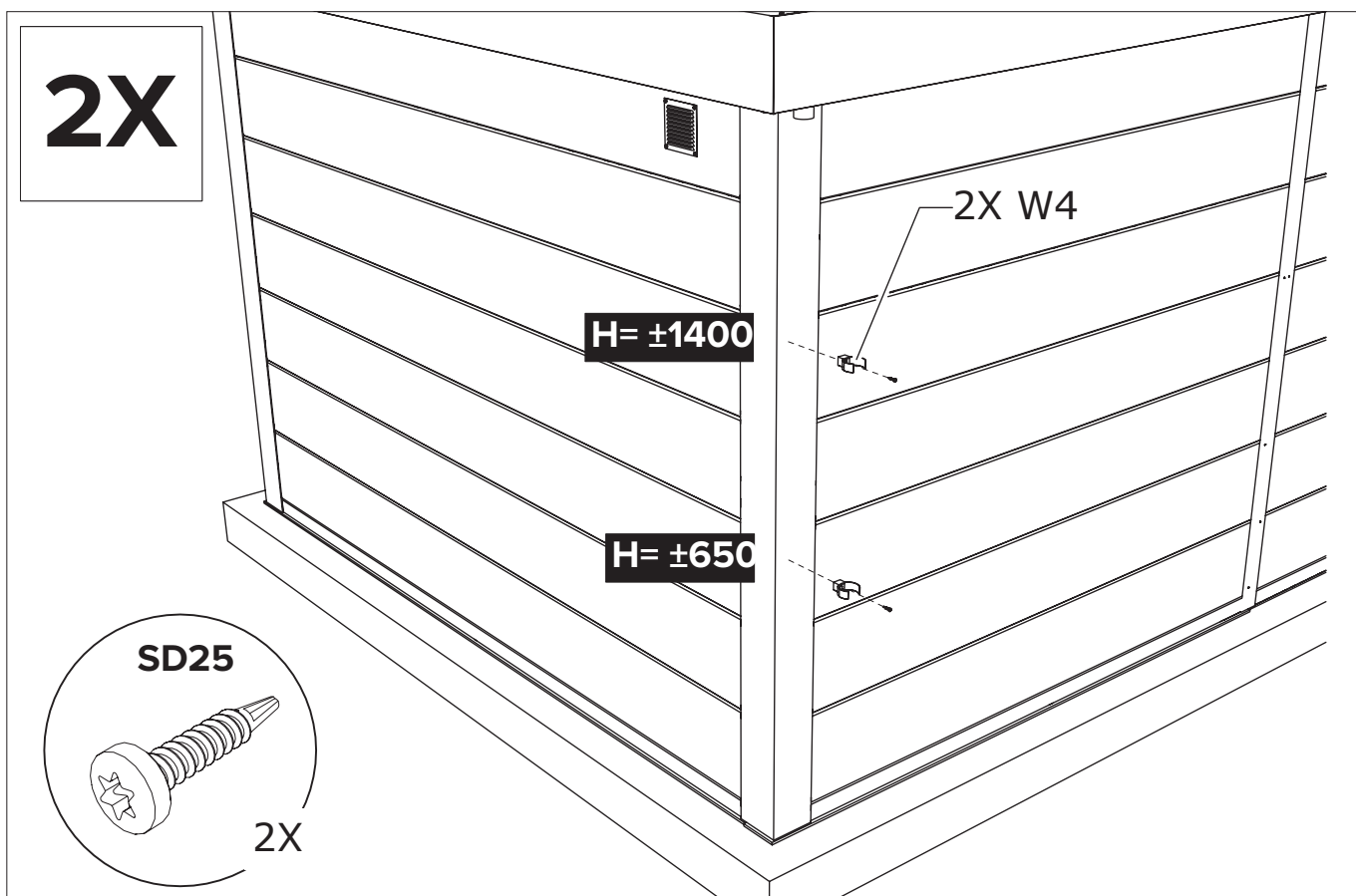

Angle / Hoek / Corner / Ecke

2X

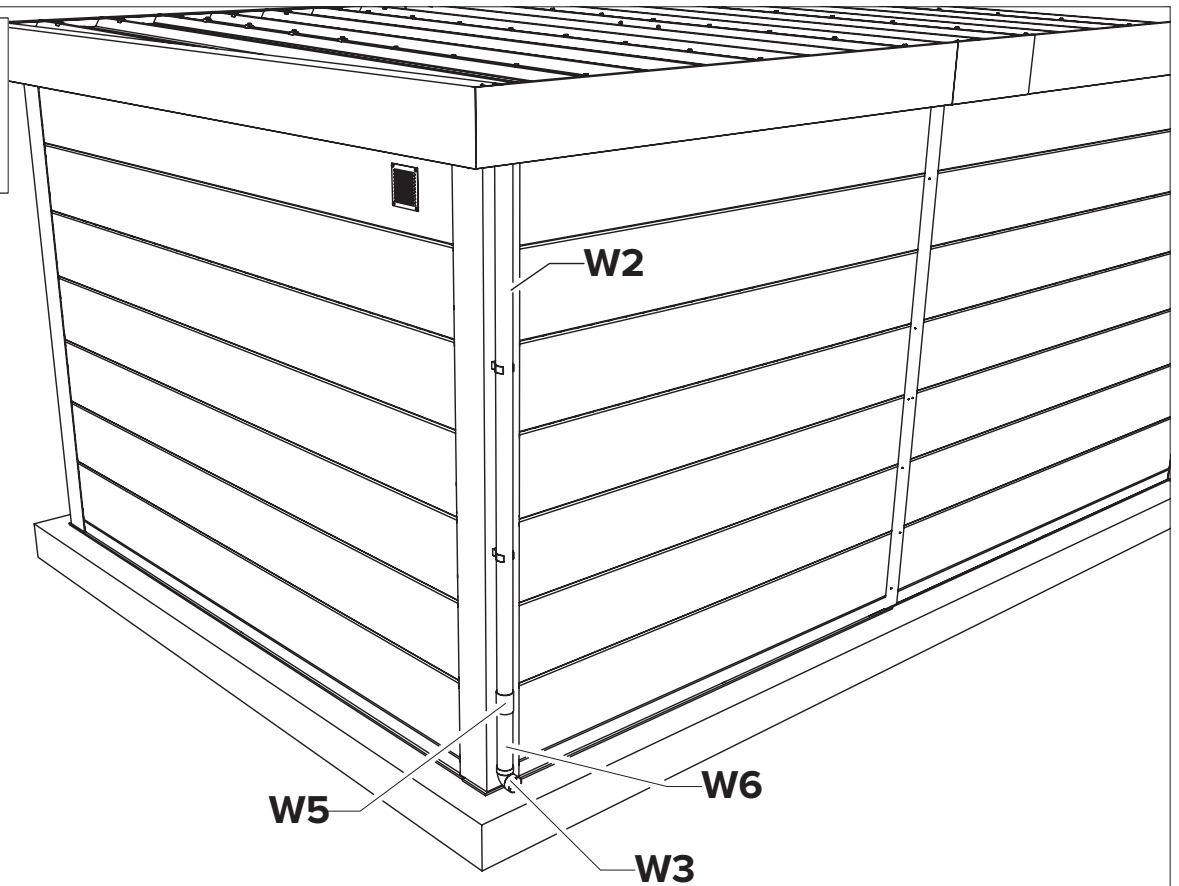

Drain / Afwatering / Drainage / Drainage

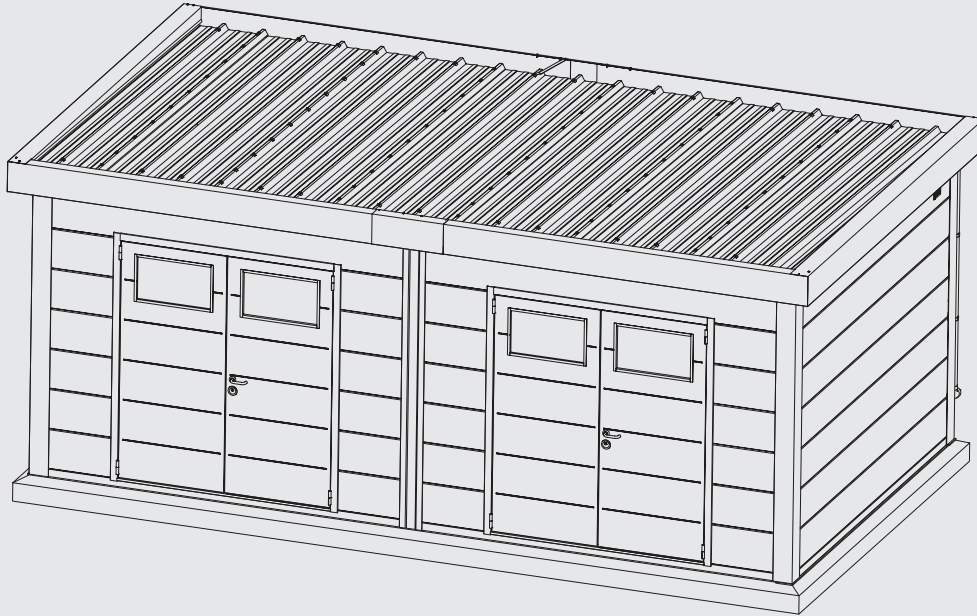

Merci de respecter l'environnement !

Pour une élimination correcte des déchets, il faut trier les différents matériaux conformément à la législation en vigueur. Droits d'auteur Telluria. Tous droits réservés. Aucun élément de la présente publication ne peut être reproduit ou diffusé sans l'autorisation écrite de Telluria. Les informations figurant dans la présente publication sont, pour des raisons techniques et/ou commerciales, sujettes à modification sans avis préalable. Telluria ne peut être tenue pour responsable des éventuels oublis et erreurs de la présente publication.

Draag zorg voor het milieu!

Voor een correcte afvalverwijdering moeten de verschillende materialen volgens de toepasselijke regelgeving worden gescheiden. Auteursrechten Telluria. Alle rechten voorbehouden. Niets in deze publicatie mag worden gereproduceerd of verdeeld zonder de schriftelijke toestemming van Telluria. De gegevens in deze publicatie zijn, omwille van technische en/of commerciële redenen, onderhevig aan wijziging zonder voorafgaande kennisgeving. Telluria is niet verantwoordelijk voor eventuele vergissingen of onjuistheden in deze publicatie.

Protect the environment!

To ensure waste is disposed of correctly, the different materials must be separated according to the applicable regulations. Copyright Telluria. All rights reserved. Nothing in this publication may be reproduced or distributed without written permission from Telluria. The information in this publication is subject to change for technical and/or commercial reasons at any time and without notice. Telluria is not responsible for any errors or inaccuracies in this publication.

Achten Sie auf die Umwelt!

Um eine ordnungsgemäße Entsorgung zu gewährleisten, müssen die verschiedenen Materialien entsprechend den geltenden Vorschriften getrennt werden. Copyright Telluria. Alle Rechte vorbehalten. Kein Teil dieser Publikation darf ohne schriftliche Genehmigung von Telluria vervielfältigt oder verbreitet werden. Aus technischen und/oder kommerziellen Gründen können sich die in dieser Publikation enthaltenen Informationen ohne vorherige Ankündigung ändern. Telluria ist nicht verantwortlich für Fehler oder Ungenauigkeiten in dieser Publikation.

VOUS AVEZ DES QUESTIONS SUR CE PRODUIT:

Vous trouverez plus d'informations dans le manuel d'utilisation.

Mail du service clientèle: eleganto-service@telluria.eu

HEEFT U VRAGEN OVER DIT PRODUCT:

Bekijk even de informatie in de service-handleiding.

Mailadres klantendienst: eleganto-service@telluria.eu

DO YOU HAVE QUESTIONS ABOUT THIS PRODUCT:

Please note the information mentioned in the service guide.

Customer Service Mail: eleganto-service@telluria.eu

SIE HABEN FRAGEN ZU DIESEM PRODUKT:

Bitte beachten Sie dazu die Informationen aus dem Serviceleitfaden.

Kundendienst-Mail: eleganto-service@telluria.eu